



MONARCH MACHINE TOOL COMPANY

OPERATOR'S MANUAL

for

MONARCH MODEL "EE" SENSITIVE PRECISION TOOL MAKERS' LATHE

IMPORTANT INFORMATION

To gain the greatest benefit from these instruction sheets it should be clearly understood that all the reference numbers throughout the text are related to illustrations. For example, the number A-4 refers to number 4 on figure A. The illustrations are grouped together to facilitate handling.

Where directions are given for operations, the necessary steps are listed as step 1, 2, 3, etc. Additional information, which may be desired, is placed in parenthesis, (), with each step.

We believe that questions may arise that are not covered in this booklet, and should further information be desired, a written request will be given our fullest attention. In such cases it will be helpful if the serial number of the machine, is included in the letter. This number is found on the name plate, on front of headstock, and it is also stamped on the front way of bed at the tailstock end.



MONARCH MACHINE TOOL COMPANY

Sidney, Ohio, U. S. A. • Area Code 513, 492-4111

CHECKING — CLEANING — INSTALLATION

The packing list, included in the box of parts, shows the contents of the shipment, and should be carefully checked. Any shortages or discrepancies should be reported immediately to the Monarch Machine Tool Company. Remember to mention the serial number of the lathe, which is found on the identification plate on the front of the machine.

The anti-rust slushing compound should be carefully cleaned off, and *before moving the tailstock or carriage*, a thin film of oil applied to the bed surfaces. However, before power operation, the machine should be oiled according to instruction under "Lubrication".

The machine should be placed in the desired position using the floor plan on Print E. E. 2140, to allow for working clearances.

Since the machine weighs 2,500 lbs., it should be mounted on a solid foundation to keep vibration at a minimum. The greatest accuracy of the machine will be obtained under this condition.

Take care that the lathe rests *only on the three pads shown* on the drawing—this three-point contact greatly helps to reduce the twisting stresses that may occur in the lathe bed through uneven seating on the floor. It is not necessary to have the lathe level lengthwise, but it is of utmost importance to have it level crosswise. Level the machine crosswise in front of the headstock and in front of the tailstock by placing one parallel on the front flat of the bed and another parallel on the rear flat and set an accurate machinist's level across the parallels. There is no need to fasten this lathe to the floor. If the machine ever should fail to turn or bore "straight" then the leveling should be rechecked.

CARE OF LATHE

Cleanliness The secret of care-free performance of the machine is *cleanliness and careful oiling*. All working parts exposed to chips, dirt or oil should be cleaned frequently. The oil should be drained from E-1, E-8 and D-9 once a year and the reservoirs flushed with kerosene to remove sludge or sediment.

Care of Apron Reservoirs supply the oil to the headstock and gear box—the apron is lubricated by a pump operated by the handwheel, G-4. When doing strictly facing work, for long periods at a time, it is good practice to run the carriage along the bed, at intervals, to insure proper lubrication of the entire carriage.

The clutch is tightened by turning G-6 clockwise.

Automatic lubrication relieves the operator of much oiling drudgery, but, oil levels should be constantly checked and the requirements of the Lubrication Chart carefully fulfilled.

SPECIFICATIONS: Oil—S. A. E. 10 and 20 or equivalent.

Oiling	Check Daily	Headstock bearings D-2 and D-5 Tailstock D-7 and D-8	S. A. E. 10 S. A. E. 20
	Check Weekly	Headstock D-4 Gear box E-2 and D-15	S. A. E. 20 S. A. E. 20
	Check 6 Months	V-S Drive (Use Special Grease)	See tags on unit
	Check Weekly	Gear Box on DC Motor E-5	S. A. E. 20

INSTRUCTIONS FOR THE RELIANCE V-S DRIVE

Description Within the base of the lathe is mounted the Reliance V-S Drive. This is an electric Drive consisting of an AC motor, a DC generator, an exciter and a DC motor with the necessary control panel. The AC motor and DC generator are combined into one unit called the Control Unit. The DC motor is supplied with power from this control unit. The control consists of a speed setting rheostat and a control panel. The exciter is mounted on top of generator and driven by belt E-19.

Connection of V-S Unit The V-S Drive is connected to the outside AC power supply at F-5. Make sure that the correct AC voltage and frequency is applied. The proper voltage and frequency is indicated on tag at F-5. CAUTION: Remove Cover D-14 and make certain that armature of control unit rotates in the direction of rotation plate. If armature rotates in wrong direction, change any two wires at F-5.

Operation The control unit is started by the push-button D-11 at the beginning of each work period and is shut down when the work is done. When the control unit is running, the "start" push-button should be lighted up. This does not start the motor. The motor is started and stopped in either the forward or reverse direction by the hand lever A-15. This hand lever must be in the center or "off" position in order to start the control unit. The speed is controlled by the knob E-7. The speed may be adjusted while the spindle is turning or at rest.

Back Gear To give higher torque for spindle speeds under 400 RPM, the back gear unit can be engaged by the lever E-9; however, this change should not be made unless the spindle is stopped. Lever E-9 must be in open belt or back gear position for DC motor to turn spindle.

Overload Protection A sustained overload on either the motor or the control unit will cause the spindle to be stopped automatically. If either unit stops because of overload, wait a few minutes for the overload relay to cool, then press the re-set button at F-6 and E-12.

Care of the V-S Drive The life of the electrical equipment is increased in proportion to the care it receives. Make careful, regular inspection at least once each week, giving special attention to the following points:

The generator, motor and exciter are Direct Current machines and are equipped with commutators and brushes. For satisfactory operation, the brushes must slide freely in the brush-holders and must rest securely against the commutator at all times. Check belt (E-19) for any slippage. Brushes are expected to wear and must be replaced, and since the exciter is the smallest unit, its brushes will have to be replaced first. More than 1500 hours of service should not be expected from these brushes. Replacement brushes should be kept available.

Brushes

In replacing brushes after placing the new brushes in the holder, carefully fit the rubbing or contact surface of the brush to the curvature of the commutator by fitting a strip of sandpaper to the commutator and placing the brush in the holder so that it contacts the abrasive side of the sandpaper, then sanding the brush to fit the curvature of the commutator. The sandpaper used should be first a No. 1 paper and then a finer grade such as No. 00. An extra set of brushes are included with instructions.

Com-mutator

The commutators should be kept clean, and it will gradually assume a dark polished surface. As long as these conditions exist, the commutators should not be touched, but in case of burning, as indicated by a dull blackened appearance on the surface, the commutators may be dressed by No. 0000 sandpaper or a fine commutator stone. Do not under any condition use emery or carborundum cloth or paper.

Dirt, grease, oil or water must be kept off from the electrical parts, especially the commutators. If any is found to be collecting, it should be wiped off and steps taken to prevent any accumulation.

Lubri-cation

The ball bearings on the control unit and motor are packed with Lubriko M-32 grease at the factory. Grease should be added twice yearly at the five Keystone fittings. The grease should extrude $\frac{1}{8}$ " from the release holes which are visible on the fittings; except at rear end of exciter and D. C. motor. These points should be checked by using a mirror and flashlight. Use only a neutral grease.

Control

Condition of the contactors should be checked once a month for excessive wear and burning. See control panel E-6.

Service Hints

In case of failure of the spindles to turn when starting lever A-15 is thrown in the forward or reverse direction, first make sure that the lever E-9 is engaged fully either in the back gear or in the direct drive and that the motor itself is not running. Second, make sure that the control unit is rotating. Third, check with the voltmeter or test lamp for loss of exciter voltage. This can be done by checking voltage across the exciter brushes, see item 34, Parts Picture R-2. If no voltage is present, the trouble may be due to a dirty commutator or a brush not making good contacts with the commutator. Examine the brushes to make sure the brush-holder springs are causing the brushes to bear firmly against the commutator. Install new brushes if brushes are worn down. Clean the commutator with sandpaper and press the brushes firmly against the commutator with wooden sticks. If this does not produce the desired results and produce voltage across the exciter brushes, contact the manufacturer.

If exciter voltage is present, and still the motor will not turn when lever A-15 is operated, have competent electrician check wiring with diagram on back of cover of control box, E-6.

If after reasonable amount of investigation the unit cannot be made to operate, contact the manufacturer, giving all possible information including the results obtained by following the above instructions.

NOTE: When ordering repair parts be sure and give the serial number of the motor and the control unit.

GENERAL DESCRIPTION

The spindle is a direct drive type and has no gear arrangements for speed changes.

Pulley A-1 is keyed to the spindle and driven from the electrical unit; also keyed to the spindle are: A-12, A-2 and A-3 (it should be noted that A-3 gives a constant drive through A-8 to the tachometer A-7).

When knob A-4 is in feed index position (neutral) all additional gears in the headstock are idle.

When knob A-4 is in "forward" position the clutch A-2 engages the following gears: A-6 to A-10 to A-18. This connects the end-gear train in gear box for right-hand threading.

Headstock Mechanism

NOTE: Gears A-5 and A-6 are supported independently of the spindle.

When A-4 is in "reverse" position—the drive is through A-2 to A-5 to A-17 to A-9 to A-18, which gives the left-hand direction to the leadscrew.

A-12—This gear locks the spindle for changing chucks, etc.

A-11—This is an oil-slinger for tachometer drive gearing.

A-14—Is the lock-nut for spindle bearing adjustment.

A-13—Is the gear-guard release knob.

E-9A—is a gear box with a 6 to 1 ratio. This provides the same mechanical advantage as back gears for machining at low speeds. Knob E-9 engages the gears as desired.

- A web belt from the spindle to pulley B-4, operates the feed mechanism in the gear box. The stages of the feed mechanism are as follows:
- Gear Box Mechanism** Gear B-18 drives clutch gear B-5 to tumbler shaft gear B-8, then to B-14, to cone-gear shaft B-9 and clutch gear B-10.
- On the other end of the cone-gear shaft B-10, is a gear which drives the feed shaft B-13. *This gives the feed range, from .0012" to .0075", designated on the lower half of the index plate.*
- Apron** The apron handwheel G-4 may be connected or disconnected by clutch G-3. The cross-feed and longitudinal-feed friction levers, G-5 and G-10, engage the feed when pushed down. Pushing in or pulling out knob G-11 reverses the direction of the feed. Pushing down G-12 engages the half-nuts with the leadscrew for threading operations. The apron is equipped with an interlocking assembly, which makes it impossible to engage the half-nuts and longitudinal feed at the same time.

STEPS IN OPERATION—FEEDS

The range of feeds are indicated on the lower half of the index plate. The gear box is operated by the control knobs B-1 and B-2, and the selector handle B-3.

Steps

- Method of Selecting Feeds**
1. Set control knob, B-2, to feed position. (This operates through B-5 and B-6 to engage the feed through clutch on B-5; during feed operations the end-gear train is idle).
 2. Turn control knob, B-1, to the A. B. C. range on which the desired feed is listed. (This knob activates B-10).
 3. Push in the selector handle, B-3, to disengage the idler gear B-14, through a cam plate, not shown on illustration.
 4. Turn the pointer to the desired feed on the plate. (This operates through B-15, B-16 and B-17 to give the selected feed on the cone gear).
 5. Pull out the handle, B-3, to lock the gear engagement.

Steps

THREADS

- Method of Selecting Threads**
1. Select proper spindle speed.
 2. Move knob A-4 for right or left-hand thread.
 3. Set control knob, B-2, to thread position. (This disengages feed drive B-5, B-18, and engages B-7 through idler gears to A-18. The stages of the thread gear mechanism is as follows: B-7 to B-8 to B-14 to B-9 to B-10 to B-11 then to leadscrew B-12).
 4. Turn control knob, B-1, to the A. B. C. range on the upper half of the index plate on which the desired thread is listed.
 5. Push in the selector handle, B-3, and turn the pointer to the thread on the plate. (Note the essential stud and box gear information on the index plate—this simply means interchanging A-18 and B-7 as required).
 6. Pull out the handle, B-3, to lock the thread gear engagement.
 7. When using the thread chasing dial, G-14, the following rules should be observed: On any thread, where the lead is equally divisible by 8, the half-nuts may be engaged at any point without using the chasing dial. For all other whole threads, the half-nuts may be engaged at any of the four graduations on the chasing dial. For half threads, engage the half-nuts at opposite graduations, for example, No. 1 and No. 3, or No. 2 and No. 4. For quarter threads, the half-nuts must be engaged at the same graduation each time. For other fractional threads the use of the dial is not recommended.

Using the Thread Chasing Dial

Chasing Stop

G-9 is set by screwing "in" the knurled knob—this provides a positive stop and limits the revolutions of the cross-feed screw to two and one-half turns.

Supplementary Controls

G-1 are direct reading dials which read directly on diameter.

F-6 is a re-set button—this is a safety feature, should the switch be automatically thrown "out" then it is necessary to press this button to start the machine. If the lathe is equipped with a coolant pump, the pump switch is mounted to the right of F-6.

ADJUSTMENTS

- Carriage Clamps** There are four anti-friction hold down clamps on the carriage. To adjust—loosen the locking collar, G-15, and turn the eccentric stud, G-16, then tighten the locking collar. Avoid making the bearing too tight as it may cause excessive wear on the surfaces.
- Top Block** The top block gib is adjusted from one end only at G-7. The cross-slide is adjusted by two screws, G-8 screw in front and another rear screw located under the dust plate.
- Cross Slide** The lathe is equipped with a compensating cross feed screw nut. Adjustments should be made by removing the nut and reducing the shim.
- Half Nuts** The leadscrew half-nuts, G-12, may be adjusted by the two nuts located at rear of the half-nuts.
- Spindle Drive** The belts, running from the variable speed drive unit to the headstock spindle, are adjusted by the idler pulley, E-3. This pulley is mounted on a stud which slides in a tee slotted bracket.
- Tailstock** Lever F-2 is adjusted by nut underneath tailstock.

Instructions for Operating the Anti-Friction Bearing Taper Attachment

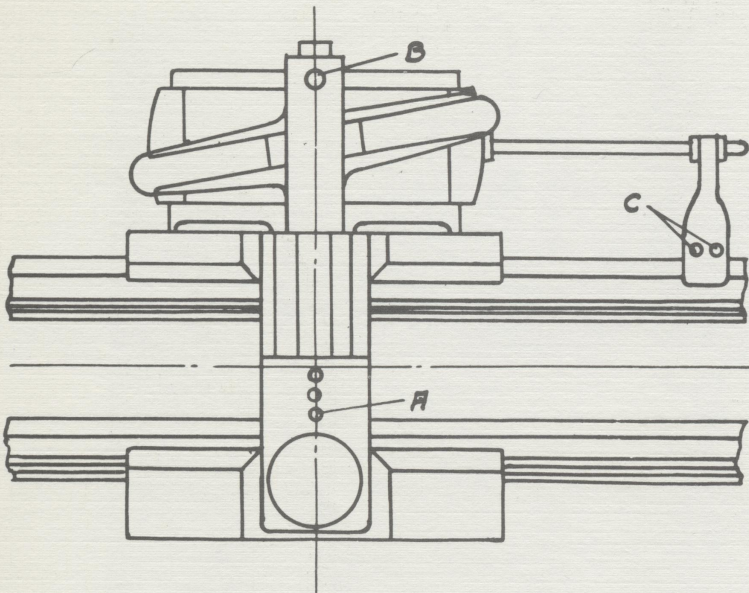

1. To turn taper, lock "A", loosen "B", lock clamp "C".
2. To turn straight loosen "A", lock "B", loosen "C".
3. Caution: Always lock "B" when straight turning.

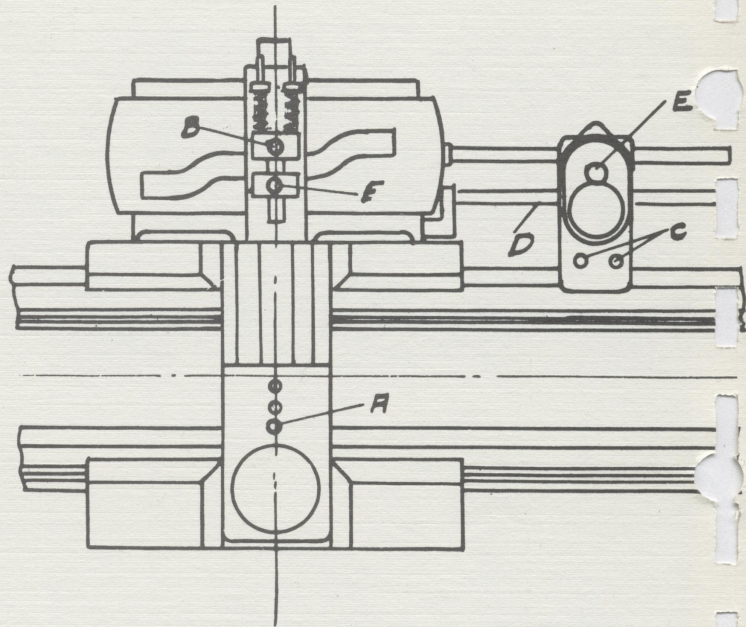

For Form Turning
 Loosen upper F
 Tighten upper B
 Tighten lower F
 Loosen lower B

For Form Boring
 Tighten upper F
 Loosen upper B
 Loosen lower F
 Tighten lower B

Form turning or boring with "Variator"

1. Tighten "A".
2. Use rack positions and gear positions shown when the template is to be longer than the work.
3. Where the template is shorter than the work, the position of the inside rack must be reversed and the gear positions the Variator must also be reversed from that shown in drawing.

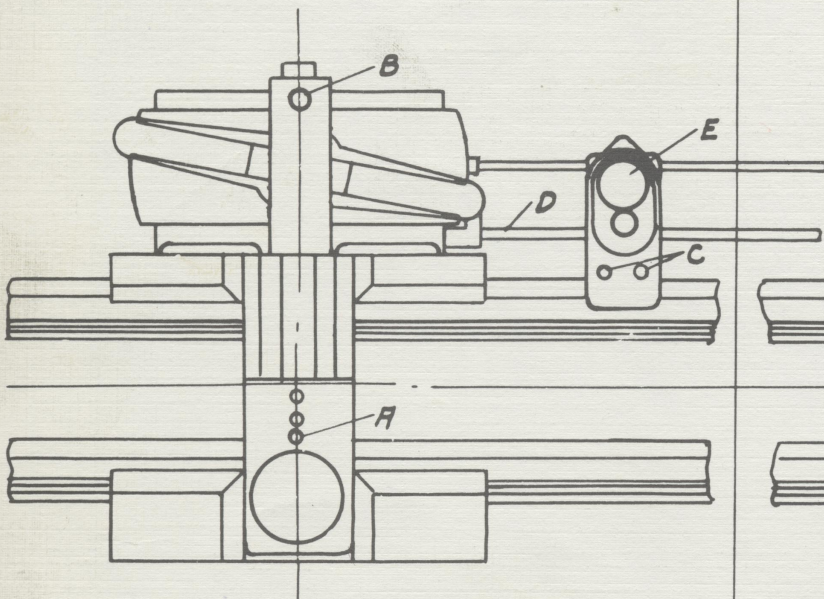

Long length turning with "Variator"

1. Tighten "A", loosen "B", use rack and gear positions as shown.

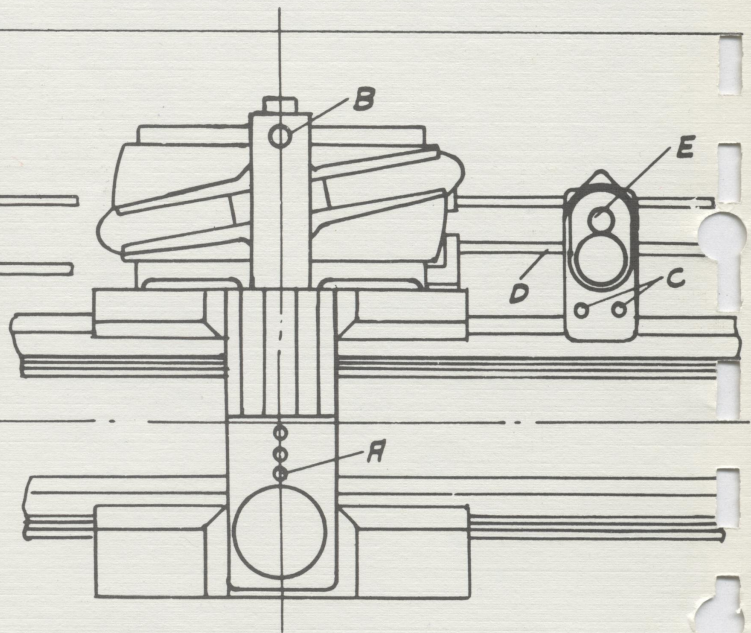

Steep angle turning with "Variator"

1. Tighten "A", loosen "B", use rack and gear positions as shown.

Service Instructions

For systems with lubricator type "G—"

BIJUR

automatic lubricating system

Your machine is protected by a built-in Bijur central lubricating system —by CORRECT lubrication of all bearings served, it assures smooth operation of your machine for years, if properly maintained.

The Bijur system consists of three basic elements: (1) a **lubricator** (pump) which periodically forces a measured volume of oil into (2) a single **line of distribution tubing** branched to supply oil to the bearing surfaces through (3) **Meter-Units** which proportion the correct oil film to each bearing.

OIL: Use only non-compounded clean mineral oil of type and viscosity recommended by machine manufacturer.

OPERATION: This fully automatic lubricating system is pre-set by the machine manufacturer for best operation. Lubricator Type G is a piston pump mounted in a reservoir or sump in the machine, and actuated by a moving machine element. Oil volume is determined by the original pump setting and is not adjustable; discharge frequency is determined by operation of the machine.

STARTING A NEW MACHINE: Fill reservoir with oil recommended by manufacturer.

MAINTENANCE: Check oil level daily and refill reservoir when required. **Replace filter assembly annually.** Check system periodically for loose or broken tubing, worn hoses, loose fittings and connections.

SERVICE: Too little oil at all bearings—check for low oil level, broken or cracked tubes, loose connections, flattened lubricator outlet-tube, or clogged filter. For **too little or too much oil at one bearing** see other side.

SERVICE PARTS: Order by **Part Number** and **Name** shown below—if provided with **Name Plate***, also specify lubricator **Type** symbol and **Serial** letters. Example: "S-109 Filter Assembly for Lubricator Type GBF Ser. LF." For major repairs requiring parts not numbered below, return lubricator for factory rebuilding and adjustment. If a new lubricator is required for replacement, order by **Type** symbol and **Serial** letters if provided with **Name Plate***; if **Name Plate** is not provided, return lubricator and specify type of machine on which used. Prompt shipment can be made on parts and lubricators.

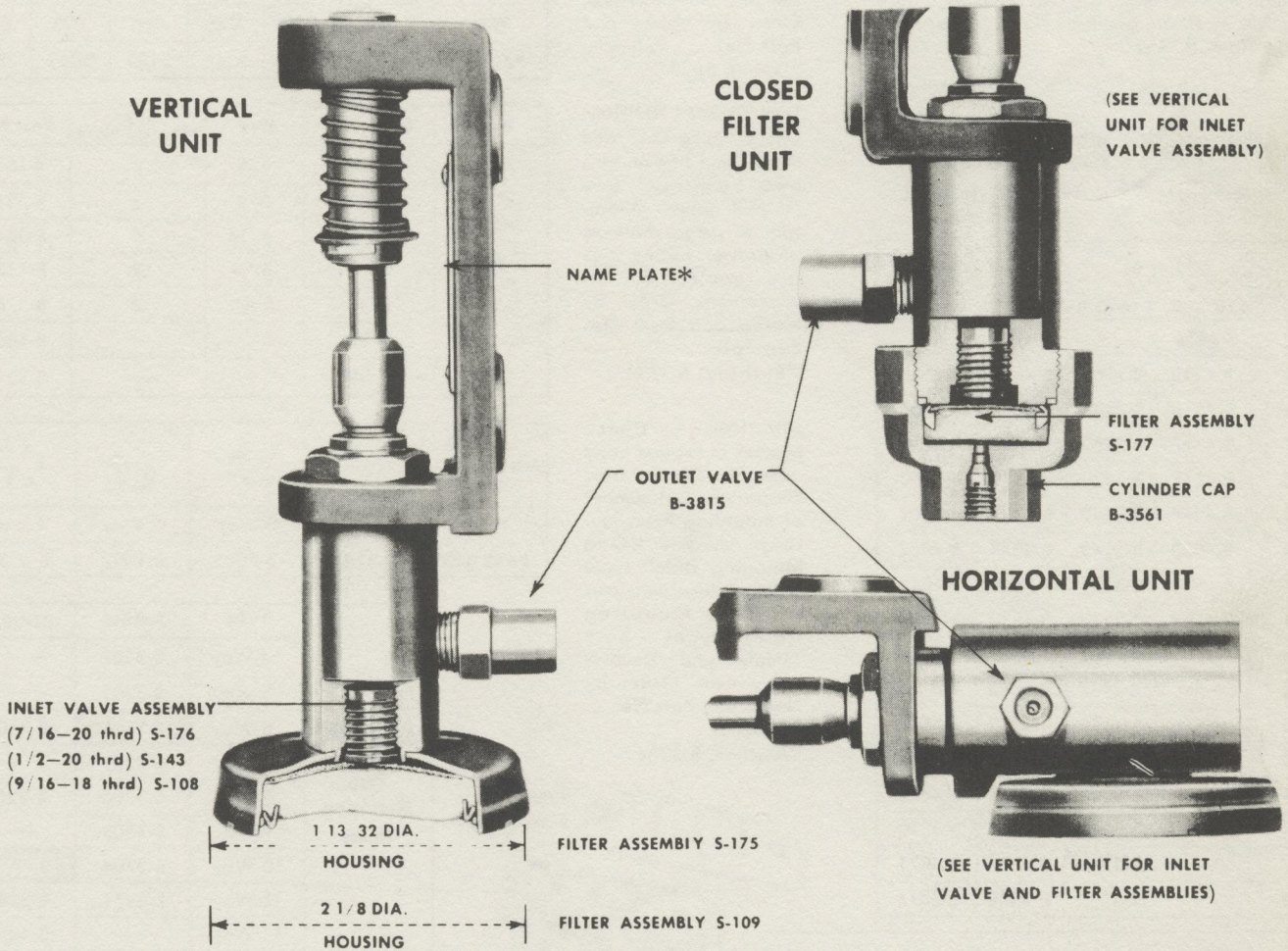

IMPORTANT: REPLACE FILTER ASSEMBLY ONCE A YEAR

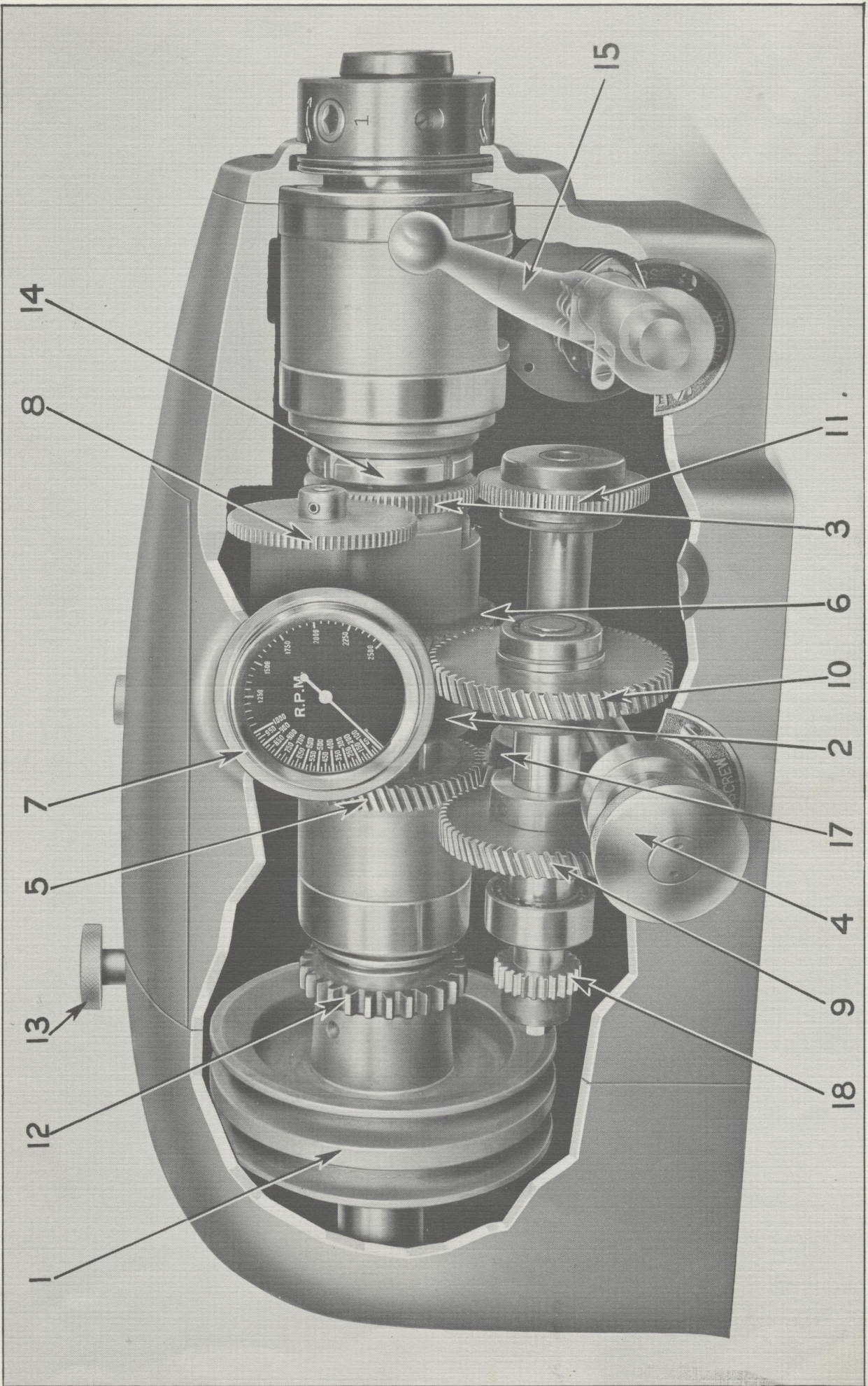

Figure A

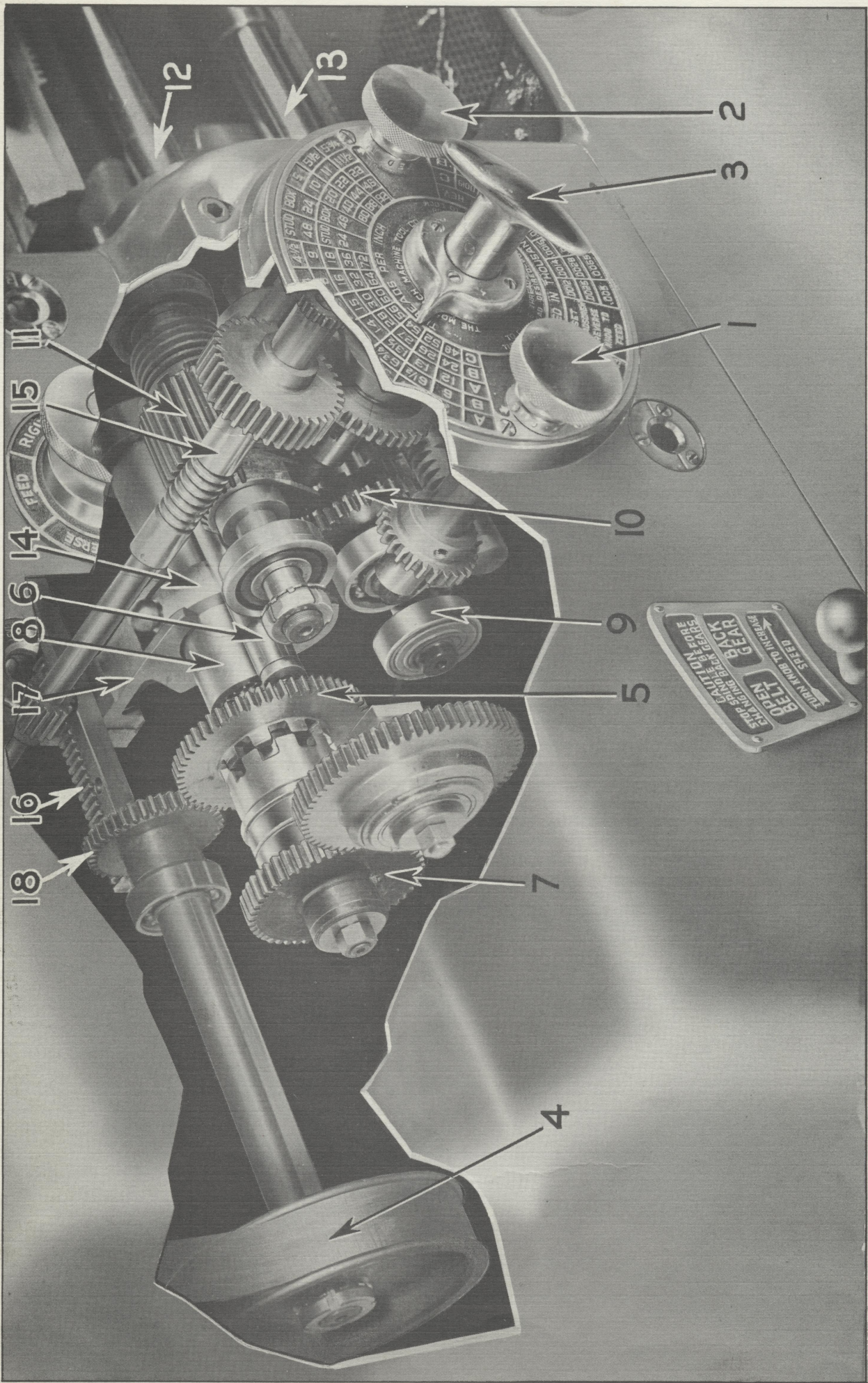
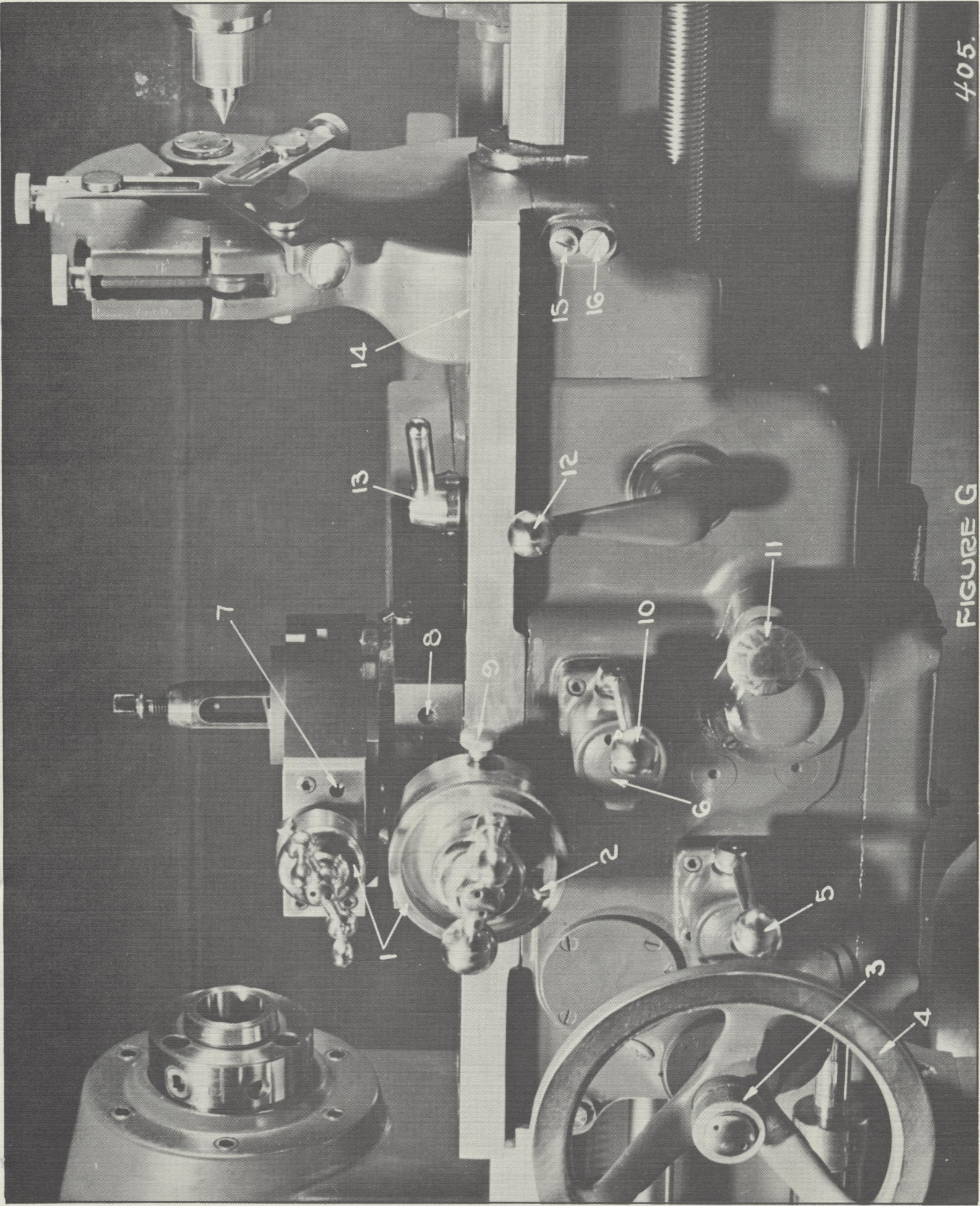

Figure B



405.

FIGURE G

Figure G

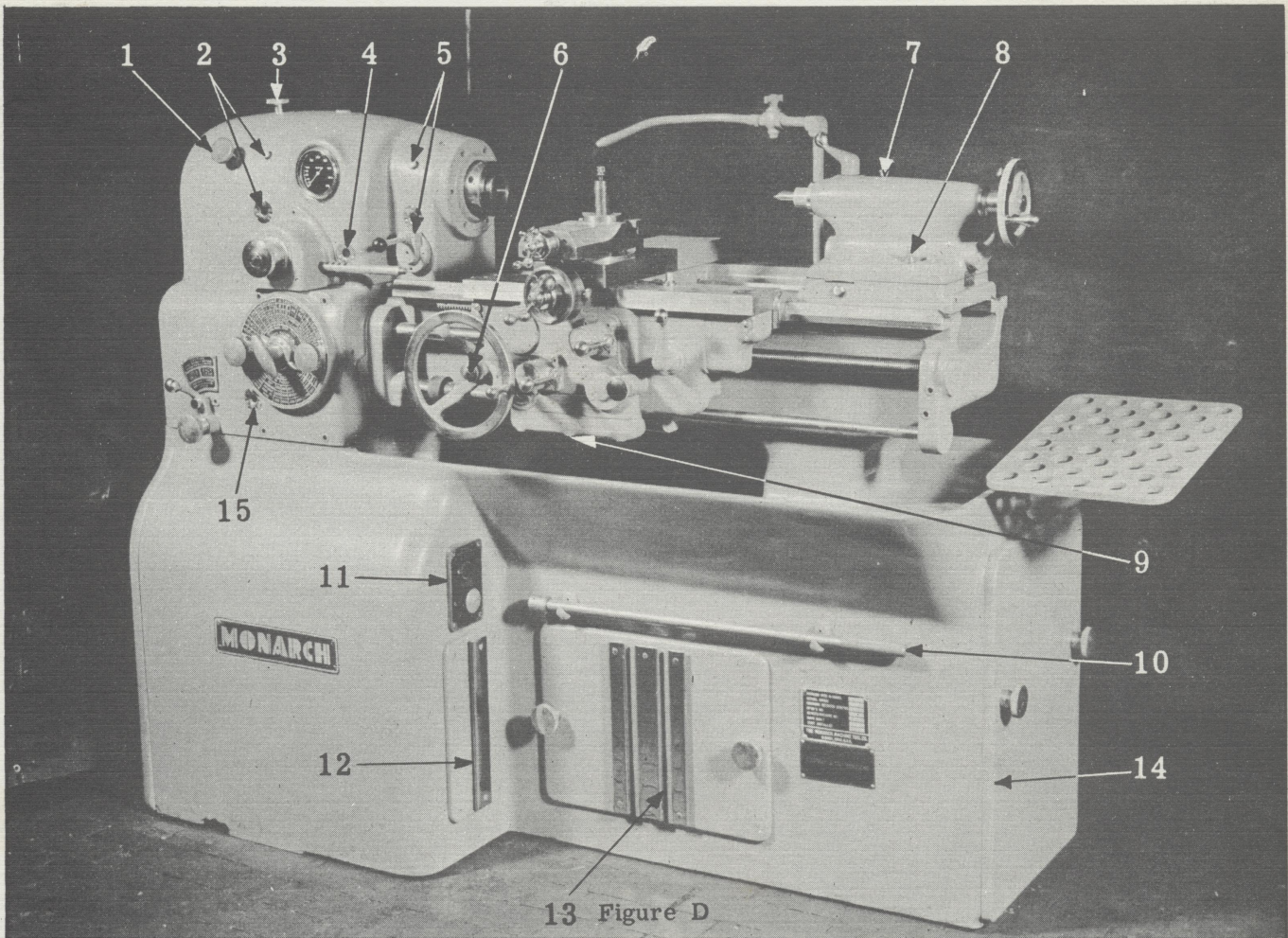

13 Figure D

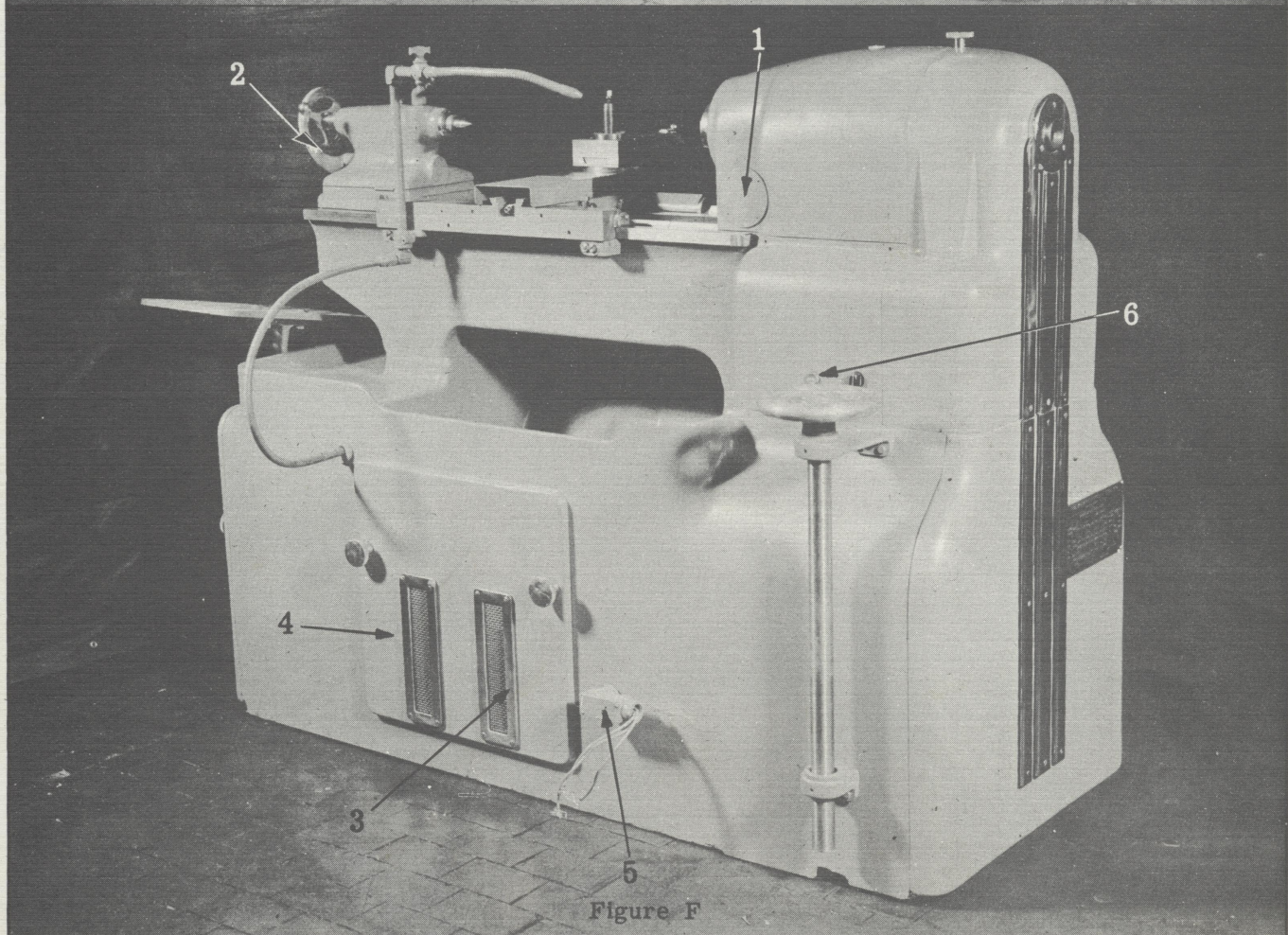
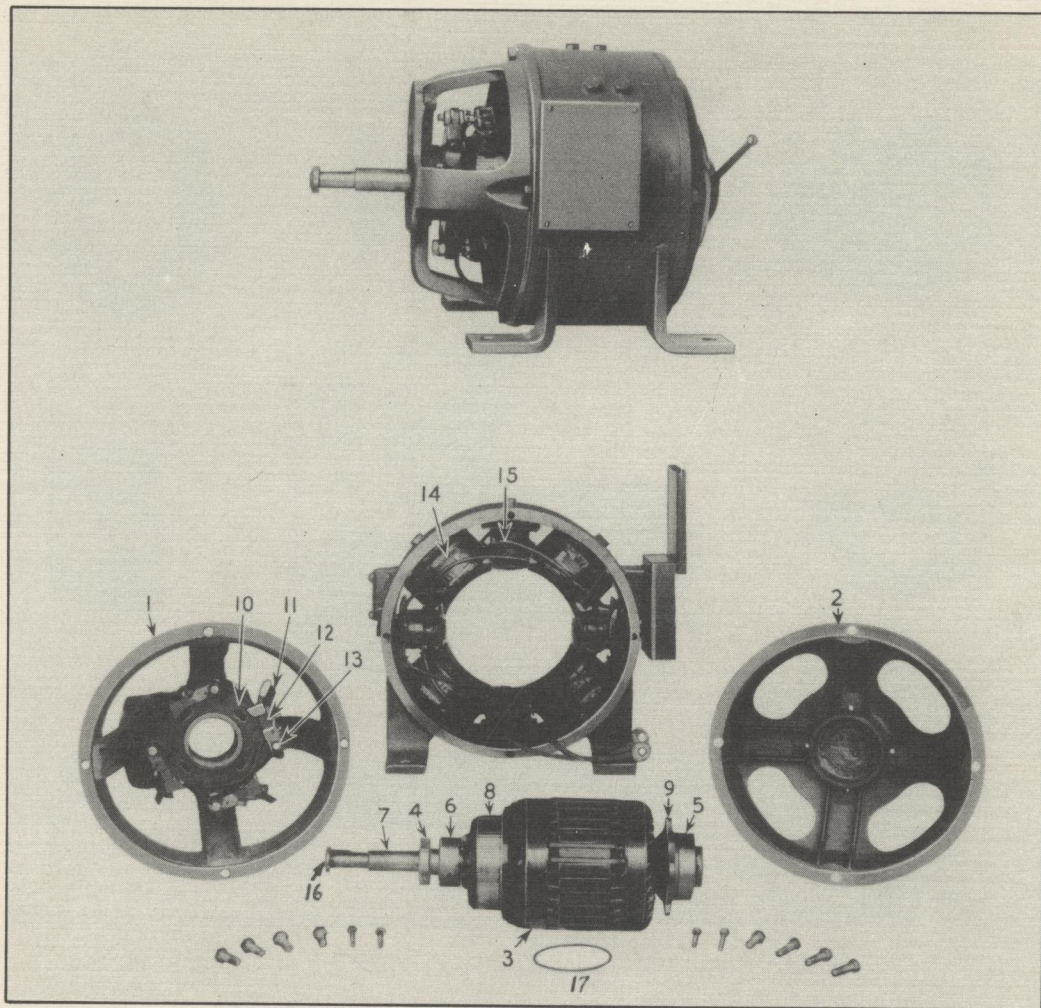

Figure F



MOTOR SPARE PART LIST

- | | |
|--|-------------------------------------|
| 1. Commutator End Bracket | 9. Back End Inner Cap |
| 2. Back End Bracket | 10. Rocker |
| 3. Armature complete with shaft, commutator, and winding | 11. Brush - 4 |
| 4. Commutator End Bearing | 12. Brushholder |
| 5. Back End Bearing | 13. Brush Stud |
| 6. Oil Seal | 14. Main Field Coil |
| 7. Shaft | 15. Intercoil |
| 8. Commutator | 16. Motor Shaft Lock-nut and Washer |
| | 17. Back End Inner Cap Gasket |

MONARCH LATHES

COVER THE TURNING FIELD

SIDNEY... OHIO, U.S.A.

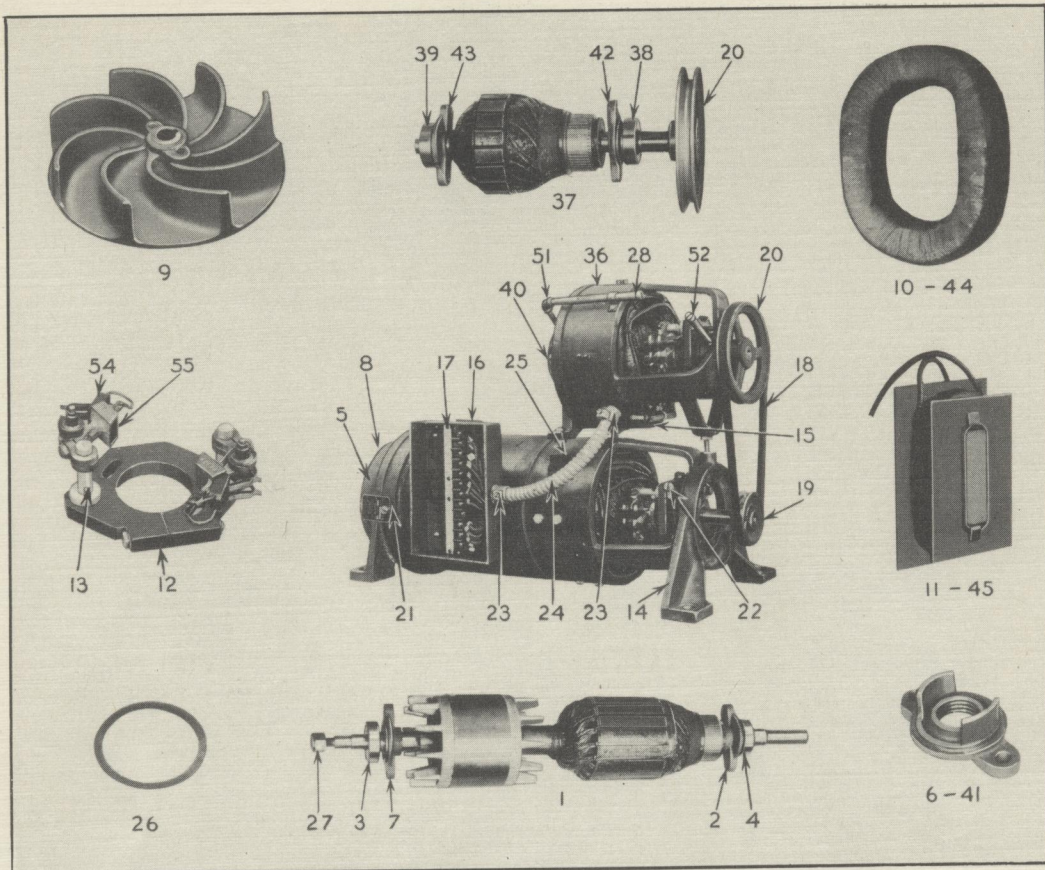

MOTOR SPARE PART LIST

1. Control Unit Rotating Element, complete with shaft, armature, and rotor.
2. Inner Cap, Control Unit, Pulley-End
3. Bearing—Control Unit, Fan-End
4. Bearing—Control Unit, Pulley-End
5. Bracket—Control Unit, Fan-End
6. Outer Cap—Control Unit, Pulley-End
7. Inner Cap—Control Unit, Fan-End
8. Cover—Fan-End Bracket
9. Fan
10. Field Coil—Generator
11. Interpole and Coil—Generator
12. Rocker—Generator and Exciter
13. Brush Stud—Generator and Exciter
14. Bracket—Control Unit Pulley-End
15. Resistor—Exciter Voltage Limiting
16. Conduit Box—Control Unit
17. Terminal Board
18. V Belt
19. Pulley—Generator
20. Pulley—Exciter
21. Grease Pipe—Fan-End
22. Grease Pipe—Pulley-End
23. Tite Bite Connector (Two)
24. Flexible Conduit ($\frac{1}{2}$ " x 10")
25. Mounting Stud—Exciter
26. Cap Gasket—Exciter and Generator
27. Elastic Stop Nut—Fan
28. Grease Pipe Plugs—Fillester Head ($\frac{3}{4}$ " x 20 x $\frac{3}{8}$ ")
29. Cap Screws—Fan-End Bracket Hex-head ($\frac{3}{8}$ " x 1") (Not Pictured)
30. Cap Screws—Pulley-End Cap Hex-head ($\frac{5}{16}$ " x 3") (Not Pictured)
31. Cap Screws—Fan-End Cap Hex-head ($\frac{5}{16}$ " x 2") (Not Pictured)
32. Cap Screws—Exciter Mounting Hex-head ($\frac{5}{16}$ " x 1") (Not Pictured)
33. Mounting Screws—Fan-End Cover Round-head ($\frac{1}{4}$ " x $\frac{3}{8}$ ") (Not Pictured)
34. Brush-stud Hex-jam Nuts (Not Pictured)
35. Lockwashers ($\frac{3}{8}$ " std.) (Not Pictured)
36. Exciter—Complete
37. Exciter Armature
38. Bearing—Front end Exciter
39. Bearing—Back-end Exciter
40. Bracket—Back-end Exciter
41. Outer Cap—Front-end Exciter
42. Inner Cap—Front-end Exciter
43. Inner Cap—Back-end Exciter
44. Field Coil—Exciter
45. Interpole and Coil—Exciter
46. Cap Screws—Exciter Back-end Bracket ($\frac{5}{16}$ " x 1") (Not Pictured)
47. Cap Screws—Exciter Front-end Cap ($\frac{5}{16}$ " x $2\frac{3}{4}$ ") (Not Pictured)
48. Cap Screws—Exciter Back-end Cap ($\frac{5}{16}$ " x $1\frac{1}{4}$ ") (Not Pictured)
49. Hex-jam Nuts—Exciter—Brush Stud (Not Pictured)
50. Brass Nipple—Exciter Back-end ($\frac{1}{8}$ " x $3\frac{1}{2}$ ") (Not Pictured)
51. Grease Pipe—Exciter Back-end
52. Grease Pipe—Exciter Front-end
53. Cap Screws—Exciter Pole Hex Socket (Not Pictured)
54. Brushes—Generator and Exciter
55. Brush Holder—Generator and Exciter

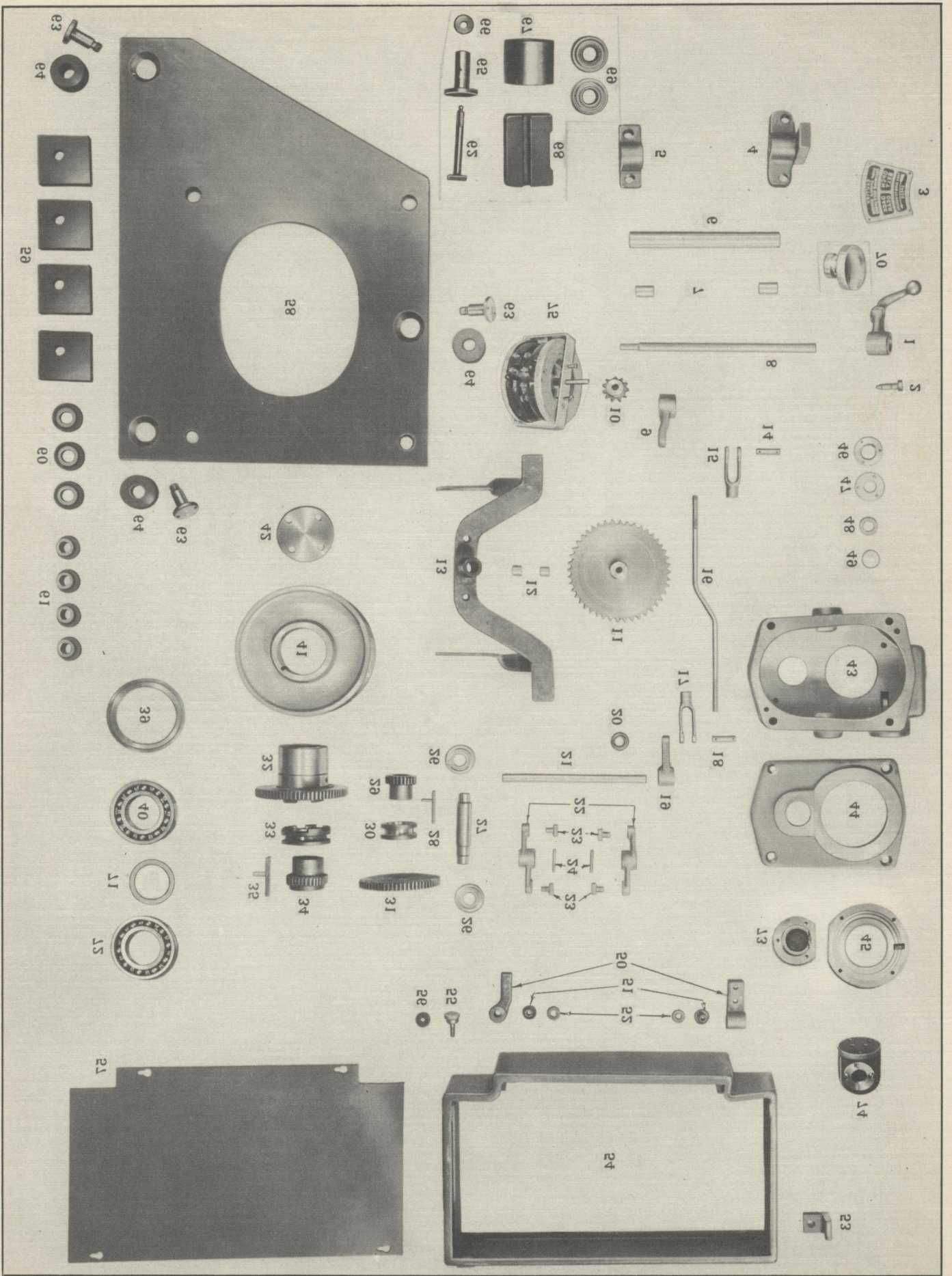

Parts Picture No. E-1-B

ЕГЕСЛІК ДВІЛЕ СОЛТВОГ

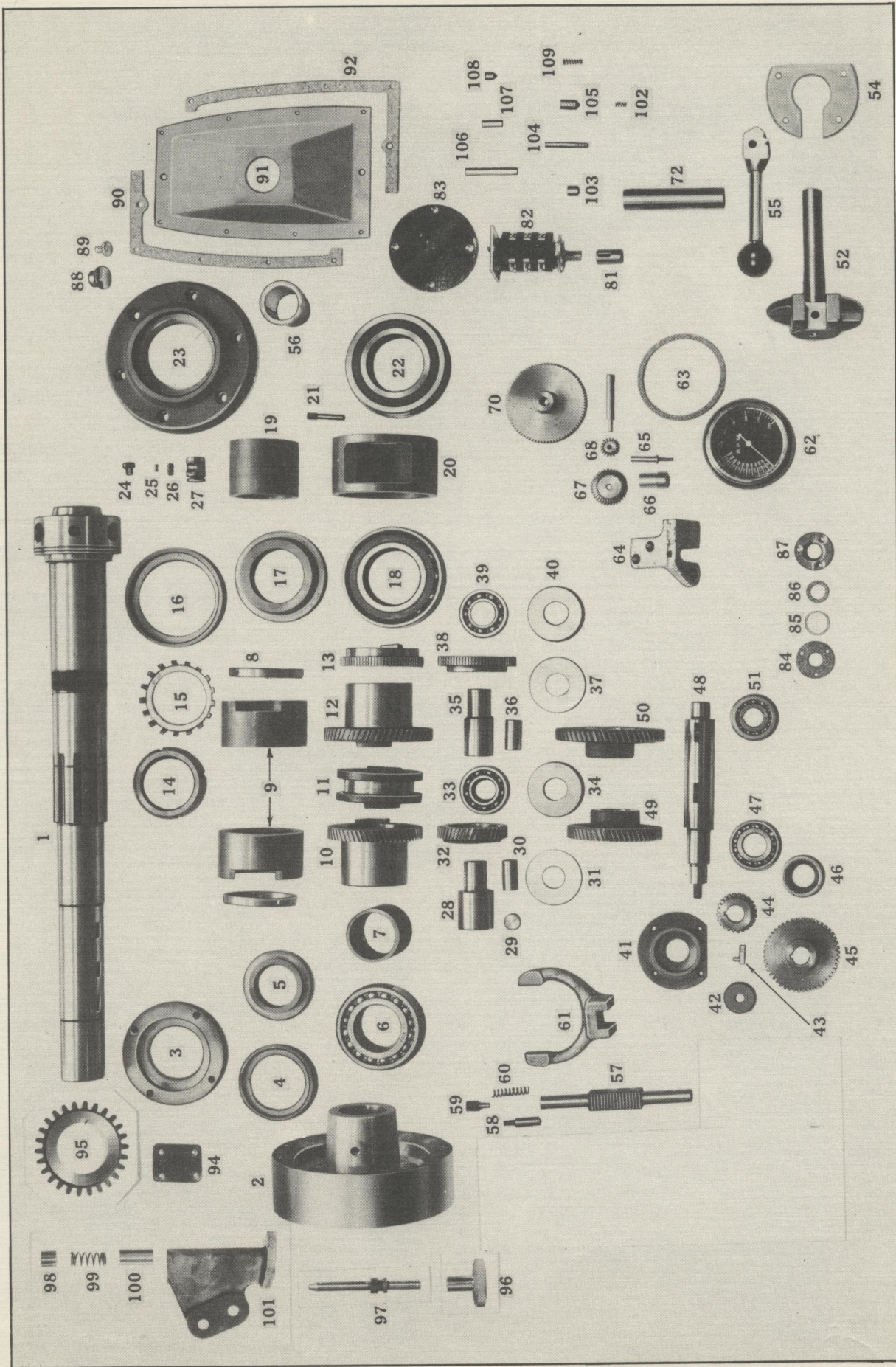

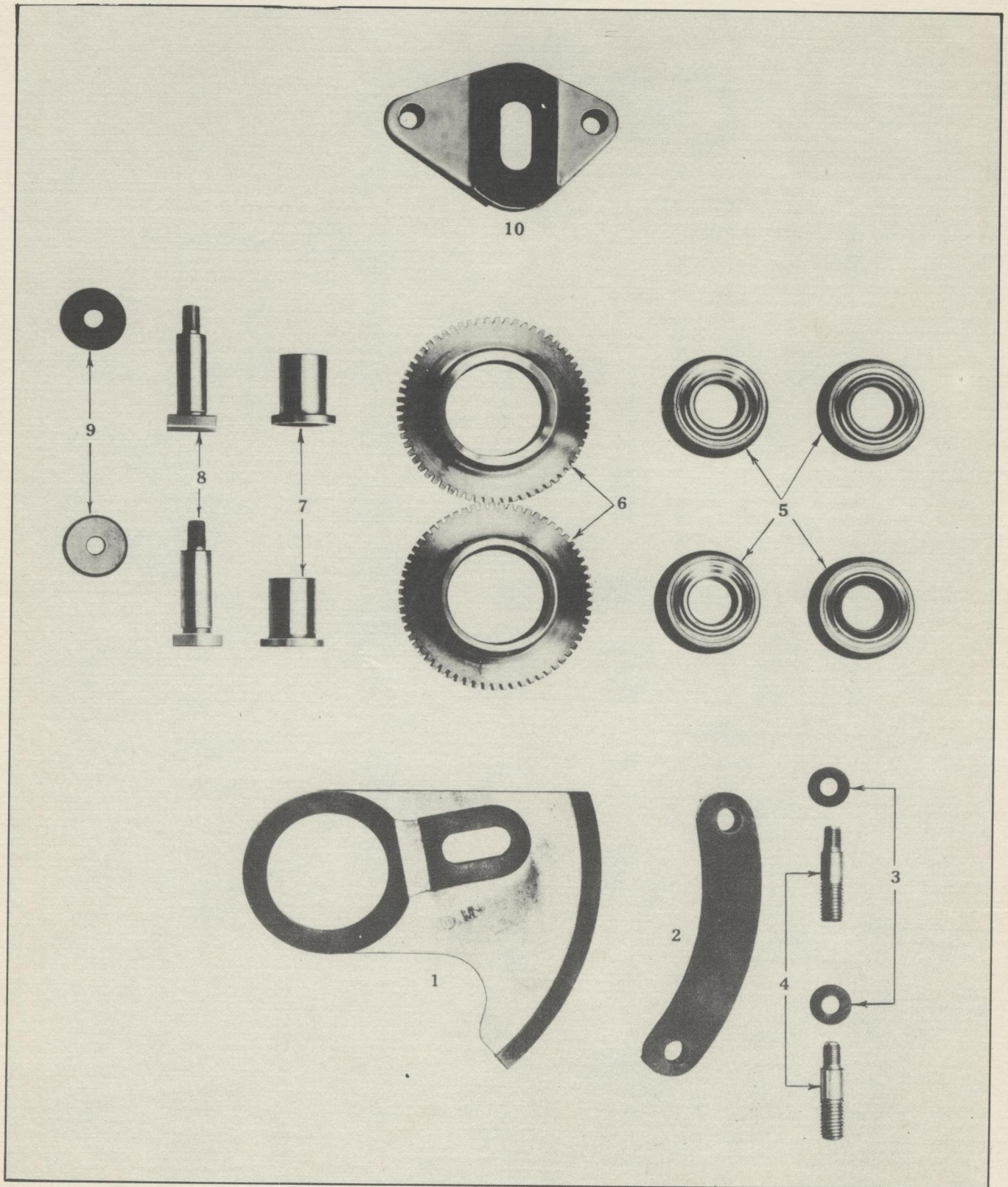

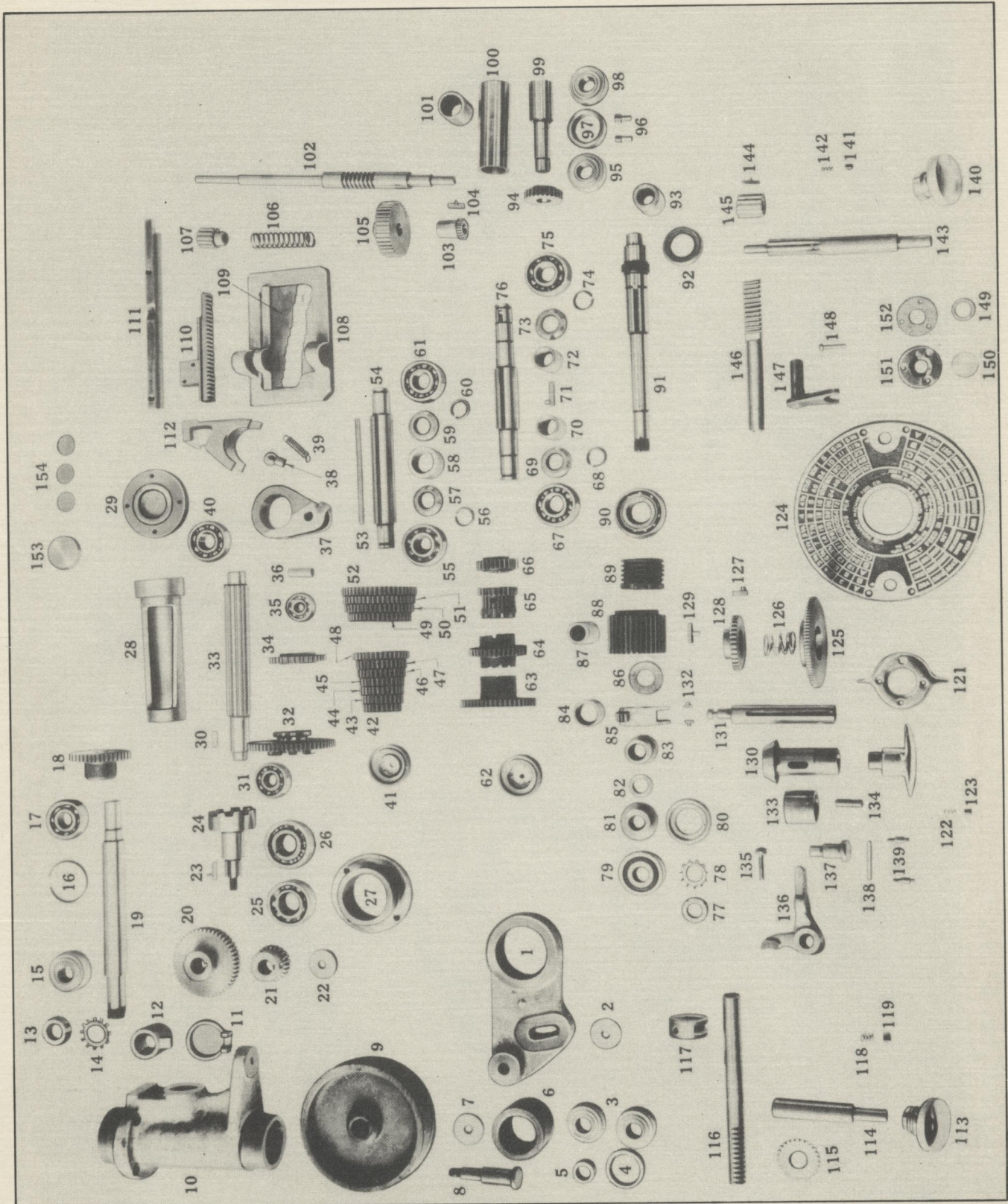

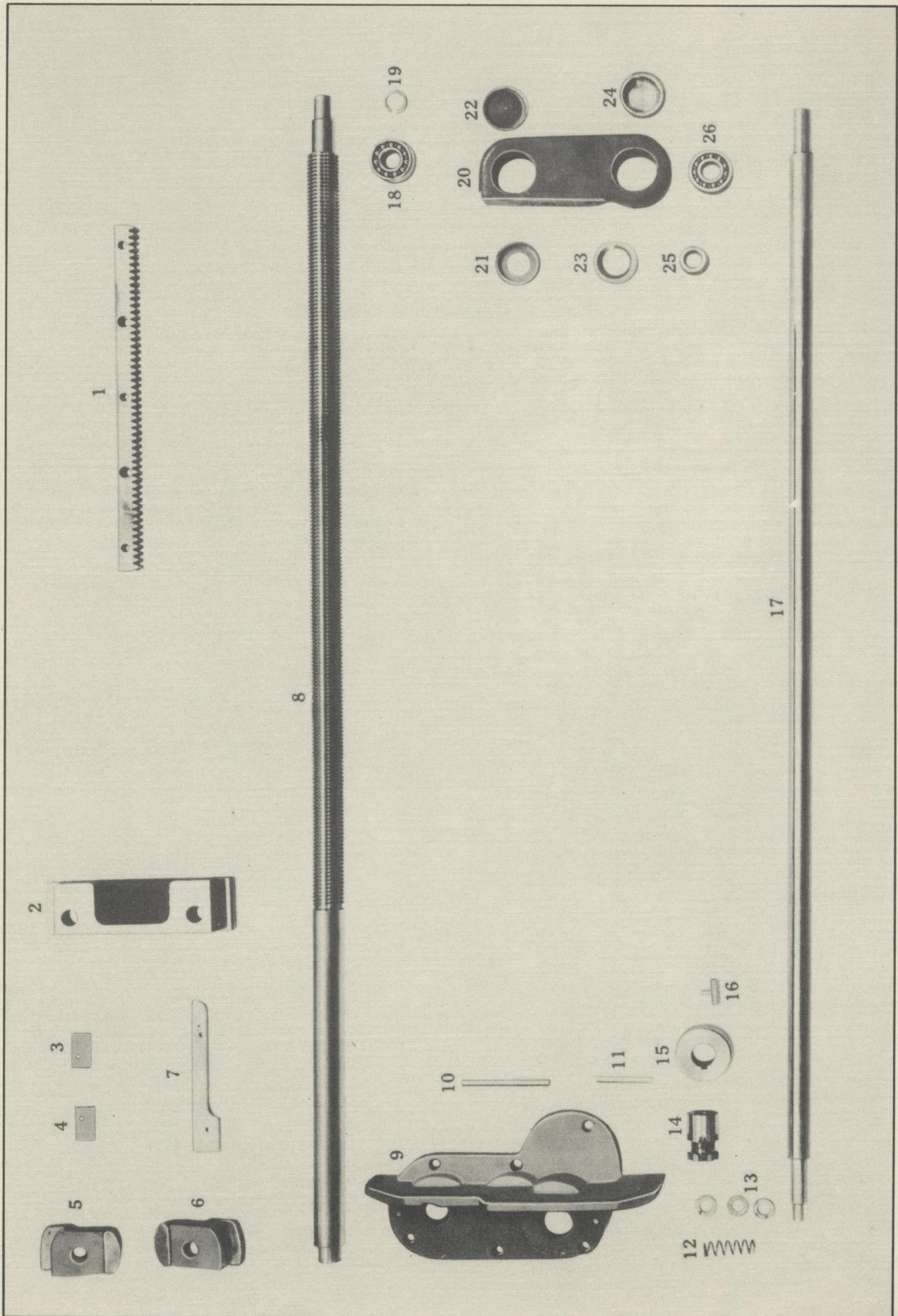

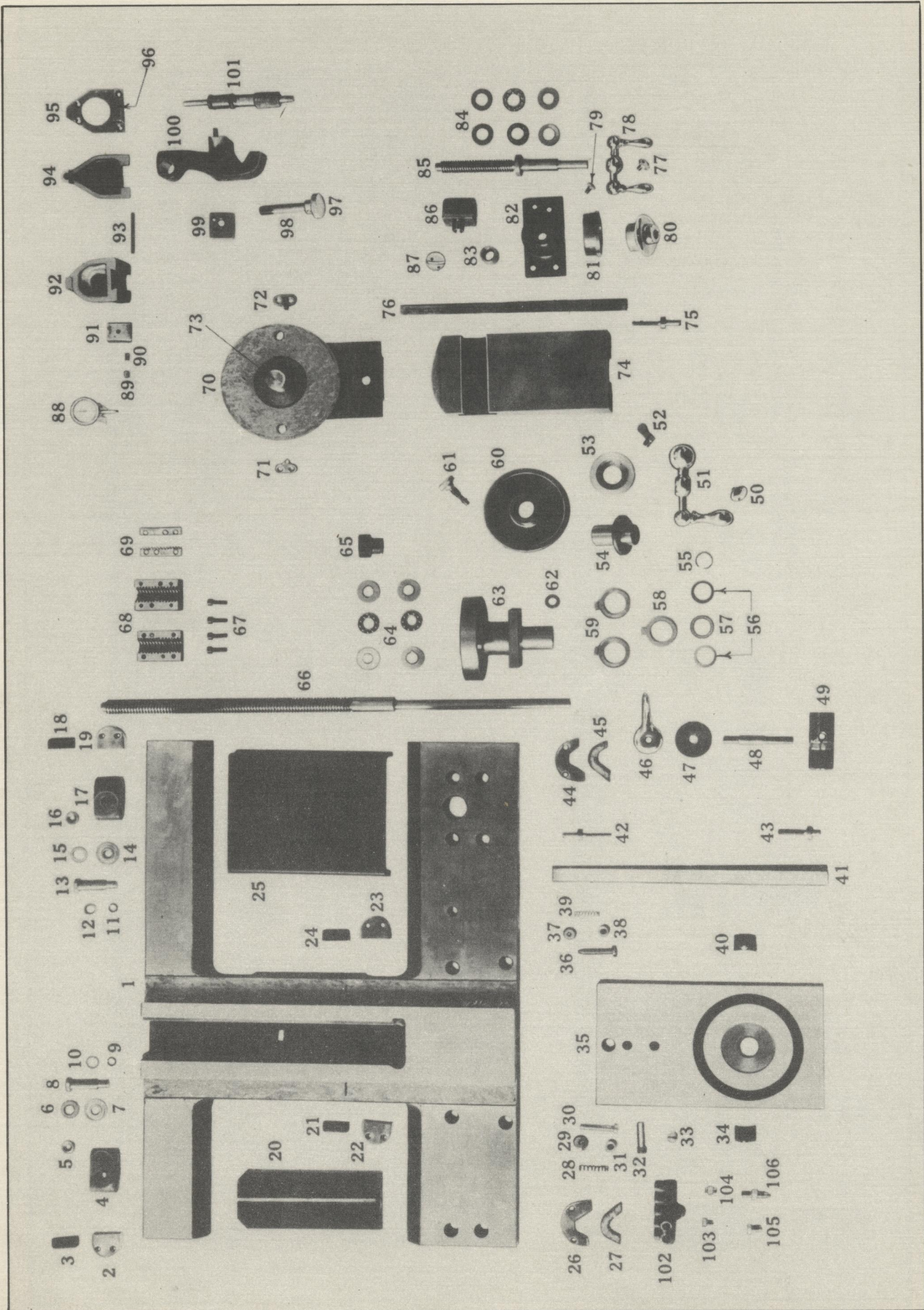

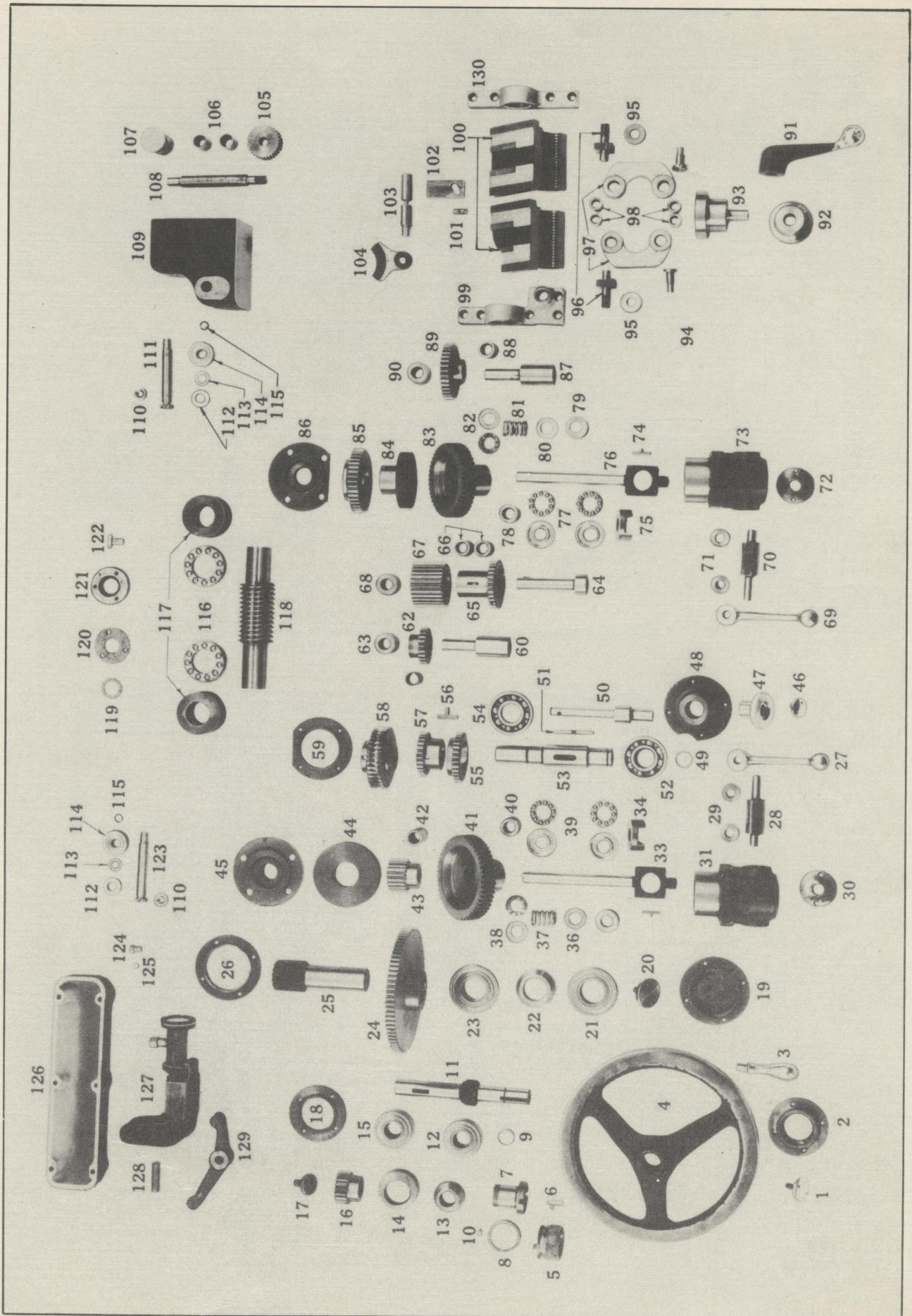

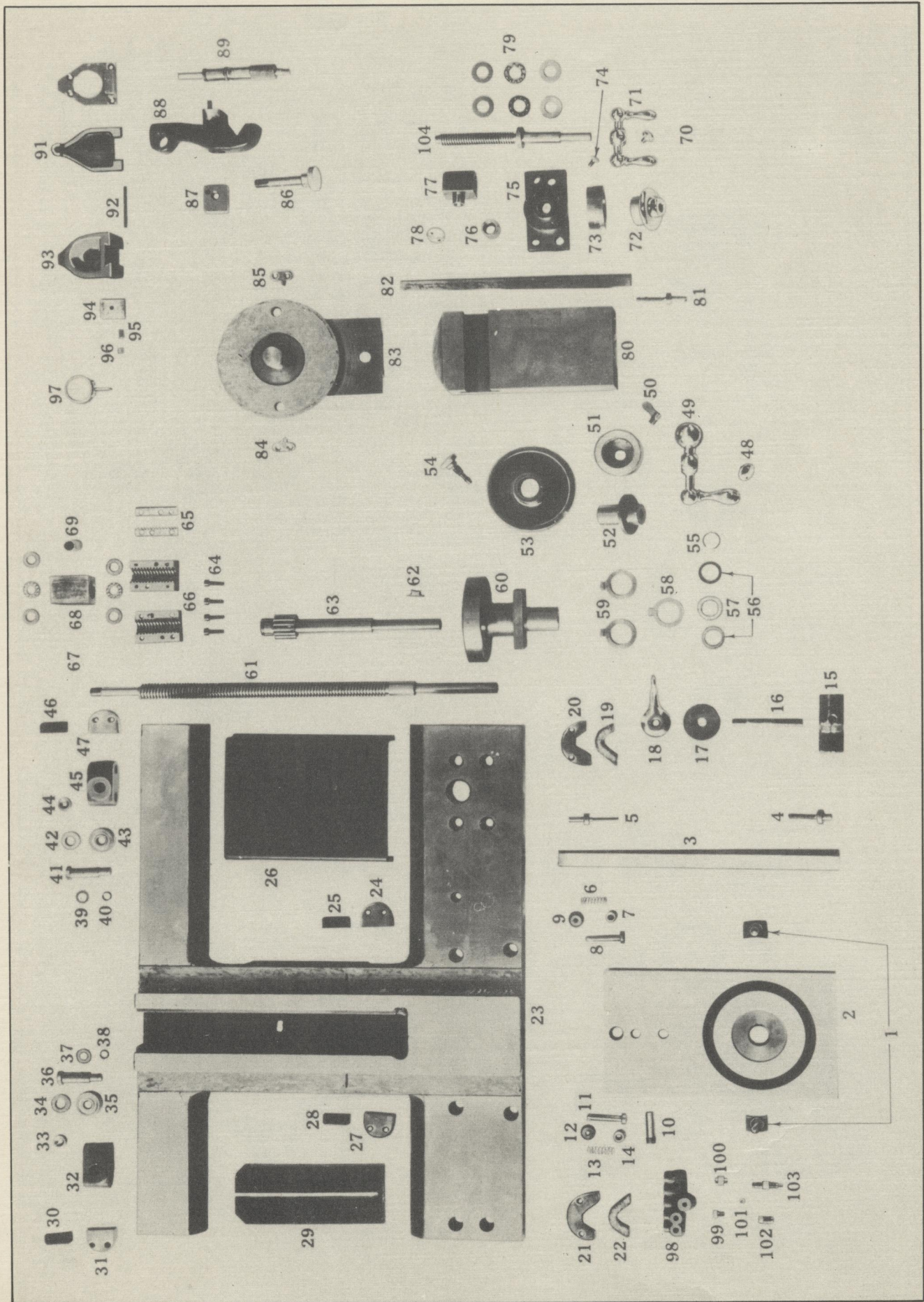

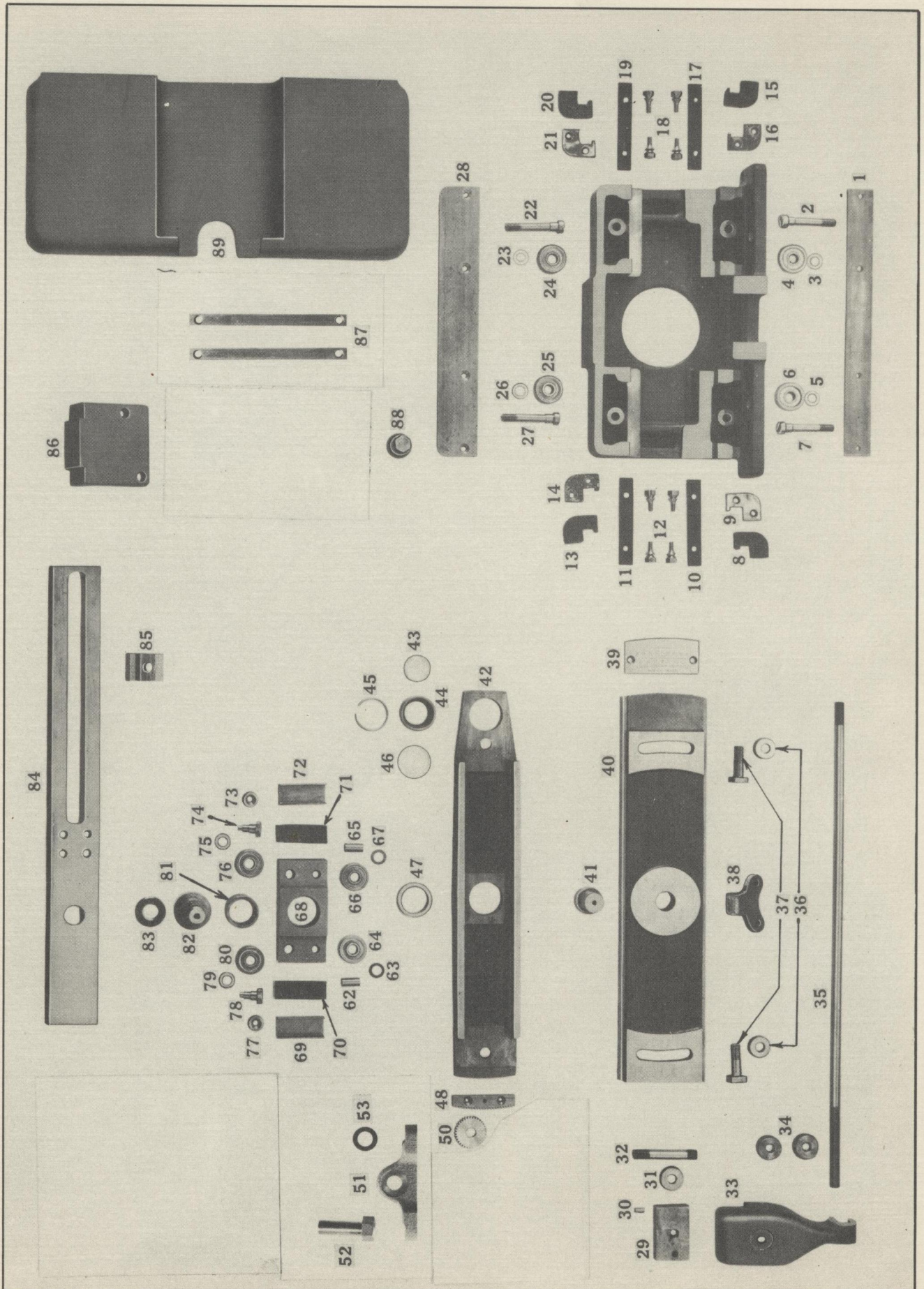

ACCESSORIES

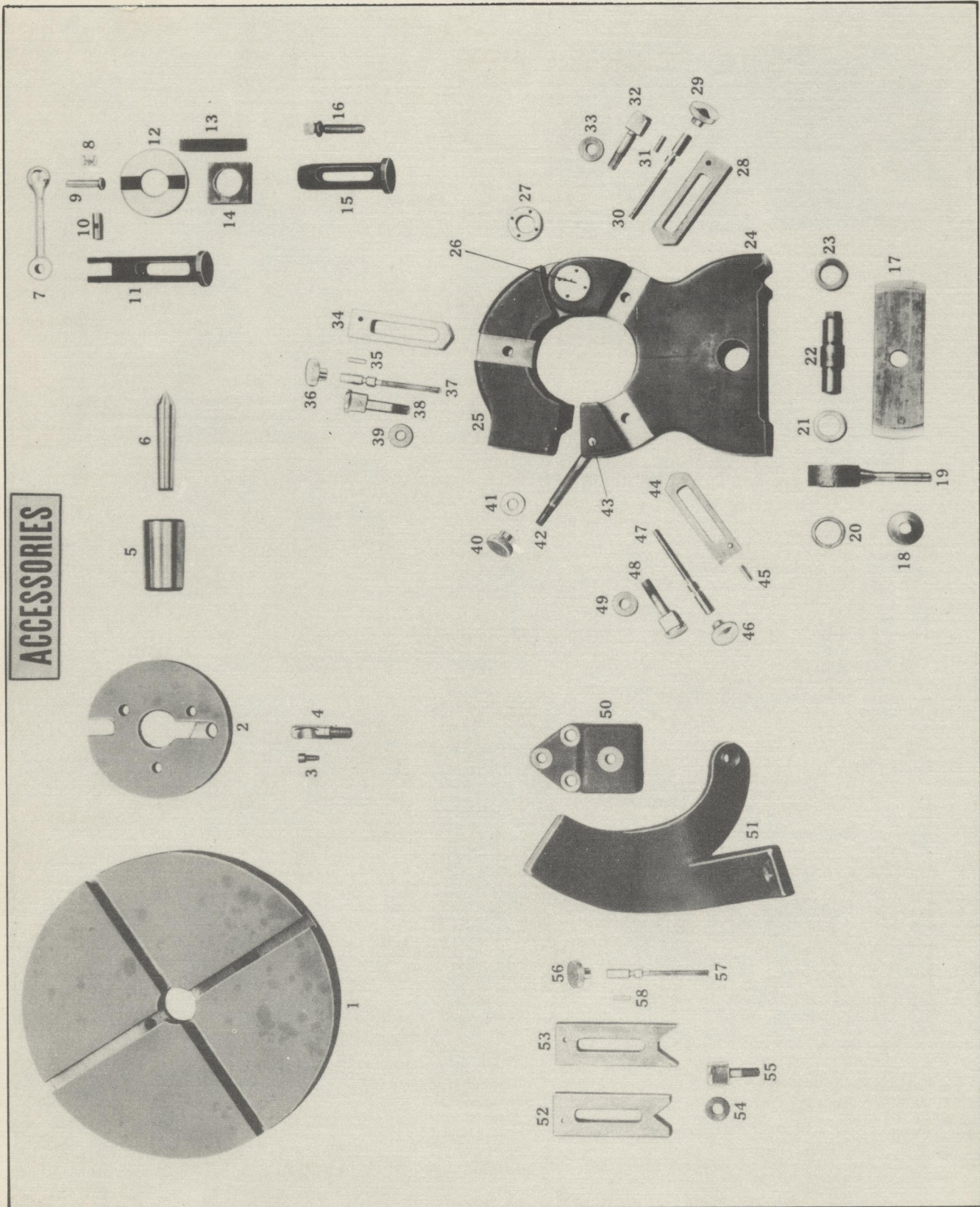

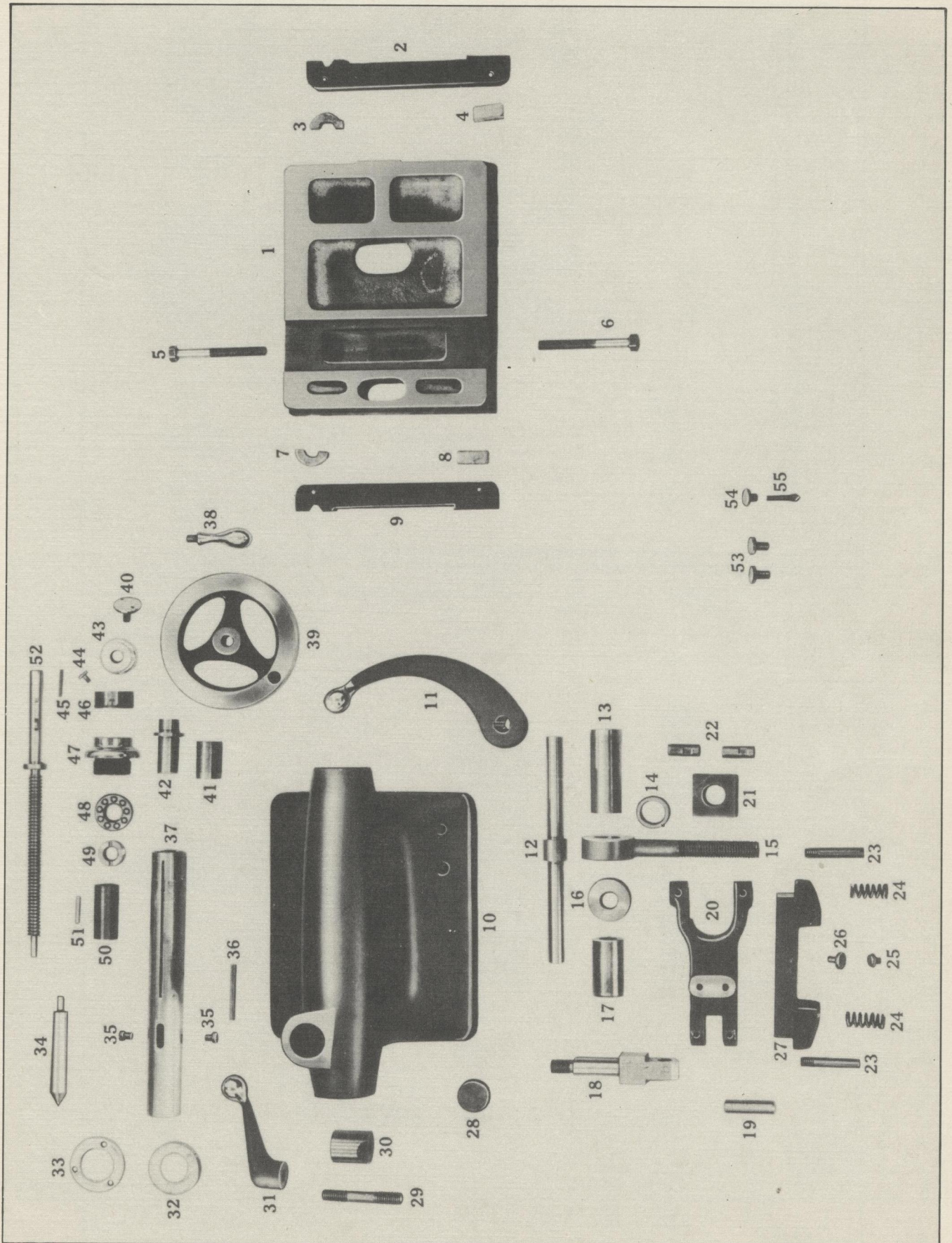

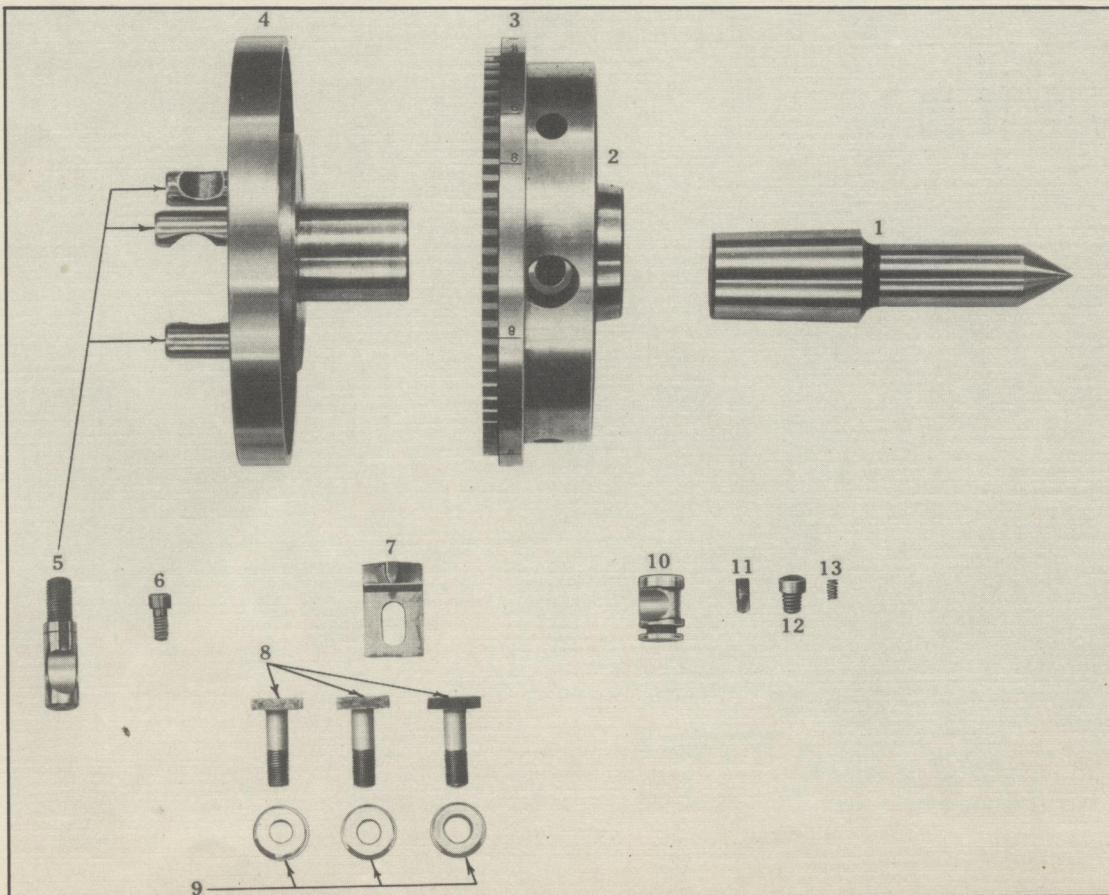
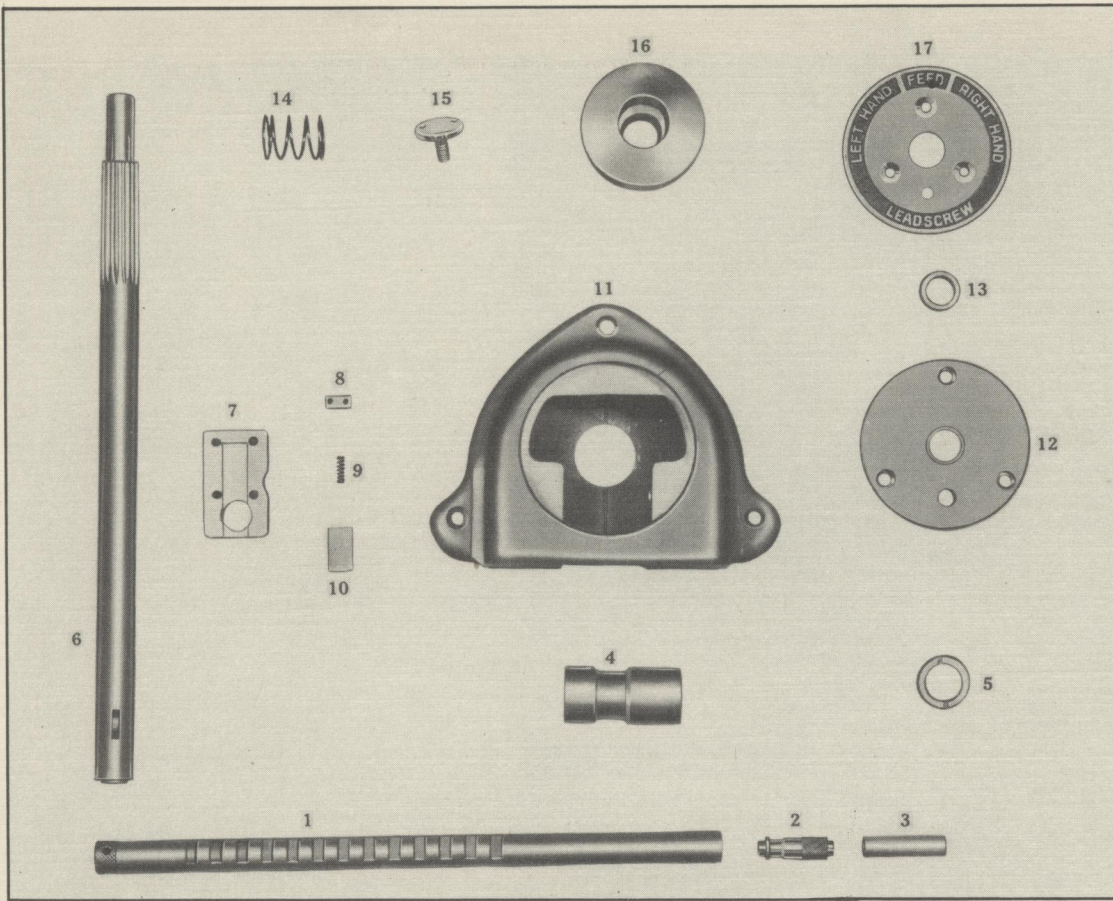

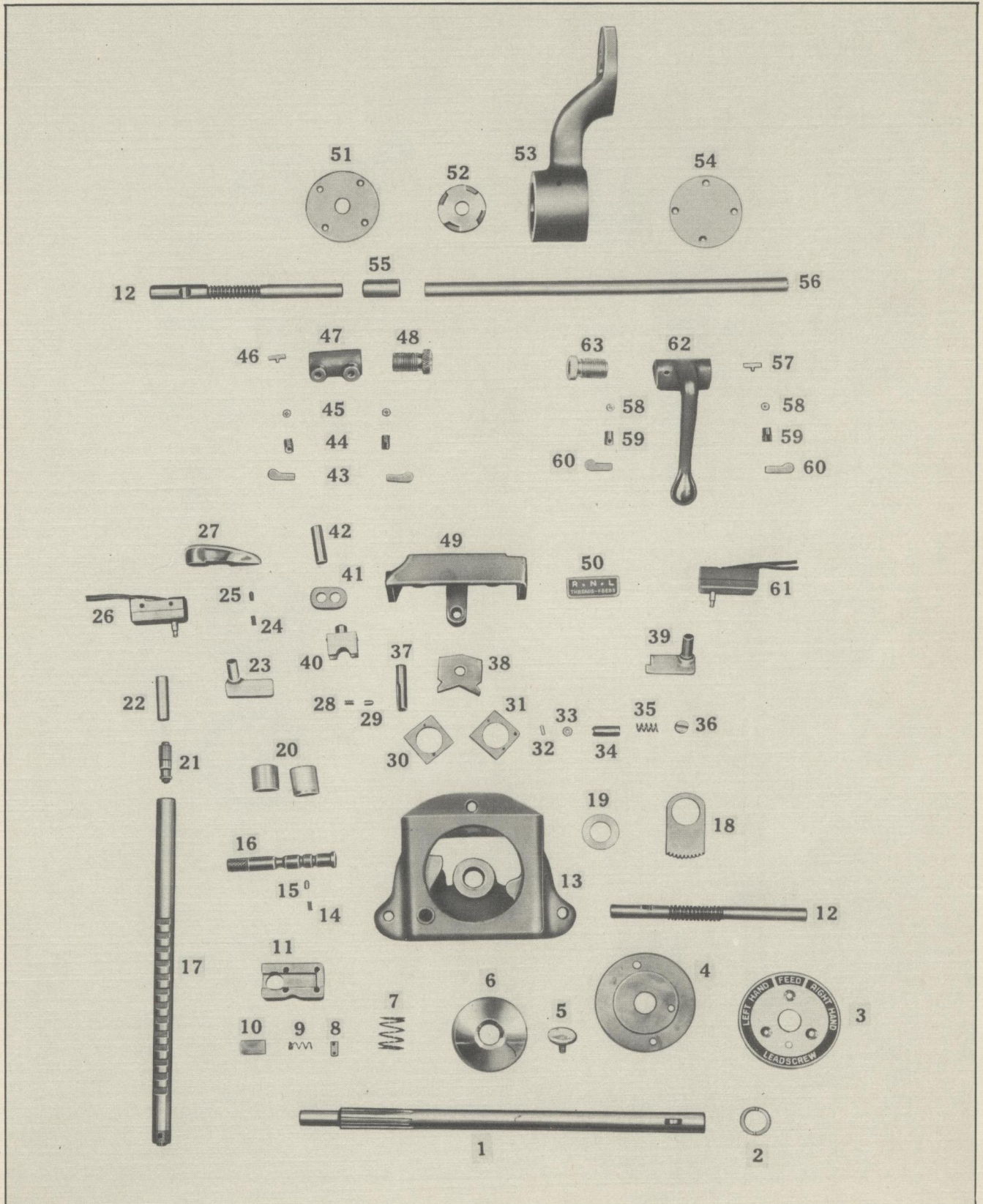

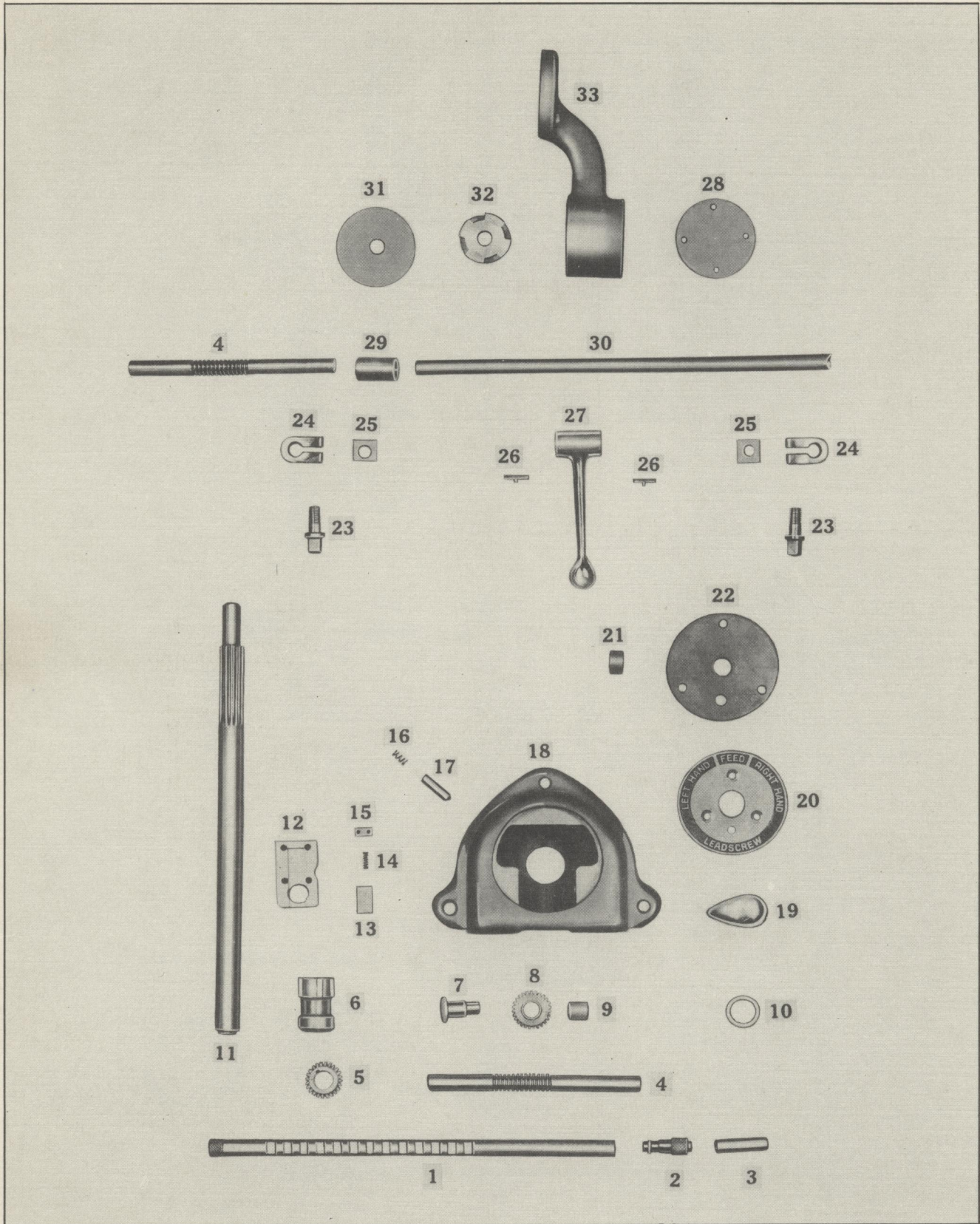

REPAIR ORDER CATALOG

INSTRUCTIONS FOR ORDERING PARTS—

When ordering parts there are five points of information that must be sent. These are as follows:

1. The amount of pieces required.
2. The name of the part.
3. The number of the part.
4. The parts picture number.
5. The lathe serial number.

(Note—This number is of utmost importance. It is found on the name plate, which is mounted on the front of the headstock, and it is also stamped on the front way of the bed at the tailstock end.)

EXAMPLE OF HOW TO ORDER A PART—

Please send One Handwheel, Part Number 1, Parts Picture Number E-1, Lathe Serial Number EE-6000.

(NOTE—Use the Serial Number found on the Lathe.)



THE MONARCH MACHINE TOOL COMPANY

SIDNEY, OHIO, U. S. A.

ELECTRIC DRIVE CONTROL PARTS LIST

For Parts Picture No. E-1-B

1. Back Gear Control Lever.
2. Back Gear Lock Screw.
3. Speed Control Index Plate.
4. Front Speed Control Bracket.
5. Rear Speed Control Bracket.
6. Shifter Tube.
7. Bushing.
8. Control Shaft.
9. Upper Clevis Lever.
10. Rheostat Sprocket.
11. Lower Rheostat Sprocket.
12. Bushing.
13. Rheostat Bracket.
14. Clevis Pin.
15. Clevis.
16. Connecting Rod.
17. Clevis.
18. Clevis Pin.
19. Lower Control Lever.
20. Oil Seal.
21. Lever Shaft.
22. Shoe Lever.
23. Shoe.
24. Shoe Lever Pin.
25. Spacer (Upper Shaft).

26. Bearing.
27. Back Gear Shaft.
28. Tit Key.
29. Small Back Gear.
30. Small Back Gear Spool.
31. Large Back Gear.
32. Driven Gear.
33. Driving Clutch.
34. Driving Gear.
35. Tit Key.
36. Bearing.
37. Inner Sparer.
38. Outer Spacer.
39. Deflector.
40. Bearing Snap Ring.
41. Elect. Back Gear Unit Pulley.
42. Pulley Clamp Plate.
43. Housing.
44. Bearing Plate.
45. Cup Deflector.
46. Oil Gauge Housing.
47. Oil Gauge Housing Gasket.
48. Oil Gauge Housing Gasket.
49. Oil Gauge Glass.
50. Panel Case Hinge.

51. Hinge Insulator Bushing.
52. Washer.
53. Panel Stop Block
54. Panel Case.
55. Panel Lock Screw.
56. Grommet.
57. Panel Case Cover.
58. Drive Motor Base.
59. Motor Generator Grommet.
60. Tank Base Grommet.
61. Motor Generator Grommet.
62. Idler Tension Stud.
63. Tank Base Screw.
64. Tank Base Washer.
65. Idler Bushing.
66. Stud Washer.
67. Idler Pulley.
68. Idler Bracket.
69. Idler Pulley Bearing.
70. Speed Control Knob.
71. Bearing Spacer.
72. Bearing.
73. Bearing Cap.
74. Oil Gauge.
75. Rheostat.

HEADSTOCK PARTS LIST

For Parts Picture No. E-2-A

1. Spindle.
2. Spindle Sheave.
3. Rear Spindle Brg. Oil Def. Ret.
4. Rear Spindle Brg. Oil Deflector.
5. Rear Spindle Brg. Oil Throw Plate.
6. Rear Spindle Bearing.
7. Rear Spindle Bearing Spacer.
8. Clutch Gear Ring.
9. Reverse Gear Bushing.
10. L. H. Spindle Clutch Gear.
11. Spindle Clutch.
12. R. H. Spindle Clutch Gear.
13. Tachometer Drive Gear.
14. SKF Lock Nut.
15. SKF Lock Washer.
16. Front Spindle Brg. Oil Def.
17. Front Spindle Brg. Throw Plate.
18. Front Spindle Brg. (Inner).
19. Front Spindle Brg. Spacer (Inner).
20. Front Spindle Brg. Spacer (Outer).
21. Bearing Spacer Lock Screw.
22. Front Spindle Bearing (Outer).
23. Front Bearing Retainer Plate.
24. Detent Spring Retainer Screw.
25. Detent Spring.
26. Detent Plunger.
27. Spindle Lock Cam.
28. Reverse Idler Gear Stud L. H.
29. Reverse Idler Gear Stud Plug.
30. Reverse Idler Gear Stud Bushing.
31. Reverse Idler Gear Washer.
32. Reverse Idler Gear.
33. Reverse Idler Gear Bearing.
34. Reverse Idler Gear Lock Collar.
35. Reverse Idler Gear Stud R. H.
36. Reverse Idler Gear Stud Bushing.

37. Tachometer Splash Gear Washer.
38. Tachometer Splash Gear.
39. Tachometer Splash Gear Bearing.
40. Tachometer Splash Gear Lock Collar.
41. Reverse Shaft Bearing Cap.
42. Washer.
43. Reverse Shaft Change Gear Key.
44. 24-T Reverse Shaft Gear.
45. 48-T Reverse Shaft Gear.
(Gears Nos. 44 and 45 are interchangeable on the gearbox and are also shown on that parts picture).
46. Victor Oil Seal.
47. L. H. Bearing.
48. Reverse Shaft.
49. L. H. Reverse Shaft Gear.
50. R. H. Reverse Shaft Gear.
51. R. H. Bearing.
52. Switch Control Shaft.
54. Catch Plate.
55. Start and Stop Lever.
56. Oil Filter Screen.
57. Spindle Clutch Fork Rack.
58. Shifter Shaft Plunger.
59. Plunger Spring Adjusting Screw.
60. Plunger Spring.
61. Spindle Clutch Fork.
62. Tachometer.
63. Tachometer Gasket.
64. Bevel Gear Support.
65. Bevel Gear Stem.
66. Bevel Gear Stem Bushing.
67. Bevel Gear.
68. Bevel Pinion.
69. Bevel Pinion Stem.
70. Tachometer Driven Gear.

71. Clutch Lever.
72. Clutch Lever Shaft.
74. Bushing.
77. Connecting Link.
78. Spindle Control Plate.
80. Motor Switch Stem.
81. Motor Switch Coupling.
82. Motor Switch.
83. Motor Switch Plate (Rear).
84. Large Oil Gage Housing Gasket.
85. Oil Gage Glass.
86. Small Oil Gage Housing Gasket.
87. Oil Gage Housing.
88. Oil Plug (Large).
89. Oil Plug (Small).
90. Cover Plate Gasket (Front).
91. Cover Plate.
92. Cover Plate Gasket (Rear).
93. Oil Filter Screen.
94. Oil Reservoir Cover.
95. Spindle Lock Gear.
96. Lock Plunger Knob.
97. Lock Plunger.
98. Lock Plunger Bushing (Short).
99. Detent Spring.
100. Lock Plunger Bushing (Long).
101. Spindle Lock Bracket.
102. Spring.
103. Detent Plug.
104. Shoe Lever Pin.
105. Reverse Detent Plunger.
106. Latch Pin.
107. Pin.
108. Index Plunger.
109. Spring.

END GEARING PARTS LIST

For Parts Picture No. E-3

1. Quadrant.
2. Quadrant Clamp.
3. Washer.
4. Quadrant Clamp Stud.

5. Quadrant Gear Bearing.
6. Quadrant Gear.
7. Quadrant Gear Stud Bushing.
8. Quadrant Gear Stud.

9. Washer.
10. Quadrant Gear Bracket.

GEAR BOX PARTS LIST

For Parts Picture No. E-4

1. Belt Tightener.
2. Washer.
3. Belt Tightener Pulley Bearing.
4. Belt Tightener Spacer (Outer).
5. Belt Tightener Spacer (Inner).
6. Belt Tightener Pulley.
7. Washer.

8. Belt Tightener Pulley Stud.
9. Feed Pulley.
10. Feed Shaft Bearing.
11. Oil Plug Cap.
12. Oil Plug.
13. Lock Nut.
14. Lock Washer.

15. Feed Shaft Bearing (L. H.).
16. Bearing Retainer Ring.
17. Feed Shaft Bearing (R. H.).
18. Feed Shaft Gear.
19. Feed Shaft.
20. 48-T Reverse Shaft Gear.

(Continued on next page)

GEAR BOX PARTS LIST—Continued

For Parts Picture No. E-4

21. 24-T Reverse Shaft Gear.
22. Washer.
23. Tit Key.
24. Change Gear Stud.
25. Change Gear Stud Bearing (L. H.)
26. Change Gear Stud Bearing (R.H.).
27. Change Gear Bearing Retainer.
28. Tumbler Shaft Sleeve.
29. Tumbler Shaft Cap.
30. Reverse Shaft Change Gear Key.
31. Tumbler Shaft Bearing (L. H.).
32. Tumbler Shaft Clutch Gear.
33. Tumbler Shaft.
34. Tumbler Gear.
35. Tumbler Gear Bearing.
36. Tumbler Gear Stud.
37. Tumbler Gear Bracket.
38. Tumbler Bracket Lock Ball.
39. Spring.
40. Tumbler Shaft Bearing (R. H.).
41. Bearing Cap.
42. 24-T Cone Gear.
43. 26-T Cone Gear.
44. 27-T Cone Gear.
45. 28-T Cone Gear.
46. 30-T Cone Gear.
47. 32-T Cone Gear.
48. 36-T Cone Gear.
49. 40-T Cone Gear.
50. 44-T Cone Gear.
51. 46-T Cone Gear.
52. 48-T Cone Gear.
53. Cone Gear Key.
54. Cone Shaft.
55. Cone Shaft Bearing (L. H.).
56. Bearing Retainer Ring.
57. Bearing Spacer (L. H.).
58. Cone Gear Spacer.
59. Bearing Spacer (R. H.).
60. Bearing Retainer Ring.
61. Cone Shaft Bearing (R. H.).
62. Bearing Cap.
63. 48-T Clutch Gear.
64. 36-T Clutch Gear.
65. 24-T Clutch Gear.

66. Clutch Shaft Gear.
67. Clutch Shaft Bearing (L. H.).
68. Bearing Retainer Ring.
69. Bearing Spacer (L. H.).
70. Clutch Gear Bushing.
71. Clutch Gear Key.
72. Clutch Gear Bushing.
73. Bearing Spacer (R. H.).
74. Bearing Retainer Ring.
75. Clutch Shaft Bearing (R. H.).
76. Clutch Shaft.
77. Lock Nut.
78. Lock Washer.
79. Leadscrew Shaft Bearing (L. H.).
80. Bearing Retainer.
81. Oil Deflector.
82. Screw Shaft Spacer (L. H.).
83. Tumbler Shifter Segment Spacer.
84. Tumbler Shifter Segment Bushing.
85. Tumbler Shifter Segment.
86. Screw Shaft Gear Spacer.
87. Screw Shaft Gear Bushing.
88. Screw Shaft Gear.
89. Screw Shaft Clutch.
90. Leadscrew Shaft Bearing (R. H.).
91. Leadscrew Shaft.
92. Victor Oil Seal.
93. Coupling.
94. Feed Rod Gear.
95. Feed Rod Stem Bearing (L. H.).
96. Bearing Spacer Dowel Pin.
97. Feed Rod Plate Brg. Spacer.
98. Feed Rod Stem Bearing (R. H.).
99. Feed Rod Stem.
100. Feed Rod Coupling.
101. Feed Rod Coupling Bushing.
102. Tumbler Lock Shaft.
103. Index Pointer Pinion.
104. Pointer Pinion Tit Key.
105. Tumbler Lock Shaft Gear.
106. Tumbler Lock Spring.
107. Tumbler Rack Pinion.
108. Tumbler Lock Plate (Front).
109. Tumbler Lock Plate (Rear).
110. Tumbler Shifter Rack.

111. Shifter Rack Guide.
112. Tumbler Shifter Fork.
113. Clutch Shifter Knob.
114. Clutch Shifter Stud.
115. Clutch Shifter Gear.
116. Clutch Shifter Rack.
117. Clutch Shifter Fork.
118. Spring.
119. Plunger.
120. Index Shaft Knob.
121. Index Pointer.
122. Spring.
123. Plunger.
124. Thread and Feed Dial.
125. Index Pointer Gear.
126. Index Gear Spring.
127. Index Gear Tit Key.
128. Index Shaft Gear.
129. Tit Key.
130. Tumbler Release Plunger.
131. Index Shaft.
132. Index Shaft Shoe.
133. Front Plate Bushing.
134. Index Shaft Drive Pin.
135. Tumbler Lock Button.
136. Tumbler Lock.
137. Tumbler Lock Stud.
138. Tumbler Lock Pin.
139. Tumbler Lock Spring Stud.
140. Feed Shifter Knob.
141. Plunger.
142. Spring.
143. Feed Shifter Pinion.
144. Tit Key.
145. Feed Shifter Rack Pinion.
146. Feed Shifter Rack.
147. Feed Shifter Fork.
148. Feed Shifter Fork Pin.
149. Oil Gage Housing Gasket.
150. Oil Gage Glass.
151. Oil Gage Housing.
152. Feed Shaft Plug.
153. Feed Shaft Plug.
154. Shifter Rack Plug.

BED PARTS LIST

For Parts Picture No. E-5

1. Feed Rack.
2. Front Headstock Clamp.
3. Bed Filler Strip.
4. Bed Filler Strip.
5. Rear Headstock Clamp (Rear).
6. Rear Headstock Clamp (Front).
7. Bed Filler Strip.
8. Leadscrew.
9. Feed Rod Plate.

10. Feed Rod Plate Pin (Long).
11. Feed Rod Plate Pin (Short).
12. Feed Rod Stop Spring.
13. Thrust Bearing.
14. Feed Rod Clutch.
15. Stop Collar.
16. Tit Key.
17. Feed Rod.
18. Leadscrew Bearing.

19. Bearing Retaining Ring.
20. Leadscrew Bearing Plate.
21. Cup Deflector.
22. Cup Deflector.
23. Feed Rod Bearing Retainer (L. H.).
24. Feed Rod Bearing Retainer (R.H.).
25. Feed Rod Bearing Spacer.
26. Feed Rod Bearing.

APRON PARTS LIST

For Parts Picture No. E-6

1. Handwheel Retaining Screw.
2. Bearing Retainer (Front).
3. Machine Handle.
4. Handwheel.
5. Handwheel Clutch.
6. Tit Key.
7. Handwheel Clutch Bushing.
8. Handwheel Clutch Snap Ring.
9. Wormwheel Shaft Snap Ring.
10. Handwheel Clutch Plunger.
11. Handwheel Stem.
12. Front Handwheel Stem Bearing.
13. Handwheel Pinion Spacer.
14. Pump Cam.
15. Rear Handwheel Stem Bearing.
16. Handwheel Pinion.
17. Bearing Retaining Screw.
18. Bearing Retainer (Rear).
19. Rack Pinion Bearing Cap (Front).
20. Bearing Retaining Screw.
21. Rack Pinion Bearing (Front).
22. Rack Pinion Bearing Spacer.
23. Rack Pinion Bearing (Rear).

24. Rack Pinion Gear.
25. Rack Pinion.
26. Rack Pinion Bearing Cap (Rear).
27. Friction Handle.
28. Friction Cam.
29. Cam Bushing.
30. Friction Stem Nut.
31. Friction Front Cap.
32. Pointer Tit Key.
33. Friction Stem.
34. Cam Washer.
35. Friction Stem Bushing.
36. Spring Washer.
37. Friction Spring.
38. Thrust Bearing.
39. Thrust Bearing.
40. Friction Stem Collar.
41. Longitudinal Friction Gear.
42. Long. Friction Pinion Bushing.
43. Long. Friction Pinion.
44. Long. Friction Disc.
45. Long. Friction Cap Rear.
46. Crank Retaining Screw.

47. Reverse Knob.
48. Wormwheel Bearing Cap (Front).
49. Wormwheel Shaft Snap Ring.
50. Reverse Shifter.
51. Reverse Shifter Pin.
52. Wormwheel Shaft Bearing (Front).
53. Wormwheel Shaft.
54. Wormwheel Shaft Bearing (Rear).
55. 32-T Reverse Gear.
56. Tit Key.
57. 28-T Reverse Gear.
58. Wormwheel.
59. Wormwheel Bearing Cap (Rear).
60. Idler Gear Stud.
61. Idler Gear Bushing.
62. 24-T Idler Gear.
63. Idler Gear Spacer.
64. Compound Gear Stud.
65. 32-T Compound Gear.
66. Compound Gear Bushing.
67. 28-T Compound Gear.
68. Idler Gear Spacer.

(Continued on next page)

APRON PARTS LIST—Continued

For Parts Picture No. E-6

69. Friction Handle.	90. Idler Gear Spacer.	111. Eccentric Stud Lock Collar.
70. Cam.	91. Half Nut Lever.	112. Eccentric Bearing Washer.
71. Cam Bushing.	92. Half Nut Washer.	113. Eccentric Bearing Shim.
72. Friction Stem Nut.	93. Half Nut Cam.	114. Bearing.
73. Friction Front Cap.	94. Half Nut Cam Pin.	115. Eccentric Bearing Retaining Ring.
74. Pointer Tit Key.	95. Washer.	116. Worm Thrust Bearing.
75. Cam Washer.	96. Half Nut Arm Bolt.	117. Worm Bushing.
76. Friction Stem.	97. Half Nut Arm.	118. Worm.
77. Thrust Bearing.	98. Half Nut Arm Bushing.	119. Oil Gage Housing Gasket (Small).
78. Friction Stem Collar.	99. Half Nut Clamp (L. H.).	120. Oil Gage Housing Gasket (Large).
79. Friction Stem Bushing.	100. Half Nut.	121. Oil Gage Housing.
80. Spring Washer.	101. Interlocking Bar Pin.	122. Oil Plug.
81. Friction Spring.	102. Interlocking Bar.	123. Take-up Bearing Eccentric Stud.
82. Thrust Bearing.	103. Interlocking Fork Shaft.	124. Oil Compression Bushing.
83. Cross Feed Friction Gear.	104. Interlocking Fork.	125. Oil Compression Sleeve.
84. Cross Feed Friction Disc.	105. Chasing Dial Worm.	126. Pump Housing.
85. Cross Feed Friction Disc Gear.	106. Chasing Dial Stem Bushing.	127. Oil Pump.
86. Cross Feed Friction Cap Rear.	107. Chasing Dial.	128. Pump Cam Follower Pin.
87. 36-T Idler Gear Stud.	108. Chasing Dial Stem.	129. Pump Cam Follower.
88. Idler Gear Bushing.	109. Chasing Dial Bracket.	130. Half Nut Clamp (R. H.).
89. 36-T Idler Gear.	110. Take-up Bearing Eccentric Stud.	

CARRIAGE WITH REGULAR SCREW PARTS LIST

For Parts Picture No. E-7

1. Carriage.	37. Spring Stem Collar.	73. Swivel Pin.
2. Flat Wiper Case.	38. Spring Retaining Bushing.	74. Top Slide.
3. Carriage Flat Wiper.	39. Spring.	75. Top Slide Gib Screw.
4. Take Up Bearing Bracket (L. H.).	40. Swivel Bolt.	76. Top Slide Gib.
5. Eccentric Stud Lock Collar.	41. Bottom Slide Gib.	77. Retaining Screw.
6. Eccentric Bearing Washer.	42. Rear Gib Screw.	78. Compound Rest Handle.
7. Carriage Hold Down Bearing.	43. Front Gib Screw.	79. Micrometer Dial Lock Screw.
8. Take Up Eccentric Bearing Stud.	44. Vee Wiper Case (R. H.).	80. Driving Collar.
9. Eccentric Bearing Retaining Ring.	45. Carriage Vee Wiper.	81. Micrometer Dial.
10. Bearing Shim.	46. Binder Clamp Lever.	82. Compound Screw Bushing.
11. Eccentric Bearing Retaining Ring.	47. Binder Clamp Washer.	83. Screw Bushing.
12. Bearing Shim.	48. Binder Clamp Stud.	84. Thrust Bearing.
13. Take Up Bearing Eccentric Stud.	49. Binder Clamp.	85. Compound Screw.
14. Carriage Hold Down Bearing.	50. Crank Retaining Screw.	86. Compound Screw Nut.
15. Eccentric Bearing Washer.	51. Ball Crank.	87. Retaining Screw.
16. Eccentric Stud Lock Collar.	52. Dial Lock Screw.	88. Indicator.
17. Take Up Bearing Bracket (R. H.).	53. Micrometer Dial Lock Collar.	89. Binder Plug.
18. Carriage Flat Wiper.	54. Micrometer Dial Bushing.	90. Clamp Pin.
19. Flat Wiper Case.	55. Felt Washer Retaining Ring.	91. Indicator Bracket Dovetail.
20. Dust Plate.	56. Felt Retaining Washer.	92. Indicator Bracket.
21. Carriage Flat Wiper.	57. Felt Washer.	93. Cover Hinge Pin.
22. Flat Wiper Case.	58. Lock Collar.	94. Indicator Cover.
23. Carriage Flat Wiper.	59. Loose Collar.	95. Indicator Bracket Cover Plate.
24. Flat Wiper Case.	60. Cross Feed Micrometer Dial.	96. Hinge Block.
25. Dust Cover.	61. Stop Screw.	97. Knob.
26. Vee Wiper Case (L. H.).	62. Screw Bushing.	98. Clamp Stud.
27. Carriage Vee Wiper.	63. Regular Cross Feed Screw Bushing.	99. Micrometer Bracket Clamp.
28. Spring.	64. Thrust Bearing.	100. Micrometer Bracket.
29. Spring Stem Collar.	65. Cross Feed Screw Pinion.	101. Micrometer Calliper Head.
30. Spring Stem.	66. Regular Cross Feed Screw.	102. Header.
31. Spring Retaining Bushing.	67. Compensating Nut Screw.	103. Closure Plug.
32. Cross Feed Screw Nut Lock Washer.	68. Regular Compensating Nut.	104. Compression Sleeve.
33. Clamp Hole Plug.	69. Compensating Nut Shim.	105. Compression Nut.
34. Swivel Bolt.	70. Swivel.	106. Metering Pin.
35. Bottom Slide.	71. Swivel Pointer (L. H.).	
36. Spring Stem.	72. Swivel Pointer (R. H.).	

CARRIAGE WITH TELESCOPIC SCREW PARTS LIST

For Parts Picture No. E-8

1. Swivel Bolt.	22. Vee Wiper.	43. Carriage Hold Down Bearing.
2. Bottom Slide.	23. Carriage.	44. Eccentric Stud Lock Collar.
3. Bottom Slide Gib.	24. Flat Wiper Case.	45. Take-up Bearing Bracket (R. H.).
4. Front Gib Screw.	25. Flat Wiper.	46. Flat Wiper.
5. Rear Gib Screw.	26. Dust Cover.	47. Flat Wiper Case.
6. Spring.	27. Flat Wiper Case.	48. Crank Retaining Screw.
7. Spring Retaining Bushing.	28. Flat Wiper.	49. Ball Crank.
8. Spring Stem.	29. Dust Plate.	50. Dial Lock Screw.
9. Spring Stem Collar.	30. Flat Wiper.	51. Micrometer Dial Lock Collar.
10. Cross Feed Screw Nut Lock Screw.	31. Flat Wiper Case.	52. Micrometer Dial Bushing.
11. Spring Stem.	32. Take Up Bearing Bracket (L. H.).	53. Micrometer Dial.
12. Spring Stem Collar.	33. Eccentric Stud Locker Collar.	54. Stop Screw.
13. Spring.	34. Eccentric Bearing Washer.	55. Felt Washer Retaining Ring.
14. Spring Retaining Bushing.	35. Carriage Hold Down Bearing.	56. Felt Retaining Washer.
15. Binder Clamp.	36. Take-up Eccentric Bearing Stud.	57. Felt Washer.
16. Binder Clamp Stud.	37. Bearing Shim.	58. Lock Collar.
17. Binder Clamp Washer.	38. Eccentric Bearing Retaining Ring.	59. Loose Collar.
18. Binder Clamp Lever.	39. Bearing Shim.	60. Cross Feed Screw Bushing.
19. Vee Wiper.	40. Eccentric Bearing Retaining Ring.	61. Telescopic Cross Feed Screw.
20. Vee Wiper Case (R. H.).	41. Take-up Bearing Eccentric Stud.	62. Sleeve Key.
21. Vee Wiper Case (L. H.).	42. Eccentric Bearing Washer.	

(Continued on next page)

CARRIAGE WITH TELESCOPIC SCREW PARTS LIST—Continued For Parts Picture No. E-8

63. Cross Feed Screw Sleeve.	77. Compound Screw Nut.	91. Indicator Cover.
64. Compensating Nut Screw.	78. Retaining Screw.	92. Cover Hinge Pin.
65. Compensating Nut Shim.	79. Thrust Bearing.	93. Indicator Bracket.
66. Telescopic Compensating Nut.	80. Top Slide.	94. Indicator Bracket Dovetail.
67. Thrust Bearing.	81. Top Slide Gib Screw.	95. Clamp Pin.
68. Rear Cross Feed Screw Bearing.	82. Top Slide Gib.	96. Binder Plug.
69. Rear Cross Feed Screw Bear. Bush.	83. Swivel.	97. Indicator.
70. Retaining Screw.	84. Swivel Pointer (L. H.).	98. Header.
71. Compound Rest Handle.	85. Swivel Pointer (R. H.).	99. Closure Plug.
72. Driving Collar.	86. Clamp Stud and Knob.	100. Compression Sleeve.
73. Micrometer Dial.	87. Micrometer Bracket Clamp.	101. Compression Bushing.
74. Micrometer Dial Lock Screw.	88. Micrometer Bracket.	102. Compression Nut.
75. Compound Screw Bushing.	89. Micrometer Calliper Head.	103. Metering Pin.
76. Screw Bushing.	90. Indicator Bracket Cover Plate.	104. Compound Screw.

TAPER ATTACHMENT PARTS LIST For Parts Picture No. E-9

1. Slide Gib (Front).	28. Slide Gib (Rear).	64. Shoe Bearing.
2. Slide Bearing Stud.	29. Bed Bracket Clamp.	65. Shoe Bearing Pin.
3. Bearing Shim.	30. Clamp Pin.	66. Bearing Shim.
4. Front R. H. Bearing.	31. Washer.	67. Shoe Bearing.
5. Front L. H. Bearing.	32. Bed Bracket Stud.	68. Shoe.
6. Bearing Shim.	33. Bed Bracket.	69. Shoe Wiper Plate.
7. Slide Bearing Eccentric Stud.	34. Draw Rod Nut.	70. Shoe Wiper.
8. Slide Wiper.	35. Draw Rod.	71. Shoe Wiper.
9. Slide Wiper Plate (Front L. H.).	36. Washer.	72. Shoe Wiper Plate.
10. Bracket Insert.	37. Swivel Clamp Stud.	73. Eccentric Stud Lock Collar.
11. Bracket Insert.	38. Draw Rod Bracket.	74. Shoe Bearing Eccentric Stud.
12. Rivet Screw.	39. Index Plate.	75. Bearing Shim.
13. Slide Wiper.	40. Slide.	76. Shoe Bearing.
14. Slide Wiper Plate (Rear L. H.).	41. Swivel Stud.	77. Eccentric Stud Lock Collar.
15. Slide Wiper.	42. Swivel.	78. Shoe Bearing Eccentric Stud.
16. Slide Wiper Plate (Front R. H.).	43. Lense.	79. Shoe Bearing Shim.
17. Bracket Insert.	44. Bezel.	80. Shoe Bearing.
18. Rivet Screw.	45. Bezel Spring.	81. Shoe Stud Bushing.
19. Bracket Insert.	46. Bezel Glass.	82. Shoe Stud.
20. Slide Wiper.	47. Swivel Bushing.	83. Stud Clamp Nut.
21. Slide Wiper Plate (Rear R. H.).	48. Rack.	84. Draw Bar.
22. Side Bearing Eccentric Stud.	50. Idler Gear.	85. Clamp Nut.
23. Bearing Shim.	51. Rack Gear Bracket.	86. Rear Bar Support.
24. Rear R. H. Bearing.	52. Rack Gear Stud.	87. Bar Rail.
25. Rear L. H. Bearing.	53. Collar.	88. Bar Rail Clamp Screw.
26. Bearing Shim.	62. Shoe Bearing Pin.	89. Dust Cover.
27. Side Bearing Eccentric Stud.	63. Bearing Shim.	

TAILSTOCK PARTS LIST For Parts Picture No. E-10

1. Base.	20. Clamp Fork.	39. Handwheel.
2. Wiper Case (R. H.).	21. Sliding Block.	40. Handwheel Retaining Screw.
3. Tailstock Vee Wiper.	22. Sliding Block Pin.	41. Bell Bushing.
4. Tailstock Flat Wiper.	23. Clamp Guide Pin.	42. Micrometer Bushing.
5. Set Over Screw.	24. Detent Spring.	43. Micrometer Dial Collar.
6. Set Over Screw.	25. Clamp Fork Button.	44. Micrometer Dial Lock Screw.
7. Tailstock Vee Wiper.	26. Clamp Button.	45. Handwheel Key.
8. Tailstock Flat Wiper.	27. Clamp.	46. Micrometer Dial.
9. Wiper Case (L. H.).	28. Eccentric Shaft Plug.	47. Tailstock Bell.
10. Tailstock Top.	29. Binder Plug Stud.	48. Thrust Bearing.
11. Eccentric Lever.	30. Binder Plug.	49. Lock Nut.
12. Eccentric Shaft.	31. Binder Plug Lever.	50. Spindle Nut.
13. Eccentric Shaft Bushing (L. H.).	32. Spindle Wiper.	51. Spindle Nut Key.
14. Eyebolt Bushing.	33. Wiper Case.	52. Tailstock Screw.
15. Eyebolt.	34. Center.	53. Oil Plug.
16. Spacer.	35. Tang Screw.	54. Center Oiler Knob.
17. Eccentric Shaft Bushing (R. H.).	36. Spindle Key.	55. Center Oiler Pin.
18. Pivot Stud.	37. Tailstock Spindle.	
19. Pivot Stud Pin.	38. Machine Handle.	

ACCESSORIES PARTS LIST For Parts Picture No. E-11

FACE PLATES AND CENTERS		28. Jaw. 29. Adjusting Screw Knob. 30. Adjusting Screw. 31. Thrust Pin. 32. Binder Screw. 33. Washer. 34. Jaw. 35. Thrust Pin. 36. Adjusting Screw Knob. 37. Adjusting Screw. 38. Binder Screw. 39. Washer. 40. Eye Bolt Knob. 41. Washer.	
1. Face Plate.	14. Tool Post Block		
2. Dog Plate.	15. Tool Post (Screw Type).		
3. Stud Locking Screw.	16. Tool Post Screw.		
4. Cam Locking Stud.	STEADY REST		
5. Spindle Bushing.	17. Clamp.		
6. Center.	18. Clamp Washer.		
TOOL POSTS			
7. Cam Lever.	19. Eccentric Eye Bolt.		
8. Tool Post Plunger Spring.	20. Eccentric Eye Bolt Bushing.		
9. Tool Post Plunger.	21. Eccentric Stem Bushing.		
10. Cam Lever Pin.	22. Eccentric Stem.		
11. Tool Post (Quick Clamping).	23. Eccentric Stem Bushing.		
12. Tool Post Collar.	24. Steady Rest Base.		
13. Wedge.	25. Steady Rest Top.		
	26. Hinge Bolt.		
	27. Hinge Bolt Nut.		

(Continued on next page)

ACCESSORIES PARTS LIST—Continued
For Parts Picture No. E-11

42. Eye Bolt.	48. Binder Screw.	53. Jaw ($\frac{3}{4}$ " to $1\frac{1}{2}$ " capacity).
43. Eye Bolt Pin.	49. Washer.	54. Washer.
44. Jaw.	FOLLOW REST	
45. Thrust Pin.	50. Jaw Bracket.	55. Binder Screw.
46. Adjusting Screw Knob.	51. Follow Rest Bracket.	56. Adjusting Screw Knob.
47. Adjusting Screw.	52. Jaw ($\frac{1}{8}$ " to $\frac{3}{4}$ " capacity).	57. Adjusting Screw.
		58. Thrust Pin.

MULTI THREAD INDEXING ATTACHMENT PARTS LIST
For Parts Picture No. E-12

1. Headstock Center.	6. Stud Locking Screw.	11. Detent Plunger.
2. Sub Nose.	7. Indexing Latch.	12. Detent Spring Retaining Screw.
3. Index Ring.	8. Clamp Bolt.	13. Detent Spring.
4. Hub.	9. Washer.	
5. Cam Lock Stud.	10. Spindle Lock Cam.	

REGULAR LEADSCREW REVERSE SHIFTER PARTS LIST
For Parts Picture No. E-13

1. Stop Rod.	7. Stop Rod Latch Case.	13. Housing Plate Bushing.
2. Micrometer Head.	8. Latch Slot Plug.	14. Index Gear Spring.
3. Micrometer Head Bushing.	9. Spring.	15. Retaining Screw.
4. Detent Collar.	10. Stop Rod Latch Case.	16. Leadscrew Reverse Knob.
5. Packing Nut.	11. Reverse Control Housing.	17. Leadscrew Reverse Plate.
6. Spindle Clutch Fork Shifter Shaft.	12. Housing Plate.	

ELECTRICAL LEADSCREW REVERSE PARTS LIST
For Parts Picture No. E-14

1. Spindle Clutch Fork Shifter Shaft.	22. Micrometer Head Bushing.	43. Dial Lock Screw Finger.
2. Clutch Shifter Tube Packing Nut.	23. L. H. Switch Support.	44. Dial Lock Screw.
3. Leadscrew Reverse Plate.	24. Plunger Spring.	45. Stop Bushing Binder Plug.
4. Housing Plate.	25. Detent Plunger.	46. Tit Key.
5. Retaining Screw.	26. Micrometer Switch.	47. L. H. Saftey Stop Block.
6. Leadscrew Reverse Knob.	27. Switch Control Knob.	48. Stop Bushing.
7. Index Gear Spring.	28. Detent Spring.	49. Reverse Control Housing Cover.
8. Latch Slot Plug.	29. Detent Plunger.	50. Switch Control Plate.
9. Stop Rod Latch Spring.	30. Front Cam.	51. Nut Enclosure Plate
10. Stop Rod Latch.	31. Rear Cam.	52. Worm.
11. Stop Rod Latch Case.	32. Cam Roller Pin.	53. Nut Bracket.
12. Leadscrew Control Rod Rack.	33. Rear Cam Roller.	54. Nut Bracket Cover.
13. Reverse Control Housing.	34. Detent Plunger.	55. Control Rod Coupling.
14. Plunger Spring.	35. Plunger Spring.	56. Leadscrew Reverse Control Shaft.
15. Detent Plunger.	36. Plunger Spring Plug.	57. Tit Key.
16. Lock Plunger.	37. Cam Follower Pin.	58. Control Shaft Binder Plug.
17. Stop Rod.	38. Cam Follower.	59. Dial Lock Screw.
18. Segment.	39. R. H. Switch Support.	60. Dial Lock Screw Finger.
19. Tumbler Shifter Segment Collar.	40. Cam Follower Shoe.	61. Micrometer Switch.
20. Clutch Shifter Tube Bush.	41. Switch Control Lever.	62. Stop Bushing.
21. Micrometer Head.	42. Switch Control Lever Pin.	63. R. H. Safety Stop Lever.

MECHANICAL LEADSCREW REVERSE PARTS LIST
For Parts Picture No. E-15

1. Stop Rod.	12. Atop Rod Latch Case.	23. Safety Stop Collar Screw.
2. Micrometer Head.	13. Stop Rod Latch.	24. Safety Stop Collar.
3. Micrometer Head Bushing.	14. Spring.	25. Safety Stop Collar Key.
4. Leadscrew Control Rod Rack.	15. Latch Slot Plug.	26. Tit Key.
5. Shifter Shaft Gear.	16. Detent Spring.	27. Lever.
6. Detent Collar.	17. Detent Plunger.	28. Nut Bracket Cover.
7. Idler Stud.	18. Gear Housing.	29. Control Rod Coupling.
8. Idler Gear.	19. Indicator Knob.	30. Leadscrew Reverse Control Shaft.
9. Bushing.	20. Leadscrew Reverse Plate.	31. Leadscrew Reverse Nut Enclosure.
10. Clutch Shifter Tube Packing Nut.	21. Housing Plate Bushing.	32. Worm.
11. Spindle Clutch Fork Shifter Shaft.	22. Gear Housing Plate.	33. Nut Bracket.

ELECTRICAL REPAIR PARTS LIST

Figure E-6—Dynamic Brake Resistor.	4. NO Stationary Contact Arm.	6. N. C. Stationary Contact and Stud (Without Blowout).
Figure E-7—Model "R" Tandem Rheostat.	5. Adjustable Contact with Screw Driver Slot.	7. Spring.
Figure E-13—Dynamic Brake Relay.	6. Adjustable Contact Washer.	Figure E-17—Field Accelerating Relay.
1. Coil.	7. Adjustable Contact Lock Nut.	1. Shunt and Series Coil.
2. Resistor.	8. Moving Contact Arm and Dual Contacts.	2. Resistor.
3. Mounting stud for resistor.	9. Spring.	3. Mounting Stud for Resistor.
4. Right Hand Stationary Contact and Support Arm.	Figure E-16—Forward and Reverse Contactors, Dual 5-Pole Relay.	4. Stationary Contact.
5. Left Hand Stationary Contact and Support Arm.	1. Coil.	5. Moving Contact and Arm.
6. Two moving Contacts and Moving Contact Arms.	2. Armature Contact Blowout Coil and Contact-Arc Chute and Mounting Frame.	6. Spring.
7. Spring.	3. Field Contact Blowout Coil with Chute and Mounting Frame.	Figure D-11—Start Push-Button Station.
Figure E-14—Condenser.	4. Moving Contact Arm and Contact.	Figure F-1—Start, Stop and Reverse Drum Controller.
Figure E-15—Anti Plugging Relay.	5. N. O. Stationary Contact and Stud (Without Blowout).	Figure F-6—Pilot Light Transformer.
1. Coil.		Figure F-6—Motor Generator Starter.
2. 25000-Ohm Resistor.		
3. NC Stationary Contact Arm.		



Service Instructions • BIJUR Automatic Lubricating System

SERVICE (Meter-Units)

If one bearing receives too much oil, remove Meter-Unit and replace with one of same type but next lower Flow Rate Number. For too little oil at one bearing, replace Meter-Unit with one of same Type but next higher Flow Rate Number. Each increase in Flow Rate Number doubles oil feed. Don't attempt to adjust, disassemble, blow through or drill out Meter-Units.

SERVICE PARTS (Meter-Units)

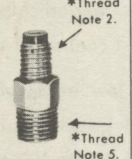
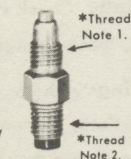
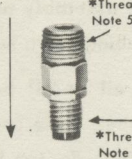
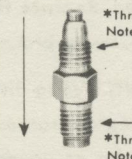
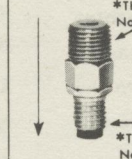
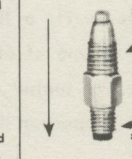
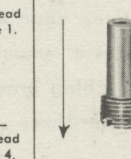
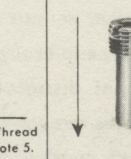
Order by Name, Type and Flow Rate Number. Example: "Meter-Unit FSA-O". Note carefully:—F and M types are different, even though they look alike, and they are not interchangeable. Type (FJD, MTK, etc.), Flow Rate Number (00, 0, 1, 2, 3, 4 or 5) and flow direction arrow are stamped on body of each Meter-Unit. All types are illustrated below (arrows show flow direction). See "Thread Notes" at bottom of page.

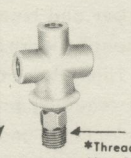
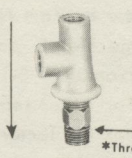
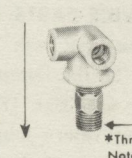
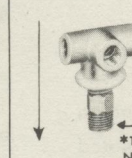
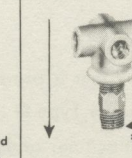
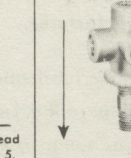
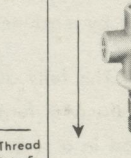
 *Thread Note 2. *Thread Note 5.	 *Thread Note 1. *Thread Note 2.	 *Thread Note 5. *Thread Note 2.	 *Thread Note 1. *Thread Note 3.	 *Thread Note 5. *Thread Note 3.	 *Thread Note 1. *Thread Note 4.	 *Thread Note 5.	 *Thread Note 5.
FSA or MSA	FJB or MJB	FRA or MRA	FJC or MJC	FRC or MRC	FJD	FKA or MKA	FKB or MKB
 *Thread Note 5.	 *Thread Note 5.	 *Thread Note 5.	 *Thread Note 5.	 *Thread Note 5.	 *Thread Note 5.	 *Thread Note 5.	 *Thread Note 5.
FTA or MTA	FTB or MTB	FTC or MTC	FTD or MTD	FTG or MTG	FTH or MTH	FTK or MTK	FTL or MTL

SERVICE PARTS (Distribution System)

FLEXIBLE HOSE—Available with 5/32 tube terminals both ends (Type SS), 5/16-24 thread both ends (Type CC), or one of each (Type SC). Measure flexible length between terminals, and order from table below. Specify Name and Part No. Example: "Flexible Hose, B-4863."

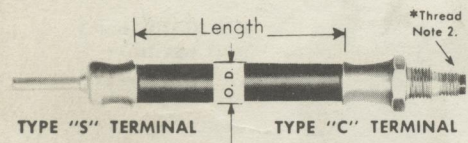

LENGTH (INCHES)	Type SS		Type CC	Type SC
	5/16" O.D.	7/16" O.D.	7/16" O.D.	7/16" O.D.
4	B-4514	—	—	—
5	B-4515	B-2962	B-4873	B-4857
6	B-4516	B-3134	B-4874	B-4858
7	B-4517	B-2963	B-4875	B-4859
8	B-4518	B-3433	B-4876	B-4860
9	B-4519	B-2542	B-4877	B-4861
10	B-4520	B-3145	B-4878	B-4862
12	B-4588	B-3135	B-4879	B-4863
14	B-4589	B-3530	B-4880	B-4864
16	—	B-3531	B-4881	B-4865
18	—	B-3137	B-4882	B-4866
20	—	B-3532	B-4883	B-4867
22	—	B-3528	B-4884	B-4868
24	—	B-3508	B-4885	B-4869
27	—	B-3533	B-4886	B-4870
30	—	B-3534	B-4887	B-4871
33	—	B-3735	B-4888	B-4872





TUBING—Available in 12 foot lengths only. Check outside diameter, material and wall thickness. Order by Name and Part No. Example: "Tubing, 5B25."

MATERIAL	5/32" O.D.				3/32" O.D.	
	Brass	Copper	Copper	Steel	Copper	Steel
WALL	.025	.025	.055	.020	.022	.020
PART NO.	5B25	5C25	5C55	5S20	3C22	3S20

COMPRESSION FITTINGS—Check tubing O.D. and thread and hex on nuts and bushings. See "thread notes" at bottom of page. Sleeves of proper tubing size are required for all connections. Order by Name and Part No. Example: "Bushing, B-3783."

Item	Tube O.D.	Hex	See *Thread Note	Part No.
NUT	5/32	3/8	2	B-1092
	3/32	3/8	3	B-3312
	3/32	5/16	4	B-3610
BUSHING	5/32	3/8	2	B-1371
	5/32	5/16	2	B-3783
SLEEVE	5/32	—	—	B-1061
	3/32	—	—	B-3313

JUNCTIONS — Check number of tapped holes — identify in tables from illustrations and number of mounting holes (untapped). All "One Mounting Hole" types shown. Typical examples of "Two Mounting Holes" types — both "Single" and "Double" are shown. Order by Name and Part No. Example: "Junction, B-3264."

JUNCTION One Mounting Hole				
TYPE	2-Way	3-Way	3-Way	4-Way
PART NO.	B-3288	B-3065	B-1092	B-4231

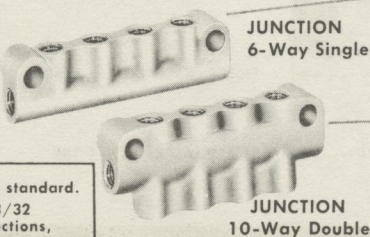

JUNCTION Two Mounting Holes	TYPE	SINGLE	DOUBLE
	4-Way	B-3262	—
5-Way	B-3263	—	
6-Way	B-3264	B-3109	
7-Way	B-3289	—	
8-Way	B-3265	B-3253	
9-Way	B-4508	—	
10-Way	B-3704	B-3254	
12-Way	B-3471	B-3249	
14-Way	—	B-4020	
16-Way	—	B-4025	

***THREAD NOTES**—All unnumbered tapped holes 5/16-24 Bijur standard.

1 5/16-24 for Bijur tapped holes only,	4 1/4-28 for 3/32 tubing connections,
2 5/16-24 for 5/32 tubing connections,	5 1/8 pipe thread.
3 5/16-24 for 3/32 tubing connections,	

BIJUR LUBRICATING CORPORATION • ROCHELLE PARK, NEW JERSEY