



Operating instructions

Universal Lathes



D4000 E



CC-D4000 E

Walter Blombach GmbH
Tool and Machine Factory

Index

EC – Conformity Declaration	4
1. Technical Data	6
2. Drawing and list of parts	7
2.1 Lubricating plan	7
2.2 Arrangement of take-up gears for a 1 mm thread pitch (slope)	8
2.3 Diagram for reading off speed	9
2.4 Position of tumbler gear when cutting LH thread	10
2.5 Position of take-up gears for automatic feed	11
2.6 Operating elements	12
2.7 Headstock with gear and tumbler gear	14
2.7.1 Headstock	14
2.7.2 Gear	14
2.7.3 Tumber gear	14
2.8 Bed with leading spindle drive and take-up gear cutter	16
2.8.1 Bed with leading spindle drive	16
2.8.2 Take-up gear cutter	16
2.9 CNC control drive Z-axis	18
2.10 Tool carriage	20
2.10.1 Saddle apron with cross slide	20
2.10.2 Top slide	21
2.11 CNC control drive X-axis	23
2.12 Headstock	25
2.13 Motor frame	27
3. Circuit diagram	29
4. Delivery and installation	30
5. Conditions for best working results	31
6. Starting-up and maintenance	31
6.1 Maintenance	31
6.2 Starting-up	31
6.3 Lubrication of the machine	32
6.4 Guidelines for the periodical maintenance of the machine	32
7. Safety instructions	32
8. Description of the machine	33
8.1 Labelling	33
9. Description of modules	34
9.1 Structural features	34
9.2 Spindle head	34
9.2.1 Main spindle	34
9.2.2 Electrical parts	35
9.2.3 Change of speed	35

Index

9.2.4	Speed transmission from main spindle to leadscrew	35
9.2.5	Tumbler wheel adjustment	36
9.2.6	Protective cover for chuck	36
9.3	Bed with leadscrew drive	36
9.3.1	Overload coupling	36
9.3.2	Setting the bearing play on the leadscrew	36
9.4	Tooling carriages	37
9.4.1	Cross slide	37
9.4.2	Top slide	37
9.5	Tailstock	38
10.	Applications	39
10.1	Longitudinal and transverse turning	39
10.2	Thread cutting and automatic feed	40
10.2.1	Thread cutting	40
10.2.2	Application of change gears	41
10.2.3	Altering the feeds or thread pitches	42
10.2.4	LH thread	43
11.	Three-jaw chuck and four-jaw chuck	44
12.	Tool holder with conical sleeve	44
13.	Square turret head	45
14.	Unit for lubrication coolant	47
15.	Declaration of noise levels in accordance with DIN EN 24871 (German Industrial Standard)	48
16.	Disposal of the lathe	48

EC – Conformity Declaration

In the name of the manufacturer

Walter Blombach GmbH

**Tool and Machine Factory
based in Remscheid and Neuerburg**

D-42871 Remscheid Postfach 12 01 61 Phone: 0049 (2191) 597-0 Fax: 0049 (2191) 597-40
D-54673 Neuerburg WABECO Str. 1-10 Phone: 0049 (6564) 9697-0 Fax: 0049 (6564) 9697-25

We hereby declare that the universal lathes specified below

**Universal Lathe Typ:
D4000 E
CC-D4000 E**

meet the following regulation requirements for standard serie production

- **directive for machines 98/37 EG**
- **low voltage directive 73/23/EWG**
- **EMV directive 89/336/EWG**

In order to meet / implement the requirements of the above mentioned directives, the following applicable and previously published standards have been adhered to:

EN ISO 12100-1
EN ISO 12100-2
EN 12840
EN 60204-1

D-54673 Neuerburg

City

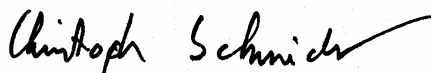

Signature

Outlay

Dear customer!

Congratulations on choosing the **WABECO Universal Lathe**. We have taken great care in its manufacture and we have given it a thorough quality control test. These operating instructions are to help you to work with it safely and properly.

After unpacking the machine please check to see if any kind of damage has occurred during transportation. Any complaints must be made immediately. Complaints made at a later date **cannot** be accepted.

If you have any questions or need any spare parts, please quote the machine number located on the front of the motor).

1. Technical Data

Working range

Centre distance	350 mm
Centre height.....	100 mm
Largest turning diameter over bed.....	200 mm
Largest turning diameter over slide	120 mm

Work spindle

Power	1,4 kW, 230V, 50Hz
Spindle speed infinitely variable	30 – 2300 r.p.m.
Spindle bore	20 mm
Taper in spindle nose	MT3

Cross table

Travel of cross slide	100 mm
Travel of longitudinal slide	50 mm
Swivel range of the upper slide rest.....	360°
max. height of turning tools	16 mm

Guideways

Longitudinal slide.....	Dovetail guide and adjustment rails
Cross slide.....	Dovetail guide and adjustment rails
Chips and dirt stripper	Protection of the guides

Tailstock

Travel of tailstock sleeve	45 mm
Tailstock sleeve taper.....	MT2
Tailstock offset range	
to both sides	± 10 mm

Screw cutting attachment

Automatic feed	0,085 and 0,16 mm/r.p.m.
Thread pitch	
- metric thread	0,4-4,0 mm
- inch thread	10-32 TPI

Noise values according DIN 45635 - part 1

Emission data

No-load running	LpA = 63 dB(A)
Load running	LpA = 67 dB(A)

- Subject to technical alterations -

2. Drawing and list of parts

2.1 Lubricating plan

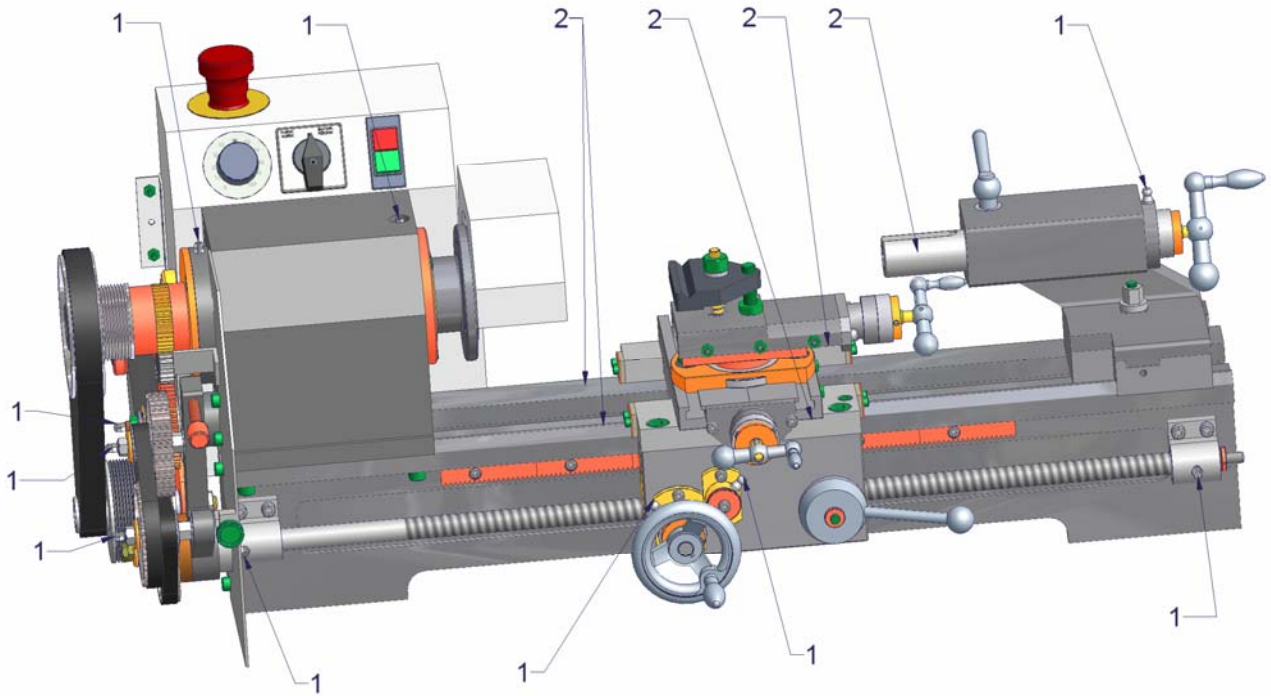

1  all 8 working hours

2  all 8 working hours

2. Drawing and list of parts

2.2 Arrangement of take-up gears for a 1 mm thread pitch (slope) (LH thread)

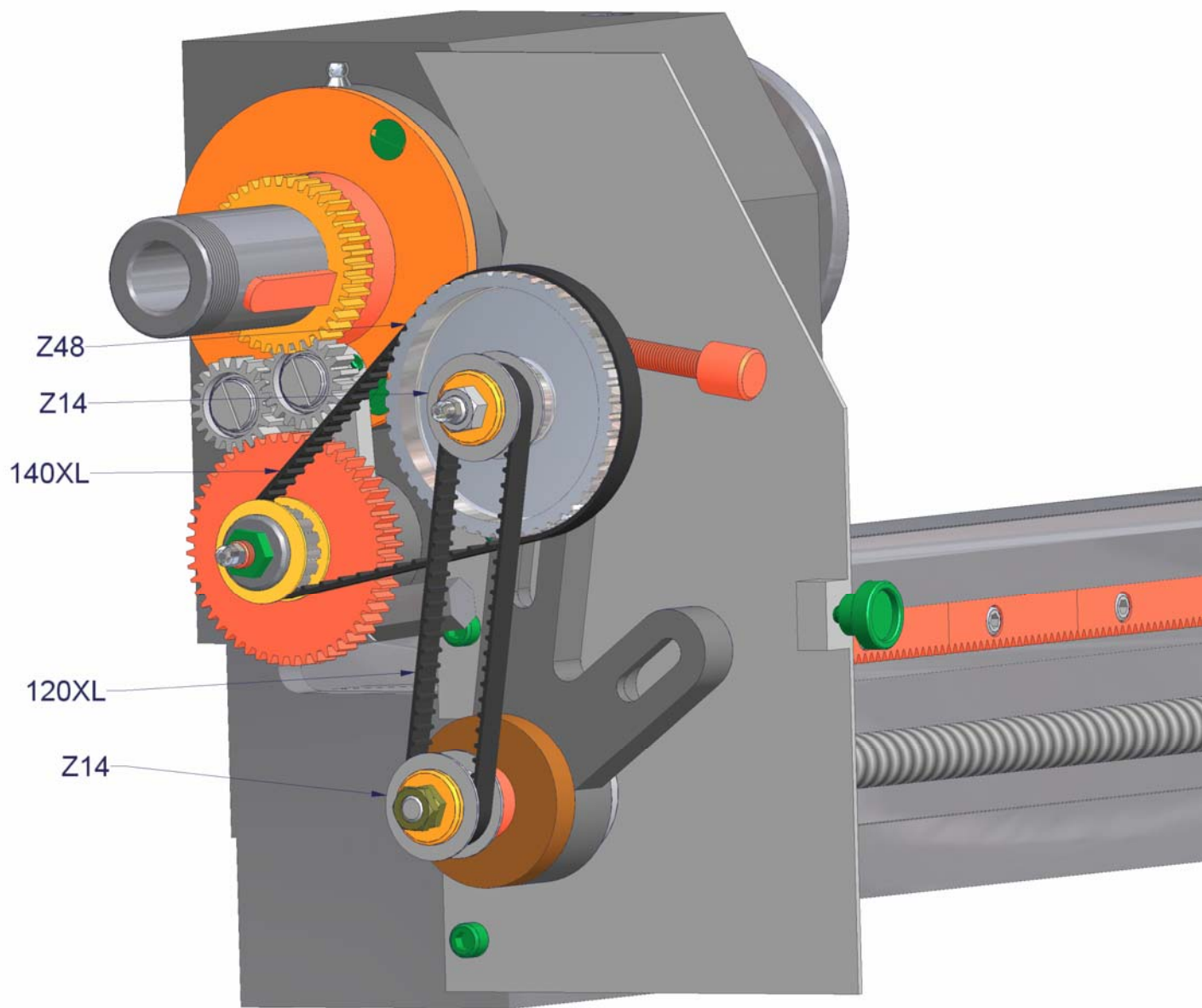

2. Drawing and list of parts

2.3 Diagram for reading off speed

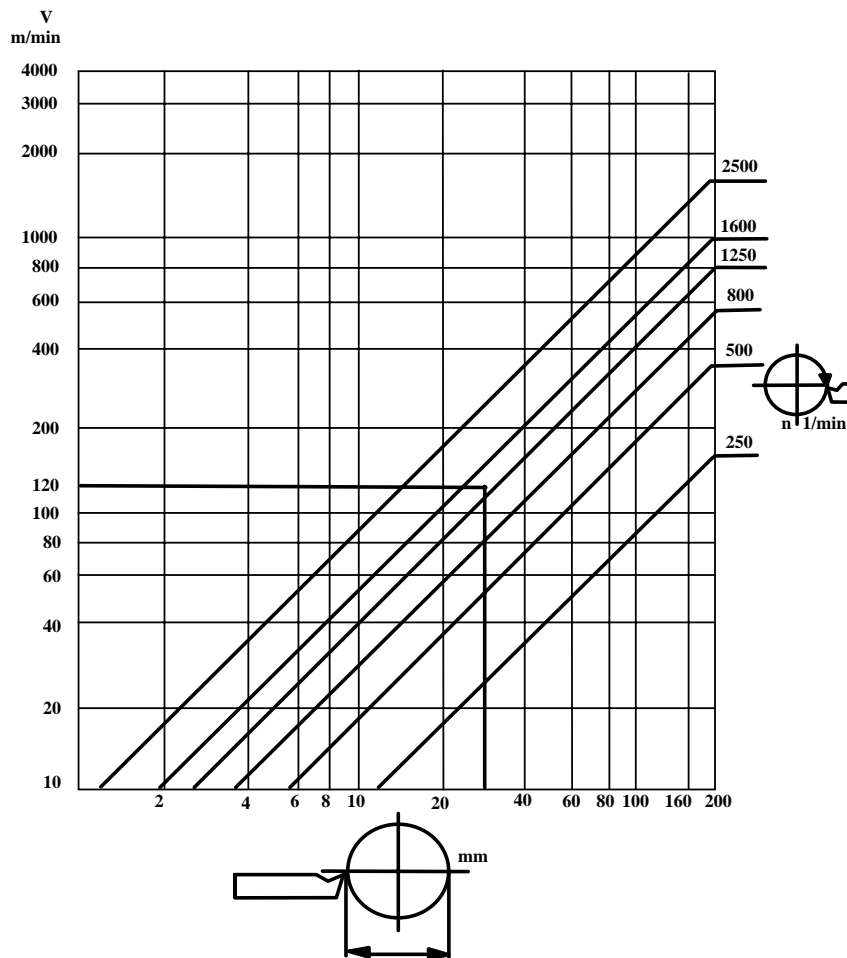
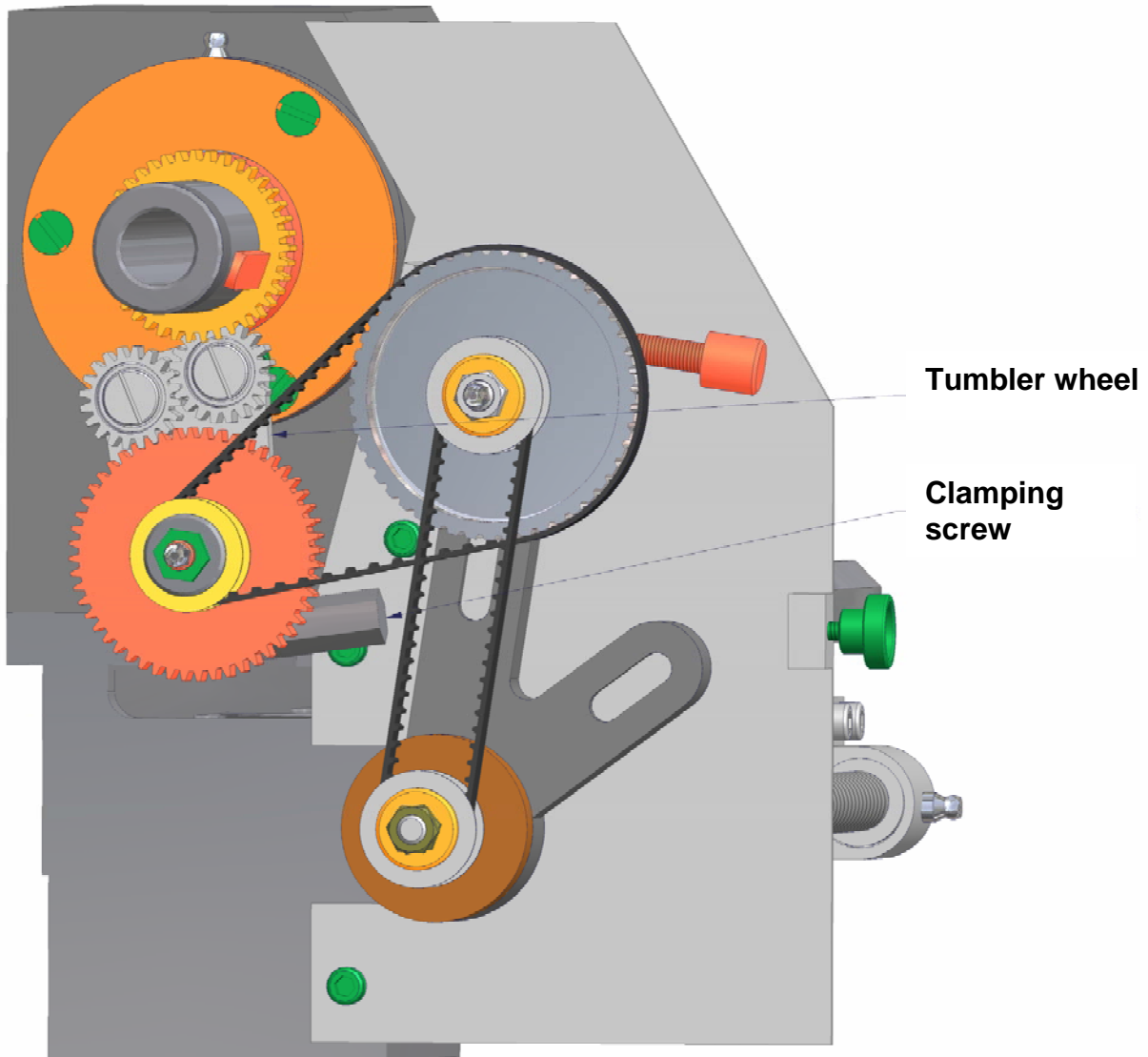

Diagram		
	I	II
0%	75	370
10%	80	380
20%	105	500
30%	170	850
40%	250	1250
50%	300	1500
60%	340	1700
70%	385	1950
80%	440	2200
90%	460	2300
100%	460	2300

2. Drawing and list of parts

2.4 Position of tumbler gear when cutting LH thread



2. Drawing and list of parts

2.5 Position of take-up gears for automatic feed

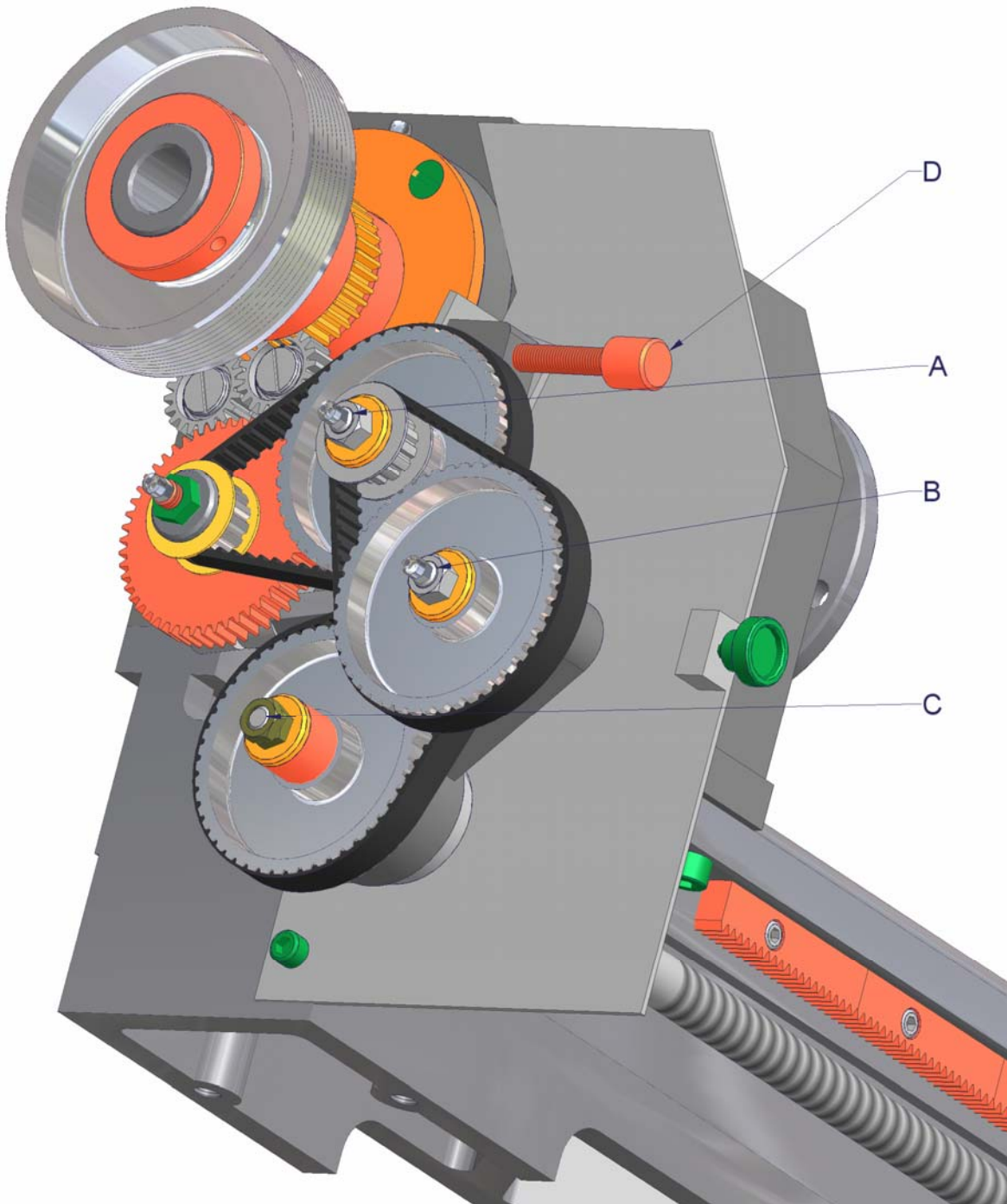

2. Drawing and list of parts

2.6 Operating elements

1. Potentiometer turning knob for choosing the speed of the driving electric motor
2. Emergency OFF switch
3. Reversing switch for changing direction of turn – main spindle
4. Master switch with undervoltage release
5. Opening and closing of clasp nut
6. Chuck handwheel für longitudinal support
7. Clamping lever for tool clamping plate
8. Ball-ended crank for adjusting of cross slide
9. Chuck for quick adjusting of cross slide
10. Clamping screw for clamping of tool carriage
11. Ball-ended crank for adjusting of top slide
12. Chuck handwheel for fastening the centre sleeve of tailstock
13. Clamping lever for fastening the tailstock on guides
14. Ball-ended crank for adjusting the centre sleeve of tailstock

2. Drawing and list of parts

2.6 Operating elements

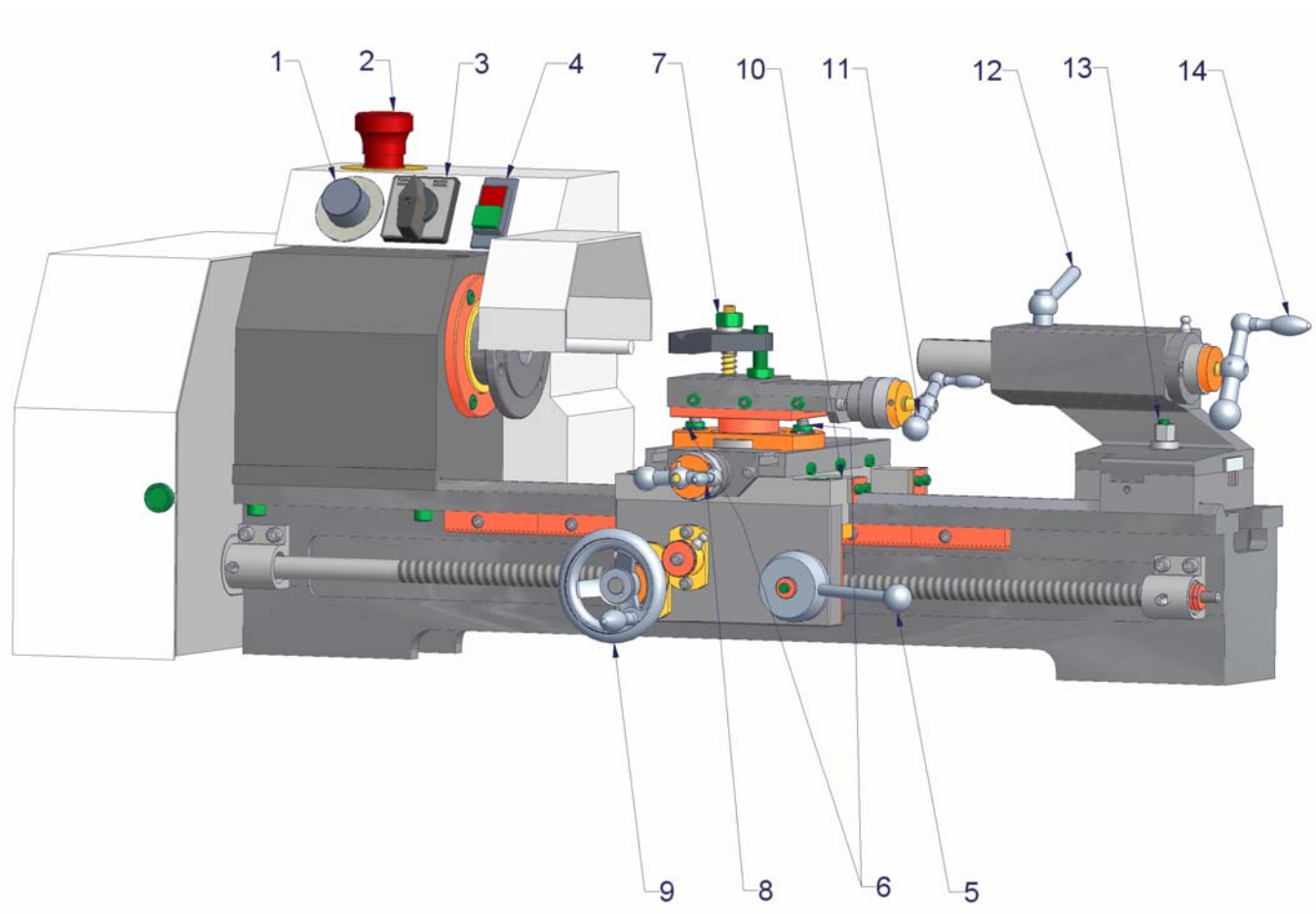

2. Drawing and list of parts

2.7 Headstock with gear and tumbler gear

2.7.1 Headstock

Part-No.	Pcs.	Order-No.	Designation
1	2	10400101	Tapered roller bearing
4	1	10400104	Headstock
5	1	10400105	Flange, front
6	1	10400106	Work spindle
7	1	10400107	Oil wiper ring
8	1	10400108	Feather key
9	1	10400109	Flange, rear
10	2	10400110	Distance ring
11	1	10400111	Belt pulley
12	1	10400112	Belt pulley
13	1	10400113	Adjusting nut
14	3	10400114	Countersunk screw
15	2	11810005	Lubricating nipple
16	7	10400116	Hexagon socket screw
17	1	10400117	Belt short for gear
18	1	10400118	Belt
19	1	10400119	Cover plate
20	1	10400120	Knurled nut
21	1	10400121	Threaded pin
22	2	10400122	Hexagon socket screw

2.7.2 Gear

Part-No.	Pcs.	Order-No.	Designation
23	1	10400123	Belt pulley
24	2	10400124	Ball bearing
25	1	10400125	Bushing
26	1	10400126	Axis
27	1	10400127	Circlip
28	1	10400128	Disc
29	1	10400129	Handle
30	1	10400130	Disc
31	1	10400131	Nut

2.7.3 Tumbler gear

Part-No.	Pcs.	Order-No.	Designation
32	2	10400132	Belt pulley
33	2	10400133	Ball bearing
34	2	10400134	Bolt
35	1	10400135	Handle
36	1	10400136	Clamping bolt
37	1	10400137	Fixing bolt
38	1	10400138	Bushing
39	1	10400139	Feather key
40	1	10400140	Belt pulley Z52
41	1	10400141	Belt pulley Z16
42	2	10400142	Flanged wheel

2. Drawing and list of parts

2.7 Headstock with gear and tumbler gear

43	1	10400143	Disc
44	1	11700053	Nut
45	1	11810009	Lubricating nipples
46	2	11700077	Headless pin

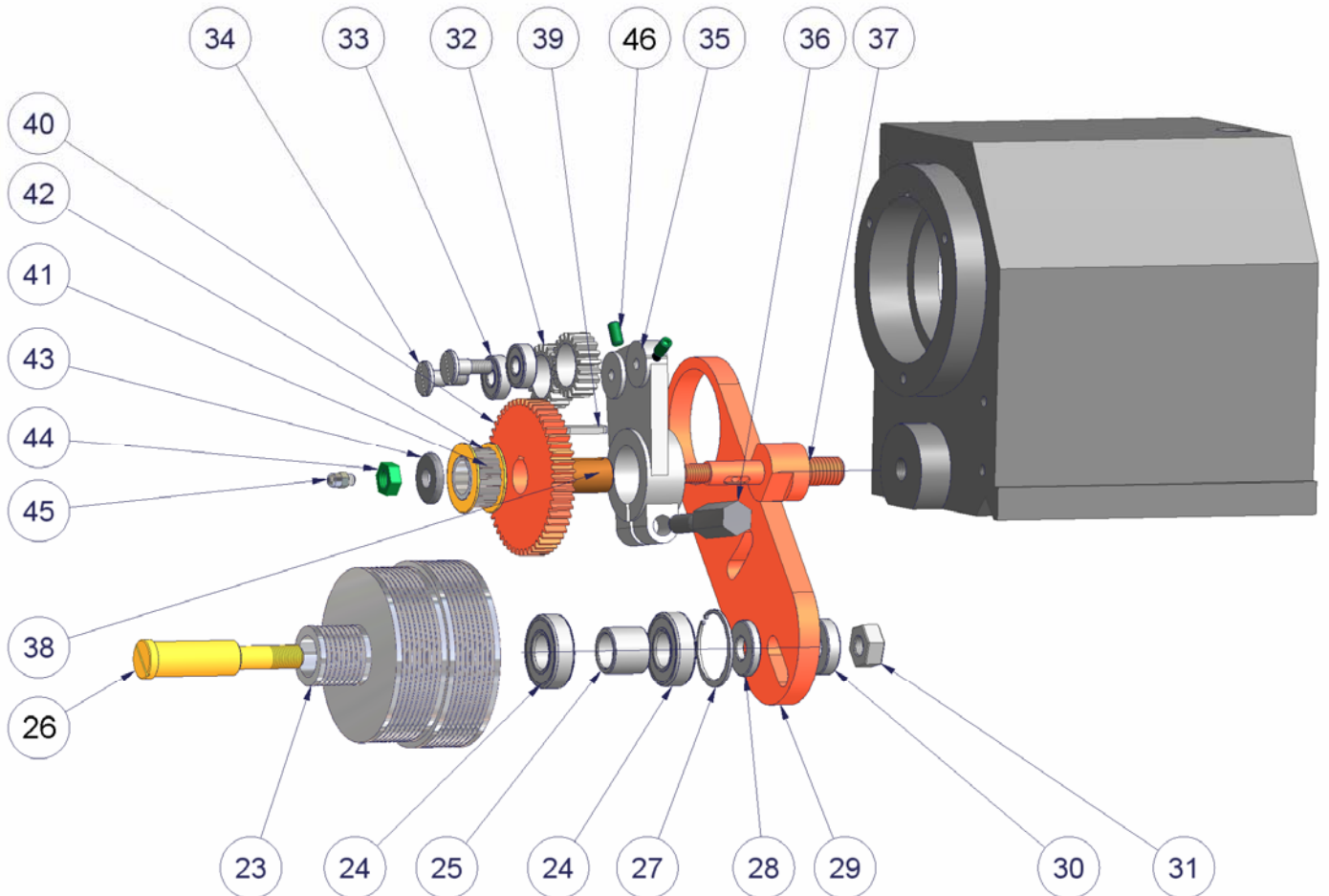
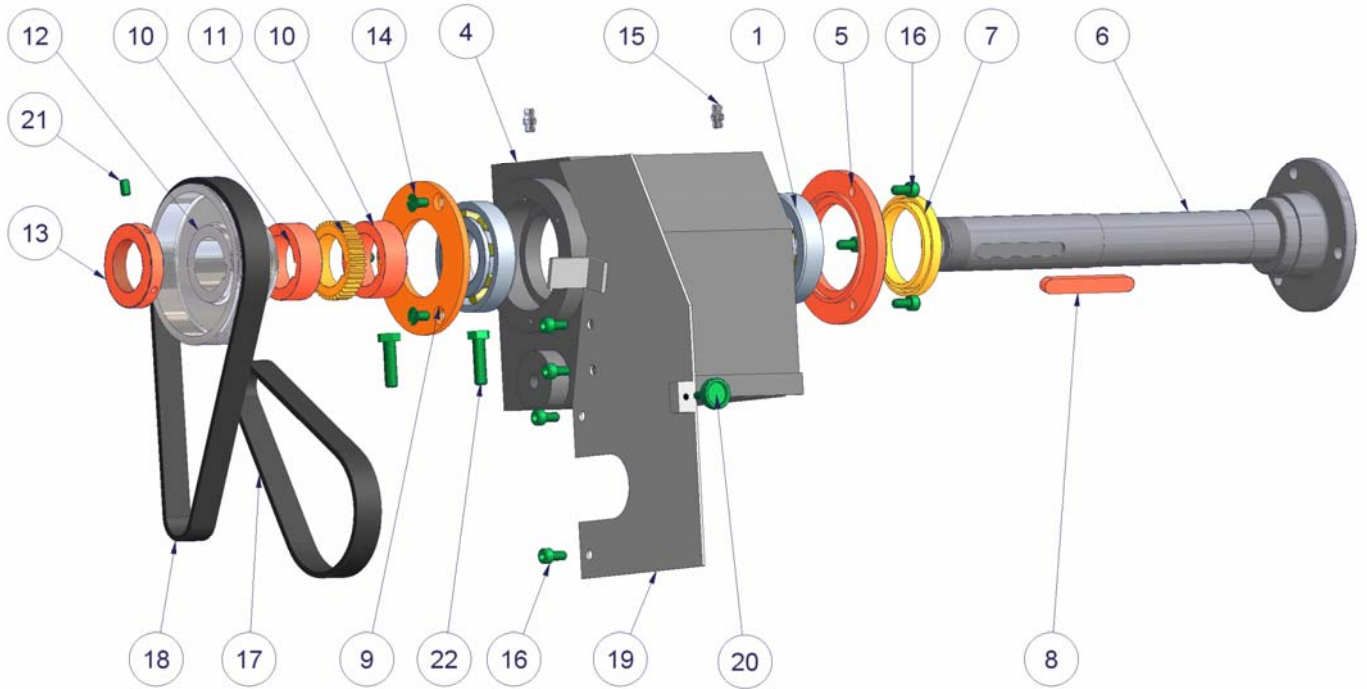

2.8 Bed with leading spindle drive and change gear quadrant

2.8.1 Bed with leading spindle drive

Part-No.	Pcs.	Order-No.	Designation
1	1	10400201	Toothed racket
3	1	10400203	Bed
4	1	10400204	Supporting bearing, front
5	1	10400205	Bushing
6	1	10400206	Leading spindle
7	1	10400207	Supporting bearing, rear
8	2	10400208	Thrust block, loose
10	1	10400210	Bushing
11	4	10400211	Hexagon socket screw
12	6	10400212	Hexagon socket screw
13	2	11810005	Lubricating nipple
14	2	10400214	Nut
17	1	10400217	Disc
18	2	10400218	Nut
19	2	10400219	Hexagon socket screw

2.8.2 Take-up gear cutter

Part-No.	Pcs.	Order-No.	Designation
1	1	10400301	Take-up gear cutter
2	1	10400302	Shearing bushing
3	1	10400303	Feather key of shearing bushing
4	3	10400304	Belt pulley Z48
5	1	10400305	Bushing
6	2	10400306	Disc
7	2	10400307	Disc
8	1	10400308	Take-up gear bolt
9	2	10400309	Bushing
10	2	10400310	Feather key for bushing
11	2	10400311	Toothed belt
12	2	10400312	Toothed belt pulley Z14
13	1	10400313	Take-up gear bolt
14	2	10400314	Disc
15	2	11700053	Nut
16	2	11810009	Lubricating nipple
17	2	11700054	Square nut

2. Drawing and list of parts

2.8 Bed with leading spindle drive and take-up gear cutter

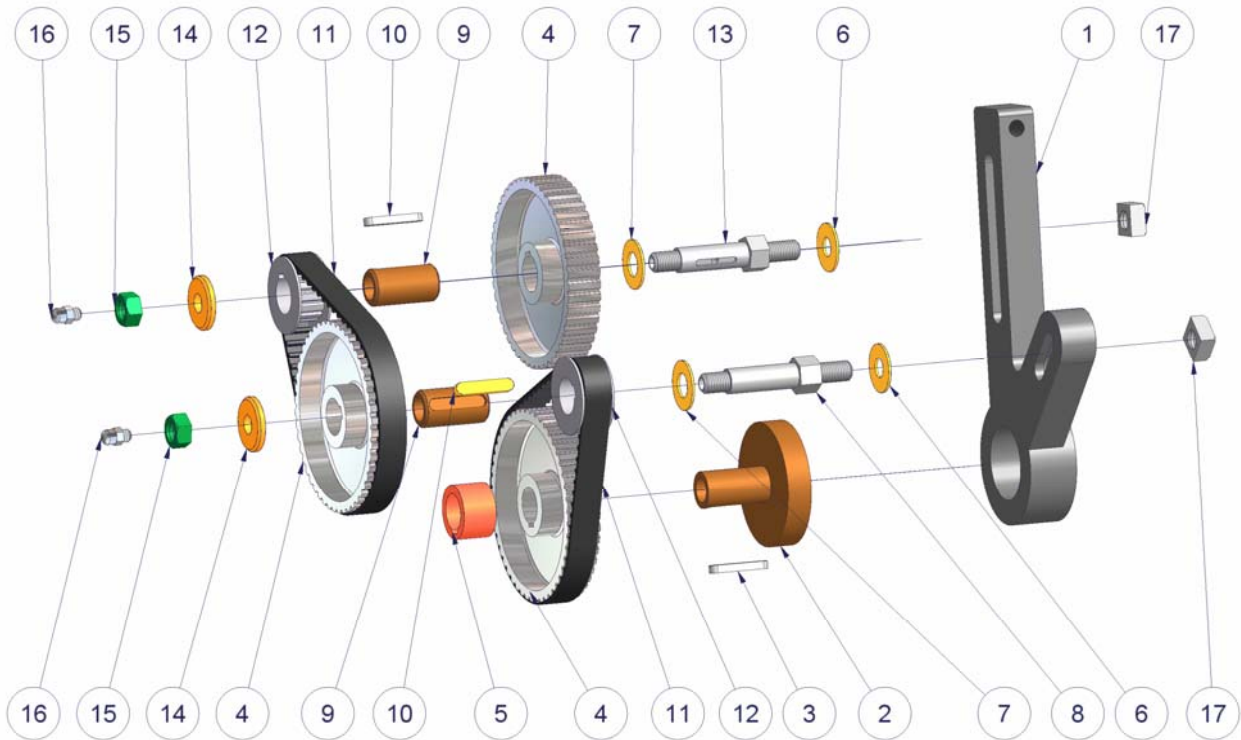
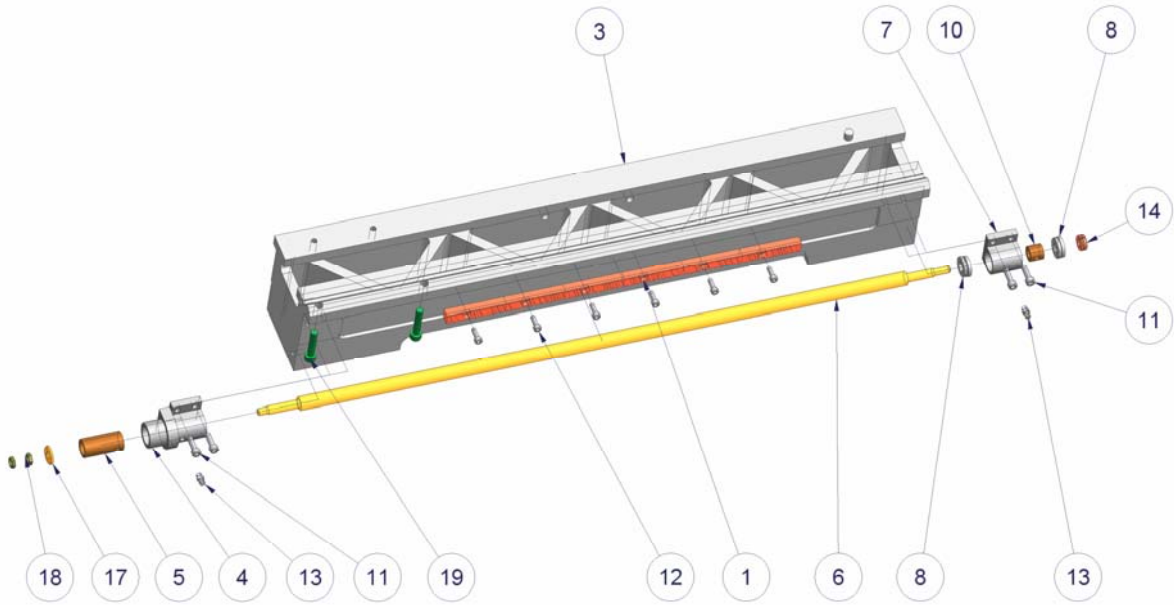

2. Drawing and list of parts

2.9 CNC control drive Z-axis

Part-No.	Pcs.	Order-No.	Designation
32	1		Belt pulley Z30
33	1		Threaded pin
34	1		Motor sheet metal
35	2		Earthing screw
37	1		Motor housing
38	1		Step motor
39	4		Washer
40	4		Earthing screw
41	4		Hexagon nut
42	1		Lid for motor housing
43	4		Earthing screw
44	1		Belt pulley Z12
45	1		Zylindrical pin
46	2		Washer for tooth wheel
47	2		Circlip
48	1		Toothed belt
49	1		Protective cover
50	2		Nut

2. Drawing and list of parts

2.9 CNC control drive Z-axis

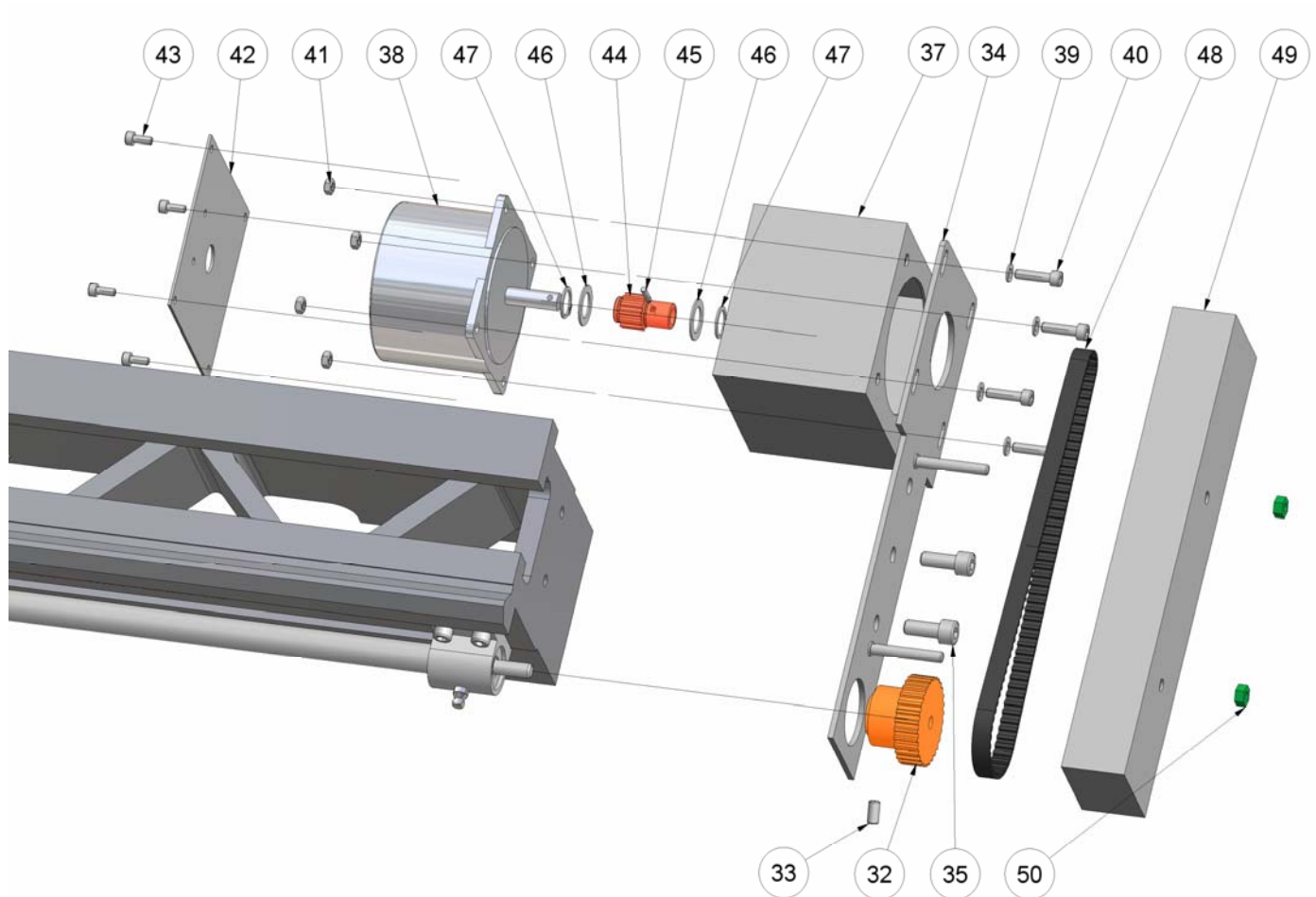

2. Drawing and list of parts

2.10 Tool carriage

2.10.1 Saddle apron with cross slide

Part-No.	Pcs.	Order-No.	Designation
1	1	10400401	Lower part of cross slide
2	1	10400402	Nut
3	1	10400403	Disc
4	1	10400404	Hexagon bolt
5	1	10400405	Upper part of cross slide
6	1	10400406	Adjustment rail
7	2	10400407	Felt
8	2	10400408	Felt
9	2	10400409	Felt clamp
10	2	10400410	Felt clamp
11	14	10400411	Hexagonal socket bolt
12	6	10400412	Hexagon bolt
13	1	10400413	Saddle apron
14	2	10400414	Hexagonal socket bolt
15	1	10400415	Cleap holder
16	2	10400416	Clasp nut
17	2	10400417	Pin
18	2	10400417	Guide rail
19	1	10400419	Feather key clasp holder
20	1	10400420	Switch lever
21	1	10400421	Disc
22	1	10400422	Flange
23	1	10400423	Liner
24	2	11810005	Lubricating nipple
25	9	10400425	Hexagonal socket bolt
26	1	10400426	Pinion
27	2	10400427	Scale support
28	4	10400428	Thrust piece scale support
29	4	10400429	Threaded pin
30	1	10400430	Hand wheel
31	2	10400431	Pin
32	2	11810004	Ball
33	2	10400433	Scale ring
34	1	10400434	Flange
35	1	10400435	Liner
36	1	10400436	Take-up gear
37	1	10400437	Disc
38	1	10400438	Clamping piece
39	1	10400439	Hexagonal socket bolt
40	1	10400440	Guide piece
41	4	10400441	Hexagonal socket bolt
45	3	11700055	Threaded pin
46	1	10400446	Guide rail
47	1	10400447	Guide rail
48	3	10400448	Threaded pin

2. Drawing and list of parts

2.10 Tool carriage

2.10.1 Saddle apron with cross slide

Part-No.	Pcs.	Order-No.	Designation
52	1	10400452	Washer
53	2	11850002	Feather
54	1	10400454	Spindle bearing
55	2	10400455	Deep groove ball bearing
56	1	10400456	Spindle square
57	1	10400457	Ball-ended crank

2.10.2 Top slide

Part-No.	Pcs.	Order-No.	Designation
1	1	10400501	Top slide lower part
2	1	10400502	Guide ring
3	1	10400503	Pin
4	6	10400504	Hexagonal socket screw
5	1	10400505	Clamping piece
6	1	10400506	Nut
7	1	10400507	Top slide upper part
8	1	10400508	Adjustment rail
9	1	10400509	Thread bolt
10	3	11700056	Threaded pin
11	3	10400511	Nut
12	1	10400512	Pin
13	1	10400513	Clamping claw
14	1	10400514	Thrust disc clamping claw
15	1	10400515	High nut
16	1	10400516	Hexagonal socket screw
17	1	10400517	Disc
18	1	10400518	Hexagonal nut
19	1	10400519	Saddle
20	2	10400520	Deep groove ball bearing
21	1	10400521	Spindle
22	1	11810004	Ball
23	1	10400523	Pin
24	1	10400524	Ball-ended crank
25	3	10400525	Thrust piece scale support
26	3	10400526	Threaded pin
27	1	10400527	Scale support
28	1	10400528	Scale ring
29	1	11850002	Feather
30	1	10400530	Feather

2. Drawing and list of parts

2.10 Tool carriage

Cross slide

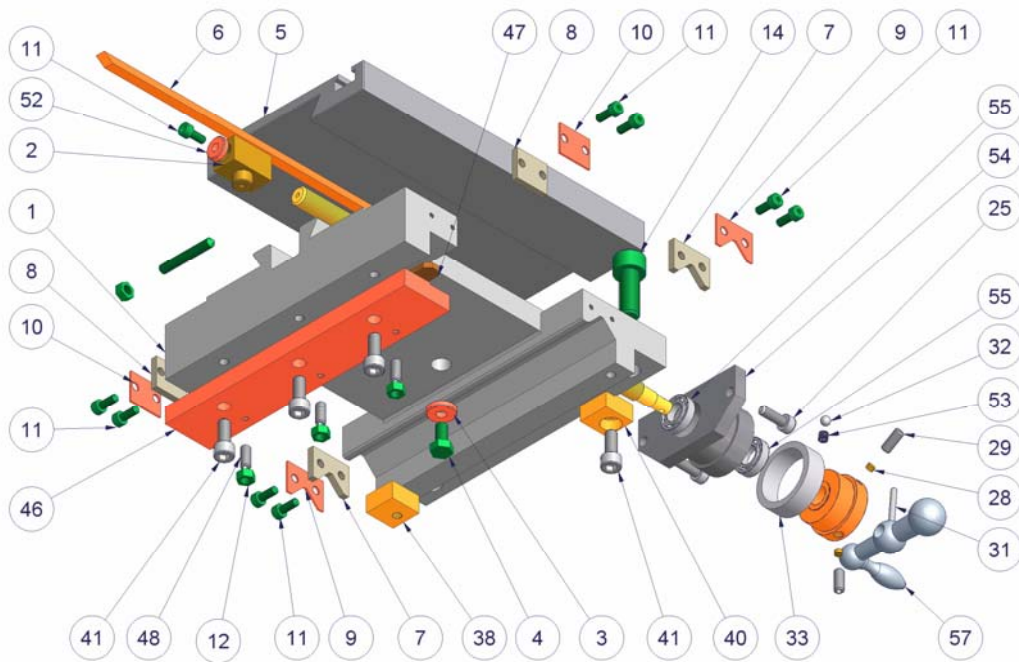
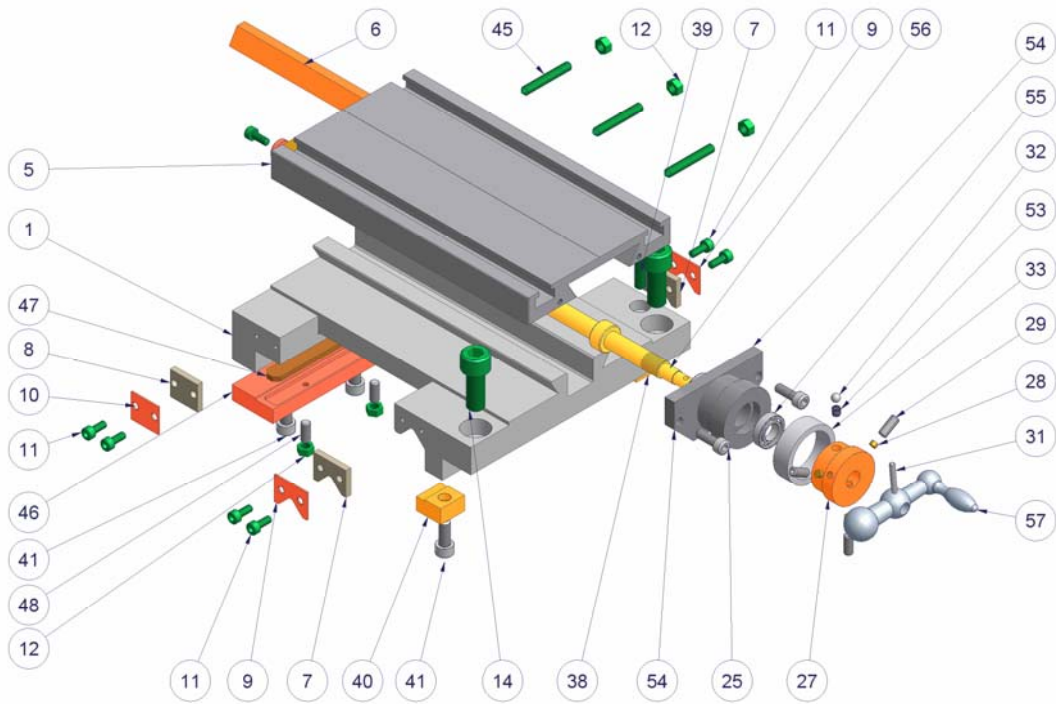

2. Drawing and list of parts

2.10 Tool carriage

Saddle apron

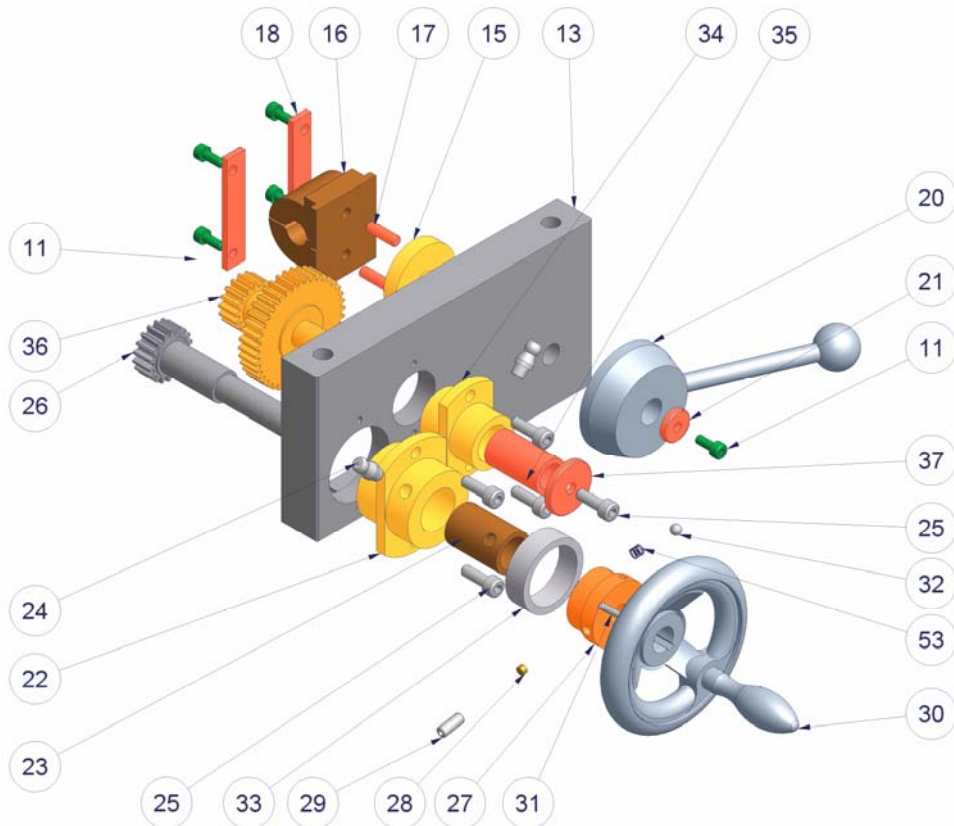

Top slide

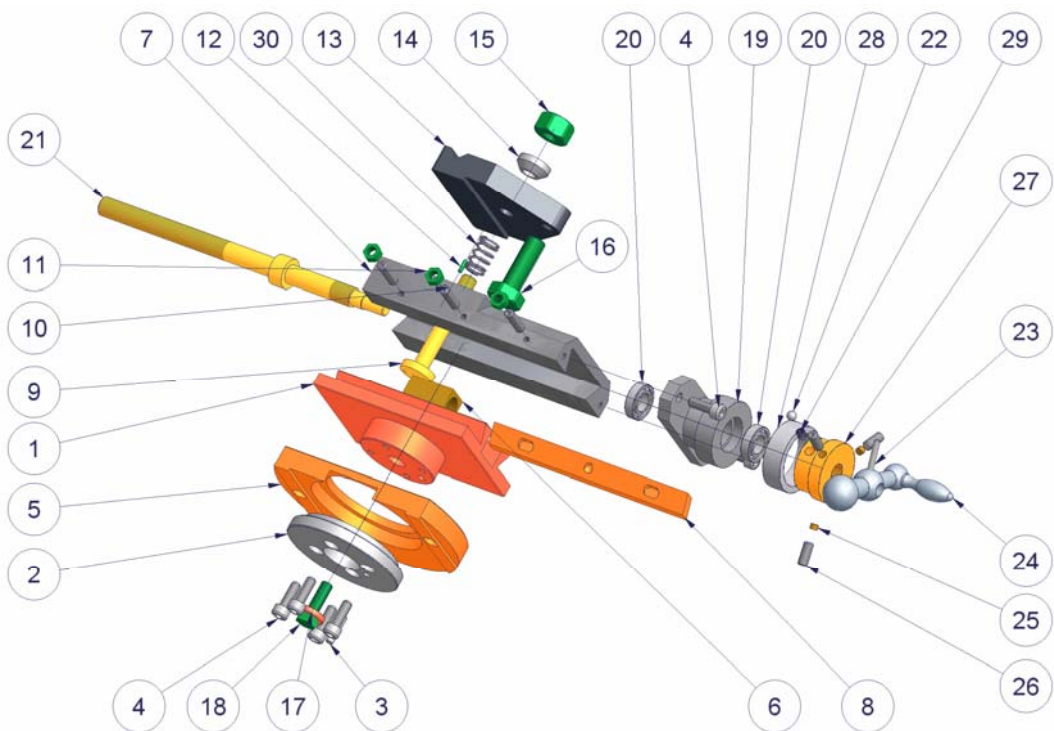

2. Drawing and list of parts

2.11 CNC control drive X-axis

Part-No.	Pcs.	Order-No.	Designation
13	1		Feather
14	1		Ball
15	1		Zylindrical pin
16	1		Ball-ended crank
20	1		Scale ring
39	4		Earthing screw
76	1		Belt pulley
77	3		Threaded pin
78	1		Motor mechanism plate
79	1		Clamping plate
80	4		Auxiliary motor
81	1		Step motor
82	4		Saucer-head screw
83	4		Washer
84	1		Belt pulley
85	2		Flanged wheel
86	1		Threaded pin
87	4		Hexagon nut
88	1		Toothed belt
89	1		Protection cab
90	2		Earthing screw

2. Drawing and list of parts

2.11 CNC control drive X-axis

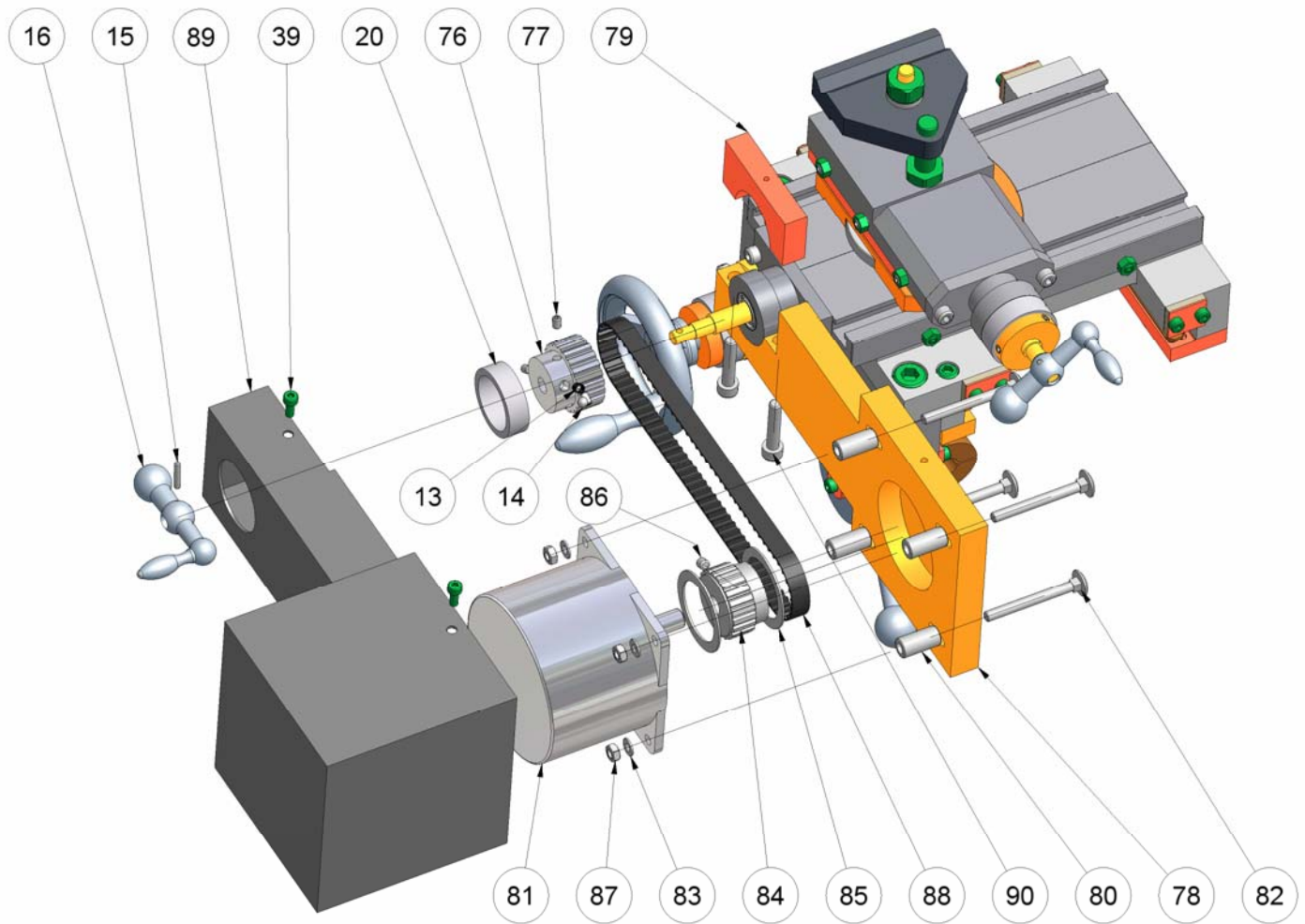

2. Drawing and list of parts

2.12 Tailstock

Part-No.	Pcs.	Order-No.	Designation
1	1	10400601	Tailstock
2	1	10400602	Upper part of shim
3	1	10400603	Lower part of shim
4	1	10400604	Quill
5	1	10400605	Scale
6	1	10400606	Threaded pin
7	1	10400607	Ball-ended crank
8	1	10400608	Lower part of tailstock
9	2	10400609	Threaded pin
10	1	10400610	Shim
11	1	10400611	Hexagon bolt
12	1	10400612	Washer
13	1	10400613	Hexagon nut
14	1	10400614	Scale, short
15	1	10400615	Spindle
16	1	10400616	Flange
17	1	11810005	Lubricating nipple
18	2	10400618	Hexagon socket screw
19	1	11850002	Feather
20	1	11810004	Ball
21	1	10400621	Threaded pin
22	1	10400622	Pressure spring
23	1	10400623	Scale support
24	1	10400624	Scale ring
25	1	10400625	Ball-ended crank
26	1	10400626	Pin

2. Drawing and list of parts

2.12 Tailstock

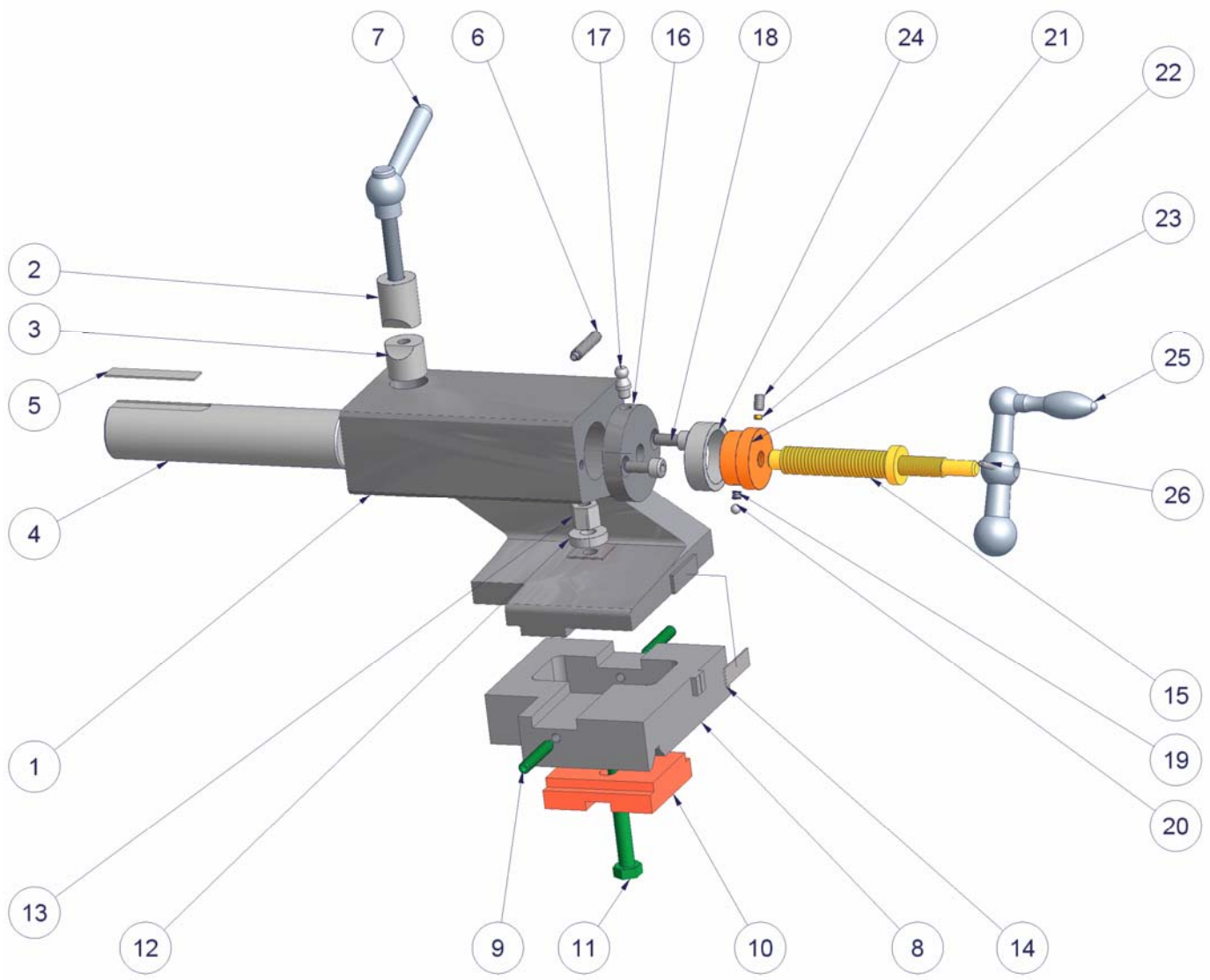

2. Drawing and list of parts

2.13 Motor frame

Part-No.	Pcs.	Order-No.	Designation
1	1	11800001	Master switch
2	1	11800008	Emergency OFF switch
3	1	11800014	Final switch
4	1	11800005	Bottom plate
5	1	10400705	Motor
6	1	10400706	Motor frame
7	1	10400707	Platina holder
8	2	11700057	Earthing screw
9	1	10400709	Base plate
11	1	11800004	Potentiometer complete
16	12	11700002	Nut
20	2	10400720	Guide rail
21	4	11700057	Cylinder bolt
22	1	10400722	Eccentric ring
23	1	10400723	Set collar
24	1	10400724	Protection cab, chuck
25	1	11700013	Hexagon socket screw
26	2	11700051	Countersunk heard screw
28	1	10400728	Covering motor frame
29	4	11700026	Hexagon socket screw
30	4	11700059	Hexagon socket screw
31	1	10400731	Protection cab
32	4	11700026	Hexagon socket screw
33	1	11700060	Washer
34	1	11700061	Hexagon socket screw

2. Drawing and list of parts

2.13 Motor frame

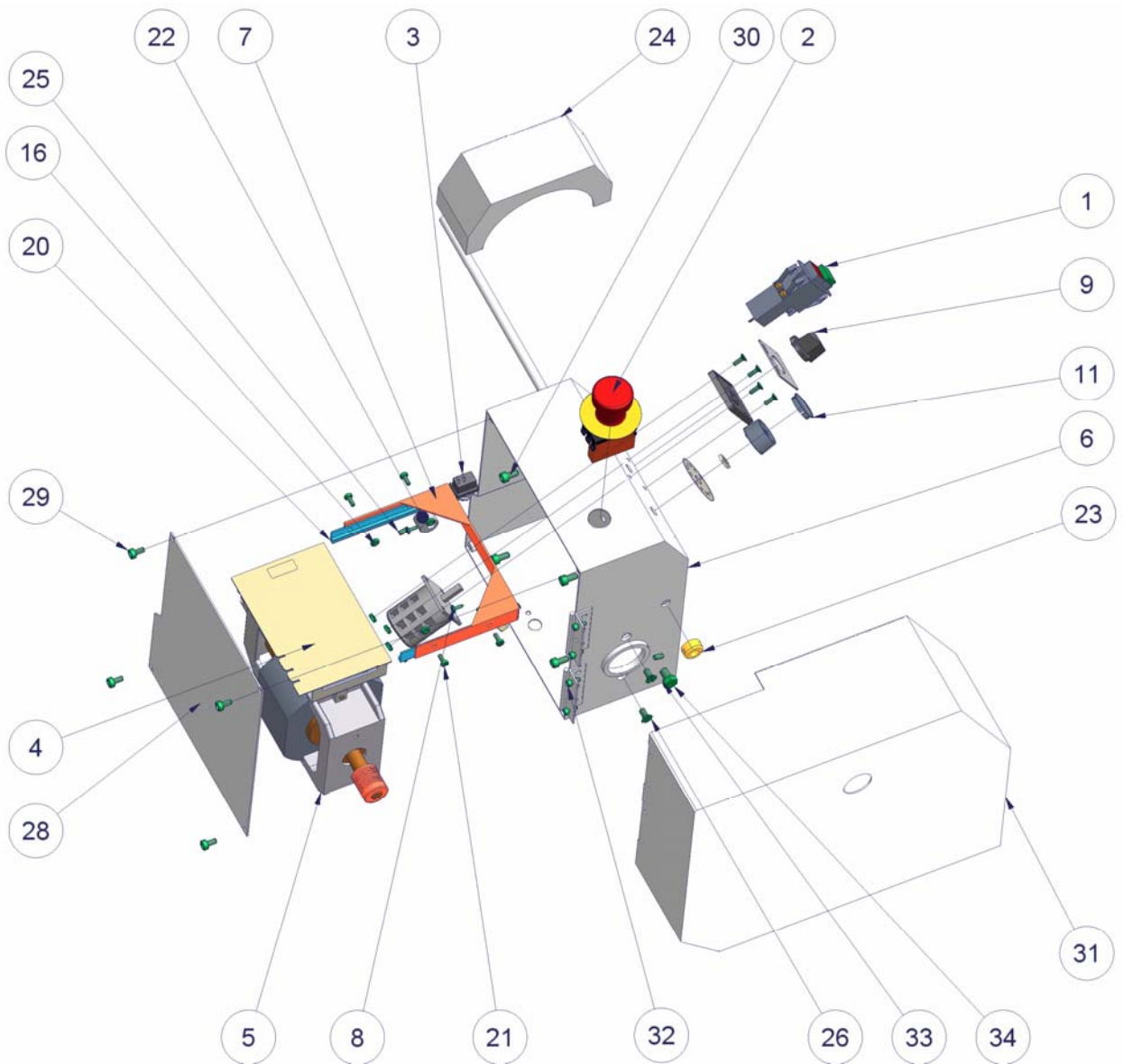

3. Circuit diagram

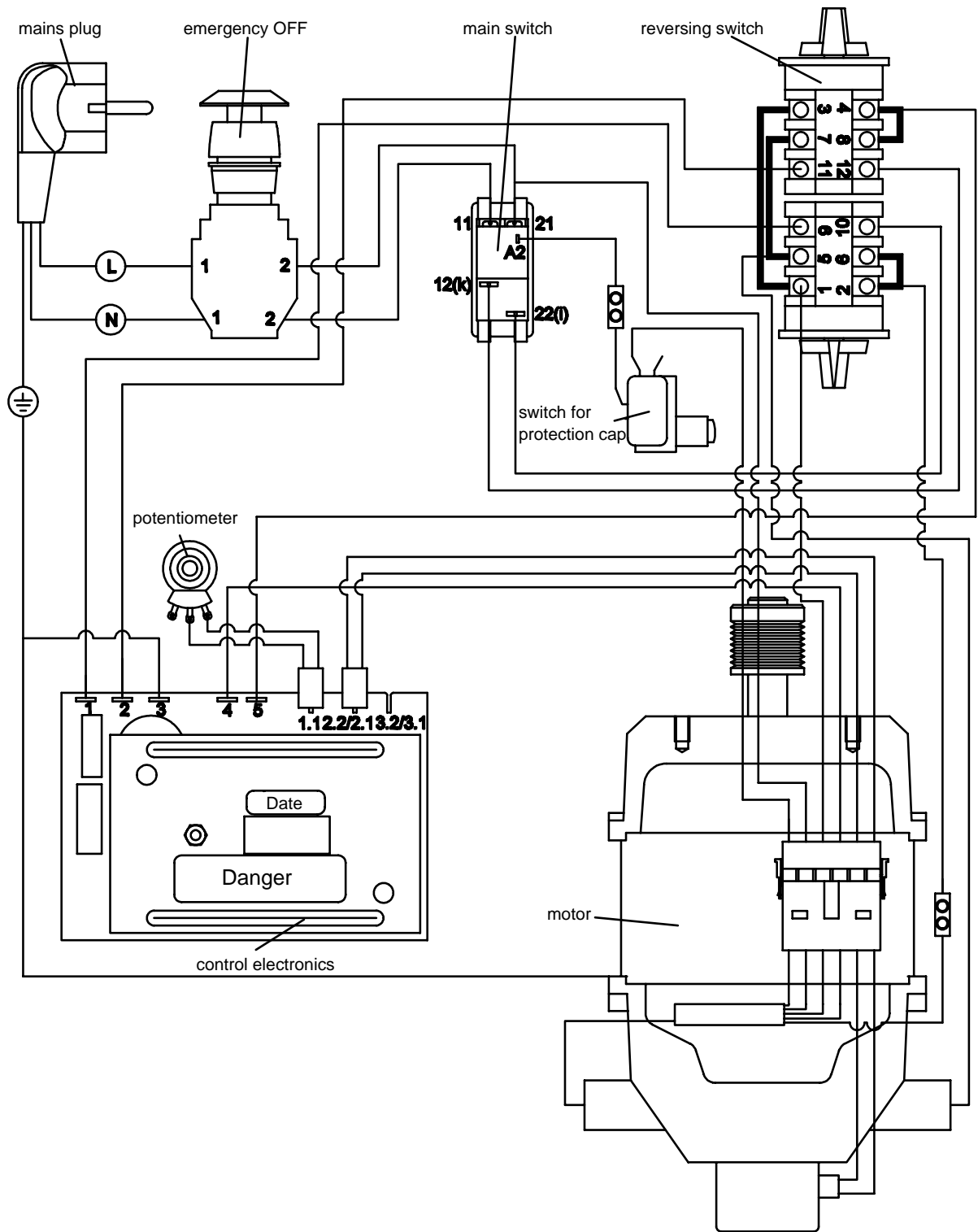

4. Delivery and installation

The lathes are carefully packed in our factory.

Please check the following on delivery:

- 1. whether the packaging has been damaged and/or:**
- 2. whether the drilling and milling machine shows signs of transport damage or if there are grounds for complaint. In this case we request your immediate notification. Claims made at a later date cannot be acknowledged.**

The lathes must be installed on an appropriate, level and firm base.

This would be, for example:

- a base cabinet such as in our accessories programme
- own work bench as long as it is strong enough to carry the weight of the machine without warping (see technical data and check with spirit level) and has an even surface.
- a steel plate

The lathe must be firmly screwed down onto the base. To facilitate this, there are 9 mm holes in the machine base. Good results and a minimum of vibration during operation can only be guaranteed if the above mentioned requirements for secure mounting have been kept to.

The installation of the machine should take place where there is sufficient lighting, electrical cables with earthed sockets and O-conductors are installed adequately near to the machine so that the mains connection lead is not subject to any tension whatsoever. The mains lead should be such that, by means of a multiple socket, a coolant or lubrication unit can also be connected.

5. Conditions for best working results



- Fix the machine on a sturdy, level support.
- Use sharp processing tools.
- Adjust speed setting and feed to fit the material and diameter of the tool
- Clamp the tools so that the clamping position is as near possible to the work-piece.
- Clamp the workpieces fast and without vibrations.
- Long pcs. support with tailstock or with fixed stay.
- Apply coolant and lubricant for better surface quality (finish) and dimensional accuracy.
- Fix processing tools and workpieces on clean clamping surfaces.
- Grease the machine sufficiently.
- Use the correct tools for removing the material from the workpieces.
- Set correct bearing clearances and align guides early enough.

6. Starting-up and maintenance

6.1 Maintenance

The longtime serviceability is vitally dependent upon a corresponding serving attendance. The lathe needs to be cleaned after every turning job.



- In case the lathe is being erected within a moist cellar, all naked parts need to be oiled after completed usage to avoid corrosion.
- An overall and constant lubrication of all moving parts is highly significant.
- In case backlash within the bearings or within the guideways of the slides should occur, readjust in time to avoid the bearing or the guideways of the slides being destroyed.

6.2 Starting-up



- Before starting up the machine please clean it thoroughly and lubricate all lubricating points with grease. Oil the cross support, leadscrews, guiding rods and tailstock barrel well.
- Check all spindles manually to make sure they move smoothly.
- Run the lathe on the lowest speed. Do not run the machine on full load at first.

Please pay particular attention before you start up the machine:

1. Check to make sure the machine is free from protective agent (preservative) and that all sliding areas are clean and oiled. We recommend the use of petroleum or similar to remove the protective agent.
2. Lubricate the machine according to the lubricating instructions.
3. Release the clamp from the longitudinal saddle and check the slide displacement manually for both axes.
4. Check to make sure the protective hoods are closed.
5. Check the condition of the chuck.

6. Starting-up and maintenance

6.3 Lubrication of the machine

The lathe should be lubricated every 8 operating hours according to the lubricating schedule (2.1).

Lubricating points 3 (bed guide), 4 (dove-tail guide cross slide), 5 (dove-tail guide top slide) and 7 (tailstock barrel) with the help of an oil can and a standard lubricating oil, moving the saddle and the barrel backwards and forwards while doing so.

All other lubricating points are lubricated at the designated lubricating nipples with a grease gun and standard roller bearing grease.

6.4 Guidelines for the periodical maintenance of the machine

Daily (every 8 operating hours)	The lubricating points in compliance with lubricating schedule 2.1 Clean the machine and guides.
Every 3 months (every 500-600 operating hours)	Check the tension of the Poly-V and pulley and tighten as necessary. Check the play in the guideways and leadscrews and adjust. Check the bearing heat in the main spindle and electric motor.

7. Safety instructions

1. The feed line for the motor may only be connected to a shock-proof socket or junction box. (Have the socket or junction box checked by an electrician beforehand; protection against children being able to put into operation).
2. The socket or junction box must be close enough to the equipment, that the current-carrying cable is subjected to no tensile strain whatsoever.
3. When maintenance or cleaning work is being done, the machine must be shutdown and the mains plug pulled out.
4. Do not brake workpieces or chuck by hand or any other objects.
5. Wear safety goggles when working the machine.
6. Do not remove the chips with the hand. Use corresponding aids (hand brush, hook, paint brush).
7. Always keep the protective hood on the driving mechanism closed.
8. The turning tools must be firmly tightened at the correct height and as short as possible.
9. The turning tools must never be exchanged when the machine is running.
10. **Never leave the clamping chuck key in (even when not in operation).**
11. Observe the bearing distance of the turning chuck. (turning jaws max. 40mm Ø, drilling jaws max. 100mm Ø).
12. **Never take measurements on workpieces being turned** (danger of accidents and damage to the measuring gauges).

7. Safety instructions

13. Do not wear loose items of clothing (ties, shirt sleeves, jewellery etc.).
14. When working between centres, always centre well in order to avoid a flying-out of the work-piece. In addition, check the tightening screw of the tailstock to make sure it is tight.
15. When working with automatic advance take care that the cross table does not touch the chuck or the tailstock.
16. Never leave the machine when in operation.
17. **When turning wood, use the lathe centre for the slaving of the work piece instead of the lathe chuck.**
18. The machine must be secured so that it cannot be switched on by children. Make sure that other people do not come in contact with the machine.
19. The machine must be kept dry at all times.
20. Check the machine frequently for damage. Any damage parts must be replaced with original parts and should be fitted by an expert or by us.

8. Description of the machine

To make sure the machine runs properly and in order to have maximum protection from damage it is necessary for the operator to get to know how the machine works very thoroughly. Please read the following instructions very carefully before starting up the machine.

8.1 Labelling

On the front of the protective hood you will find tables for the individual feeds and pitches with the combinations of take-up gears.

The take-up gears for other feeds and pitches are situated in the accompanying gear set for metric and inch threads.

In chapter 9.3 we have shown graphically the relationship of the cutting speed of the workpiece diameter and the machine speed. Given a certain workpiece diameter and a certain cutting speed then it is relatively easy to determine the correct speed of the main spindle, e.g. $d = 30\text{mm}$, $v = 120\text{ m/min}$ you can conclude that $n = 1250\text{ min}^{-1}$.

9. Description of modules

9.1 Structural features

- Massive large-dimensioned grey cast iron machine bed.
- Sturdy cross ribbing makes the bed extremely stable and enables you to work with no oscillations.
- The wide prismatic guide is ground.
- Cross and longitudinal support with dove-tail guides and adjusting rails.
- A stripper for chips and dirt on all guides.
- Large-dimensioned, pivoting scale rings 0.05 mm exactness.
- Main spindle sited in adjustable tapered roller bearings.
- Ground main spindle nose.
- Electronic infinitely-adjustable spindle speeds.
- Manageable ergonomically-arranged controls.
- Equipped with Emergency Off tracer.
- Main switch with undervoltage release.
- Motor switchable left-right.
- Tailstock with its own prismatic guides.
- Large torque on main spindle via gear reducing units.

9.2 Spindle head

9.2.1 Main spindle

The spindle head is firmly attached to the slide bars. In the spindle head, the work spindle is run on two adjustable precision tapered roller bearings.

Should a readjustment of the bearings be necessary, please proceed in the following manner:

1. Loosen the locking screw in the adjustment nut. The adjustment nut is located at the rear end of the work spindle.
2. Turn the adjustment nut in a clockwise direction until the bearings again run free of play (the work spindle being easily able to be turned by hand).
3. Tighten the locking screw again.

Roller bearing adjusted too tightly become useless after a short period.

The spindle throat (capacity) is 20 mm.

For safety reasons the whole drive is completely covered with a protective hood and is fixed on to the headstock.

9. Description of modules

9.2.2 Electrical parts

All the electrical equipment is housed in the box situated at the rear side of the headstock.

The AC motor is supplied already installed. The shock-proof plug can be connected directly via a shock-proof socket to the 220 V mains supply.

All 230V machines are fitted with a master switch with undervoltage release, i.e. this switch must be switched on before the machine can be switched on via the reserving switch. The master switch must also be switched on again following a power failure.

If you wish to change the direction of turn of the motor with a reversing switch then in the case of Electronic Lathe 10600 the reversing switch must remain in the O position for about one second so that the relay on the control platina has enough time to switch over.

Before connecting the machine to the mains supply you must check the earth.

9.2.3 Change of speed

The rotational speed of the work spindle can be infiniely varied between 45 and 2.300 rpm using the potentiometer on the front of the machine.

The drive belt must be relocated if the lower speed stage with a minimum speed of 45 rpm is required.

Please proceed as follows (see headstock):

Remove the protective hood and slacken the drive belts. To do this, slacken nut and screw. Turn back toothed belt pulley (23) so that drive belt can be let down with no problem on to the different wheel transmission (12 and 23).

To tighten the belts, tighten toothed belt pulley (53) until the belts on the discs do not slip.

Tighten nut (26) again.

9.2.4 Speed transmission from main spindle to leadscrew

The gearwheel (11) on the main spindle drives the take-up gearwheels (32) on the tumbler gear. On the centre of rotation of the tumbler gear there is a gearwheel (40) with a toothed belt wheel (41). The gearwheel is driven by the take-up gears and the toothed belt wheel takes over the drive of the gear combination on the change-over cutter.

9. Description of modules

9.2.5 Tumbler wheel adjustment

As shown in the diagram (2.2) the right-hand wheel on the tumbler gear is engaged in the gear-wheel of the main spindle.

This setting is for LH threads, i.e. if the spindle is turning in an anti-clockwise direction (looking at the chuck), then the tooling carriage will move away from the chuck.

If clamping bolt (36) is slackened, then the tumbler gear can be pivoted over to the right so that the left-hand take-up gearwheel engages the gearwheel of the main spindle. With this setting you can then do right-hand threads, or the slide can run as before (given the same direction of turn of the main spindle) towards the chuck.

9.2.6 Protective cover for chuck

The main spindle of the machine will only run when the chuck protective hood (24) is closed.

For safety reasons it is not possible to switch on the machine with the protective hood open.

9.3 Bed with leadscrew drive

9.3.1 Overload coupling

In order to avoid damage to the drive system of the leadscrew an overload coupling is fitted on the leadscrew drive side. The coupling becomes effective when the machine is overloaded and also when the machine hits an end stop in the longitudinal direction.

The coupling is pre-tensed via the hexagonal nuts (18) and are countered against each other.

9.3.2 Setting the bearing play on the leadscrew

On the RH side the leadscrew is placed radially in bearings in a bronze bushing (10) and axially in two axial bearings (9;8). These two axial bearings allow the leadscrew (6) to be adjusted so that there is no play.

If you have to adjust the setting of the bearings, then first of all the outer of the two capstan nuts (14) must be slackened. Then the inner nut is turned against the axial bearing so that the lead-screw has no more air axially.

Then the outer capstan nut is countered against the inner one.

9. Description of the modules

9.4 Tooling carriages

9.4.1 Cross slide

The cross slide is situated at the front on a prismatic guide and at the back on a flat surface guide. The slide is held to the bed from below by means of guide rail (46). At the front on the RH side is the cylindrical screw (39). With the help of this cylindrical screw, clamp (76) can be clamped up against the underside of the prismatic guide. This clamp is suitable for transverse turning and slicing.

The dove-tailed guide of the cross slide can be adjusted. If you wish to make an adjustment, then first you must loosen hexagonal nuts (12). Tighten threaded pins (45) so that the slide can move backwards and forwards along with ball-ended crank (57). After adjusting, tighten hexagonal nuts (12) again.

You can also adjust any axial play which occurs in spindle (38) of the spindle bearing. If you wish to make an adjustment first of all you have to loosen threaded pin (29). Now scale support (27) can be turned to the right until there is no more axial play. Then tighten threaded pin (29) again.

After making the adjustment the spindle must still be free to turn easily.

For calculating the displacement path of the slide on scale support (27) there is a large scale ring (29) divided into millimetres. One notch corresponds to 0.05 mm of adjustment and this corresponds to the same amount of shaving on the workpiece. This means that in reality the slide is only adjusted by 0.025mm, whereas the diameter of the workpiece changes by 0.05mm.

9.4.2 Top slide

The top slide is clamped via clamp ring (5) on the cross slide upper part (5). Loosen both screws (operational elements Pos. 6) and the top slide can be pushed or turned along the cross slide. This is suitable for lathing short tapered pieces. A scale is engraved on guide ring (2) so that you can read the setting exactly. The zero line is on the cross slide upper part.

The dove-tail guides of the top slide can be adjusted as described for the cross slide. The parts have a different numbering in the drawing: hexagonal nut (11), threaded pins (10), ball-ended crank (24).

Likewise, as described in the case of the cross slide, the axial play of the spindle can be adjusted. Here the parts are numbered differently: spindle (21), spindle bearings (19), threaded pin (26), scale support (27).

9. Description of modules

9.4.2 Top slide

As described in the case of the cross slide, the top slide has also got a read-off scale for its travel path. Here, one notch corresponds to 0.05mm of movement. Since you do not work with diameters on the top slide, then this 0.05 mm corresponds to the actual path. A complete turning of the crank corresponds to a path of 1mm.

9.5 Tailstock

The tailstock can be pushed along the lathe bed and can be lightly clamped in all positions by tightening hexagonal nut (13). The tailstock consists of an upper and lower part. The upper part can be displaced slightly for turning long, slim tapered parts, maximum 10mm.

To do this please proceed as follows:

Loosen hexagonal nut (13) and with the help of the two threaded pins (9) push the upper part in the desired direction.

The central position of the tailstock is shown by the notch embossed on the side. Find out by doing some trial turns if the workpiece is cylindrical and if necessary correct the tailstock setting.

Solid tailstock sleeve:

The solid tailstock sleeve, which is provided with a millimetre scale (5), is designed in such a way that the lathe centre, drill barrel or chuck are **automatically ejected** when turning back.

Tool clamping:

An **inner cone CM 2** which is worked into the tailstock sleeve (4) serves to accept the tools. By screwing the upper T-handle (7), the tailstock sleeve can easily be clamped in any position. The tailstock sleeve can be moved axially over a threaded spindle by using the crank (25) located at the rear end.

10. Applications

10.1 Longitudinal and transverse turning

Longitudinal turning:

In the case of longitudinal turning tool moves parallel to the axis of the workpiece. For roughing at longitudinal turning the use of either a straight or arcuated turning tool is favourably. For smoothing the use of pointed or broad turning tools is favourable.

Transverse turning:

The tooling of the face is known as transverse turning. In the case of transverse turning, the turning tool is moved at 90 degrees to the turning axis of the piece being turned. In so doing the compound rest is to be locked. The main cutting edge of the turning tool is to be exactly centred so that no scar remains in the middle of the workpiece. The arcuated tool is used for transverse turning.

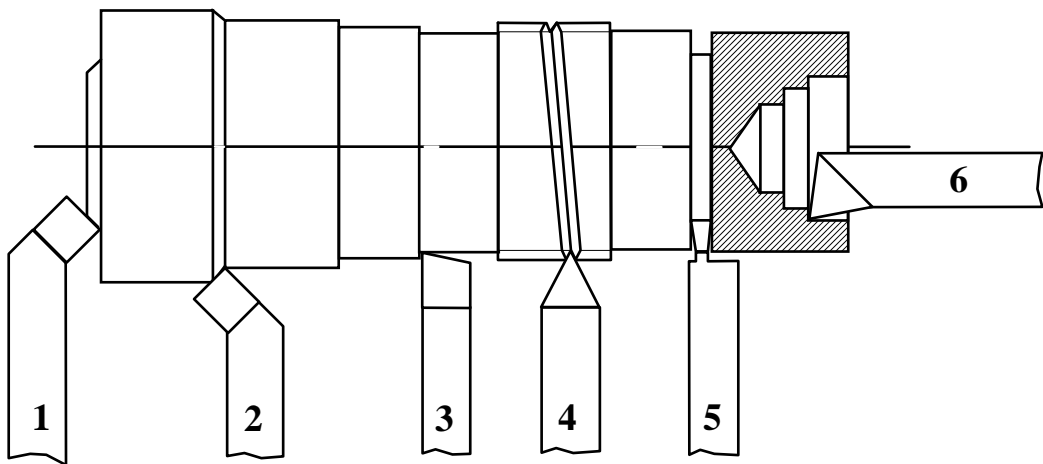

to 1+2: Roughing tools arcuated to the left and or right: By using them a maximum on material is to be cut off in as short a time as possible (without paying attention to the finish on the surface of the work piece). They can be used for longitudinal and transverse turning.

to 3: Offset side turning tool: Used for smoothing (clean surface) in the case of longitudinal and transverse turning.

to 4: Outside thread turning tool: Used for cutting of outside threads.

to 5: Narrow square-nose cutting tool: Used for the cutting of grooves and slicing of workpieces.

When inserting the slicing tool No. 5, pay careful attention to the exactness of the centre height of the turning tool. Work with low speed and cool the tool (use soluble oil or emulsion for cooling: serves to lubricate and for the removal of chips.) The slicing tool is to be clamped as short as possible and at 90° degrees to the workpiece.

to 6: Right side tool: Used for the hollowing-out of boreholes. Clamp as short as possible in order to avoid ascillations of the turning tool which might otherwise occur (uneven surface).

10. Applications

10.1 Longitudinal and transverse turning

For the reason of the power at the turning chisel take care that the tool is short and fast fixed. If the lever arm is too long the turning chisel curves and springs back. The cutting part enters uneven into the workpiece and is producing a wavy surface.

Take care that the turning chisel is placed on the middle of the turning piece. The control of the height position of the middle of the workpiece is done with the live lathe center in the tailstock.

For the regulation of the height position of the turning chisel use with straight sheet steel pieces.

10.2 Thread cutting and automatic feed

10.2.1 Thread cutting

The thread turning chisel is a form turning chisel with the profile of the thread to be cut. It is ground according to jigs (diagram 1) and must be adjusted exactly to the middle of the workpiece as, otherwise, the profile of the thread would be distorted.

In order to obtain the correct position of the flanks of the thread to the axis of the workpiece, the grinding jig is put against the work piece and the turning tool is adjusted in accordance with it.

The feed of the thread turning chisel is affected via the leadscrew, and must correspond to the thread pitch. The gearwheels in the accessories establish the connection between the feed gears and the leadscrew. By fitting different combinations of gearwheels it is possible to cut metric and inch RH and LH threads. The different axis distances of the toothed wheels can be adjusted by pivoting the cutting edge and adjusting the cutting screws.

The feed is switched on by hand on the cam box. When cutting thread, please make sure that the feed remains continuously switched on so that the turning chisel always goes back to the same position when carrying out several cuttings. For this reason, when the cutting is finished, the turning chisel is disengaged from the cross slide because otherwise the flanks and the cuts would be damaged. The chisel is taken back to its home position via the reversing switch by means of a change of direction of the motor. It is advisable to cut a 4-5 mm wide groove on the thread end in order to be able to disengage the threading tool better.

In the case of a long thread diameter, the lathe centre should travel along with the cutting head in order to avoid the workpiece from being pushed to one side.

Diagram 1: Setting the thread turning chisel

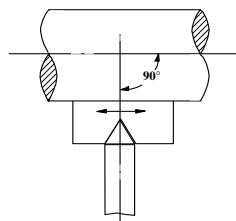

10. Applications

10.2.2 Application of change gears

For the purpose of automatic longitudinal turning there are two feed rates, being at your disposal: 0,085 mm and 0,16 mm/revolution. (Upon delivery, the gears producing a feed of 0,085 mm/revolution have been put on).

Putting on different combinations of gears enables you to cut metric thread ranging from 0,4 to 3,0 mm in pitch. The same applies to inch thread ranging from 10 threads/" to 32 threads/" in pitch.

Table on thread cutting

mm	0,4	0,5	0,7	0,75	0,8	1,0	1,25	1,5	1,75	2,0	2,5	3,0
	A	48	48	48	48	48	48	48	48	48	48	48
B	16	20	14	18	16	14	20	36	28	40	40	48
C	40	40	20	24	20	14	16	24	16	20	16	16
D	140	140	140	140	140	140	140	140	140	140	140	140
E	140	140	120	120	120	120	120	140	120	140	140	140
* = Extras												
Z/1"	10	11	12	13	14	16	18	19	20	24	28	32
A	34	34	34	34	34	34	34	34	34	34	34	34
B	36	36	36	36	36	36	14	34*	18	24	18	18
C	20	22	24	26*	28	32	14	36	20	32	28	32
D	120	120	120	120	120	120	120	120	120	120	120	120
E	140	140	140	140	140	140	120	140	120	140	140	140

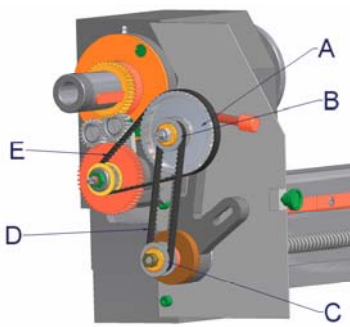
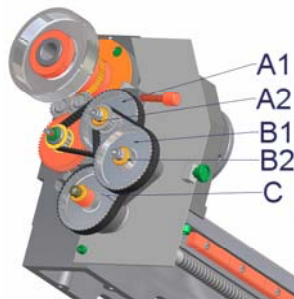

Table automatic longitudinal feed

mm/σ	0,085	0,16
	A1	48
A2	14	18
B1	48	48
B2	14	20
C	48	48



10. Applications

10.2.3 Altering the feeds or thread pitches

When altering the feeds or thread pitches, proceed as follows:

1. Changing the feed from 0,085 mm to 0,16 mm

- a. Loosen the fixing screw D of the change gear quadrant.
(First loosen the knurled screw at the front of the headstock and open the protective cover.)
- b. Loosen and remove the hexagonal nuts and washers from the bolts A and B.
- c. Loosen the hexagonal bolts A and B. Remove the toothed belt connecting A and B. Turn bolt B out of the cutter with the two tooth pulleys and take them out. Remove toothed belt of drive disc to A.
- d. Remove both tooth belt pulleys Z 14 from their bolts A and B and change them for tooth belt pulley Z 18 or tooth belt pulley Z 20, respectively.
- e. Mount bolt B, together with both tooth belt pulleys into the change gear quadrant again by slightly tilting the bolt and screwing it into the square nut located behind the quadrant. Put on the toothed belt connecting B and C, pull bolt B upwards imparting tension to the toothed belt. Then, tighten bolt B. Put toothed belt of of drive disc on bolt A and from bolt A on bolt B.
- f. Pull bolt A upwards until the toothed belt is under tension, then tighten bolt A. Move quadrant to the front until toothed belt of drive disc is tensed to bolt A. Then tighten fixing screw D, mount washers and nuts on A and B and tighten.
- g. Close the cover of the headstock and tighten again the screw with hexagonal recessed hole.

2. Changing the feed from 0,085 mm to metrical thread pitch 1,0 mm

- a.-c. Proceed exactly as already described under pos. 1 a-c. The procedure differs merely – as described under 1b - in additionally taking away the hexagonal socket screw off bolt C.
- d. Changing bolt and the tooth belt pulley Z 48 running on bolt C. First push bolt on bolt C, then the tooth belt pulley Z 14.
Bolt B with totoothed belt will not be needed with thread cutting!
- e. As the toothed belt Z14 is already on bolt A you do not have to make any changes. Move the toothed belt from the drive disc to bolt A and from A to C..
- f. - g. Proceed as described under pos. 1, f-g!

10. Applications

10.2.3 Altering the feeds or thread pitches

3. Changing the feed from 0,085 mm to a metric pitch of 1,5 mm

Start the procedure exactly as already described. Only toothed belt pulley Z 48 on bolt A has additionally to be substituted by toothed belt pulley Z 34.

The feed is switched over via the lever grip on the front side of the cam box. When cutting thread please make sure that the feed remains permanently switched on so that the turning chisel gets into the same position every time in the case of several cuttings.

For this reason, when you have finished cutting, the chisel is turned out with the cross slide and is brought back by means of a change of direction of the motor via the reversing switch into the original position.

10.2.4 LH thread

To cut an LH thread all you have to do is bring the RH take-up wheel on the tumbler gear and link it into the drive wheel on the main spindle.

In figure 2.4 you can see the position when cutting an LH thread. In order to pivot the tumbler gear all you have to do is loosen the clamping screw.

11. Three-jaw chuck and four-jaw chuck

The three-jaw chuck

serves to clamp circular, triangular and hexagonal workpieces centrically to the spindle axis.

The four-jaw chuck

serves to clamp square workpieces centrically to the spindle axis.

Danger of accident

Do not try to clamp larger workpieces. The chucking power is then too low and the jaws can detach themselves.

Mounting of turning jaws:

The jaws and guides are numbered from 1-3. Open the chuck by means of the chuck key until the jaws loosen. (order: 3, 2, 1 bzw. 4, 3, 2, 1).

Now, take the inner jaws beginning with the number 1 and put this in the guide number 1. Push the jaw number 1 in the direction of the centre point of the chuck and at the same time turn the chuck key (direction "tighten"). When the transverse spiral has taken hold of number 1, number 2 must be put in the guide provided. The same now happens to number 2 as to number 1. Proceed with number 3 and number 4 in the same way. Subsequently, examine the position of the jaws.

Mounting of drilling jaws:

If, afterwards, you again want to work with outer jaws, the process repeats itself in the same order (first jaw 1, then 2, then 3, then 4).

12. Tool holder with conical sleeve



Only those workpieces may be used which accord to the nominal diameter of the collet chuck.

Mounting of the tool holder:

When working with the collet chuck, the concentric chuck must be removed from the workspindle. In order to do this, loosen the three tightening screws by means of the Allan key SW6 included in the accessories. Now, the chuck can be lifted from the concentric flange of the workspindle and the closer can be inserted into the workspindle by gently pushing it.

Subsequently, insert the required collet chuck into the closer and by means of the hand draw-in tube (which is fed in through the hollow workspindle from the gear side) draw the collet chuck into the closer.

13. Square turret head

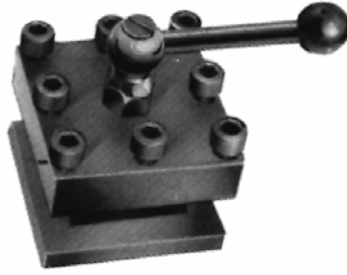

The square turret head is used instead of the clamping plate in order to clamp the tools.

Four turning tools can be changed simultaneously. By swivelling the turret head by 90 degrees each time, the required turning tool can quickly be brought into its working position. Advantage: Parting chisels are always in the centre after being adjusted just once.

14. Unit for lubrication coolant

The unit for lubrication coolant consists of:

1. Tray with lubrication coolant sump which collects the lubrication coolant mixture for the feed pump. Contents generally 19 litres.
2. Feed pump with the following electrical data
 - nominal voltage 230 V
 - frequency 50 Hz
 - nominal current input 0,4A
 - nominal output 0,07 kW
 - ON-OFF switch and mains lead with a length of 2 m complete with earthed plug.
3. Adjustable, flexible pressure tubing with stop valve and nozzle for transporting the lubrication coolant to the processing point.

An increasing number of customers wish to include this fixture in their order so as to take advantage of "wet processing" for the production of their goods / workpieces and to:

- to cool and lubricate, in particular during lengthy processing
- when processing high alloy steel and aluminium
- to increase the tool life
- to improve the surface finish and accuracy of the workpieces
- to reduce friction heat
- to prevent built-up edges

When using lubrication coolants, especially water based emulsions, a number of health and safety measures must be observed, which we would like to recommend as follows:

1. Use concentrated products free of nitrates.
2. Use concentrates without secondary amines.
3. Use products with the lowest possible allergy potential.
4. When mixing a refill of lubrication coolant, please observe the following:
 - clean / rinse the circulation system (tray / filter)
 - determine the concentration necessary to meet the technical demands (concentrate: water 1:5 – 1:30)
 - check the water has a low level of nitrates (< 50 mg NO₃⁻, test strip)
5. A cleaning plan should determine at what intervals the system should be cleaned of swarf and other waste.
6. A service plan should determine the following.
 - when to check the concentration in use (daily / weekly)
 - when to check the pH values (weekly)
 - when to check / assess the bacteria count (monthly)
 - when to check the nitrate content (weekly)(The information in brackets can be varied according to the production circumstances.)
7. In order to reduce splashing, we recommend the attachment of a splash guard and / or reducing the amount sprayed from the nozzle.
8. Since steps to protect the skin must be taken, it is advisable to wear gloves and aprons. The skin should be cleaned with acidic syndets without abrasive ingredients and rich cream should be applied to regenerate the skin.
9. Please also take note of the enclosed information on the general operating instructions.

15. Declaration of noise levels in accordance with DIN EN 24871 (German Industrial Standard)

Noise levels while running idle

Acoustic capacity level	67 dB (A)
Sound pressure level on operator's ear	63 dB (A)

The stated values reflect emission levels and not necessarily working levels. Although there is a correlation between the level of emission and the level of stress, this cannot be used reliably in order to determine whether additional safety measures are necessary or not.

Other factors which influence the actual stress level on employees are the characteristics of the working area, other sources of noise, i.e. the number of machines and other processes going on nearby and so on. Apart from that, the permitted stress levels may vary from country to country. This information is to allow the user of the machine to assess the dangers and risks more accurately.

16. Disposal of the lathe

The transport and protective packaging made up of the following materials:

- corrugated cardboard
- polystyrene free of freon
- polyethelene foil
- non-returnable wooded pallet (untreated)
- Euro pallet (deposit)

If you have no further need of these articles or do not wish to use them again, please dispose of them at the public recycling facilities.

The lathe consists of up to 98 % of recyclable materials, i.e. steel, cast iron, aluminium and 2 % of chemical materials, e.g. the coating of electrical leads, printed circuits.

If you have trouble disposing of these parts in a proper manner, we would be pleased to help you. Upon mutual agreement we will take the complete machine back and dispose of it. However, the costs for transporting the machine to our plant must be at your expense.



Montageanleitung

für

Digitale Längenmessleisten zu WABECO Drehmaschinen

zu D4000 E und CC-D4000 E

Bestell-No. No. 10499



Walter Blombach GmbH
Werkzeug- und Maschinenfabrik

Übersicht

Sehr geehrter Kunde!

Mit dem Kauf der **digitalen Längenmessleisten** haben Sie sich für ein präzises Koordinatenmesssystem entschieden.

Diese Montageanleitung soll Ihnen helfen, Ihre digitalen Messleisten richtig zu montieren. Deshalb bitten wir Sie, die entsprechenden Hinweise aufmerksam durchzulesen und sorgfältig zu beachten.

Nach dem Auspacken der Messleisten ist zu prüfen, ob Transportschäden irgendwelcher Art aufgetreten sind. Beanstandungen, gleich welcher Art, sind sofort zu melden. Spätere Reklamationen können **nicht** anerkannt werden.

Bitte überprüfen Sie vor dem Anbau der Messleisten deren Funktionen, d.h. Ein- Aus-Schalten, Umschalten von mm auf inch, Reset- und Presetfunktion etc.

Inhaltsverzeichnis

1. Montage	2
1.1 Position der Längenmesssysteme	2
1.2 Vorbereitende Bohrarbeiten vor der Montage	2
1.3 Montage der Längenmessleisten und Halter	3
1.3.1 Montage X-Achse	3
1.3.2. Montage Z-Achse	5
1.3.3. Montage Z1-Achse (Längsschlitten)	7
1.4 Montage Allgemein	8
1.4.1 Digitale Längenmessleisten	8
1.4.2 Die Anzeigeeinheit	9
1.4.3. Fehlerbehandlung	11

1 Montage

1.1 Position der Digitalen Längenmessleisten

Im Anhang zu der Montageanleitung finden Sie eine Montageskizze, in welcher die Positionen der einzubringenden Gewindebohrungen dargestellt sind.

1.2 Vorbereitende Bohrarbeiten vor der Montage

Erfahrungsgemäß ist es sehr schwierig, alle angegebenen Bohrungen an einer montierten Maschine nach Zeichnung einzubringen. Aus diesem Grunde empfehlen wir die Gewindebohrungen zunächst anzukörnen und vor dem Bohren die Teile anzuhalten und deren Lage zu überprüfen.

1.3 Montage der Längenmessleisten und Halter

1.3.1 Montage X-Achse

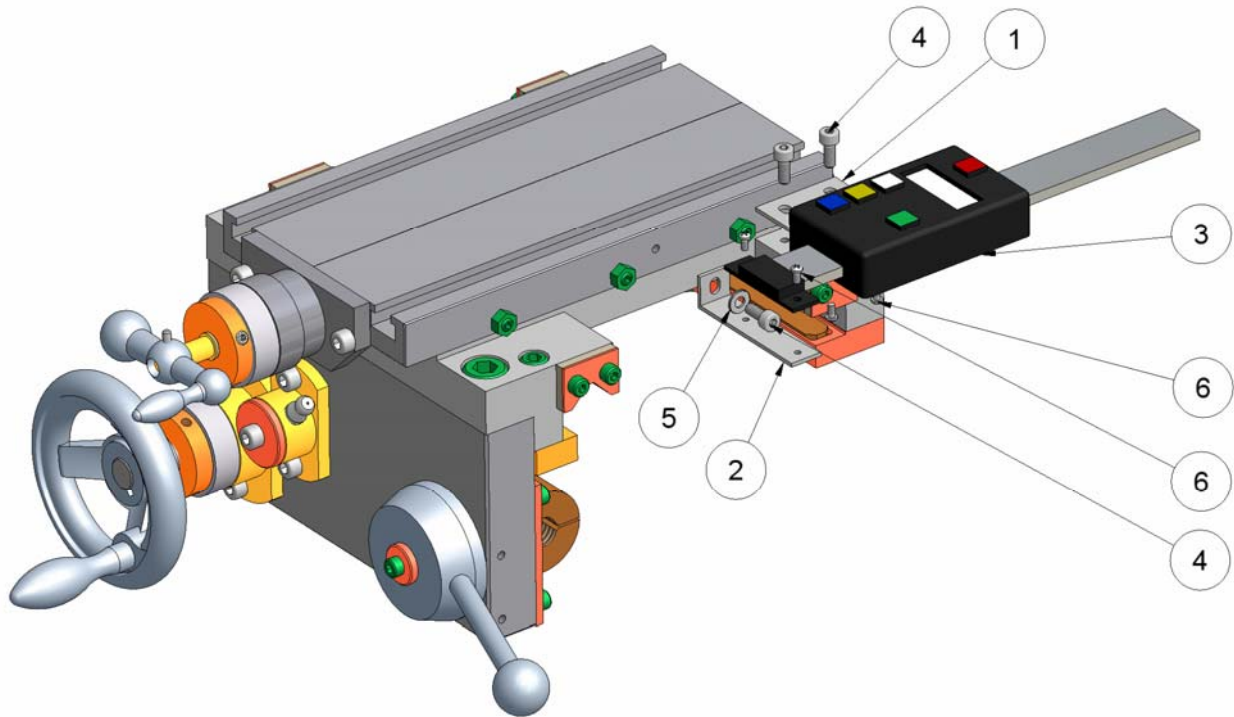

Teil-Nr.	Stück	Bestell-No.	Bezeichnung
1	1	10499-6	Noniushalter X-Achse
2	1	10499-5	Halter Messleiste X
3	1	11370	Messleiste 100 mm
		(gekürzte Version)	Gesamtlänge auf 185 mm gekürzt
4	3	16191200004010	Schrauben M4x10
5	1	16112500004000	Unterlegscheibe 4,3
6	4	16191200003006	Schrauben M3x6

Sollten sie eine ungekürzte Längenmessleiste erhalten, müssen sie diese mit Hilfe einer Trennscheibe von der rechten Seite auf eine Gesamtlänge von 185mm kürzen!

1.3 Montage der Längenmessleisten und Halter

1.3.1 Montage X-Achse

Position der einzubringenden Bohrungen:

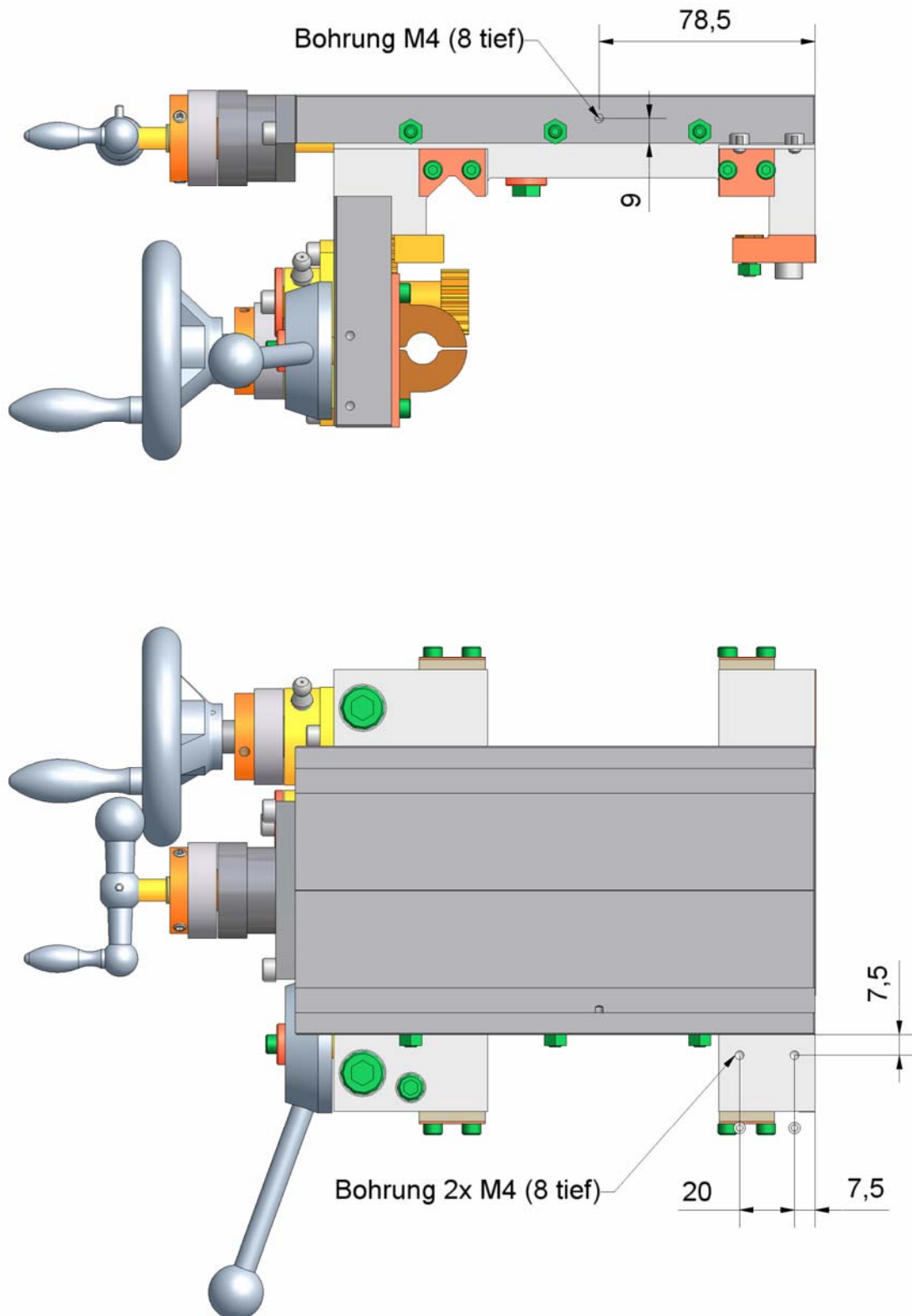

1.3 Montage der Längenmessleisten und Halter

1.3.2 Montage Z-Achse

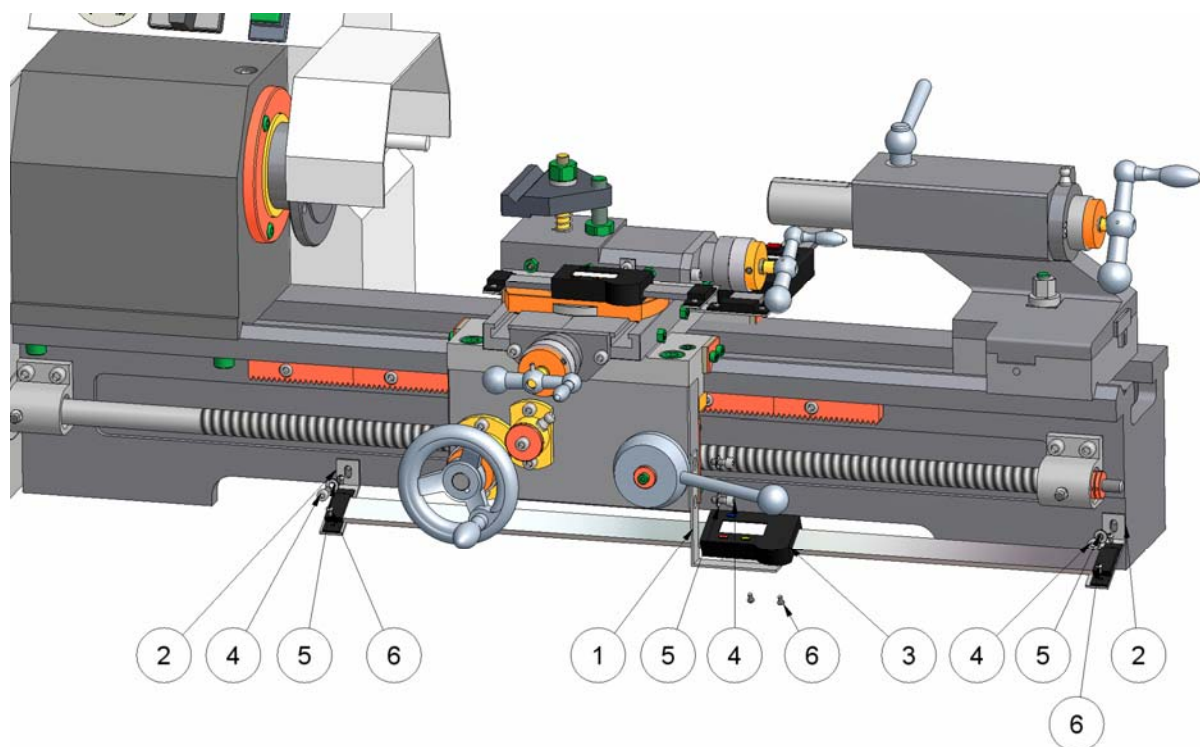

Teil-Nr.	Stück	Bestell-No.	Bezeichnung
1	1	10499-1	Noniushalter Z-Achse
2	2	10499-2	Halter Messleiste Z-Achse
3	1	11364	Längenmessleiste
4	4	16191200004010	Schrauben M4x10
5	4	16112500004000	Unterlegscheibe 4,3
6	6	16191200003006	Schrauben M3x6

1.3 Montage der Längenmessleisten und Halter

1.3.2 Montage Z-Achse

Position der einzubringenden Bohrungen:

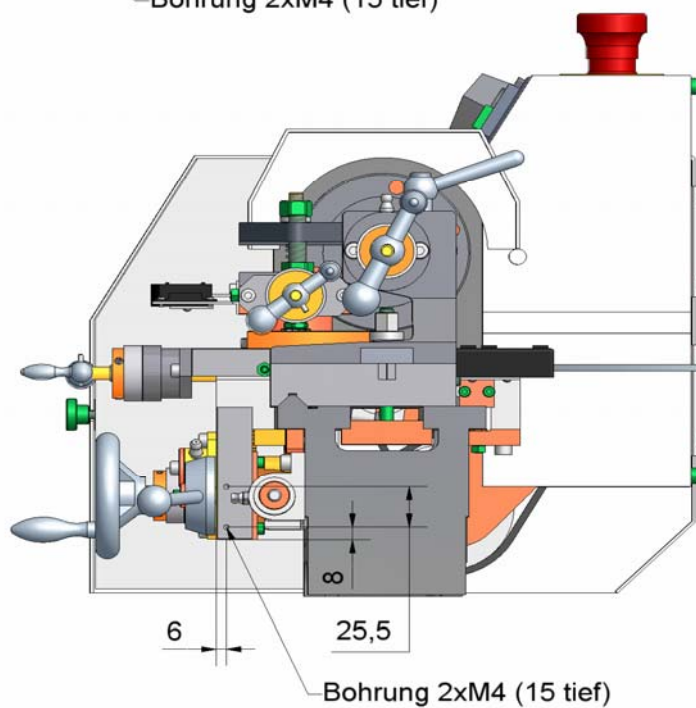
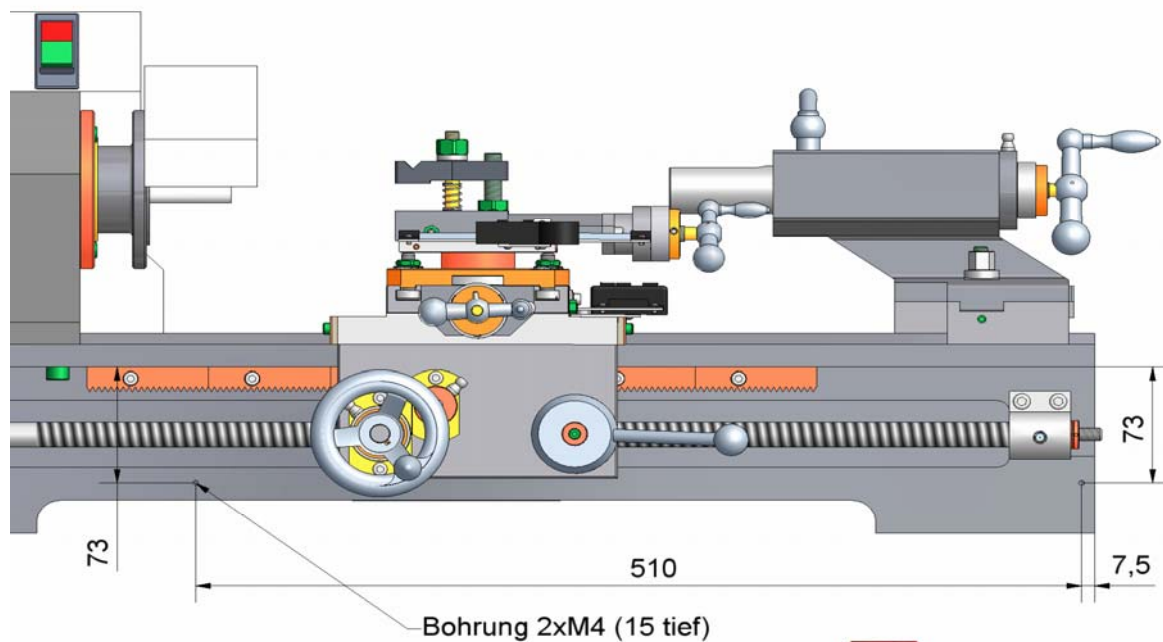

1.3 Montage der Längenmessleisten und Halter

1.3.3 Montage Z1-Achse (Längsschlitten)

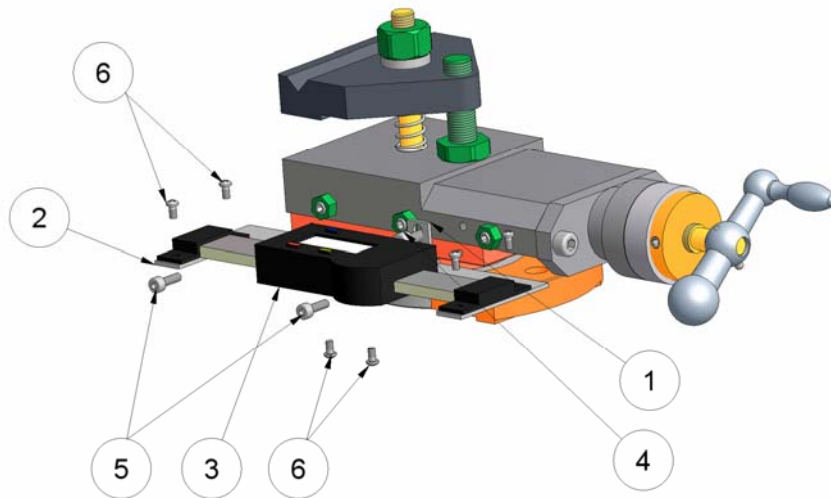

Teil-Nr.	Stück	Bestell-No.	Bezeichnung
1	1	10499-3	Noniushalter Z1
2	1	10699-3	Halter Längsschlitten
3	1	11360	Messleiste 100 mm (gekürzte Version)
4	1	16191200004010	Schrauben M4x10
5	2	16191200003010	Schrauben M3x10
6	6	1619120003006	Schrauben M3x6

Sollten sie eine ungekürzte Längenmessleiste erhalten, müssen sie diese mit Hilfe einer Trennscheibe von der rechten Seite auf eine Gesamtlänge von 140mm kürzen!

Position der einzubringenden Bohrungen:

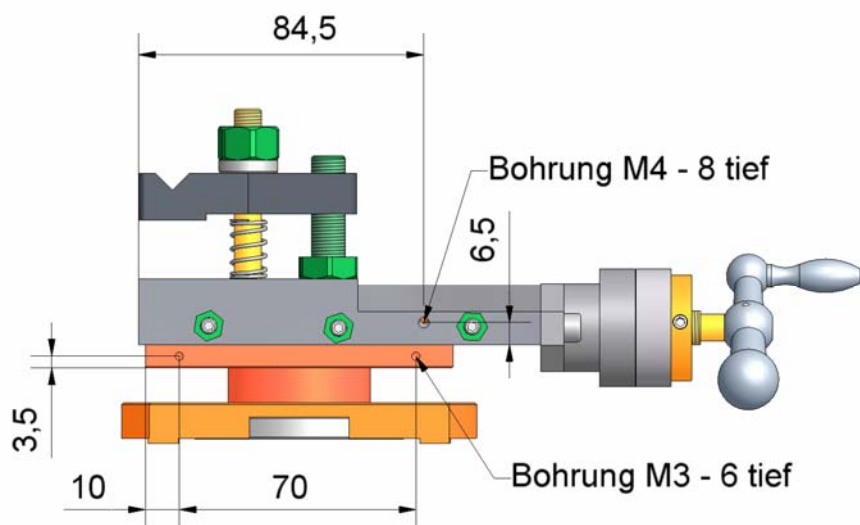

1.4 Montage Allgemein

Bei der Montage aller Längenmessleisten beachten Sie bitte, dass beim Anschrauben der Leisten und Halter es zu keiner Verspannung oder Verbiegung der einzelnen Komponenten kommt.

Sollten sie eine ungekürzte Längenmessleiste erhalten, müssen sie diese mit kürzen!

Bei Verwendung von schnelllaufenden Trennscheiben muss für ausreichend Kühlung gesorgt werden um eine zu hohe Wärmeentwicklung zu vermeiden.

- Schlittenbewegung auf Leichtgang überprüfen
- Befestigungsschrauben nachziehen.

1.4.1. Digitale Längenmessleisten

Qualität: Nichtrostender Stahl, ganz gehärtet.

Verwendung: Für den Einbau an Maschinen in waagerechter oder senkrechter Einbauweise.

Messbereich und Messgenauigkeit

Messbereich	Messgenauigkeit	Messbereich	Messgenauigkeit
0 – 100	0,03 mm	0 – 6“	0,001“
0 – 200	0,03 mm	0 – 8“	0,001“
0 – 300	0,04 mm	0 – 12“	0,0015“
0 – 500	0,05 mm	0 – 20“	0,002“
0 – 1000	0,07 mm	0 – 40“	0,0025“

Messsystem

Anzeige:	0,01 mm/0,0005“
Wiederholgenauigkeit:	0,01 mm/0,0005“
Meßgeschwindigkeit:	max. 1,5 m/sec
Meßsystem:	Berührungsfreies Linear-Meßsystem (CAP)
Anzeige:	5-stellige LCD-Anzeige mit Minus-Anzeige
Datenausgang:	RS232C-Schnittstelle
Batterie:	Silber-Oxyd-Batterie 1,5 V (LR44, SR44)
Arbeitstemperatur:	ca. 0-40°C
Lagertemperatur:	ca. -20 – 70°C
Feuchtigkeitseinfluß:	keine Einschränkung bei einer Luftfeuchtigkeit von 80° relativ.
Unterspannungsüberwachung:	Unterspannungswarnung durch Intermittierende Anzeige.

1.4 Montage Allgemein

1.4.2. Die Anzeigeeinheit

1. Messschieber mit normaler Anzeige

- mm/inch Taste: Umschalten zwischen mm und inch.
- EIN/AUS-Taste: Schaltet die Anzeige ein und aus.
- Zero-Taste: Nulltaste



2. Messschieber mit Multifunktionsanzeige

- mm/inch Taste: Umschalten zwischen mm und inch.
- EIN/AUS-Taste: Schaltet die Anzeige ein und aus.
- RS232C: für den Anschluß eines PC-Interface oder eines Extra-Anzeigegeräts.
- Abs/inc-Taste: Umschalten zwischen Absolut- und Relativmessung.
- Set-Taste: Setzt die Anzeige auf einen voreingestellten Wert ein (Der Voreinstellwert ist 0).
- “-“-Taste: für die Einstellung der Set-Taste
- “+“-Taste: für die Einstellung der Set-Taste

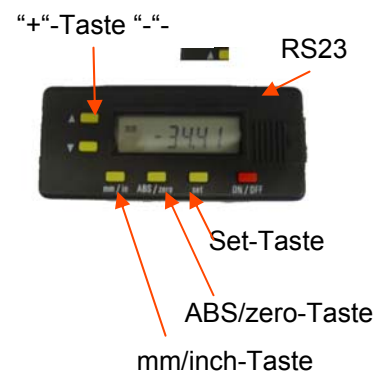

Einstellung der Set-Taste:

Durch gleichzeitiges Drücken von “SET“-Taste und einer von “+“ oder “-“-Taste erscheint in der Anzeige ein kleines blinkendes “SET“. Danach kann der Anzeigewert durch Drücken von “+“-Taste erhöht oder durch Drücken von “-“-Taste erniedrigt werden. Man drückt “+“ oder “-“-Taste solange bis der gewünschte Wert in der Anzeige erreicht ist. Danach drückt man nochmal die “SET“-Taste. Der Wert für die Set-Taste ist damit eingestellt.

Bei Drücken von “SET“-Taste wird die Anzeige auf den voreingestellten Wert gesetzt.

3. Anzeige mit Preset-Taste

Diese Anzeige hat folgende zusätzliche Funktionen:

Mode-Funktion

Mit der Mode-Taste wird die Anzeige zwischen Relativ- und Absolut-Messung umgeschaltet. Die relative Messung wird durch “INC“ in der Anzeige gekennzeichnet.



Preset-Funktion

Bei dieser Anzeige wird die Anzeige mit der “ZERO“-Taste nicht automatisch auf “0“, sondern auf den eingestellten Preset-Wert gesetzt. Der Preset-Wert kann mit der “ZERO“-Taste und den Preset-Tasten eingestellt werden.

1.4 Montage Allgemein

1.4.2. Die Anzeigeeinheit

mm/inch-

So funktioniert es:

Drücken Sie die "ZERO"-Taste und einer der Preset-Tasten, dann erscheint ein blinkendes „SET“-Zeichen, danach kann der Wert in der Anzeige durch Drücken von "+"-und "-"-Taste auf einen beliebigen Wert eingestellt werden. Danach drücken Sie nochmal auf die "ZERO"-Taste und der Preset-Wert ist einstellt und erscheint bei Drücken der "ZERO"-Taste auf der Anzeige.

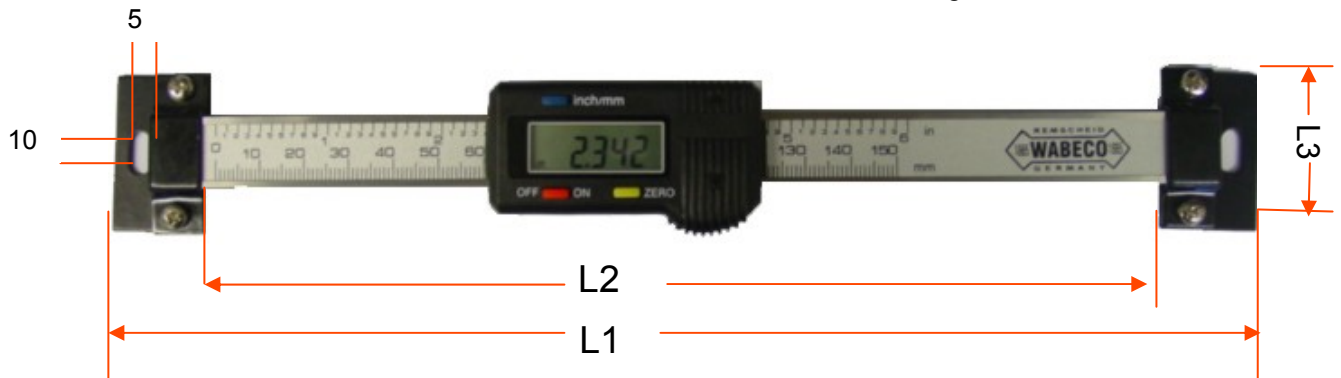

MB (mm)	150	200	300	400	500	600	800	1000
L1 (mm)	299	340	455	552	680	785	985	1185
L2 (mm)	249	290	405	502	615	720	920	1120
L2 (mm)	35	35	35	35	43	43	43	43

Bemerkung:

- Alle Maße sind ca. Maße
- Die Maße L1 und L2 weichen bei senkrechten Einbaumessschiebern geringfügig von der Tabelle ab.
- Die angegebenen Messbereiche sind Nenn-Meßbereiche. Die tatsächlichen Messbereiche sind etwas länger als die Nennangabe.

Bedienungsanweisung:

- Maßstabkörper sauber halten. Verhindern Sie das Eindringen von Flüssigkeit in die Anzeigeeinheit, da sonst die Elektronik zerstört würde.
- Die Oberfläche kann mit Reinigungsmittel gereinigt, die Metallteile mit etwas Maschinenöl eingefettet werden. (Bitte Aceton oder Alkohol nicht benutzen)
- Die Abdeckkappe der Datenschnittstelle nur zum Einführen des Datensteckers öffnen. Die Kontakte nicht mit Metall in Berührung bringen, da die Elektronik sonst zerstört werden kann.
- Bei Lagerung sowie längerer Nichtbenutzung bitte die Batterie aus dem Batteriefach entfernen!
- Sonstige Bedienungshinweise wie bei einer herkömmlichen Schieblehre.

Hinweis:

Bei längerer Nichtbenutzung oder Lagerung des Messschiebers nehmen Sie bitte die Batterie raus, da die Batterie aufgrund des Ruhestroms trotz der Abschaltung der Anzeige verbraucht werden kann. Dies gilt insbesondere für Messschieber mit Anzeigeeinheit, die mit automatischer Abschaltung oder mit "Hold"-Funktion ausgestattet sind!

1.4 Montage Allgemein

1.4.3. Fehlerbehandlung

Fehler	Grund	Behebung
Die Zahl blinkt ca. 1 mal pro sec.	Batteriespannung unter 1,45 V	Batteriewechsel vornehmen
Das Display zählt nicht weiter	Stromkreisfehler (Resetfehler)	Batterie heraus nehmen und nach ca 1 min. einlegen
Display zeigt nur 000.00	Bedienungsknopf hat Kurzschluß	Abdeckhaube abschrauben u. die Feder der Knöpfe richtig einsetzen
Funktion der Bedieknöpfe nicht aktiv	Durch zu starken Druck a. d. Taste Feder verklemmt	Wie oben
Der Messfehler über die volle Länge ist 0,1 mm	<ol style="list-style-type: none">1. Einstellschraube locker2. Schmutz ist in den Abtastkopf gelangt.	<ol style="list-style-type: none">1. Schraube nachstellen.2. Kundendienst in Anspruch nehmen
Keine Anzeige	<ol style="list-style-type: none">1. Batterie hat schlechten Kontakt2. Batteriespannung unter 1.1 V3. Anzeige defekt.	<ol style="list-style-type: none">1. Deckel entfernen. Batterie richtig einsetzen.2. Batterie einsetzen.3. Kundendienst