

RC6236×1000

GEARED HEAD PRECISION LATHE

OPERATION MANUAL

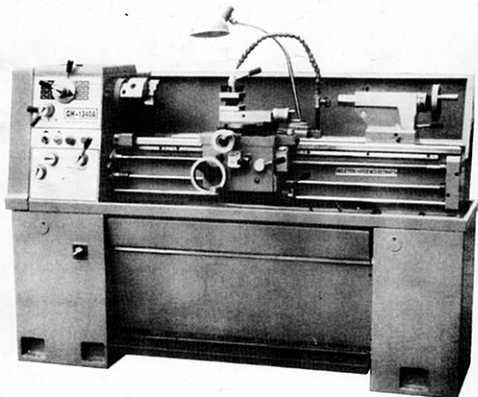

 **WARNING**

1. Read and understand the entire instruction manual before operating machine.
2. Always wear approved safety glasses/face shields while using this machine.
3. Make certain the machine is properly grounded.
4. Before operating the machine, remove tie, rings, watches, other jewelry, and roll up sleeves above the elbow. Remove all loose clothing and confine long hair. Do not wear gloves.
5. Keep the floor around the machine clean and free of scrap material, oil and grease.
6. Keep machine guards in place at all times when the machine is in use. If removed for maintenance purposes, use extreme caution and replace the guards immediately.
7. Do not over reach. Maintain a balanced stance at all times so that you do not fall or lean against blades or other moving parts.
8. Make all machine adjustment or maintenance with the machine unplugged from the power source.
9. Use the right tool. Don't force a tool or attachment to do a job which it was not designed for.
10. Replace warning labels if they become obscured or removed.
11. Make certain the motor switch is in the OFF position before connecting the machine to the power supply.
12. Give your work undivided attention. Looking around, carrying on a conversation, and "horse-play" are careless acts that can result in serious injury.
13. Keep visitors a safe distance from the work area.
14. Use recommended accessories; improper accessories may be hazardous.
15. Make a habit of checking to see that keys and adjusting wrenches are removed before turning on the machine.
16. Never attempt any operation or adjustment if the procedure is not understood.
17. Keep fingers away from revolving parts and cutting tools while in operation.
18. Keep belt guard in place and in working order.
19. Never force the cutting action.
20. Do not attempt to adjust or remove tools during operation.
21. Always keep cutters sharp.
22. Always use identical replacement parts when servicing.
23. Failure to comply with all of these warnings may cause serious injury.

GH-1340A(C6232A2)**Specifications:****Capacities:**

Swing Over Bed	13"(330mm)
Swing Over Cross Slide	7-5/8"(195mm)
Swing Over Gap	19"(480mm)
Length of Gap	9-3/8"(238mm)
Distance Between Centers	40"(1000mm)

Headstock:

Hole Through Spindle	1-1/2"(38mm)
Spindle Nose	D1-4 Camlock
Taper in Spindle Nose	MT-5
Spindle Bearing Type	Taper Roller Bearing
Number of spindle Speeds	8 or 16
Range of Spindle Speeds	90 or 45-1800 RPM

Gearbox:

Number of Longitudinal and Cross Feeds	40
Range of Longitudinal Feeds	0.0012"-0.0294"(0.043-0.653mm)
Range of Cross Feeds	0.0004"-0.0108"(0.015-0.22mm)
Number of Inch Threads	40(28)
Range of Inch Threads	4-112 T.P.I
Number of Metric Threads	22(37)
Range of Metric Threads	0.45-7.5mm(0.4-7mm)
Leadscrew	7/8" x 49-1/2"(22mm x 1258mm)
Feed Rod Diameter	3/4"(19mm)

Compound and Carriage

Toolpost Type	4-Way
Maximum Tool Size	5/8" x 5/8"(16 x 16mm)
Maximum Compound Slide Travel	3-1/2"(90mm)
Maximum Cross Slide Travel	6-1/2"(165mm)
Maximum Carriage Travel	37-1/2"(950mm)

Tailstock:

Tailstock Spindle Travel	4-3/4"(120mm)
Diameter of Tailstock Spindle	1-25/32"(45mm)
Taper in Tailstock Spindle	MT-3

Miscellaneous:

Steady Rest Capacity	1/4"-2-5/8"(6.5-65mm)
Follow Rest Capacity	1/4"-2-3/4"(6.5-70mm)
length of Bed	54-1/4"(1380mm)
width of Bed	8"(203mm)
Height of Bed	11"(280mm)
Overall Dimensions	71-3/4" x 30"W x 47-5/8"H 1825mm x 760mm x 1200mm
Main Motor power	3HP(2.2KW)
Net Weight(approx.)	1540lbs.(700Kg)
Shipping Weight(approx.)	1810lbs.(820Kg)

Note: Data in the parentheses are for metric system.

Specifications:**GH-1440A(C6236A2)****Capacities:**

Swing Over Bed	14"(356mm)
Swing Over Cross Slide	8-5/8"(220mm)
Swing Over Gap	20"(506mm)
Length of Gap	9-3/8"(238mm)
Distance Between Centers	40"(1000mm)

Headstock:

Hole Through Spindle	1-1/2"(38mm)
Spindle Nose	D1-4Camlock
Taper in Spindle Nose	MT-5
Spindle Bearing Type	Taper Roller Bearing
Number of Spindle Speeds	8 or 16
Range of Spindle Speeds	90 or 45-1800RPM

Gearbox:

Number of Longitudinal and Cross Feeds	40
Range of Longitudinal Feeds	0.0012"~0.0294"(0.043~0.653mm)
Range of Cross Feeds	0.0004"~0.0108"(0.015~0.22mm)
Number of Inch Threads	40(28)
Range of Inch Threads	4-112.T.P.I
Number of Metric Threads	22(37)
Range of Metric Threads	0.45~7.5mm(0.4~7mm)
Leadscrew	7/8" × 49-1/2"(22mm × 1258mm)
Feed Rod Diameter	3/4"(19mm)

Compound and Carriage

Toolpost Type	4-Way
Maximum Tool Size	5/8" × 5/8"(16 × 16mm)
Maximum Compound Slide Travel	3-1/2"(90mm)
Maximum Cross Slide Travel	7"(180mm)
Maximum Carriage Travel	37-1/2"(950mm)

Tailstock:

Tailstock Spindle Travel	4-3/4"(120mm)
Diameter of Tailstock Spindle	1-25/32"(45mm)
Taper in Tailstock Spindle	MT-3

Miscellaneous:

Steady Rest Capacity	1/4"~2-5/8"(6.5~65mm)
Follow Rest Capacity	1/4"~2-3/4"(6.5~70mm)
Length of Bed	54-1/4"(1380mm)
Width of Bed	8"(203mm)
Height of Bed	11"(280mm)
Overall Dimensions	71-3/4L × 30"W × 48"H 1825mm × 760mm × 1213mm
Main Motor power	3HP(2.2KW)
Net Weight(approx.)	1650lbs.(750kg)
Shipping Weight(approx.)	1936lbs.(880kg)

Note:Data in the parentheses are for metric system.

Table of Contents

Safety Warnings.....	1
Specifications.....	2-3
Table of Contents.....	4
Uncrating and Clean-Up.....	5
Chuck Preparation.....	6
Lubrication.....	7
Electrical Connections.....	8
General Description.....	9-11
Controls.....	11-14
Break-in Procedure.....	14
Operation.....	14-16
Adjustments.....	16-20



WARNING

Read and understand the entire contents of this manual before attempting set-up or operation!

Failure to comply may cause serious injury!

Uncratering and Clean-Up

1. Finish removing the wooden crate from around the lathe.
 2. Unbolt the lathe from the shipping crate bottom.
 3. Choose a location for the lathe that is dry, has good lighting and has enough room to be able to service the lathe on all four sides.
 4. Sling lathe after placing steel rods or pipes (of sufficient strength) into holes of lathe stand as diagrammed in Fig. 1. Do not lift by spindle. With adequate lifting equipment, slowly raise the lathe off the shipping crate bottom. Make sure lathe is balanced before moving.
- ※ 5. To avoid twisting the bed, the lathe's location must be absolutely flat and level. Check for a level condition using a machinist's precision level on the bedways both front to back and side to side. The leveling pads included in the tool box and the leveling screws in the lathe base will help you to reach a level condition. The lathe must be level to be accurate.
6. Clean all rust protected surfaces using a mild commercial solvent, kerosene or diesel fuel. Do not use paint thinner, gasoline, or lacquer thinner. These will damage painted surfaces. Cover all cleaned surfaces with a light film of 20W machine oil.
 7. Remove the end gear cover. Clean all components of the end gear assembly and coat all gears with a heavy, non-slinging grease. Replace cover.
- ※ Note: This step is only for machines with accessory of Leveling pads.

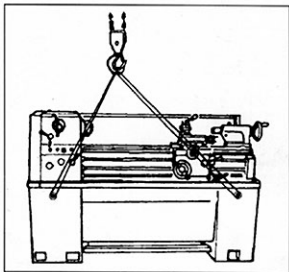

Fig.1

Chuck Preparation(Three Jaw)



WARNING

Read and understand all directions for chuck preparation!

Failure to comply may cause serious injury and/or damage to the lathe!

1. Support the chuck while turning three camlocks 1/4 turn counter-clockwise with the chuck key enclosed in the tool box.
2. Carefully remove the chuck from the spindle and place on an adequate work surface.
4. Inspect the camlock studs. Make sure they have not become cracked or broken during transit. Clean all parts thoroughly with solvent. Also clean the spindle and camlocks.
5. Cover all chuck jaws and scroll inside the chuck with #2 lithium tube grease. Cover the spindle, cam locks, and chuck body with a light film of 20W oil.
6. Lift the chuck up to the spindle nose and press onto the spindle. Tighten in place by turning the cam locks 1/4 turn clockwise. The index mark (A, Fig.2) on the camlock should be between the two indicator arrows (B, Fig.2). If the index mark is not between the two arrows, remove the chuck and adjust the camlock studs by either turning out one full turn (if cams will not engage) or turning in one full turn (if cams turn beyond indicator marks).
7. Install chuck and tighten in place.

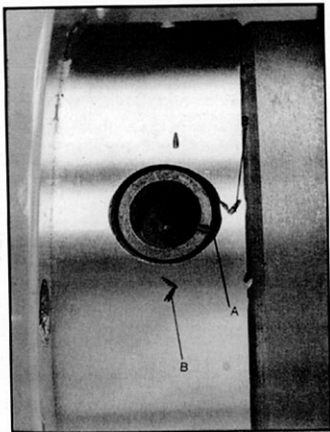

Fig.2

Lubrication



CAUTION

Lathe must be serviced at all lubrication points and all reservoirs filled to operating level before the lathe is put into service!

Failure to comply may cause serious damage to the lathe!

- 1. Headstock**-Oil must be up to indicator mark in oil sight glass (A, Fig.3). Top off with Shell Turbo T-68 or equivalent. Fill by pulling plug (B, Fig.3). To drain, remove drain plug (A, Fig.4) with an 8mm hex wrench. Drain oil completely and refill after the first three months of operation. Then, change oil in the headstock annually.
- 2. Gearbox Input Shaft**-Remove end gear cover and oil the gearbox input shaft where it exits the headstock bracket (B, Fig.4) with the oil can using 20W machine oil. Oil once daily.
- 3. Gearbox**-Oil must be up to indicator mark in oil sight glass (C, Fig.3). Top off with Shell Turbo T-68 or equivalent. Fill by removing plug (C, Fig.4) with an 8mm hex wrench. To drain, remove drain plug (D, Fig.4) with an 8mm hex wrench. Drain oil completely and refill after the first three months of operation. Then, change oil in the gearbox annually.
- 4. Apron**-Oil must be up to indicator mark in oil sight glass (front of apron-A, Fig.5). Top off with Shell Turbo T-68 or equivalent. Remove oil cap (B, Fig.5) on top of apron to fill. To drain, remove drain plug on bottom of apron. Drain oil completely and refill after the first three months of operation. Then, change oil in the apron annually.
- 5. Leadscrew Feed Rod**-lubricate ball oiler (D, Fig.3) on leadscrew/feed rod bracket with 20W machine oil once daily.
- 6. Cross Slide**-Lubricate three oil ports (C, Fig.5) with 20W machine oil once daily.
- 7. Compound Rest**-lubricate one oil port (D, Fig.5) with 20W machine oil once daily.

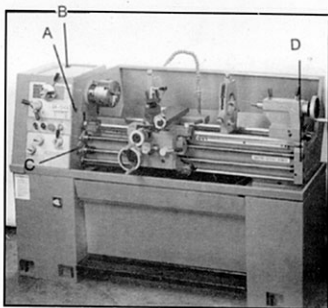

Fig.3

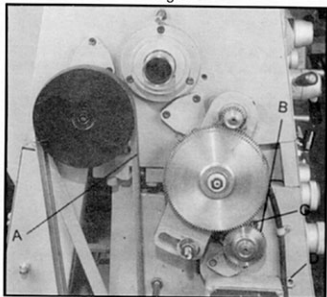

Fig.4

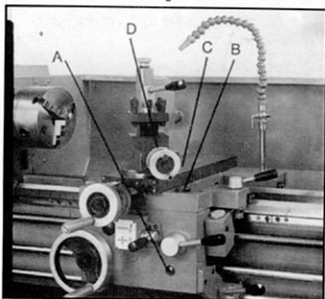

Fig.5

8. **Carriage**-lubricate four oil ports(A, Fig.6) with 20W machine oil once daily.
9. **Tailstock**-lubricate two oil port(B, Fig.6) with 20W machine oil once daily.

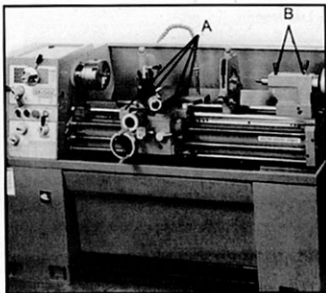

Fig.6

Coolant Preparation



CAUTION

Follow coolant manufacturer's recommendations for use, care, and disposal.

1. Remove rear access cover on tailstock end. Make sure coolant tank has not shifted during transport and is located properly under recovery chute.
2. Pour three gallons of coolant mix into drip pan.
3. After machine has been connected power, turn on coolant pump and check to see coolant is cycling properly.
4. Fasten coolant door to stand.

Electrical Connections



WARNING

All electrical connections must be completed by a qualified electrician!

Failure to comply may cause serious injury and/or damage to the machinery and property!

The GH-1340A gear head lathe is rated at 3HP. Confirm power available at the lathe's location is the same rating as the lathe.

Make sure the lathe is properly grounded.

Power is connected properly when pulling up on the forward-reverse lever causes the spindle to rotate counter-clockwise as viewed from the tailstock. If the chuck rotates in the clockwise direction, disconnect the lathe from the power source, switch two of three power leads, and connect the lathe to the power source.

General Description

Lathe Bed

The lathe bed(A, Fig.7) is made of high grade cast iron. By combining high cheeks with strong cross ribs, a bed with low vibration and high rigidity is realized. Two precision ground vee slideways, reinforced by heat hardening and grinding, are an accurate guide for the carriage and headstock. The main drive motor is mounted in the stand below headstock.

Headstock

The headstock (B, Fig.7) is cast from high grade, low vibration cast iron. It is bolted to the bed by four screws with two adjusting screws for alignment. In the head, the spindle is mounted on two precision taper roller bearings. The hollow spindle has Morse Taper # 5 with a 1-7/16" bore.

Carriage

The carriage(A, Fig.8) is made from high quality cast iron. The sliding parts are smooth ground. The cross-slide is mounted on the carriage and moves on a dovetailed slide which can be adjusted for play by means of the gibs.

The top slide(B, Fig.8), which is mounted on the cross slide (C, Fig.8), can be rotated through 360°. The top slide and the cross slide travel in a dovetail slide and have adjustable gibs. A four way tool post is fitted on the top slide.

Four Way Tool Post

The four way tool post(D, Fig.8) is mounted on the top slide and allows a maximum of four tools to be mounted simultaneously. Remember to use a minimum of two clamping screws when installing a cutting tool.

Apron

The apron(E, Fig.8) is mounted to the carriage. In the apron a half nut is fitted. The half nut gibs can be adjusted from the outside. The half nut is engaged by use of a lever. Quick travel of the apron is accomplished by means of a bed mounted rack and pinion, operated by a hand wheel on the front of the apron.

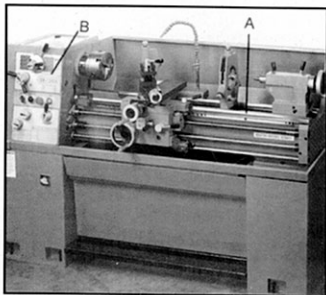

Fig.7

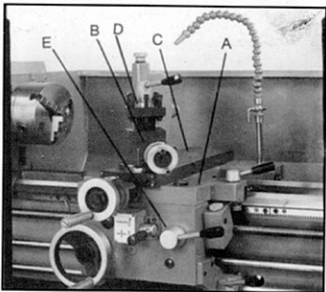

Fig.8

Tailstock

The tailstock(A, Fig.9) slides on a v-way and can be locked at any location by a clamping lever. The tailstock has a heavy duty spindle with a Morse Taper #3.

Leadscrew and Feed Rod

The leadscrew(B Fig. 9) and feed rod (C, Fig 9) are mounted on the front of the machine bed. They are connected to the gearbox at the left for automatic feed and lead and are supported by bushings on both ends. Both are equipped with brass shear pins.

Gear Box

The gear box(D, Fig.9) is made from high quality cast iron and is mounted to the left side of the machine bed.

Steady Rest

The steady rest (E, Fig.9) serves as a support for shafts on the free tailstock end. The steady rest is mounted on the bedway and secured from below with a bolt, nut and locking plate. The sliding fingers require continuous lubrication at the contact points with the workpiece to prevent premature wear. To set the steady rest:

1. Loosen three hex socket cap screws.
2. Loosen knurled screw and open sliding fingers until the steady rest can be moved with its fingers around the workpiece. Secure the steady rest in position.
3. Set the fingers snugly to the workpiece and secure by tightening three hex socket cap screws. Fingers should be snug but not overly tight. Lubricate sliding points with lead based grease.
4. After prolonged use, the fingers will show wear. Remill or file the tips of the fingers.

Follow Rest

The traveling follow rest(F, Fig.9) is mounted on the saddle and follows the movement of the turning tool. Only two fingers are required as the place of the third is taken by the turning tool. The follow rest is used for turning operations on long, slender

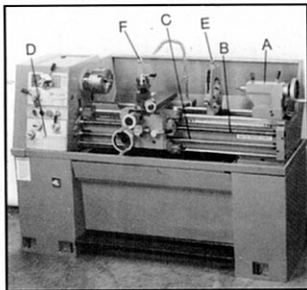

Fig.9

workpieces. It prevents flexing of the workpiece from the pressure of the cutting tool.

The sliding fingers are set similar to the steady rest, free of play, but not binding. Always lubricate adequately with lead based grease during operation.

Controls

1. **Control Panel**-located on front of headstock.

A.Coolant On-Off Switch (A, Fig. 10) turns coolant pump on and off.

B.Power Indicator Light (B, Fig. 10)-lit whenever later has power.

C.Emergency Stop Switch (C, Fig. 10)-depress to stop all machine functions. (Caution: lathe will still have power). Twist to re-set.

D.Jog Switch (D, Fig. 10)-depress and release to advance spindle momentarily.

2. **Headstock Gear Change Levers** (E, Fig. 10)-located on front of headstock at the top. Move levers left or right to desired spindle speed.

3. **Leadscrew/Feedrod Directional Lever** (F, Fig. 10)-located on front of headstock. Moving the lever up causes carriage travel toward the tailstock. Moving the lever down causes carriage travel toward the headstock. Do not move lever while machine is running.

4. **Feed/Lead Selector Lever** (G, Fig. 10)-located on the front of the headstock at the top. Used whenever setting up for threading or feeding. Caution: in the "A" position, never run the lathe higher than 770 RPM.

5. **Feed/Lead Selector Lever** (H, Fig. 10)-located on the front lower right corner of the headstock. Used in setting up for feeding and threading. Positions "F" and "D" are for the feed rod. Positions "E" and "C" are for the feed screw. Position "0" is neutral.

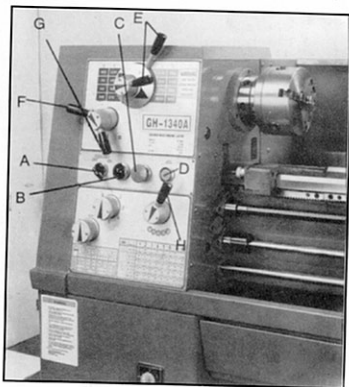

Fig.10

6. **Lock Knob**(A, Fig.11)-located on the front of the gearbox. With the lever in the six o'clock position, lead/feed selector knob (B, Fig.11) may be adjusted. With the lever in the twelve o'clock position, the lead/feed selector knob(B, Fig.11) is locked.
7. **Feed/Lead Selector Knob**(B, Fig.11)-located on front of the gearbox. Use for setting up for feeding and threading.
8. **Compound Lock**(A, Fig.12)-hex socket cap screw located on left side of compound rest. Turn clockwise to lock and counter-clockwise to unlock.
9. **Carriage Lock**(B, Fig.12)-lock handle located on top of carriage. Turn clockwise to lock. Turn counter-clockwise to unlock. **Caution:** carriage lock must be unlocked before engaging automatic feeds or damaged to lathe may occur.
10. **Cross Slide Lock**(C, Fig.12)-set screw located on right side of cross slide body. Turn clockwise and tighten to lock. Turn counter-clockwise and loosen to unlock. **Caution:** cross slide lock screw must be unlocked before engaging automatic feeds or damage to the lathe may occur.

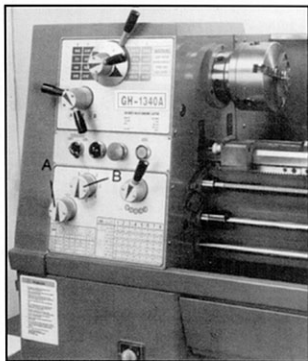

Fig.11

11. **Longitudinal Traverse Hand Wheel** (D, Fig.12)-located on the apron assembly. Rotate hand wheel clockwise to move the apron assembly toward the tailstock(right). Rotate the wheel counter-clockwise to move the apron assembly toward the headstock(left).
12. **Feed Selector**(E, Fig.12)-located in the center front of the apron assembly. Push lever to the left and down activates the crossfeed function. Pull lever to the right and up activates the longitudinal function.
13. **Half Nut Engage Lever(Threading)** (F, Fig.12)-located on front of the apron. Move the lever down to engage. Move the lever up to disengage.
14. **Cross Traverse Handwheel**(G, Fig.12)- located above the apron-assembly. Clockwise rotation moves the cross slide toward the rear of the machine.

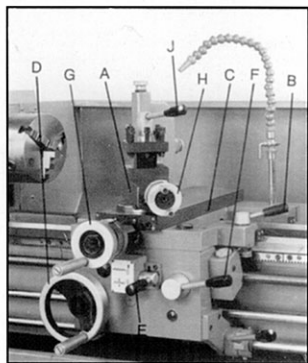

Fig.12

15. **Compound Rest Traverse Handwheel** (H, Fig. 12)- located on the end of the compound slide. Rotate clockwise or counter-clockwise to move or position.
16. **Tool Post Clamping Lever** (J, Fig. 12) - located on top of the toolpost. Rotate counter-clockwise to loosen and clockwise to tighten.
17. **Tailstock Quill Clamping Lever** (A, Fig. 13) - located on the tailstock. Lift up to lock the spindle. Push down to unlock.
18. **Tailstock Clamping Lever** (B, Fig. 13)- located on the tailstock. Lift up lever to lock. Push down lever to unlock.
19. **Tistock Quill Traverse Handwheel** (c, Fig. 13) - located on the tailstock. Rotate clockwise to advance the quill. Rotate counter-clockwise to retract the quill.
20. **Tailstock Off-Set Adjustment** (D, Fig. 13) - two hex socket cap screws located on the tailstock base are used to off-set the tailstock for cutting tapers. Loosening one screw while tightening the other off sets the tailstock.

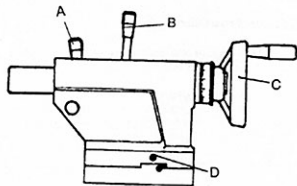

Fig.13

21. **Foot Brake** (A, Fig. 14)- located between stand pedestals. Dwpres to stop all lathe functions.
22. **Power Switch** (not shown) - located on the electrical box on the rear of the lathe. Turns main power to the lathe on and off.
23. **Two Speed Motor Switch** (B, Fig. 14) located on front of the left base pedestal. Position one is for high speed. Position two is for low speed. Position zero is neutral and the spindle will not turn. **Note:** Check this switch and make sure position one or two is selected if the lathe will not run.
24. **Micro Carriage Stop** (A, Fig. 15) - located on the lathe bed. Loosen two hex socket cap screws underneath body and slide along bed to desired position. Tighten screw to hold in place.

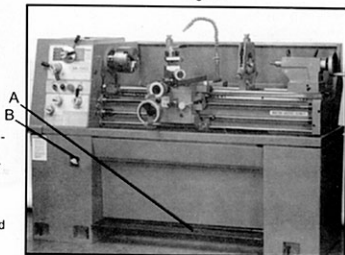

Fig.14

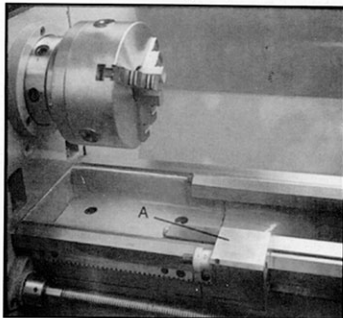

Fig.15

Break-In Procedure

During manufacture and testing, this lathe has been operated in the low R.P.M. range for three hours.

To allow time for the gears and bearings to break-in and run smoothly, do not run the lathe above 770 R.P.M. for the first six hours of operation and use.

Operation

Feed and Thread Selection

1. Reference the feed and thread tables (A, Fig. 16) found on the gear box faceplate.
2. Move levers (B, C, D, & E, Fig. 16) to the appropriate positions according to the chart.

Change Gears Replacement

Note: the 25T x 127T x 50T gears are installed in the end gear compartment when delivered from the factory. This combination will cover most inch feeds and threads under normal circumstances. The 30, 32, two 40 tooth gears and other gears found in the tool box are used as indicated on feed and thread tables (A, Fig. 16).

1. Disconnect the machine from the power source.
2. Remove the end cover on the left end of the headstock.
3. Loosen nuts (A & B, Fig. 17).
4. Move quadrant (C, Fig. 17) out of the way and hold in place temporarily by tightening nut (B, Fig. 17).
5. Remove hex socket cap screws (D and/or E, Fig. 17), depending on which gear is to be changed.
6. Install new gear(s) and tighten in place with a hex socket cap screw.
7. Loosen nut (B, Fig. 17), move quadrant back so teeth mesh on gears, and tighten nuts (A & B, Fig. 17). **Caution: Make sure there is a backlash of .002"-.003" between gears, Setting the gears too tight will cause excessive noise and wear.**

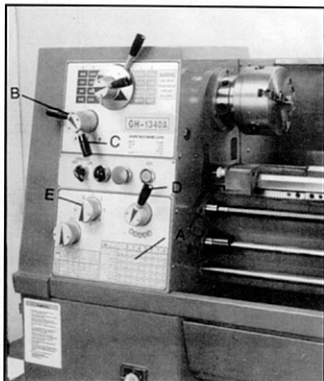

Fig.16

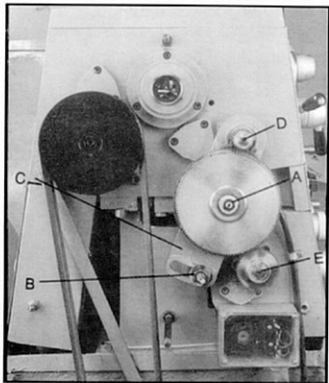

Fig.17

7. Install the cover and connect the machine to the power source.

Note: other gear combinations are possible. See the lead and feed chart on the front of the gear box (A, Fig. 16).

Automatic Feed Operation and Feed Changes

1. Move the forward/reverse selector (A, Fig. 18) up or down depending on desired direction.
2. Set selector levers (A,B,C,&D, Fig. 19) to desired rate. **Note:** for feeding, lever (C) will be set at "F" or "D", depending on desired feed rate.

Powered Carriage Travel

1. Push lever (B, Fig. 18) to the left and down to engage crossfeed. Pull lever to the right and up to engage longitudinal feed.

Thread Cutting

1. Set forward/reverse lever (A, Fig. 19) up or down depending on the desired direction.
2. Set selector levers (A,B,C, and D, Fig. 19) to desired rate. **Note:** for threading, lever (C) will be set at "C" or "E", depending on desired thread.
3. Engage the half nut lever (C, Fig. 18).
4. To cut inch threads, refer to the chart on page 16. The half nut lever and the threading dial are used to thread in the conventional manner. The thread dial chart specifies at which point a thread can be entered using the threading dial.
5. To cut metric threads, the half nuts must be left continually engaged once the start point has been selected and the half nut is initially engaged (thread dial cannot be used).

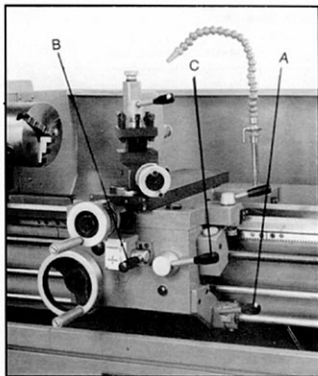

Fig. 18

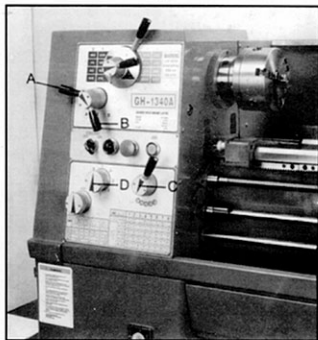

Fig. 19

Inch Gear Box:

Metric Thread Table

MM →	127		50		127		50		45	
	120	40	120	50	120	50	120	60		
	1	3	6	3	1	2	3			
AC	7.5	6.0	5.0	4.8	4.5	4.0				
BC	3.75	3.0	2.5	2.4	2.25	2.0	1.8			
AE		1.5	1.25	1.2		1.0	0.9			
BE		0.75		0.6		0.5	0.45			

Inch Lead and Feed Table

T.P.I.		IN		1	2	3	4	5	6	7	8
127 50	A	C	4	4 1/2	5	5 1/2	5 3/4	6	6 1/2	7	
	D		.0294	.0261	.0235	.0214	.0205	.0196	.0181	.0168	
127 50	A	C	8	9	10	11	11 1/2	12	13	14	
	D		.0147	.0131	.0117	.0107	.0102	.0098	.0090	.0084	
127 50	B	C	16	18	20	22	23	24	26	28	
	D		.0073	.0065	.0058	.0053	.0051	.0049	.0045	.0042	
127 50	A	E	32	36	40	44	46	48	52	56	
	F		.0042	.0038	.0034	.0031	.0030	.0028	.0026	.0024	
127 50	B	E	64	72	80	88	92	96	104	112	
	F		.0021	.0019	.0017	.0015	.0015	.0014	.0013	.0012	

Metric Gear Box :

MM		MM		MM		MM		MM		MM		T.P.I.																
30T	60T	1	2	3	4	6	7	8	1	2	3	4	6	7	8	2	1	2	2	1	1	1						
C	A	4.0	4.5	5.0	5.5	6.0	6.5	7.0	D	A	0.375	0.428	0.486	0.513	0.561	0.606	0.653	E	A	40	40	32	32	30	30	30		
	B	2.0	2.25	2.5	2.75	3.0	3.25	3.5	B	B	0.188	0.214	0.233	0.256	0.280	0.303	0.327		B	60	60	60	66	60	65	70		
E	A	1.0	1.125	1.25	1.375	1.5	1.625	1.75	F	A	0.109	0.122	0.135	0.149	0.163	0.177	0.190	F	C	A	4	4 1/2	5	5 1/2	6	6 1/2	7	
	B	0.5		0.625		0.75		0.875	B	B	0.054	0.060	0.067	0.074	0.081	0.088	0.095		B	8	9	10	11	12	13	14		
24T	60T	A	0.8	0.9	1.0	1.1	1.2	1.3	1.4	F	A	0.087	0.096	0.109	0.119	0.131	0.141	0.152	F	E	A	16	18	20	22	24	26	28
		B	0.4	0.45	0.5	0.55	0.6	0.65	0.7	B	B	0.043	0.049	0.054	0.059	0.065	0.071	0.076		B	32	36	40	44	48	52	56	

Compound Rest

The compound rest (A, Fig. 20) is located on top of the carriage and can be rotated 360 degrees. There is a calibrated dial (in degrees) (B, Fig. 20) below the rest to assist in placement of the compound to the desired angle.

Adjustments

After a period of time, wear in some of the moving components may need to be adjusted:

Saddle

1. Loosen four hex nuts found on the bottom rear of the cross slide and back off one full turn each
2. Turn each of the four set screws with a hex wrench until a slight resistance is felt. Do not over tighten these screws.

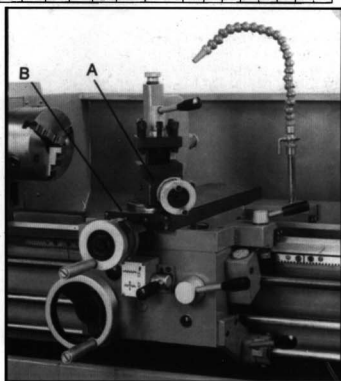

Fig.20

3. Move the carriage with the hand wheel and determine if the drag is to your preference. Readjust the set screws as necessary to achieve the desired drag.
4. Hold the socked set screw firmly with a hex wrench and tighten the hex nut to lock the set screw in place.
5. Move the carriage again and adjust again if necessary. **Note:** over adjustment will cause excessive premature wear of the gibs.

Cross Slide

If the cross slide is too loose, follow procedure below to tighten:

1. Loosen the rear gib screw approximately one turn.
2. Tighten the front gib screw (B, Fig. 21) a quarter turn. Turn the cross slide handwheel to see if the cross slide is still loose. If it is still loose, tighten the front screw a bit more and try again.
3. When the cross slide is properly adjusted, tighten the rear gib screw. Do not over tighten. This will cause premature wear on the gib and mating parts.

Compound Rest

Follow the same procedure as the cross slide adjustment to adjust the compound rest. Rear gib screw (B) is shown in Fig. 21. **Note:** the front handwheel on the compound will have to be removed to access the front gib screw.

Tailstock

If the handle will not lock the tailstock, follow the procedure below:

1. Lower the handle to the unlocked position.
2. Slide the tailstock to an area that allows access to the underside of the tailstock.
3. Tighten tailstock clamping bolt 1/4 turn. Test for proper locking. Repeat as necessary.

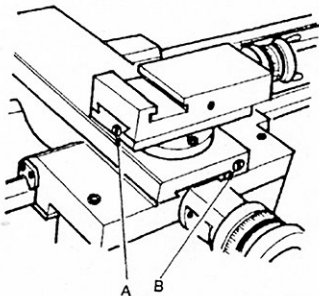

Fig.21

Tailstock Off-Set

Follow the procedure below to off-set the tailstock to cut shallow tapers:

1. Lock tailstock in position by raising locking handle(A, Fig.22)
2. Alternately loosen and tighten front and rear hex socket cap screws(B, Fig.22).

Tailstock Gibs

Take up play in the tailstock by tightening two gib screws(C, Fig.22) on either side of the tailstock base. Note: Do not over tighten. Excessive tightening will lead premature wear of the gibs and mating parts.

Headstock Alignment

The headstock has been aligned at the factory and should not require adjustment. However, if adjustment is deemed necessary, follow the procedure below to align the headstock:

1. Using a machinist's precision level on the bedways, make sure the lathe is level side to side and front to back. If the lathe is not level, correct to a level condition before proceeding. Re-test alignment if any leveling adjustments were made.
2. From steel bar stock of approximately two inches in diameter, cut a piece approximately eight inches long.
3. Place two inches of bar stock into chuck and tighten chuck. Do not use the tailstock or center to support the other end.
4. Set up and cut along five inches of the bar stock.
5. Using a micrometer, measure the bar stock neck to the chuck and at the end. The measurement should be the same.
6. If the measurements are not the same and adjustment is required, loosen hex socket cap screws(A, Fig.23) which hold the headstock to the bed. Do not loosen completely; some drag should remain.

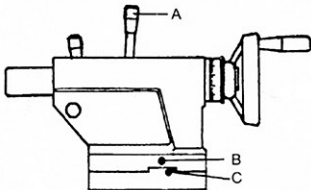

Fig.22

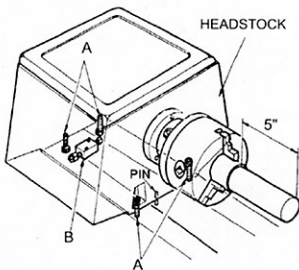

Fig.23

- Adjust two screw nuts (B, Fig. 24) located on the endgear side of the headstock. Loosen one and tighten the other. Make another cut. Keep adjusting screw nuts after each cut until the bar stock measurements are the same. Tighten all headstock screws.

Removing Gap Section

- To remove gap section, locate two nuts (A, Fig. 25) in the center of the gap section.
- Using an open end wrench, tighten the two nuts. This will cause the taper pins to release. Remove the taper pins.
- Remove six hex socket cap screws (B, Fig. 25) with a hex key wrench.
- Gap section can now be removed.

Installing Removable Gap Section

- Clean the bottom and the ends of the gap section thoroughly.
- Set gap section in place and align.
- Remove nuts from the taper pins.
- Slide taper pins in their respective holes and seat using a mallet. Install nuts on the taper pins finger tight.
- Install four socket head cap screws and tighten securely.

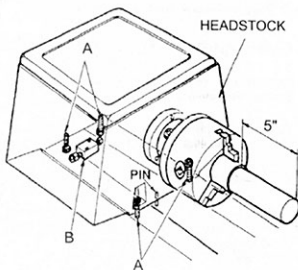

Fig.24

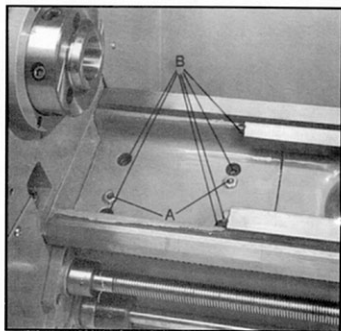

Fig.25

Belt Replacement and Adjustment

1. Disconnect machine from the power source.
2. Remove end gear cover and lower rear cover on the headstock side.
3. Take tension off old belts by loosening two motor mount plate screws(A, Fig.26).
4. Remove belts. Install new belts onto pulleys.
5. Tension by tightening motor mount plate screws until light finger pressure causes approximately 3/4" deflection on each belt.
6. Install covers and connect lathe to the power source.

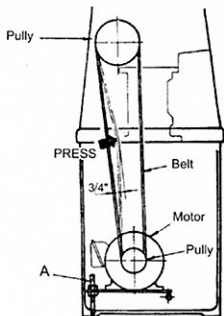

Fig.26

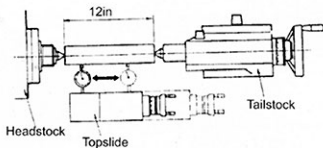

Fig.27

Aligning Tailstock to Headstock

Before proceeding, headstock should be aligned. See section labeled "Headstock Alignment".

1. Fit a 12" ground steel bar between centers of the headstock and tailstock. (See Fig.27)
2. Fit a dial indicator to the top slide and traverse the center line of the bar.
3. If adjustment is needed, align the tailstock using the off set screws(A, Fig.28) until the tailstock is aligned.

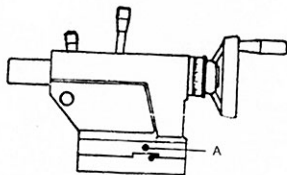

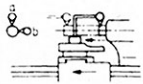
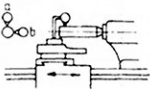
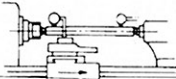

Fig.28

Light Load Lathe

Test Record

Model NO.: R06236x1000
Serial NO.: 0860503

NO.	INSPECTION ITEM		DIAGRAM	TOLERANCE	
				PERMISSIBLE	ACTUAL
1.	Straightness of bedways	a. Longitudinal direction (In vertical plane)		0.0008" (0.02 mm)	0.018
		b. Transverse direction (In vertical plane)		0.0016" IN 40" (0.04mm)	
2.	Parallelism of bedways			0.0008" (0.02 mm)	0.015
3.	Spindle nose runout			0.0004" (0.01mm)	0.006
4.	Spindle taper hole runout	a. At or near spindle nose		0.0004" (0.01mm)	0.005
		b. 12" from spindle nose		0.0008" (0.02mm)	0.014
5.	Parallelism of center line of main spindle to longitudinal motion of carriage	a. In vertical plane (Free end rising)		0.0008" IN 12" (0.02mm)	0.016
		b. In horizontal plane (Directed towards headstock)		0.0006" IN 12" (0.015mm)	
6.	Movement of compound slide parallel with main spindle in vertical plane (Hand feed)			0.0016" IN 12" (0.04mm)	0.026
7.	Main spindle for axial slip, measured at 2 points, displaced by 180			0.0006" (0.015mm)	0.012
8.	True running of center point of main spindle			0.0006" (0.015mm)	0.013

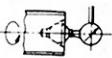
9.	Parallelism of tailstock quill with bedways	a. In vertical plane (free end rising)		0.0008"IN4" (0.02mm)	0.015
		b. In horizontal plane (Front end inclined towards the direction of tool pressure)		0.0006"IN4" (0.015mm)	0.006
10.	Parallelism of bedways with center line of tailstock spindle hole	a. In vertical plane (free end rising)		0.0012"IN12" (0.03mm)	0.021
		b. In horizontal plane (Front end inclined towards the direction of tool pressure)		0.0012"IN12" (0.03mm)	0.022
11.	Difference in center height between headstock and tailstock (Mandrel rising towards tailstock end)		0.0016"IN12" (0.04mm)	0.037	
12.	Squareness of motion of cross slide with center line of main spindle		0.0008"IN8" (0.02mm)	0.015	
13.	Axial displacement of leadscrew by turning		0.0006" (0.015mm)	0.009	

PRACTICAL

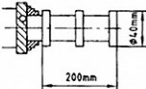
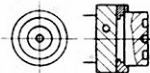
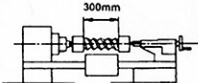
NO.	INSPECTION ITEM	DIAGRAM	TOLERANCE	
			PERMISSIBLE	ACTUAL
1.	Accuracy of outside turning		0.0004" (0.01mm)	0.006
	Accuracy of cylindrical turning (Material: Steels)		0.0008" (0.02mm)	0.015
2.	Accuracy of face turning (Material: Casting Iron or Brass)		0.0008" IN 8" (0.02mm)	0.018
3.	Accuracy of thread turning (Material: Steels)		0.0023" IN 12" (0.06/300mm) 0.001" IN 2" (0.025/50mm)	0.056 0.023

Inspecting engineer:

Date: