

SIMONET + CO. LTD
MACHINE TOOL WORKS
4500 SOLEURE
(SWITZERLAND)

SIMONET



Precision
screw cutting lathe

DZ-450

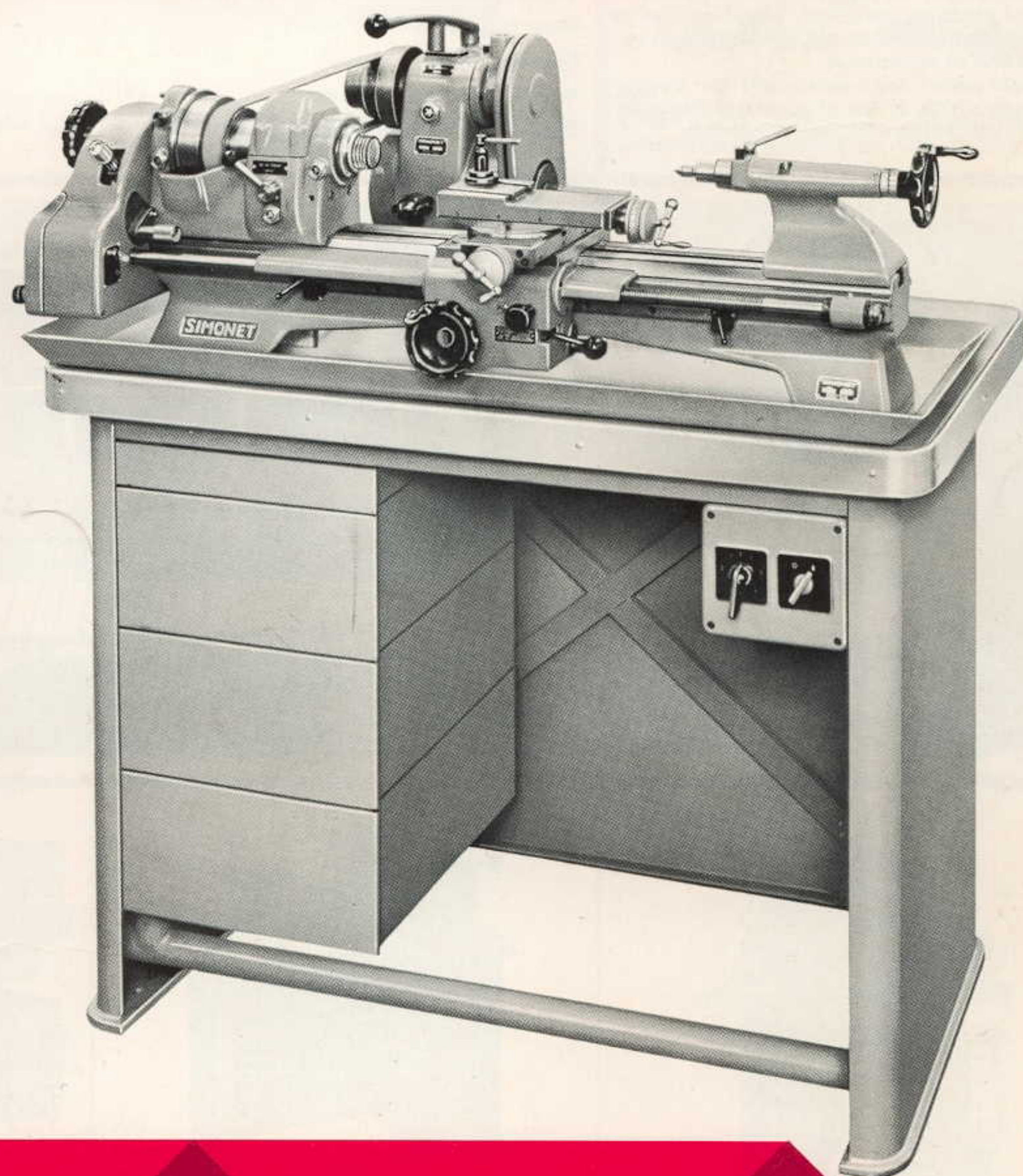

Precision screw cutting lathe

DZ-450

Simonet lathes – built on the unit construction principle

DC-102 tool maker's lathe
DZ-450 screw cutting lathe

These two types are mainly intended for the precision machining of single parts or small batches of parts. They ensure a wide field of application: tool room, laboratory, repair shop, assembly shop.

Production runs and second-setting machining are performed on the

DR-102 capstan lathe
DDA-102 semi-automatic second-operation lathe
DRA-102 automatic capstan lathe } camless

Universal interchangeability of the units (headstocks, crosswise arranged slides, etc.) and a large number of accessories and attachments (clamping elements, grinding and milling attachments, etc.) are the distinguishing features of these precision machines. Thus they can be quickly adapted to deal economically with various kinds of workpieces.

On these lathes small-sized parts can be machined to a high degree of accuracy. The automatic types permit high rate production.

Specifications

Screw cutting lathe DZ-450

Height of centres		4"
Distance between centres		18"
Swing over slide		5 1/8"
Headstock with reduction gear		1:5
Collets W 20: Shank diameter		20 mm
Range of diameters passing through shank		1/32" to 9/16"
Range of diameters not passing through shank		5/8" to 3/4"
Fine feed reduction gear		1:4
Thread pitches	Number 29 British threads/1"	5 to 112
	Number 24 metric mm	0.05 to 4
Longitudinal feeds		.00075" to .05"
Travel of longitudinal slide		4 3/4"
Travel of transverse slide		4 3/4"
Travel of tailstock sleeve		2 3/4"
Inner taper of tailstock sleeve		Morse 1
Spindle speeds	r.p.m.	14–2750
Weight with bench and drive		685 lbs
Space required with bench and drive	length/breadth/height	53" x 35" x 50"

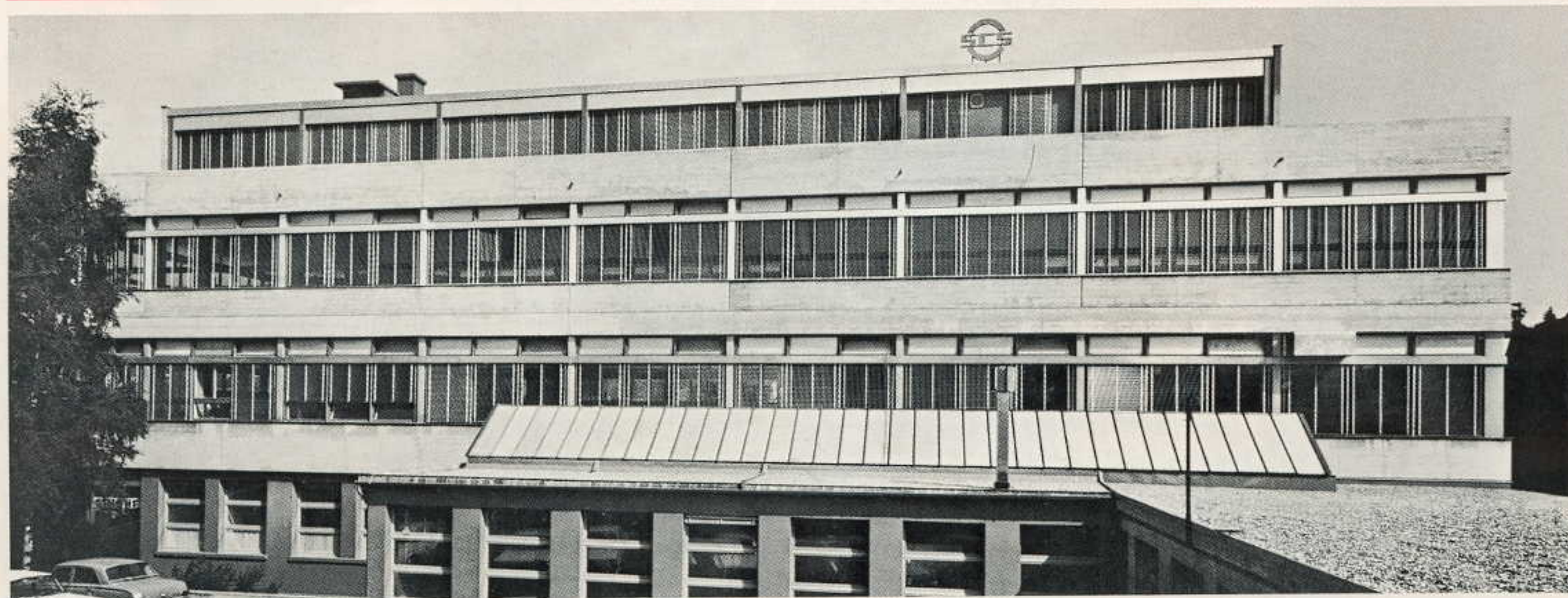

Semi-automatic second-operation lathe DDA-102



Tool maker's lathe DC-102

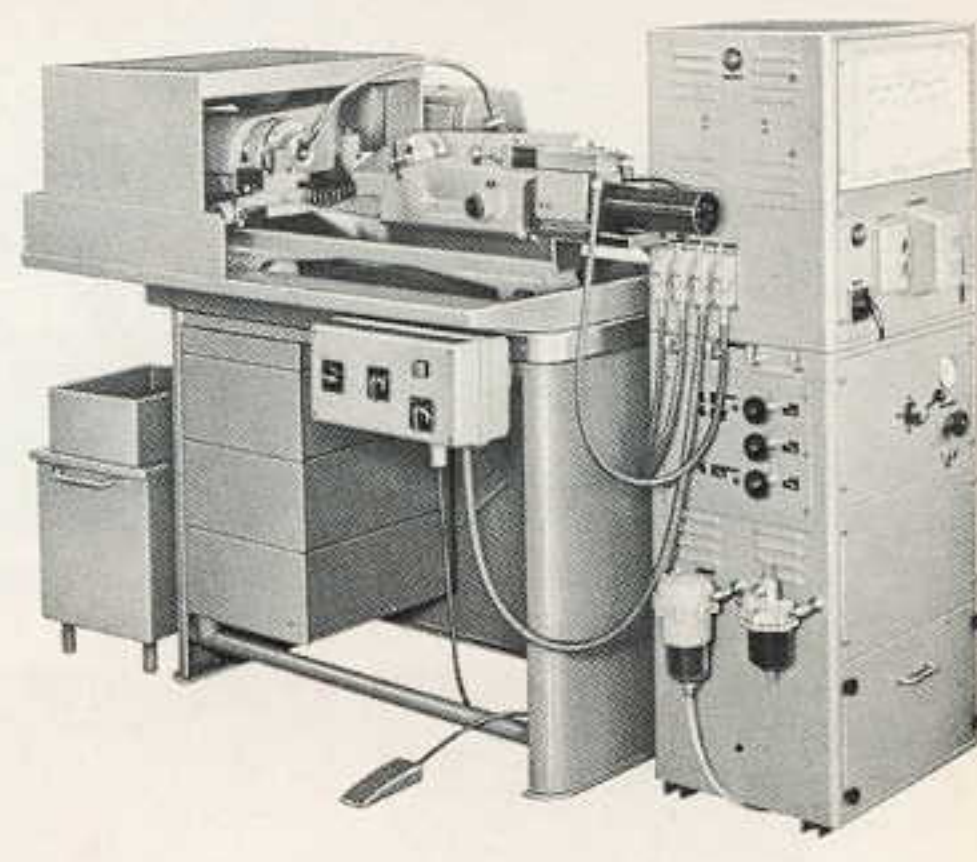

Automatic capstan lathe DRA-102

SIMONET + CO. LTD
MACHINE TOOL WORKS
4500 SOLEURE/SWITZERLAND
PHONE 065/277 21
TELEX 34 623

SIMONET



**Precision
screw cutting lathe**

DZ-450

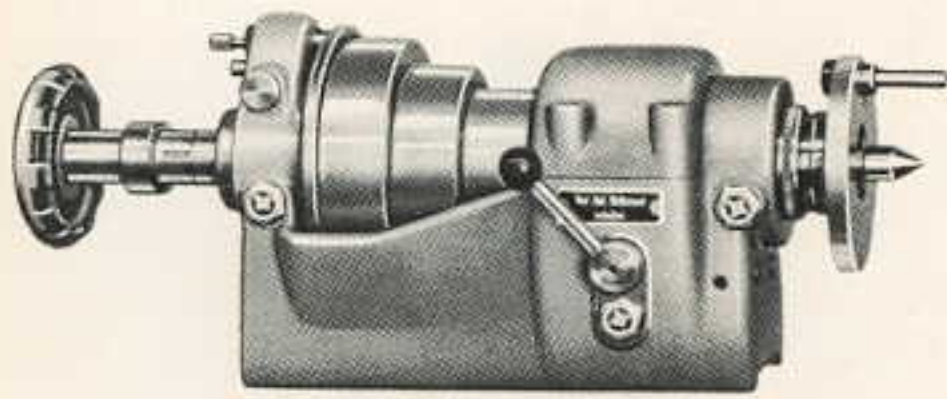

214
Headstock with reduction gear (1:5) for collets W 20 shank dia. 20 mm, with special plain bearings for speeds up to 2500 r.p.m., gear running in oil bath

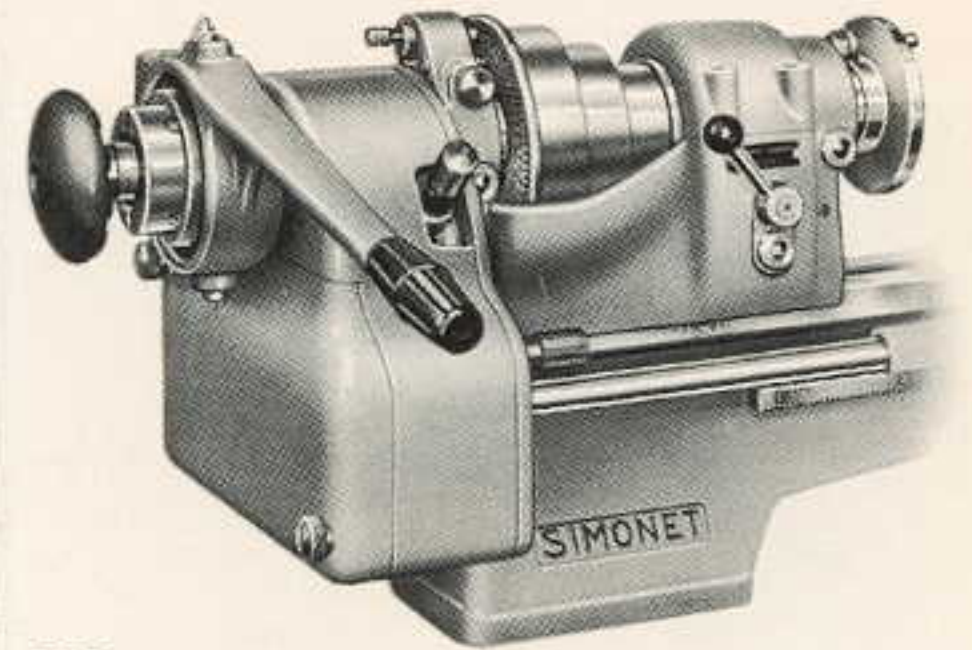

518
Lever-operated quick closing attachment, for collets type W 20, fits on headstock No.214 with reduction gear and change gear box



150
Collets W 20, shank dia. 20 mm, range of dia. passing through $\frac{1}{32}$ – $\frac{9}{16}$ " , range of dia. not passing through $\frac{5}{8}$ – $\frac{3}{4}$ "

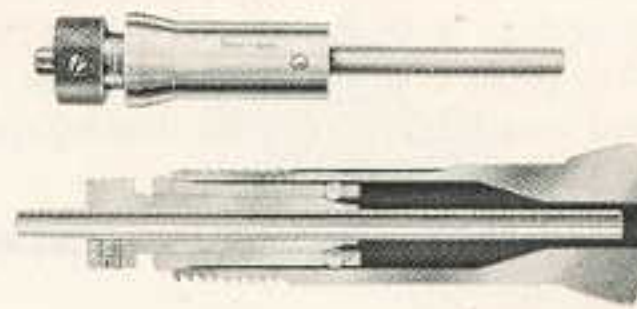

142
Stop for adjustment of depth for collets W 20, maximum depth 2"

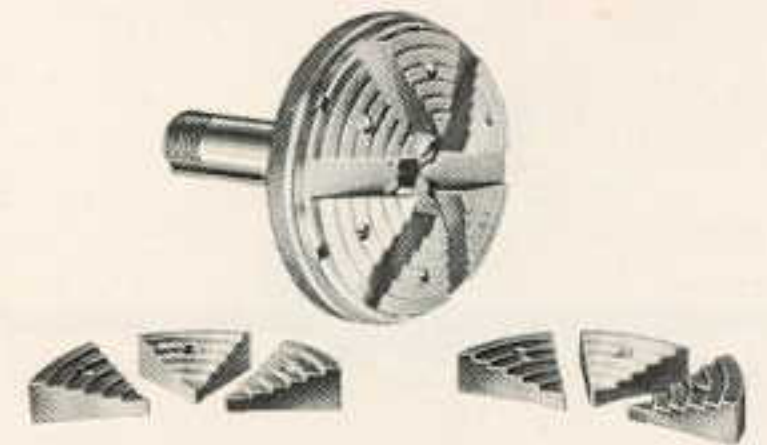

225
Chuck 4" dia., with shank W 20, and 6 jaws for internal gripping and 6 for external



155
Internal step collet blank 2" dia. without steps, shank W 20

156
Internal step collet blank 3" dia. without steps, shank W 20

157
Internal step collet blank 4" dia. without steps, shank W 20

158
Clamping cone for collets No. 155, 156 and 157



165
External step collet blank 2" dia. without steps, shank W 20

166
External step collet blank 3" dia. without steps, shank W 20

167
External step collet blank 4" dia. without steps, shank W 20

168
External step collet blank 5" dia. without steps, shank W 20



169
Closing cone for external step collet No. 165

170
Closing cone for external step collet No. 166

171
Closing cone for external step collets No.167 and 168

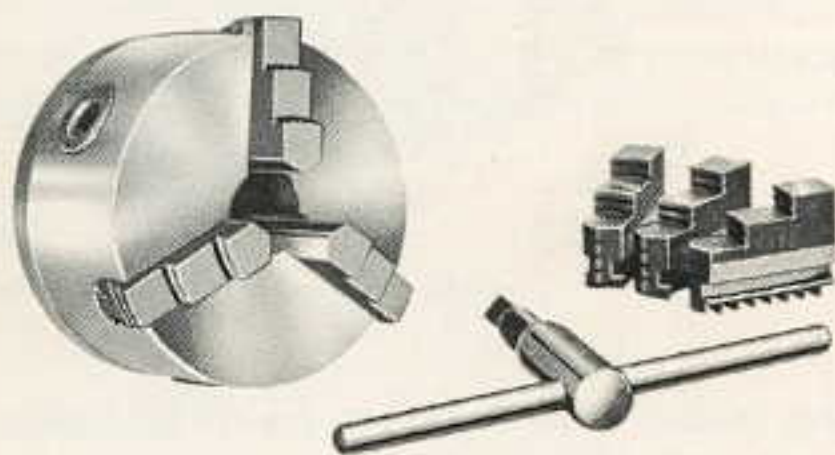

227
Three-jaw s.c. chuck, 4 $\frac{3}{8}$ " dia., fitted on backplate, with 3 turning and 3 drilling jaws

226
Four-jaw s.c. chuck, 4 $\frac{3}{8}$ " dia., fitted on backplate, with 4 turning and 4 drilling jaws



222
Permanent magnetic chuck 4" dia., fitted on backplate

223
Permanent magnetic chuck 6" dia., fitted on backplate

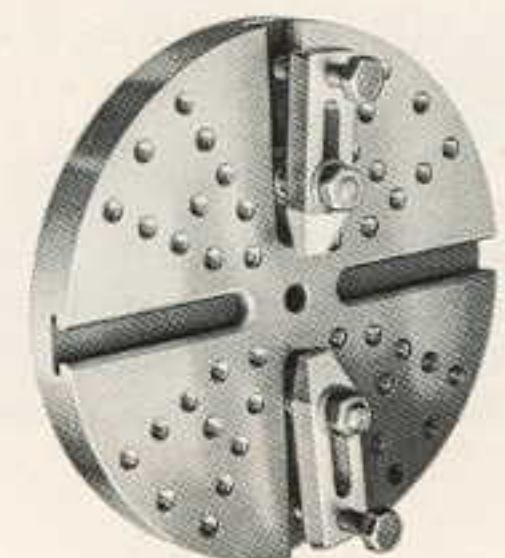

230
Face plate 7 $\frac{1}{2}$ " dia. with 4 T-slots and tapped holes, including 2 clamping dogs

SIMONET + CO. LTD
MACHINE TOOL WORKS
4500 SOLEURE/SWITZERLAND
PHONE 065/27721
TELEX 34623

SIMONET



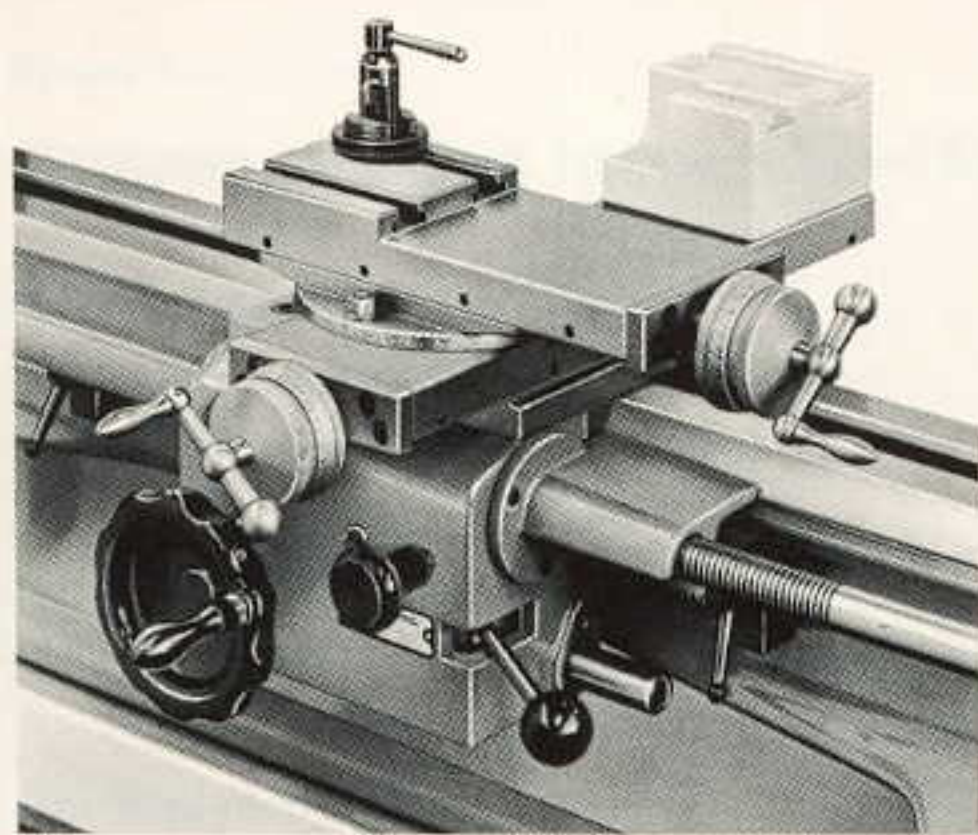

510

Bed surface-hardened and ground, length 39", change gear box with fine feed reduction gear (ratio 1:4), pick-off gears, apron for thread cutting and turning, automatic disengagement, crosswise arranged slides



319

Fixed toolholder support for the back

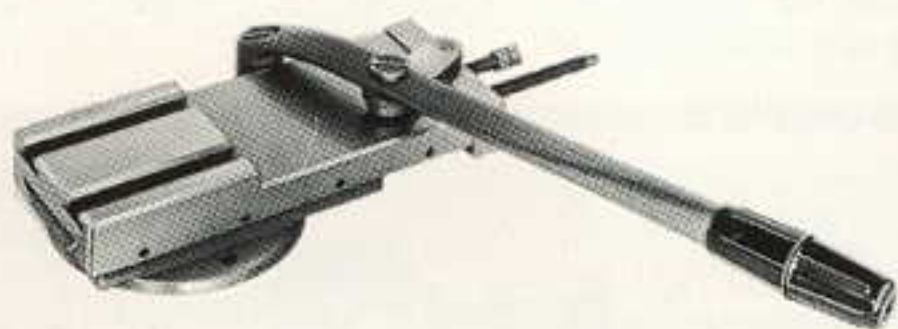

272

Lever operated longitudinal slide, interchangeable, with 2 adjustable stops, slide travel $3\frac{9}{16}$ "



274

Rear interchangeable slide, with screw for longitudinal movement, travel 2"

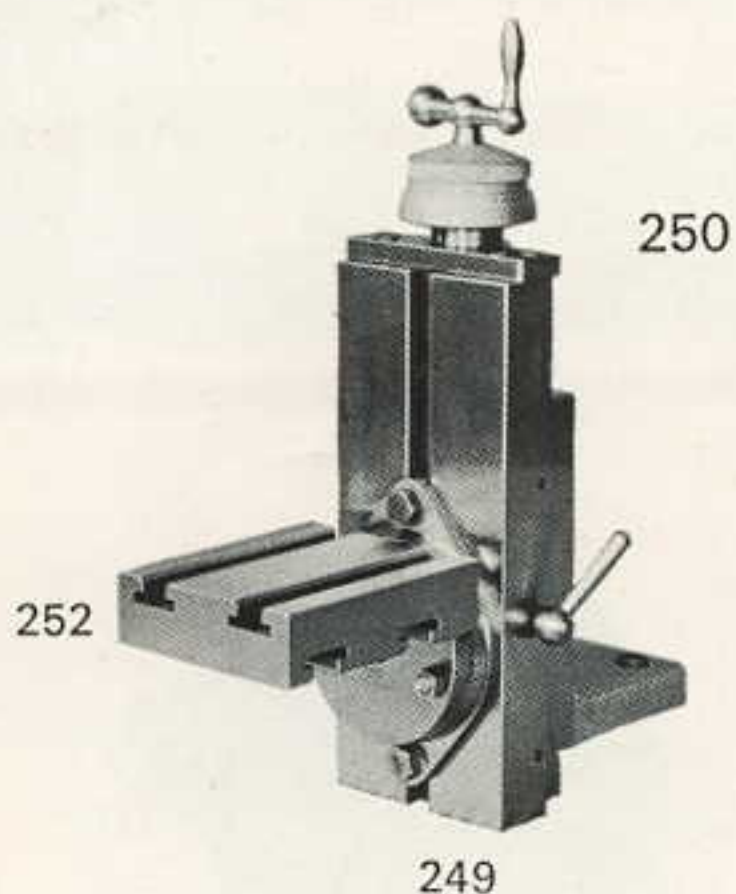

249

Base plate with graduation in degrees

250

Vertical slide, slide travel $4\frac{3}{4}$ "

252

Angle plate with 2 clamping surfaces $3\frac{1}{2}$ " x $3\frac{1}{2}$ "

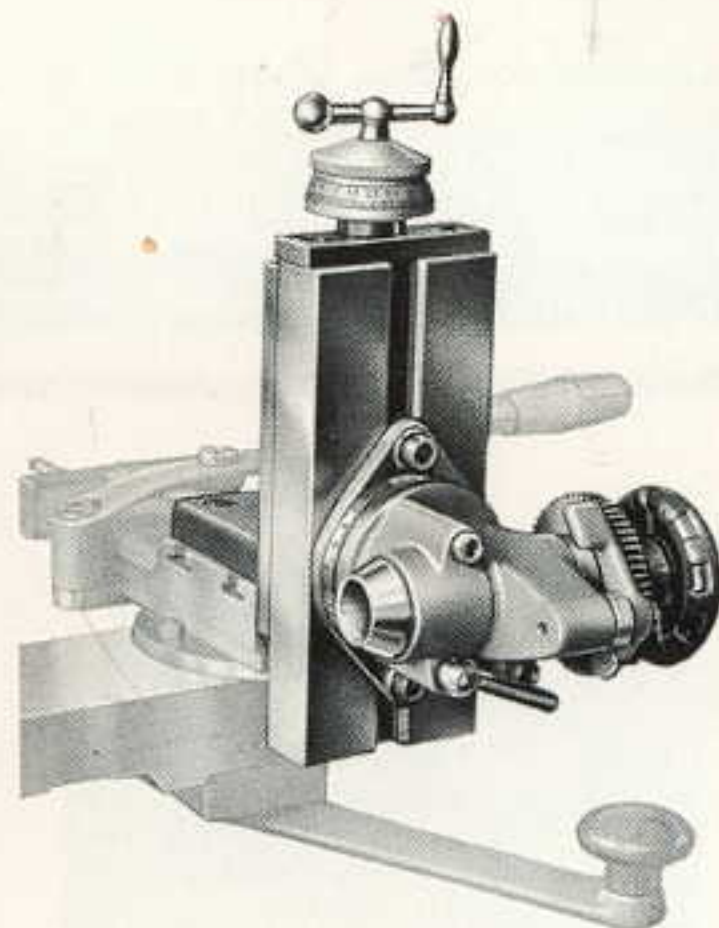

251

Dividing head for vertical slide, for W 20 collets, incl. 3 indexing wheels with 48, 60 and 100 teeth

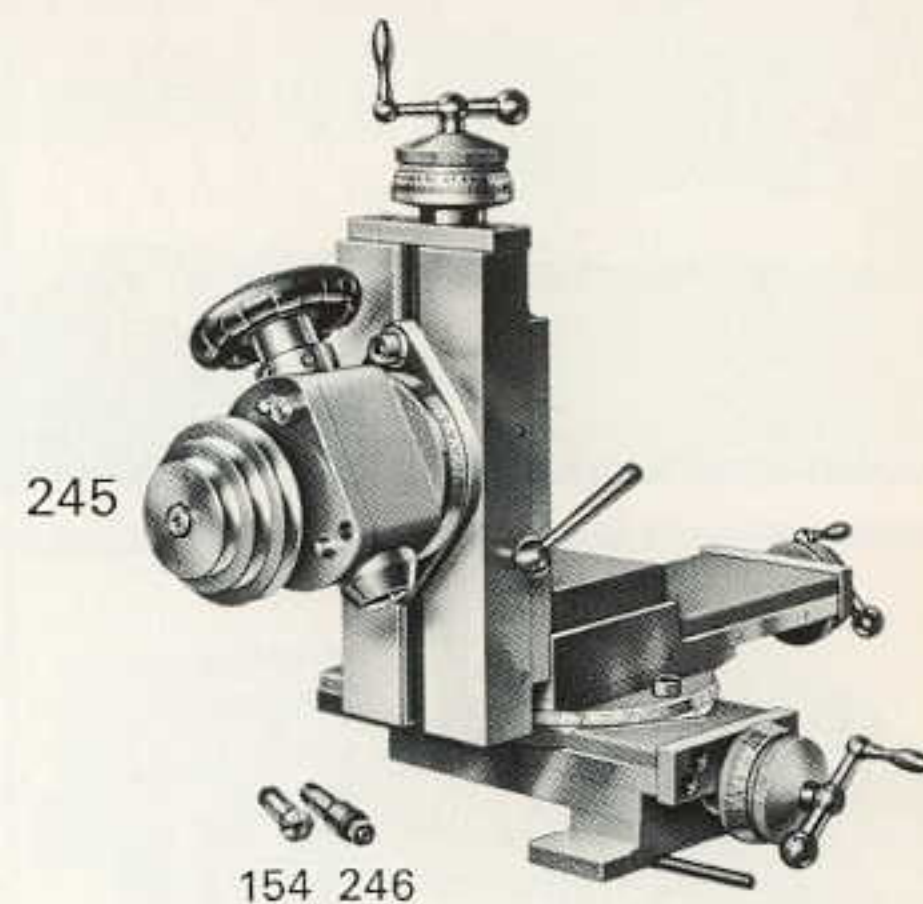

245

Milling head, with drawbar for W 12 collets, cutter speeds 480-3000 r.p.m.

246

Cutter arbors 6, 8, 10 and 13 mm dia., shank type W 12

154

Collets W 12, shank dia. 12 mm, range of dia. passing through $\frac{1}{32}$ - $\frac{5}{16}$ ", range of dia. not passing through $\frac{3}{8}$ - $\frac{1}{2}$ "

**Precision
screw cutting lathe**

DZ-450



290
Toolpost



291
Toolpost with 2 screws

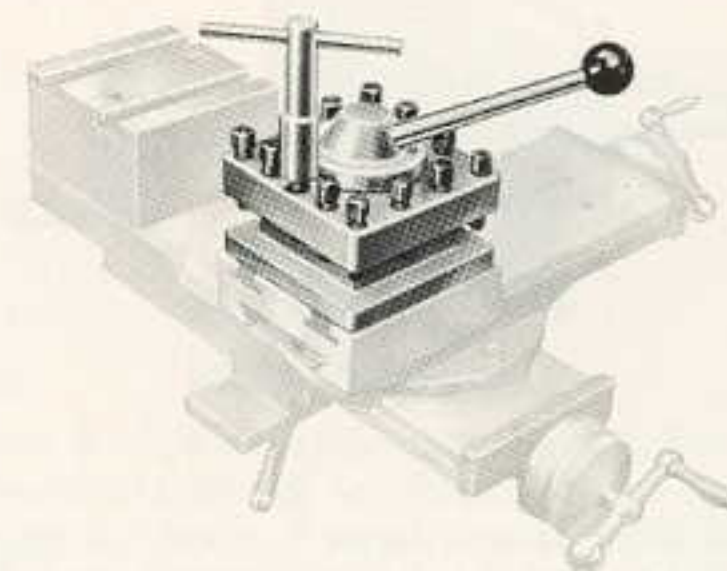

288
Four-way tool post for tools $\frac{3}{8}$ " x $\frac{3}{8}$ "



283
Toolholder right-sided for tools $\frac{3}{8}$ " x $\frac{3}{8}$ "



285/111
Quick-change tool post, without toolholders

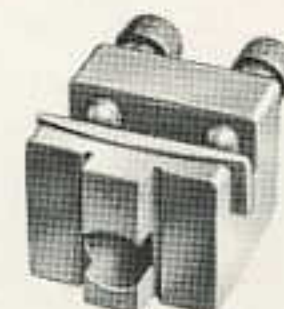

287
Simple block toolholder for tools $\frac{3}{8}$ " x $\frac{3}{8}$ "



284
Toolholder left-sided for tools $\frac{3}{8}$ " x $\frac{3}{8}$ "



285/131
Toolholder for tools $\frac{3}{8}$ " x $\frac{3}{8}$ "



296
Set of 7 internal turning tools, of high-speed steel, with V-block



235
Grinding attachment running in adjustable precision taper roller bearings, can be regulated in height, with drawbar for B 8 collets, maximum spindle speed 20 000 r.p.m.



285/131b
Toolholder with prism for tools $\frac{3}{8}$ " x $\frac{3}{8}$ "



285/132
Double toolholder for tools $\frac{3}{8}$ " x $\frac{3}{8}$ "

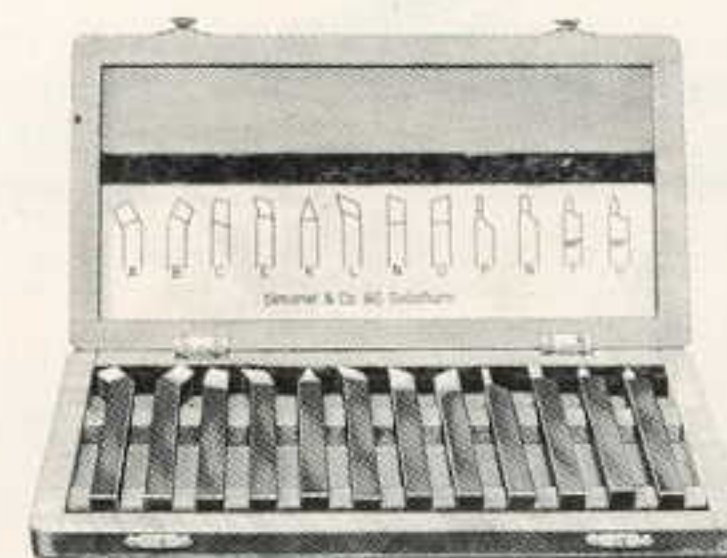

294
Set of 12 external turning tools of high-speed steel

236
Insert for external grinding



153
Collets B 8, shank dia. 8 mm, range of dia. passing through $\frac{1}{32}$ " - $\frac{3}{16}$ ", range of dia. not passing through $\frac{13}{64}$ " - $\frac{5}{16}$ "



285/134
Cutting-off toolholder for tools $\frac{3}{8}$ " x $\frac{3}{8}$ "

295
Set of 10 external turning tools tipped with carbide

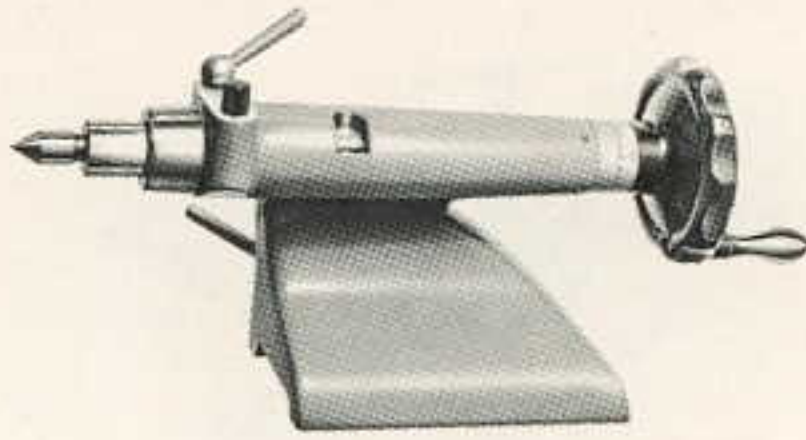

218
Tailstock with Morse taper 1, travel of spindle sleeve 2³/₄" , with 1/16" graduations along the spindle sleeve



100
Tailstock centre with Morse taper 1



102
Tailstock carbide centre with Morse taper 1



101
Half centre with Morse taper 1



104
Hollow centre with Morse taper 1



105
Half hollow centre with Morse taper 1



106
Drilling fork with Morse taper 1



107
Half drilling fork with Morse taper 1



108
Drilling plate dia. 2" with Morse taper 1



110
Drill chuck with Morse taper 1, capacity 1/32" to 3/8"

111
Keyless drill chuck with Morse taper 1, capacity 1/32" - 3/8"

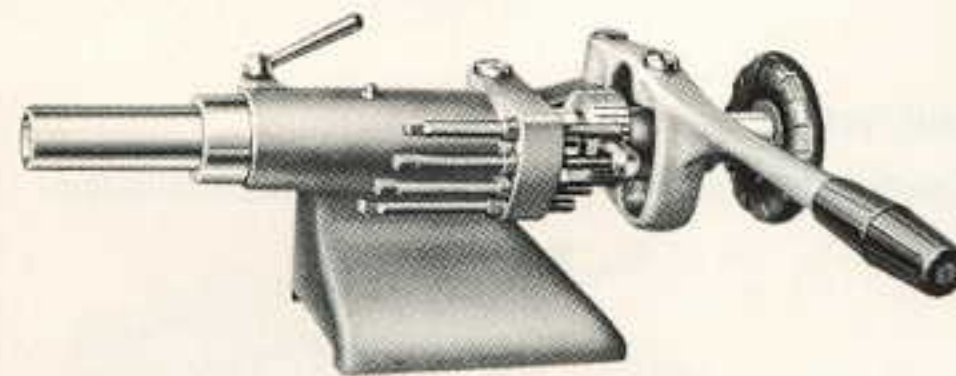

320
Lever operated tailstock with 4 adjustable stops, with collet drawbar for W 20 collets, travel of spindle sleeve 3⁹/₁₆"



322
Inclined tailstock turret head with W 20 shank for 4 tools with shanks 12 mm dia.

323
Inclined tailstock turret head with W 20 shank for 4 tools with shanks 20 mm dia.

335
Adaptor for No. 322

336
Adaptor for No. 323

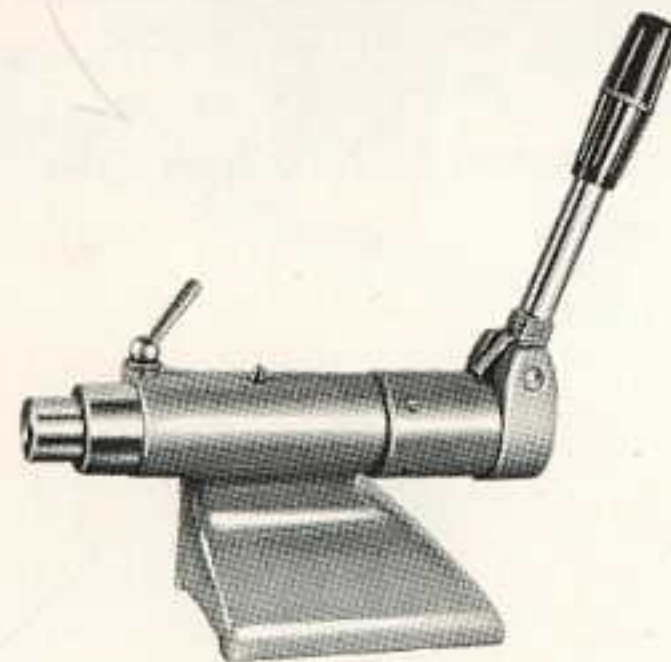

321
Lever- and spring-operated tailstock, with Morse taper 2, travel 1¹/₄"

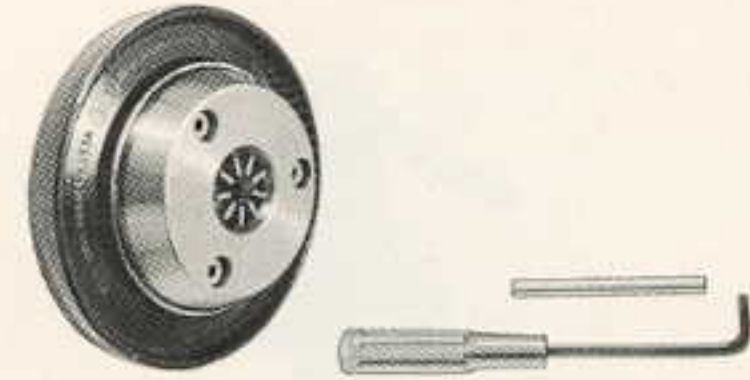

182
Collet chuck for rubber-flex collets No. 183, fitted on backplate

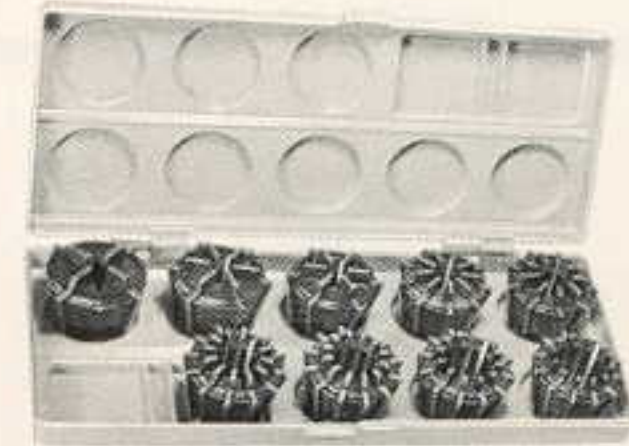

183
Rubber-flex collets with steel collet jaws. Set comprising 10 collets for an infinitely variable capacity from 3/32" to 1¹/₈" , .1" range per collet



220
Hand rest



221
Rectangular table for hand rest 2³/₄" x 4"



229
Fixed steady with 3 jaws, maximum opening 2"

Precision screw cutting lathe

DZ-450



415
Universally adjustable grinding drive, interchangeable, fits on all drives, with automatic tightening of the cord, roller carried in ball bearings, necessitates the cord pulley No. 465 or 466



440
Hand switch in mounting casing, for running in both directions, for single-speed motors

441
Hand switch in mounting casing, for running in both directions, for two-speed motors



442
Hand switch with motor protection switch, in mounting casing, for running in both directions, for single-speed motors

445
Hand switch with motor protection switch, in mounting casing, for running in both directions, for two-speed motors



465
Cord pulley, normal dia. 7" / 3 3/4" / 2 1/4", for grinding attachment 5000-18 800 r.p.m. (motor 3000 r.p.m.)

466
Cord pulley dia. 10" / 7" / 3 3/4", for grinding attachment 5000-26 000 r.p.m. (motor 3000 r.p.m.)

TV-45
Electric individual drive with geared reduction drive for speeds 1:1 and 1:6, toothed wheels hardened and ground running in oil bath

Individual drive TV-45		Headstock speeds	
Motor: Speeds r.p.m.* Output HP	Item No.	Headstock with reduction gear W 20 Item 214	
		Number of steps	r.p.m.
1500 0.8	410	12	14-1380
	417	12	22-2080
3000 1.1	412	12	28-2750
1500/3000 0.75/1.1	411	24	14-2750

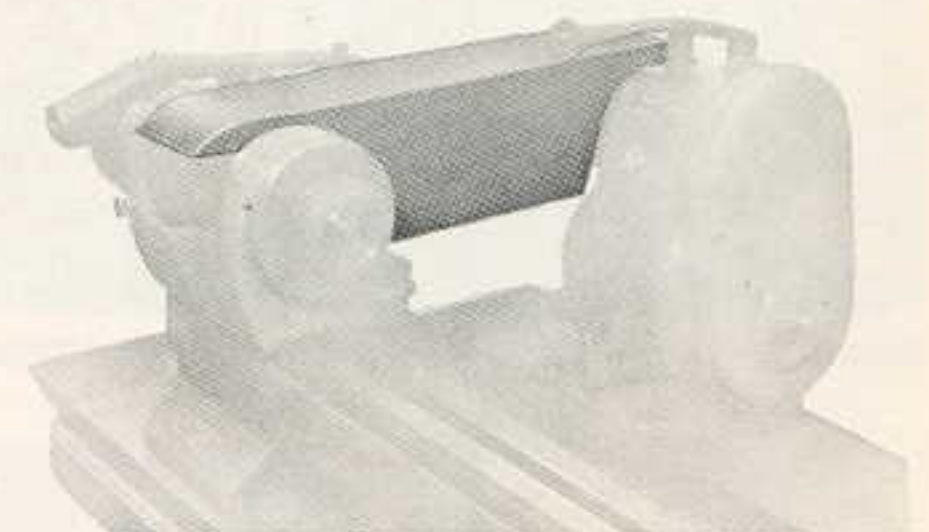

421
Guard for flat belt between individual drive and headstock

SIMONET + CO. LTD
MACHINE TOOL WORKS
4500 SOLEURE/SWITZERLAND
PHONE 065/277 21
TELEX 34 623

SIMONET



**Precision
screw cutting lathe**

DZ-450



610
Box-form bench of sheet steel, with 3 swivelling tool drawers, 1 tool shelf, central lock for drawers and shelf, bench top 25½" x 47", height 34"

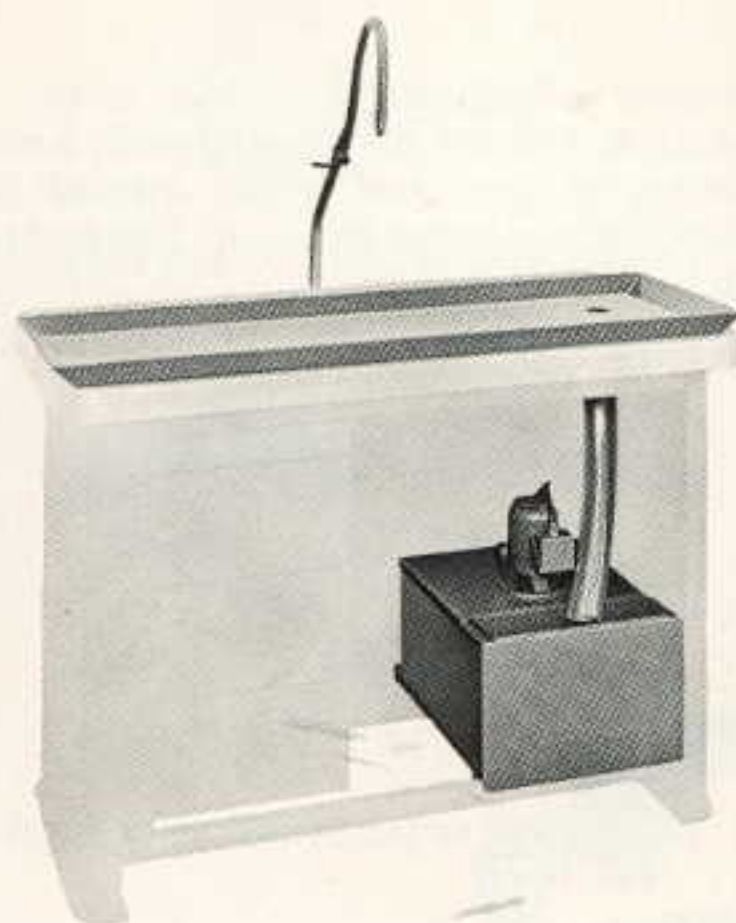

615
Swarf tray with drain pipe

620
Coolant equipment with tank (capacity 6½ gal.) electrically-driven pump with built-on switch (delivery 8 gal./min.), including fittings

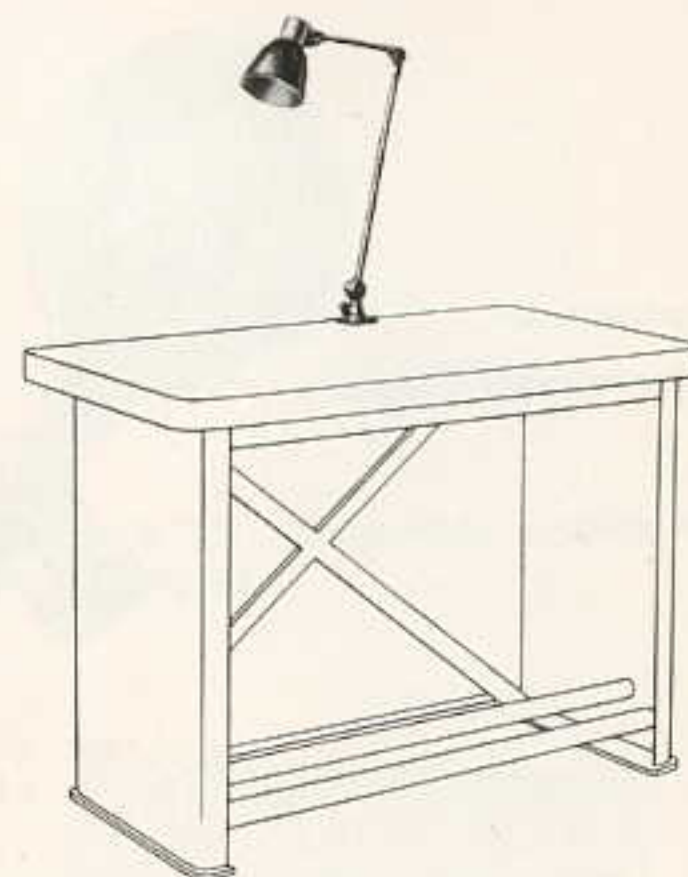

625
Lighting fitting with switch and 3-pole plug

Planer

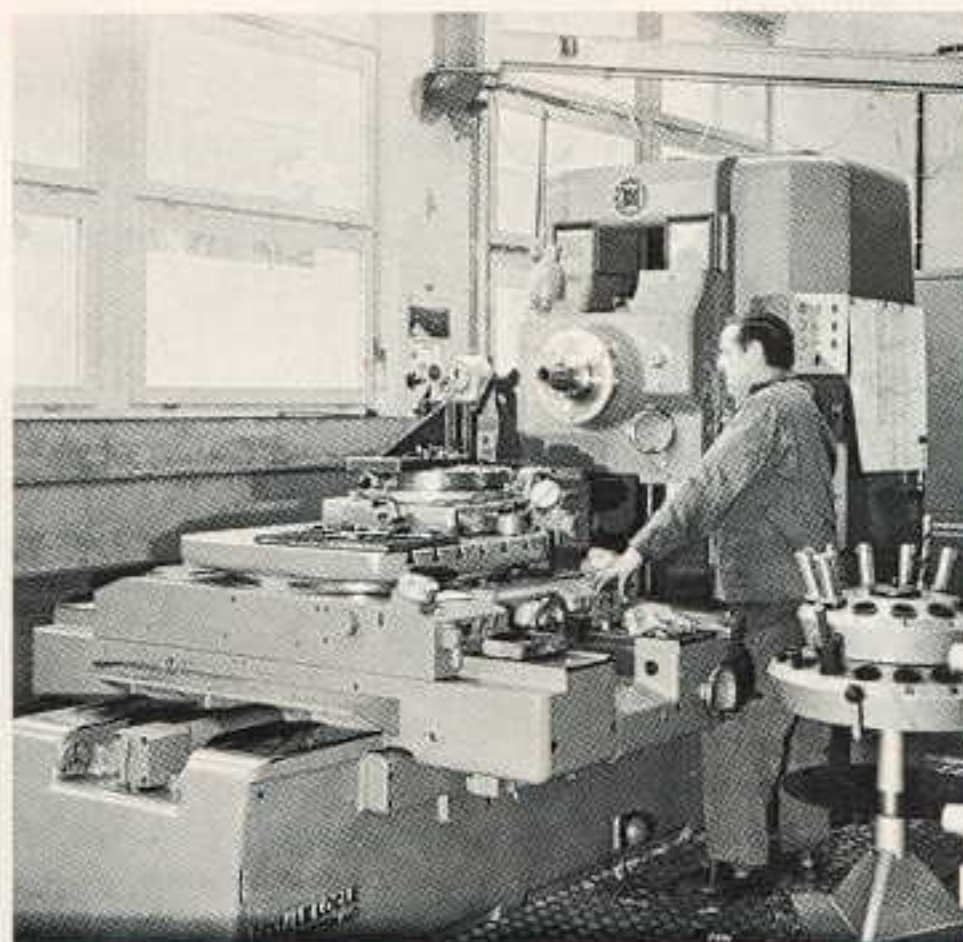
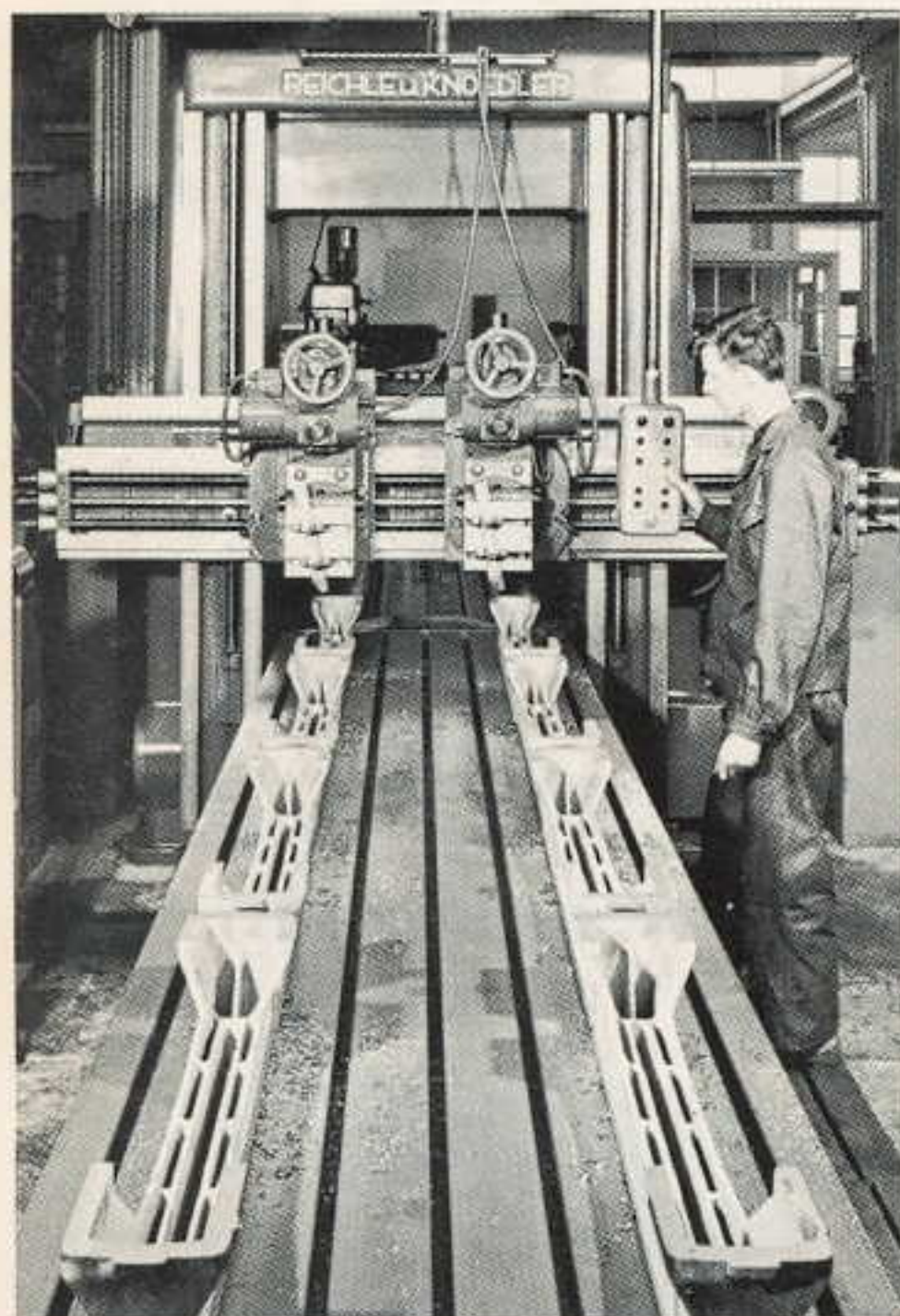

Horizontal jig boring mill

Assembly shop



SIMONET + CO. LTD
MACHINE TOOL WORKS
4500 SOLEURE/SWITZERLAND
PHONE 065/277 21
TELEX 34 623

SIMONET



Illustrations and specifications are not binding / Printed in Switzerland

Screw cutting lathe DZ-450

BRUNNER MACHINE TOOLS LTD.,
241-7 HIGH STREET,
ACTON, LONDON, W.3.
Tel. 01-992 6011.

Working Instructions DZ-450 Screw cutting lathe

TRANSPORT

For the transport, the machine remains completely assembled together. The cross slide is clamped to the bed by means of the clamping eccentric 12, which is located behind on the cross-slide guide. When receiving the machine, clean all grease-covered parts with a cloth soaked in kerosene.

ACCURACY OF THE MACHINE

Before leaving our works, the lathe is tested with regard to accuracy in accordance with the accompanying test report. It has no error greater than the values permitted according to Prof. G. Schlesinger's "Testbook for Machine Tools".

This accuracy, however, is to a large extent dependent on the accuracy with which the precisely scraped lathe-bed is set up and levelled. (See sheet 2).

LUBRICATION

All lubricating spots indicated on the accompanying sheet No. 16 have to be lubricated periodically with the prescribed lubricants.



SIMONET & CO. A.G.
SOLOTHURN SCHWEIZ

Geschr.	25.5.56	<i>Reger</i>	Nr.	PD-50-84	Sheet No.
Gepr.					1

Urh. ht an Zeic und
Beilagen, die dem Empfänger anvertraut sind, Ver-
bleibt jederzeit unserer Firma. Ohne unsere schrift-
liche Genehmigung dürfen sie weder kopiert noch
vervielfältigt, auch niemals dritten Personen mit-
geteilt oder zugänglich gemacht werden.

Leitspindelrehbank DZ-450

Transport mit Kran.

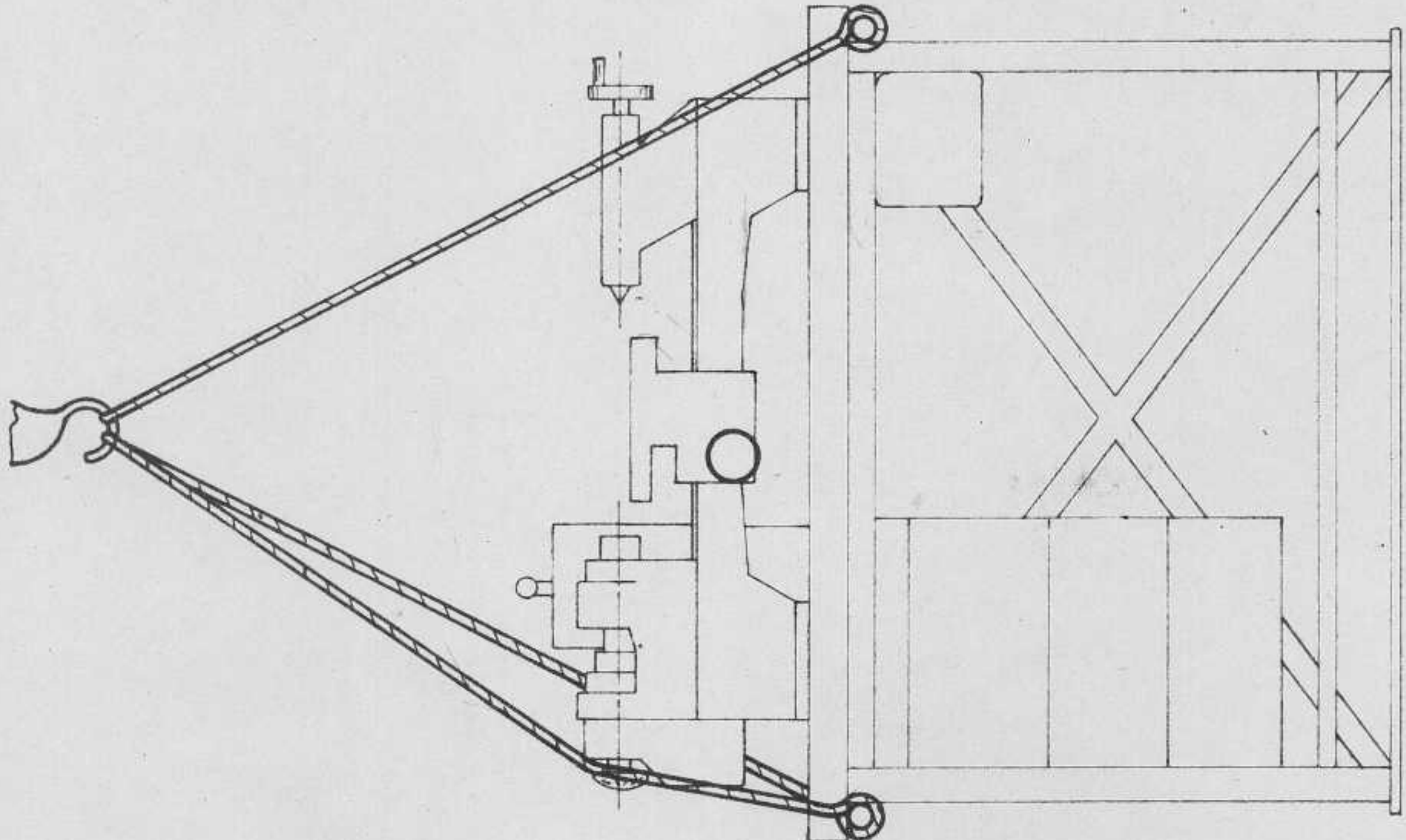
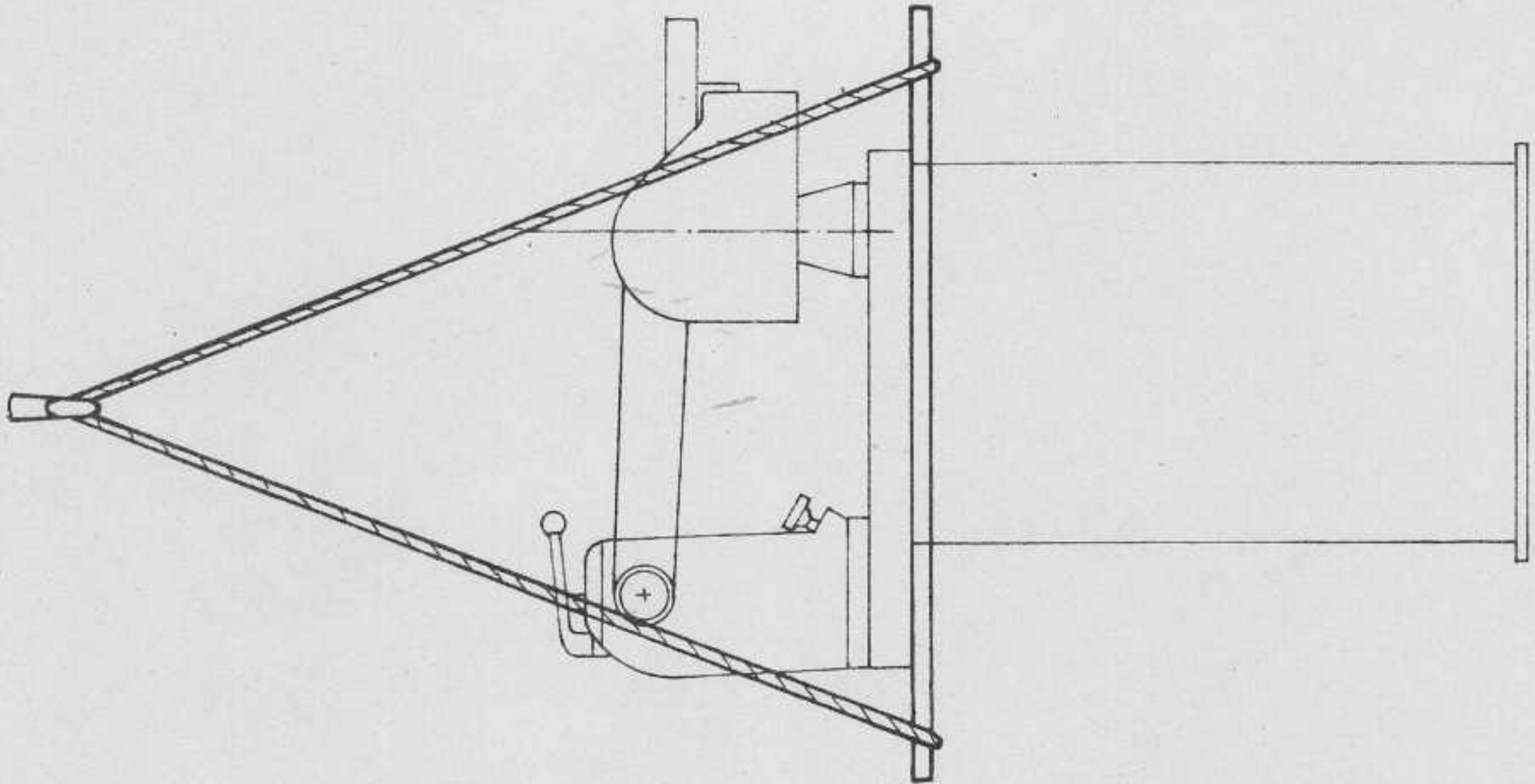

SIMONET & CO. A.G.
SOLOTHURN SCHWEIZ

Geschr. 1.9.69 *He*
Gepr.

Nr. PD-50-606/2

Blatt Nr. 1/1

Urtheil an Zeit und Beilagen, die dem Empfänger anvertraut sind, verbleibt jederzeit unserer Firma. Ohne unsere schriftliche Genehmigung dürfen sie weder kopiert noch vervielfältigt, auch niemals dritten Personen mitgeteilt oder zugänglich gemacht werden.

Bench lathes DC-102 DD-102 DR-102 DZ-450

SETTING UP THE MACHINE

The lathe must be set up or erected in such a way that no twisting stresses can be caused in the lower part or in the bed.

Check and level the bed accurately longitudinally and transversely by means of a precision spirit level.

If any errors are found when checking, proceed as follows:

a) Lathe mounted on box stand, item No. 610

Loosen the four locknuts of the through-going fixing screws B.

Re-adjust and level with these four fixing screws B.

Tighten moderately the locknuts of the four fixing screws B.

The alignment of the centres must be checked with a checking arbor and a dial gauge. Preferably, first overhung in the headstock, and then between the centres.

b) Lathe fixed on a workbench (wooden bench)

Fix the two cast-iron fixing plates onto the bench from below with the four wood screws D. After inserting two bushes E which must agree with the thickness of the bench, place the bed in position, and fix it moderately with the two fixing screws A. The highest point on left-hand and right-hand bush E is designated by a punch mark and must point outwards. Then accurately set and level the bed longitudinally and transversely with the four fixing screws B.

All four screws B must then take part in the fixing.

Tighten moderately the locknuts of the four fixing screws B.

The alignment of the centres must be checked with a checking arbor and a dial gauge. Preferably, first overhung in the headstock, and then between the centres.

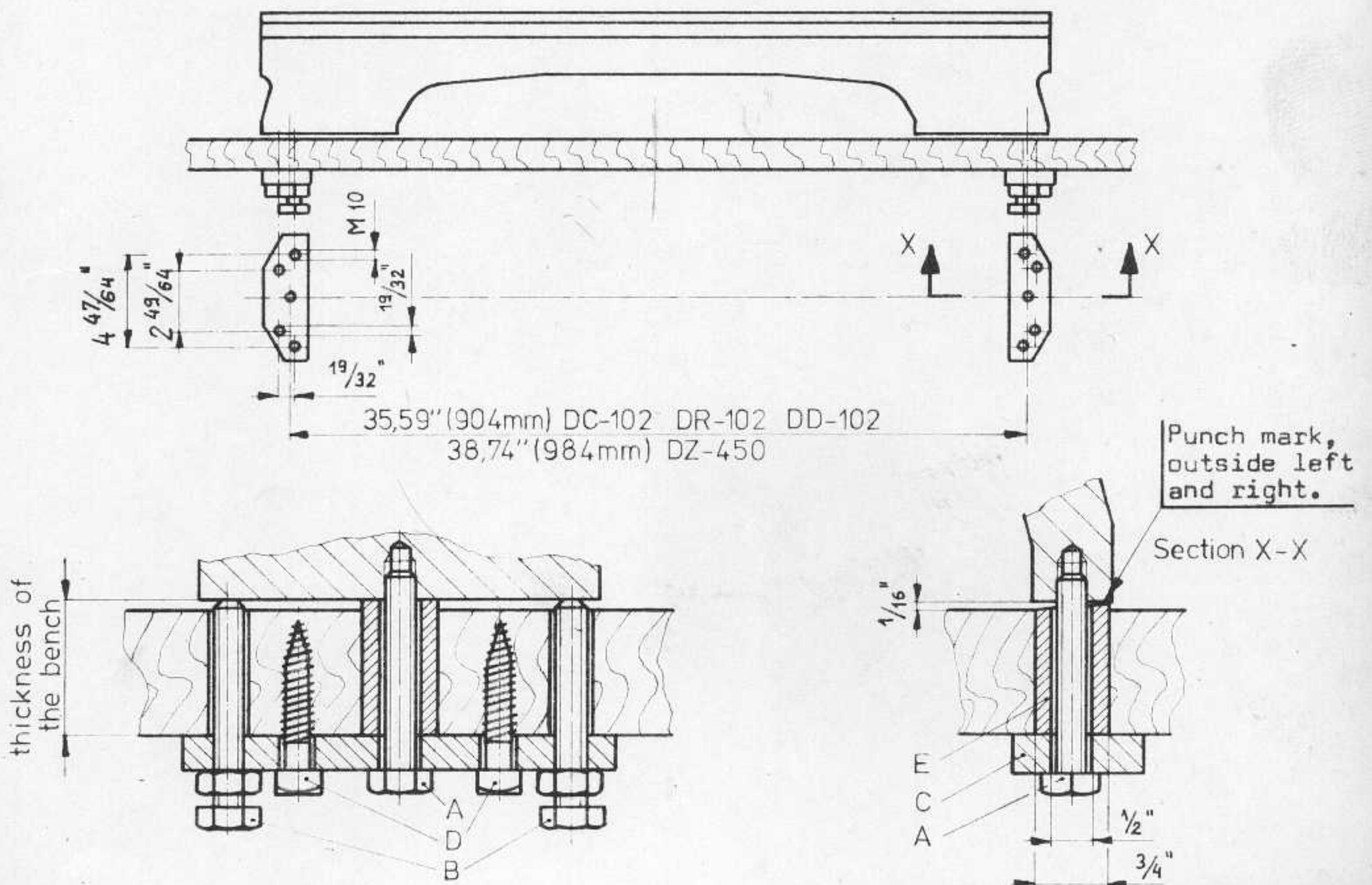

SIMONET & CO. A. G.
SOLOTHURN SCHWEIZ

Geschr. 28.9.71 H. Z. 1119

Nr.

PD-50-85

Blatt

Nr.

2

Gepr.

Bench lathes DC-102 DR-102 DD-102 DZ-450

HEADSTOCK WITH REDUCTION GEAR, Item no. 214

The spindle can be locked in 12 positions by the rotary knob on the rear portion of the bearing. For very accurate dividing work, the eccentrically supported index pin is adopted. It has to be set onto the suitable circle of holes (48, 60, 100) and clamped with the set screw. For such dividing work, it is necessary to tighten the threaded pin 5 on the stepped pulley; in this way the pulley is connected direct with the spindle. In this case, the headstock reduction gear must of course remain disengaged.

By a light pull on the flat belt, the shifting operation of the gear can be facilitated. This shifting may only be done with the lathe at rest.

The two headstock bearings must be sufficiently lubricated periodically with a good mineral oil free from acids (viscosity about 3 - 4° E at 50° C). The oil level in the reduction gear should not be higher than the middle of the inspection window.

The two ball bearings I with sealing discs are supplied filled with grease and do not require any attendance.

As gear oil we recommend the following makes: (In alphabetical order)

Caltex Oil	Regal AZ	2,9° E at 50° C
Esso Standard	Teresso 43	2,8° E at 50° C
Shell	Vitrea 27	3° E at 50° C
Vacuum Oil (Mobil Oil)	DTE light	2,8° E at 50° C

The re-adjusting of the bearings requires a certain amount of care and should only be carried out by men skilled in such work. The desired radial and axial play of the front bearing can be adjusted accurately by the threaded ring A, which is located behind the front taper bearing and is secured by two set screws, the bearing being touched up on the front face, if necessary. When doing so, take care that the contact surfaces remain strictly plane. The rear cylindrical bearing can be re-adjusted by tightening the threaded ring C on the side of the stepped pulley, and then at the same time the threaded ring E at the left must be loosened and possibly the insert in the bearing F may have to be re-machined.



SIMONET & CO. A.G.
SOLOTHURN SCHWEIZ

Geschr. 10.8.67

Alle.

Nr.

PD-50-90 A

Blatt
Nr.

3

Gepr.

Maximum speed 2500 rpm.

Motor speeds in rpm.											
Initial speeds of the individual drive in rpm.											
Headstock speeds in rpm. Reduction gear disengaged											
Headstock speeds in rpm. Reduction gear engaged											

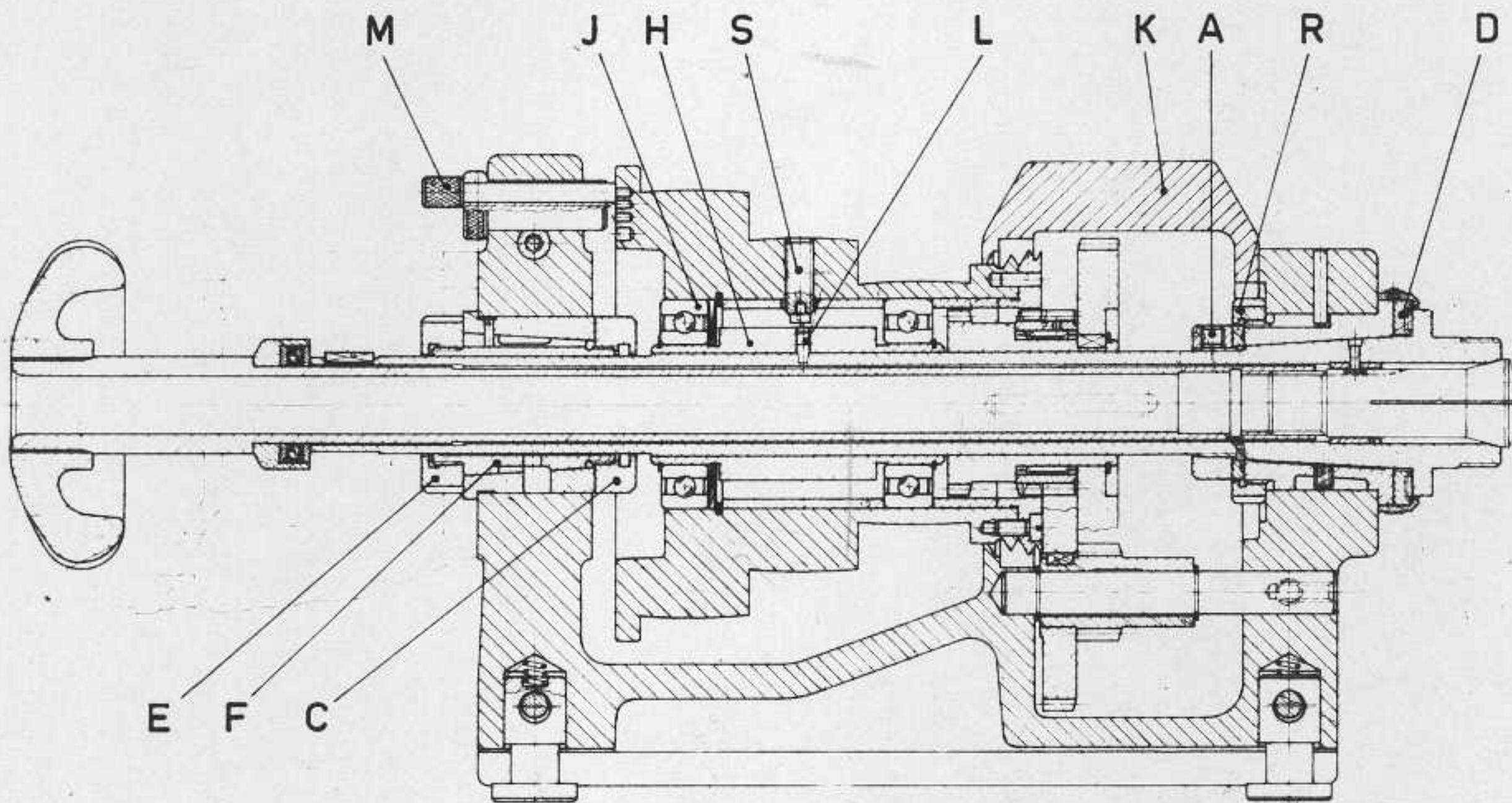

Dismantling

Remove cover K and unscrew threaded ring R. Screw out set screw S and loosen grub screw L until sleeve H is free to move on the spindle. Then the spindle together with the front bearing can be withdrawn to right.



SIMONET & CO. A.G.
SOLOTHURN SCHWEIZ

Geschr. 9.8.67

M.

Nr.

PD-50-91A

Blatt Nr.

4

Urh...ht ar...r Zei... und...
 Beilagen, die dem Empfänger anvertraut sind, ver-
 bleibt jederzeit unserer Firma. Ohne unsere schrift-
 liche Genehmigung dürfen sie weder kopiert noch
 vervielfältigt, auch niemals dritten Personen mit-
 geteilt oder zugänglich gemacht werden.

Bench lathes DC-102, DR-102, DD-102, DZ-450.

CROSS SLIDE No. 216, 217 and 510

VERTICAL SLIDE No. 250

INTERCHANGEABLE LEVER-OPERATED SLIDE No. 272

SLOTTING ATTACHMENT No. 270

All slides can be taken to pieces quickly and easily. They should be thoroughly cleaned once a week and at the same time lubricated with a mineral oil free from acids and having a viscosity of 3 - 4° E at 50° C. (Clean well behind the wedge guide, but do not lubricate).

By screwing out the conveying spindles or by loosening the flange of the lever-operated slide, the slide guideways are rendered easily accessible. The ball bearings of the feed screws are provided with a permanent grease packing and do not require any attention in service.

The play of the slide guides can be adjusted along the wedge guide by means of the threaded pins. In order not to stress the conveying spindles laterally, the bearing flange should be loosened and then screwed tight again in the foremost position. Any backlash appearing in the feed screw bearing can be taken up by means of adjusting collar A and the associated set screw.

After having taken up backlash, check and make sure that the bearing runs free.

The screw-nut A can be rendered accessible as follows: Take out the taper pin S and remove the crank, intermediate bush and dividing drum. If the conveying spindles and nuts have become much worn, these parts must be replaced by new ones. The same elements can be used for the longitudinal slide and the cross slide.

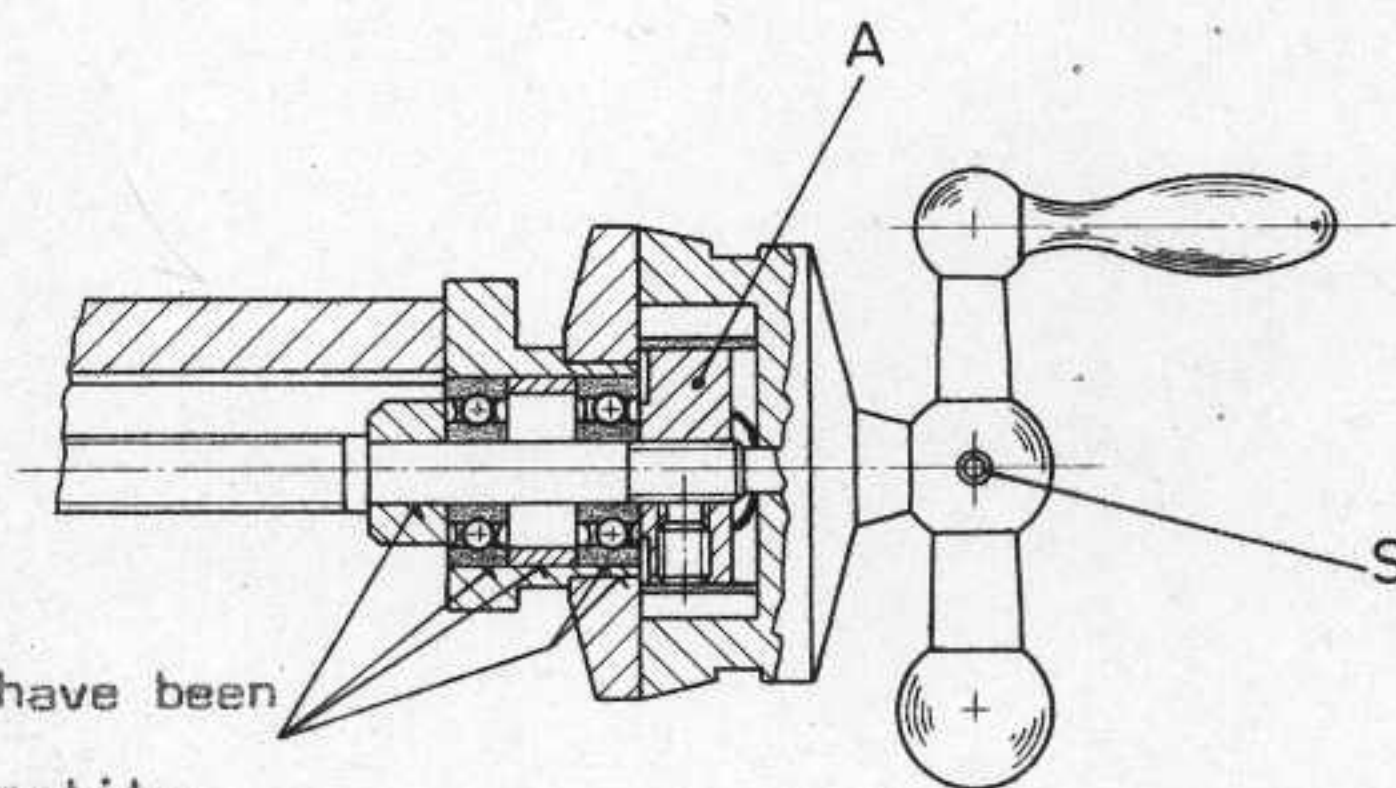

These parts have been secured by Loctite.

(Retaining compound)



SIMONET & CO. A.G.
SOLOTHURN SCHWEIZ

Geschr. 17.11.67 U.W.
Gep.

Nr.
PD-50-97A

Blatt
Nr.
5

Bench lathes DC-102 DR-102 DD-102 DZ-450

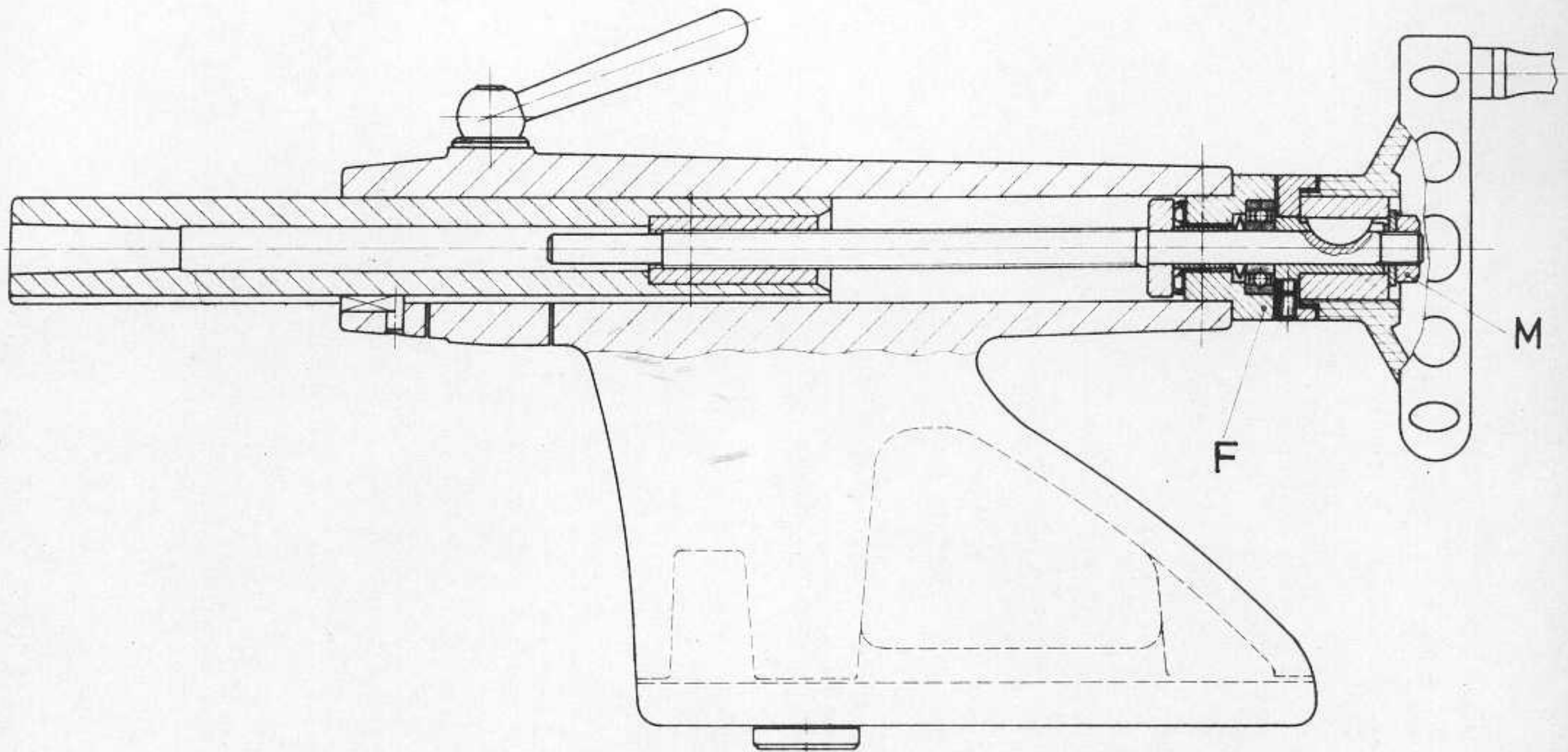

TAILSTOCK Item No. 218

The tailstock spindle sleeve can be screwed out completely for cleaning and for lubricating the bore as well as the traversing nut. Lubricate with non-acid mineral oil, viscosity at $50^{\circ}\text{C} = 3 \text{ to } 4^{\circ}\text{E}$.

The ball bearing of the traversing screw is provided with the so-called permanent lubrication and does not require any attention in service; the thrust needle bearing is delivered likewise with a "permanent" crease packing.

If the bearing has too much play, it can be taken up by tightening nut M. When doing this, the bearing should go on running free, i.e. when the tailstock spindle sleeve has been screwed out, the handle of the handwheel should bear downwards by reason of its own weight.

When, due to wear, too much backlash occurs, the traversing screw and nut must be replaced. The flange F is secured by 2 taper pins.



SIMONET & CO. A. G.
SOLOTHURN SCHWEIZ

Geschr. 16.2.72

102219

Nr.

PD-50-99A

Blatt
Nr.

6

Individual drive TV-45

INDIVIDUAL DRIVE TV-45, No. 408-419,

Works no.: _____

The headstock is driven horizontally from the individual drive TV-45. Built within this are the motor and also the toothed-wheel reduction gear (1:6). The latter is actuated by means of the lever on the casing. With the lever in the middle position, the gear remains disengaged. (Idling position). The shifting operation may be facilitated, if necessary, by a light pull on the headstock driving belt. The gear may only be shifted when at rest. The tightness of the headstock driving belt can be finely regulated as desired by means of the tightening screw. The rapid tightening lever in the baseplate serves for changing the belt quickly from one step to another, as well as for relieving the belt pull. The tightness of the belt between motor and gearing can be re-adjusted at the upper pulley (gearing). By loosening the threaded pins and simultaneously adjusting the countersunk screws (as uniformly as possible along the whole periphery) the V-belt can be tightened or loosened.

As gear oil, we recommend the following makes:

(In alphabetical order)

Caltex Oil	Regal AZ	2.9 ⁰ E at 50 ⁰ C
Esso Standard	Teresso 43	2.8 ⁰ E at 50 ⁰ C
Shell	Vitrea 27.	3 ⁰ E at 50 ⁰ C
Vacuum Oil (Mobil Oil)	DTE light	2.8 ⁰ E at 50 ⁰ C

When working 8 hours daily, the ball bearings of the motor should be thoroughly cleaned once every 2 years and provided with fresh grease.

Initial speeds of the individual drive: _____ / _____
 _____ / _____

V-belt: Motor/Gearing: profile 13 x 8 mm, inner length _____ mm
 Flat belt: Individual drive/Headstock: profile 13 x 3 mm, inner length 1140 mm
 V-belt: Individual drive/Headstock: profile 13 x 8 mm, inner length 1120 mm
 Motor for 240 switchings per hour.

Motor no individual drive _____
 Motor no coolant pump _____



SIMONET & CO. A.G.
 SOLOTHURN SCHWEIZ

Geschr. 4.11.64 Hug
 Gepr. _____

Nr. PD-50-102

Blatt Nr. 8

Urhe...ht an...Zeit... und...
 Beilagen, die dem Empfänger anvertraut sind, ver-
 bleibt jederzeit unserer Firma. Ohne unsere schrift-
 liche Genehmigung dürfen sie weder kopiert noch
 vervielfältigt, auch niemals dritten Personen mit-
 geteilt oder zugänglich gemacht werden.

Bench lathes DC-102 DR-102 DD-102 DZ-450

Wiring diagram

Motor with two speeds for rotating in either direction.

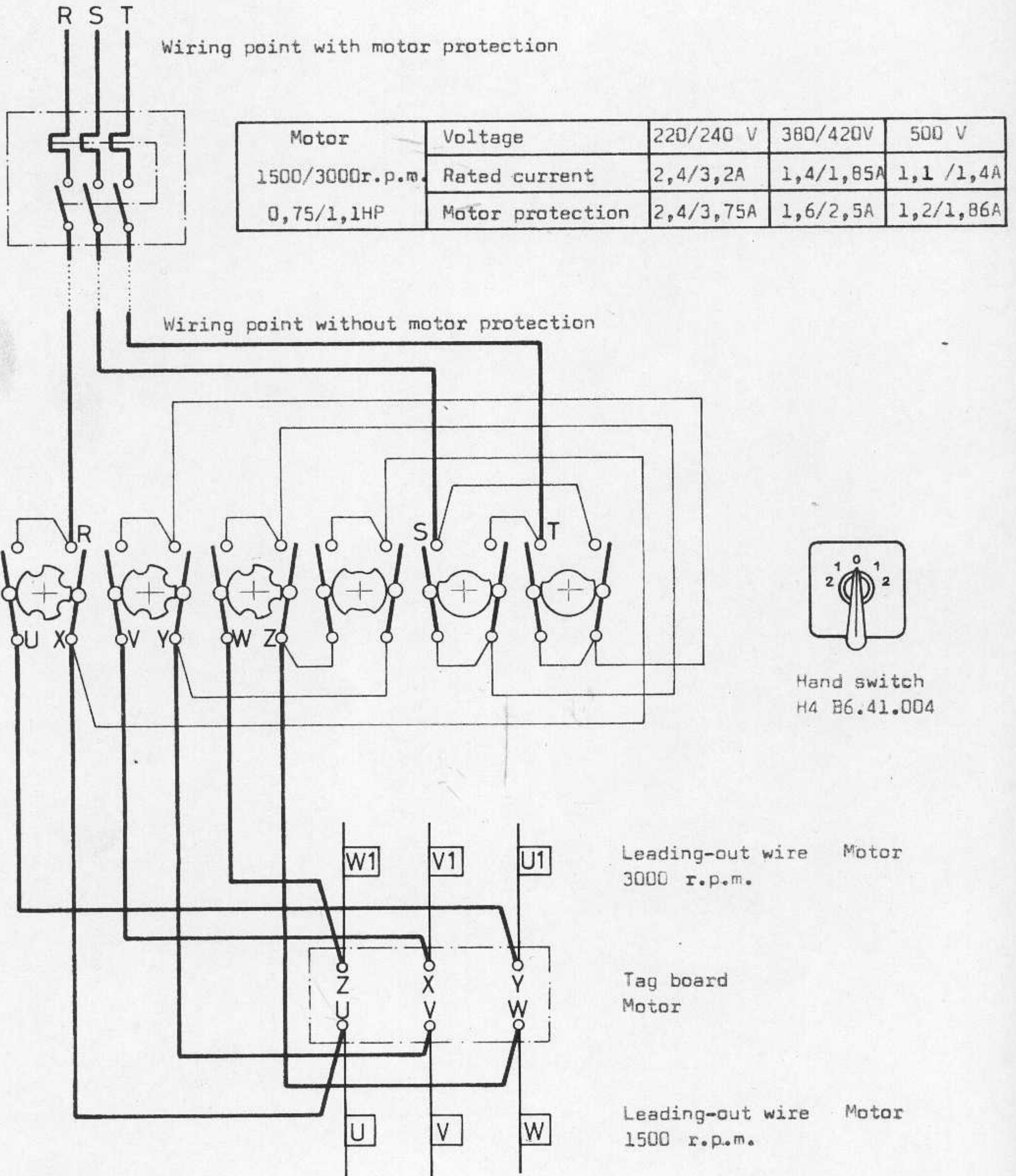

heber... in die... alle...
 Beilagen, die dem Empfänger anvertraut sind, ver-
 bleibt jederzeit unserer Firma. Ohne unsere schrift-
 liche Genehmigung dürfen sie weder kopiert noch
 vervielfältigt, auch niemals dritten Personen mit-
 geteilt oder zugänglich gemacht werden.



SIMONET & CO. A.G.
SOLOTHURN SCHWEIZ

Geschr. 12.172



Nr. PD-50-105

Blatt Nr. 10

Gepr.

Screw cutting lathe DZ-450

SCREW CUTTING AND AUTOMATIC LONGITUDINAL FEED

First of all, make sure that the clamping eccentric 12 under the cross slide is loosened; this eccentric clamps the slide to the bed during transverse turning. After removing the collet tube and the protecting cover, the change wheels are accessible. According to the change-wheels table which is provided inside the protecting cover (see also sheets 13 and 14), the desired pitch of thread or feed can be selected. The change wheels are fixed, according to the given diagram, on the change-wheel bolts and quadrant or on the lead screw respectively. The fine-feed gear (1:4) can be engaged or disengaged by the handle 4. By changing-over the lathe-dog lever 1, the lead screw is engaged or disengaged, or its direction of rotation is changed with respect to the direction of rotation of the headstock spindle. (Left-hand thread or change of direction of feed). The lead screw has a groove along its whole length and serves at the same time as feed shaft. The longitudinal feed thus imparted by the apron to the cross slide amounts to about 1/3 of the pitch of thread produced by the change wheels.

For thread cutting, the engaging lever 10 must be pushed to the back and held in a notch.

The levers of the fine-feed gear 4 and of the lathe dog 1 may only be moved when the lathe is at rest. The shifting operation may be facilitated by pulling the flat belt.

Any play that develops in the longitudinal guides of the cross slide can be eliminated by re-adjusting the two wedge-shaped rails.



SIMONET & CO. A. G.
SOLOTHURN SCHWEIZ

Geschr. 25.5.56 *D. J.*
Gepr. *K.*

Nr.
PD-50-107

Sheet
No.
11

Das Urrecht an dieser Zeichnung und an den darin enthaltenen Erfindungen ist dem Erfindungsbesitzer vorbehalten. Ohne unsere schriftliche Genehmigung dürfen sie weder kopiert noch vervielfältigt, auch niemals dritten Personen mitgeteilt oder zugänglich gemacht werden.

Screw cutting lathe DZ-450

THE APRON

This transmits the movements of the combined lead screw and feed shaft to the cross slide.

Longitudinal turning:

When the lever 10 is drawn to the front, the longitudinal feed is engaged. It can be disconnected at any time by pulling the disconnecting knob 9 out, quickly and energetically.

Automatic disconnecting device

Two stops 2, clamped with holders 3, are provided, one on each side of the apron. The disconnecting rail 5 runs onto the stops to the left or to the right and disconnects the operations of longitudinal turning or thread cutting. The stop screw 6 serves as fixed stop during longitudinal turning. In order to ensure correct automatic disconnecting, at the moment of disconnecting there must always be a clearance of at least 0.01" between stop screw and stop contact. After the disconnecting, the slide is moved to the fixed stop 6 with the handwheel 8. In this way the turned length always remains unchanged. The stop screw 6, however may not be used for adjusting the turned lengths.

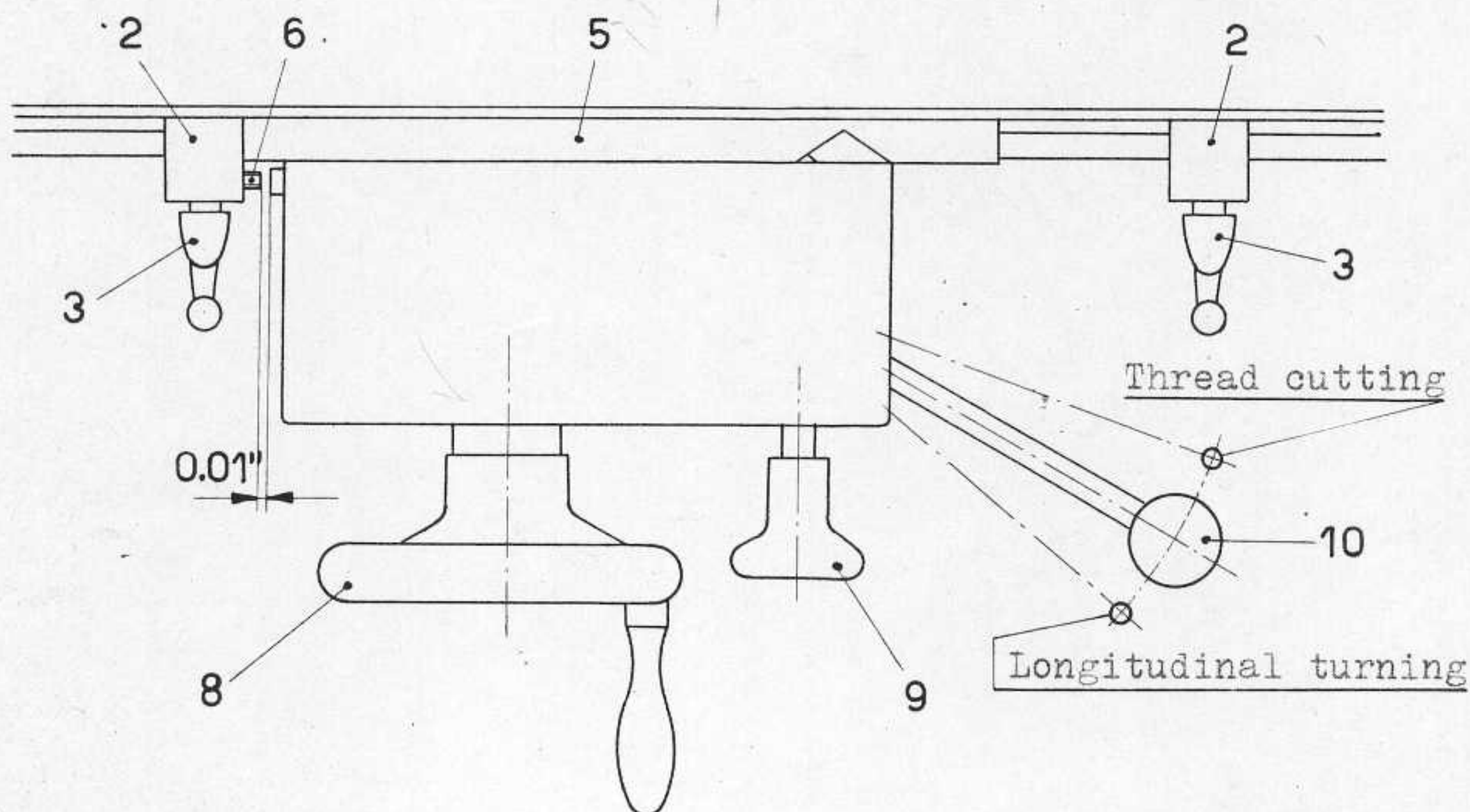

SIMONET & CO. A. G.
SOLOTHURN SCHWEIZ

Geschr. 2.3.60
Gepr.

Ull.

Nr.
PD-50-108

Blatt
Nr.
12

Urh. int. ar. Zeich. und Beilagen, die dem Empfänger anvertraut sind, verbleibt jederzeit unserer Firma. Ohne unsere schriftliche Genehmigung dürfen sie weder kopiert noch vervielfältigt, auch niemals dritten Personen mitgeteilt oder zugänglich gemacht werden.

Screw cutting lathe DZ-450

Thread cutting:

When lever 10 is pressed to the back, the split nut is closed. In order to reduce wear, this should only be done when the lead screw is at rest; the correct position is found by moving the handwheel 8.

Because of this single-lever operating, errors in gear shifting are rendered impossible.

Also this movement can be interrupted by pulling the knob 9 out. This pulling must be done quickly and energetically. When thread cutting, the return is made by reversing the sense of rotation of the motor.

OVERLOADING THE APRON

In order to prevent breakage or deformation when the apron is overloaded by mounting-up, etc., the change wheel D is coupled to the lead screw as shown in the sketch below. If the feed is brought to a standstill by an external force during longitudinal turning or thread cutting, and the motion still remains engaged, the brass pin will shear (Safety shearing device).

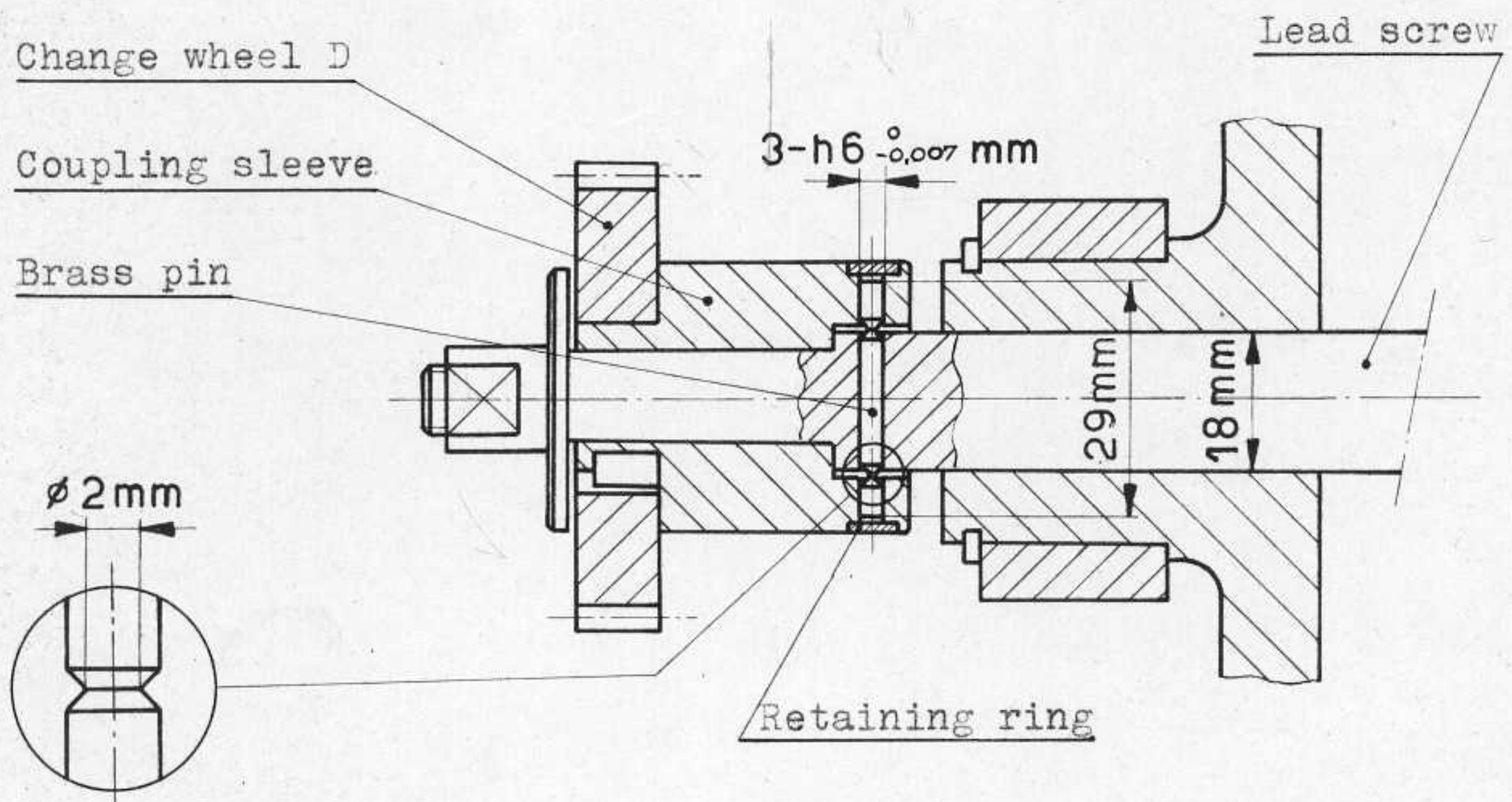

Only ORIGINAL shearing pins may be used



SIMONET & CO. A.G.
SOLOTHURN SCHWEIZ

Geschr. 2.3.60
Gepr.

Uli.

Nr.
PD-50-131

Blatt
Nr.
12A

Urh. ist an der Zeichnung und den Beilagen, die dem Empfänger anvertraut sind, verbleibt jederzeit unserer Firma. Ohne unsere schriftliche Genehmigung dürfen sie weder kopiert noch vervielfältigt, auch niemals dritten Personen mitgeteilt oder zugänglich gemacht werden.

Screw cutting lathe DZ-450

CHANGE-WHEEL TABLE

METRIC PITCHES						ENGLISH PITCHES					
Thread pitch in mm with		$\frac{A.C.}{B.C} = \frac{\text{Pitch in mm}}{3}$				Threads per inch with		$\frac{A.C.}{B.D} = \frac{25.4}{3 \times \text{threads per inch}}$			
Lever pos.		Change wheels				Lever pos.		Change wheels			
I	II	A	B	C	D	I	II	A	B	C	D
0.2	0.05	36	120	28	126	28	112	36	120	127	126
0.25	0.06	36	108	30	120	24	96	36	108	127	120
0.3	0.07	36	90	30	120	22	88	36	108	127	110
0.35	0.08	36	80	28	108	20	80	36	100	127	108
0.4*	0.1*	36	70	28	108	19	76	36	95	127	108
0.45	0.11	36	108	54	120	18	72	36	90	127	108
0.5	0.12	36	54	30	120	16	64	36	108	127	80
0.6	0.15	36	100	70	126	14	56	36	108	127	70
0.7	0.17	36	100	70	108	12	48	36	120	127	54
0.75	0.18	36	108	90	120	11	44	36	110	127	54
0.8	0.2	36	100	80	108	10	40	36	100	127	54
0.9	0.22	36	100	90	108	9	36	36	90	127	54
1	0.25	36	90	100	120	8	32	36	80	127	54
1.25	0.31	36	80	100	108	7	28	36	70	127	54
1.5*	0.37*	36	80	120	108	6	24	36	108	127	30
1.75	0.43	36	54	70	80	5	20	36	90	127	30
2	0.5	36	108	120	60						
2.5	0.62	36	54	100	80						
3	0.75	36	54	120	80						
3.5	0.87	36	60	105	54						
4	1	36	108	120	30						

Available change wheels:
 28 30 54 60 70 80 90 95 100
 105 108 110 120 126 127

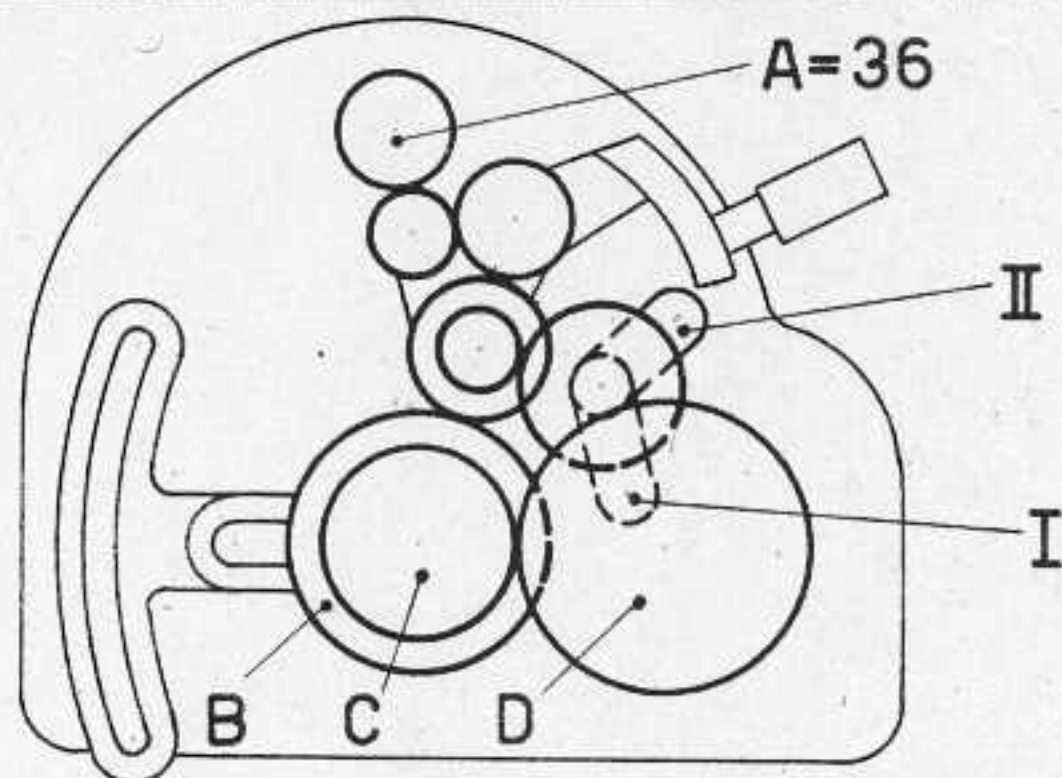

FEEDS

The longitudinal feed amounts to about 1/3 of the thread pitch. The thread pitches marked with an asterisk (*) give suitable feeds of approximately 0.13-0.03 mm and 0.5-0.12 mm per rev. respectively.



SIMONET & CO. A. G.
 SOLOTHURN SCHWEIZ

Geschr. 25.5.56 *Rap*
 Gepr. *K*

Nr. PD-50-109

Sheet No. 13

Urh. nicht an Zeic. und
 Ballagen, die dem Empfänger anvertraut sind, ver-
 bleibt jederzeit unserer Firma. Ohne unsere schrift-
 liche Genehmigung dürfen sie weder kopiert noch
 vervielfältigt, auch niemals dritten Personen mit-
 geteilt oder zugänglich gemacht werden.

Screw cutting lathe DZ-450

British Association threads

B.A.

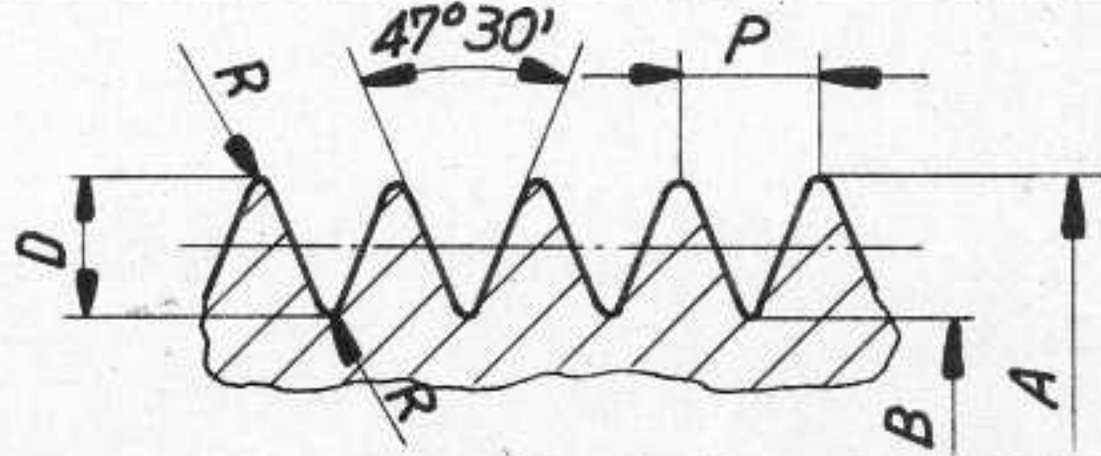

No.	Dimensions in inches							Pitch in mm	Change wheels				Pitch error mm	Additional change wheels
	Threads per inch	A	B	P	D	R	P		A	B	C	D		
		0	.2362	.1890	.0394	.0236	.0072		1.000	36	90	100		
1	.2087	.1663	.0354	.0212	.0064	0.899	36	126	110	105	-0.0011			
2	.1850	.1463	.0319	.0191	.0058	0.810	36	120	90	100	-0.0002			
3	.1614	.1272	.0287	.0172	.0052	0.729	36	108	80	110	-0.0017			
4	.1417	.1105	.0260	.0156	.0047	0.660	36	70	54	126	+0.0008			
5	.1260	.0980	.0232	.0139	.0042	0.589	36	100	70	126	+0.0107			
6	.1102	.0852	.0209	.0125	.0038	0.531	36	54	28	105	+0.0025			
7	.0984	.0758	.0189	.0113	.0034	0.480	36	100	56	126	-----	56		
8	.0866	.0664	.0169	.0101	.0031	0.429	36	108	54	126	-0.0007			
9	.0748	.0564	.0154	.0092	.0028	0.391	36	70	30	120	-0.0054			
10	.0669	.0503	.0138	.0083	.0025	0.350	36	80	28	108	-0.0006			



SIMONET & CO. A.G.
SOLOTHURN SCHWEIZ

Geschr. 25.5.56 *Dopp*
Gepr. *ki*

Nr. PD-50-110

Sheet No. 14

Die Zeichnung ist ein Werkstück und die Beilagen, die dem Empfänger anvertraut sind, verbleibt jederzeit unserer Firma. Ohne unsere schriftliche Genehmigung dürfen sie weder kopiert noch vervielfältigt, auch niemals dritten Personen mitgeteilt oder zugänglich gemacht werden.

Screw cutting lathe DZ - 450

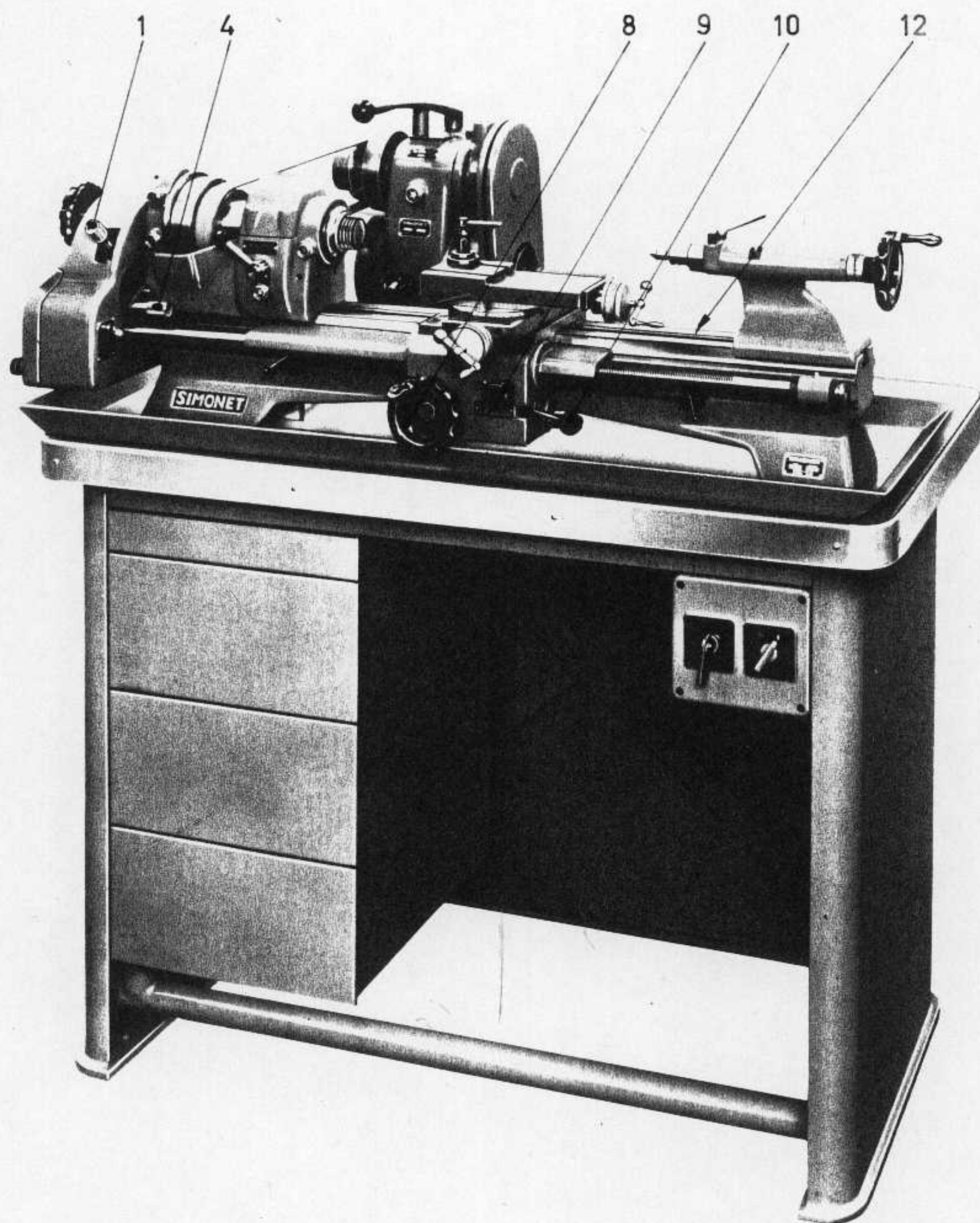

SIMONET & CO. A. G.
SOLOTHURN SCHWEIZ

Geschr 5.7.71

Handwritten signature

Nr PD-50-111

Gepr

Blatt Nr. 15

Urheberrecht an den Zeichnungen und allen Beilagen, die dem Empfänger anvertraut sind, verbleibt jederzeit unserer Firma. Ohne unsere schriftliche Genehmigung dürfen sie weder kopiert noch vervielfältigt, auch niemals dritten Personen mitgeteilt oder zugänglich gemacht werden.

Screw cutting lathe DZ-450

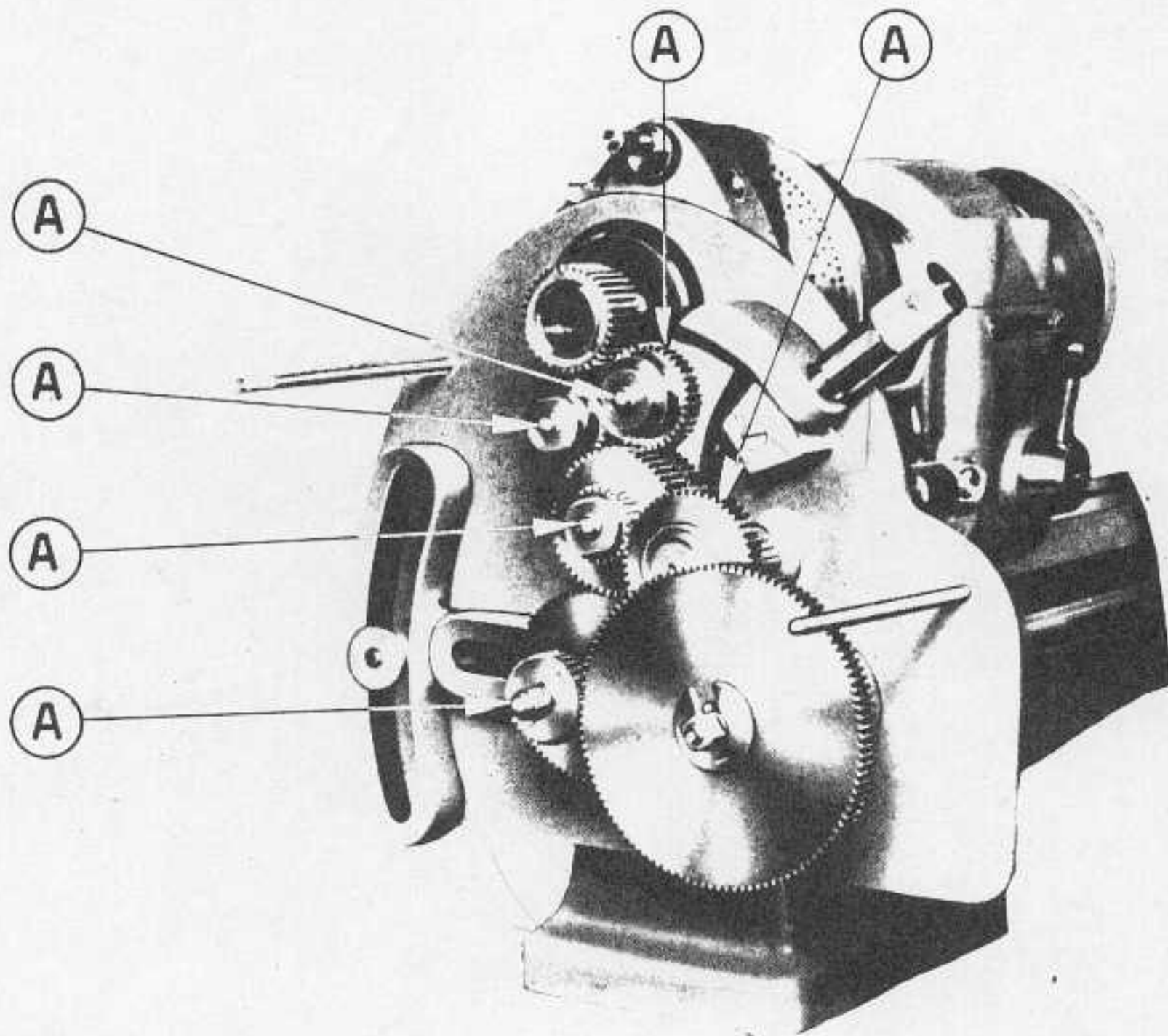
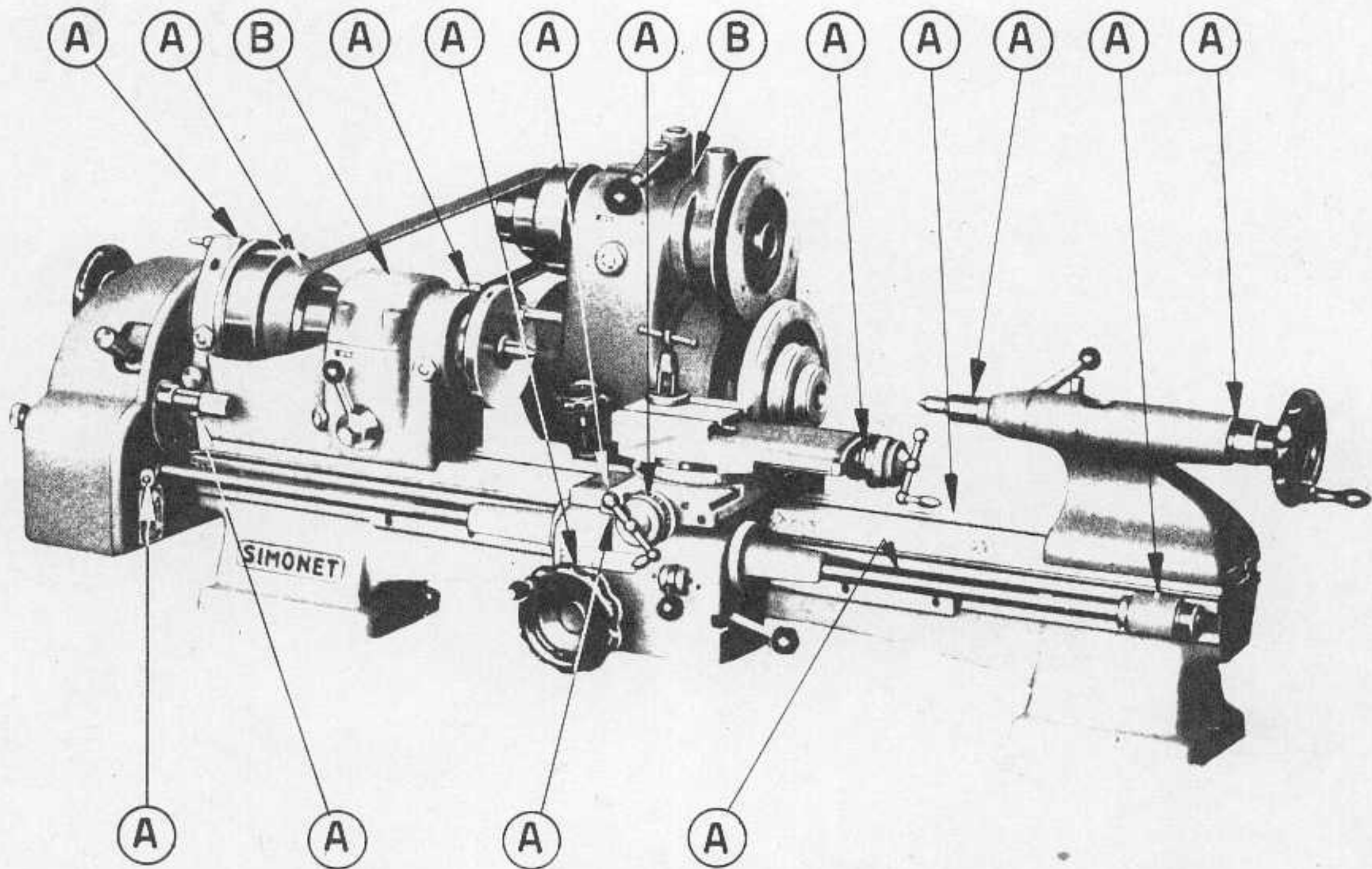

Lubricating plan

A Lubricating oil 3.5 – 4.5 °E at 50 °C

B Lubricating oil according to working instructions Sheets No. 3 and 8



SIMONET & CO. A.G.
SOLOTHURN SCHWEIZ

Gest.
Gepr.

21.65 *Hug*

PD-50-112

Sheet
No.
16

TEST SHEET FOR SCREW CUTTING LATHE DZ-450

Works number:

Height of centres: 102 Distance between centres: 450 mm

Measuring operation	Admis. error	Error found	Fig.
BED			
Bed straight in longitudinal direction (Only upwards curvature admissible)	0 mm + 0.02 mm 1000 mm		1a
Bed straight in the transverse direction	+ or - 0.02 1000 mm		1b
WORKING SPINDLE			
Centre running true	0.01 mm		2a
Spindle nose, running true	0.005 mm		2b
Inner cone for collet, running true	0.01 mm		2c
Axial play of spindle	0.01 mm		2d
Radial deflection of spindle bearing measured at the end of an arbor at 200 mm distance	0.01 mm		3a
Spindle axis parallel to the bed in the vertical plane at 200 mm	0 + 0.01 mm		4a 4b
The same in the horizontal plane (Error only admissible towards tool pressure)	0 + 0.01 mm		4c 4d
COMPOUND SLIDE REST			
Upper part of slide rest longitudinal guiding parallel to spindle in vertical plane (measured at along slide movement)	0.02 mm		5
TAILSTOCK			
Spindle sleeve parallel to the bed in vertical direction, measured on sleeve travel (only rising to the front end)	0 + 0.01 mm		6a 6b
The same in horizontal direction (Error only admissible towards tool pressure)	0 + 0.01 mm		6c 6d
Centre line parallel to the bed in vertical direction, measured with 300 mm long testing arbor between the centres	0 + 0.01 mm		7a
The same in horizontal direction. (Error only admissible towards tool pressure).	0 + 0.01 mm		7b
LEAD SCREW			
Accuracy of pitch of the lead screw on 300 mm	+ 0.03 mm		8
Longitudinal play of the lead screw	0.01 mm		8
Bearings of lead screw in alignment with each other in the vertical plane (Bearing axes parallel to bed guide). Test positions B and C.	0.1 mm		8a
The same in the horizontal plane	0.1 mm		8b
Bearings of lead screw in alignment with split nut in the vertical plane. Measured with closed split nut, and test position A as starting point.	0.15 mm		8c
ACCURACY OF THE WORKING MACHINE			
Lathe turns circular	0.005 mm		
Lathe turns cylindrical on 300 mm	0.01 mm		
Lathe turns facing (only hollow) to 200 mm diameter	0.01 mm		9

Solothurn, _____ The checker:
 _____ Countersigned by:

Remarks:
 The lathe has been tested with the belt normally tight
 For the figures see sheet No. 16



SIMONET & CO. A. G.
 SOLOTHURN SCHWEIZ

Geschr. 25.5.56
 Gepr. _____

Nr. PD-50-118

Sheet No. 17

Urh. ht an Zeid und Beilagen, die dem Empfänger anvertraut sind, verbleibt jederzeit unserer Firma. Ohne unsere schriftliche Genehmigung dürfen sie weder kopiert noch vervielfältigt, auch niemals dritten Personen mitgeteilt oder zugänglich gemacht werden.

TEST SHEET FOR SCREW CUTTING LATHE DZ-450

Figure 1

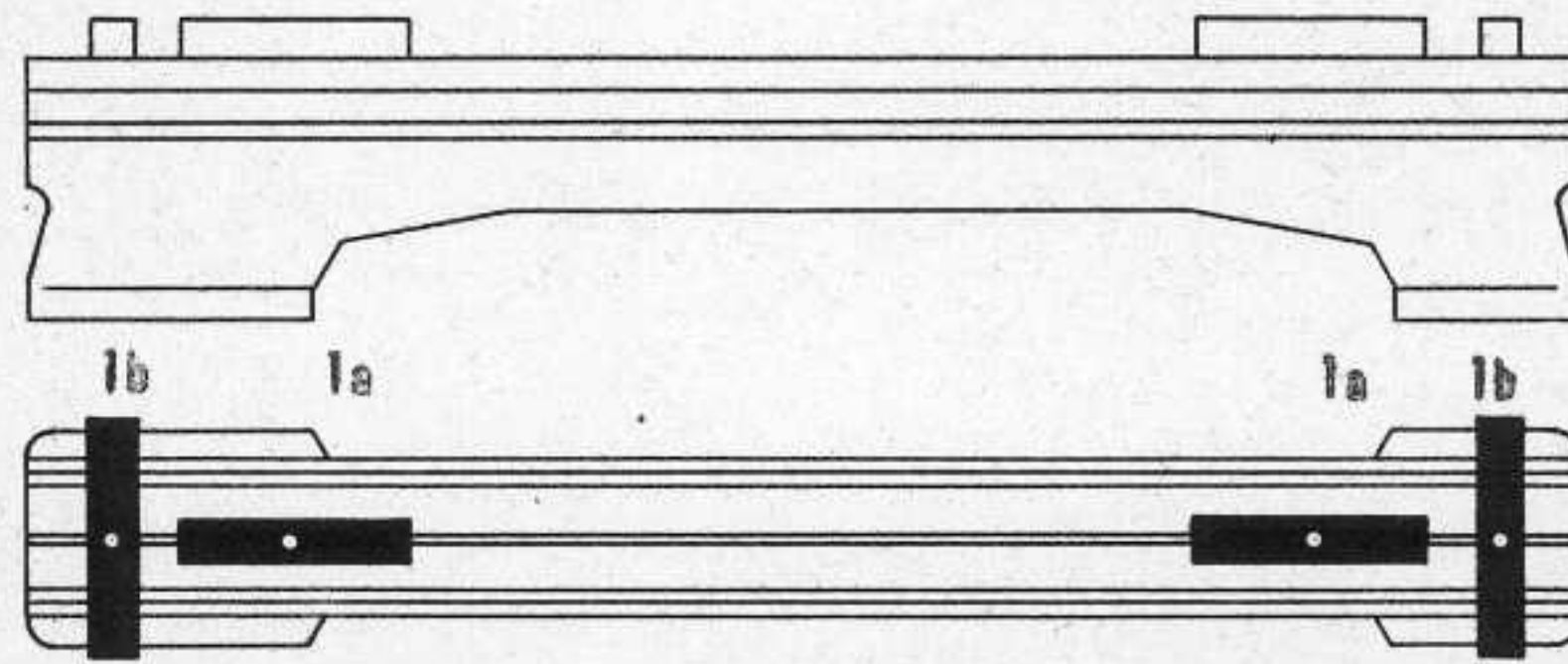

Figure 2

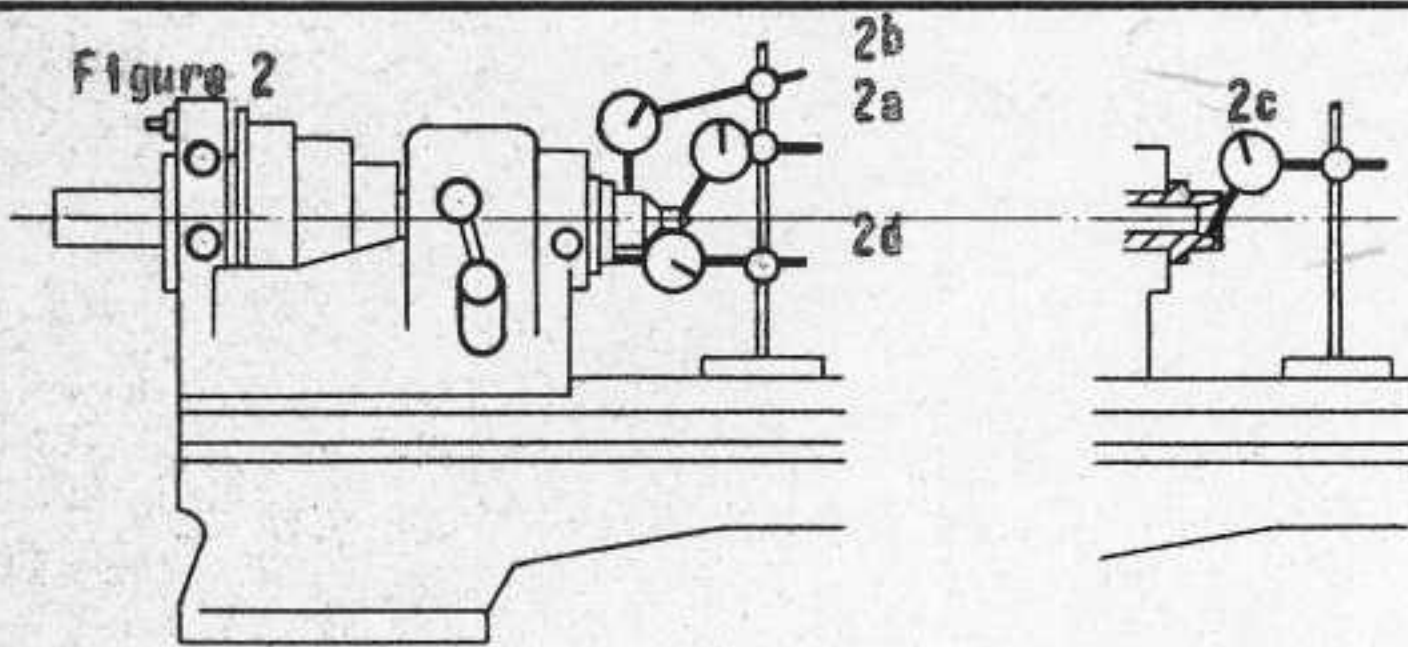

Figure 3

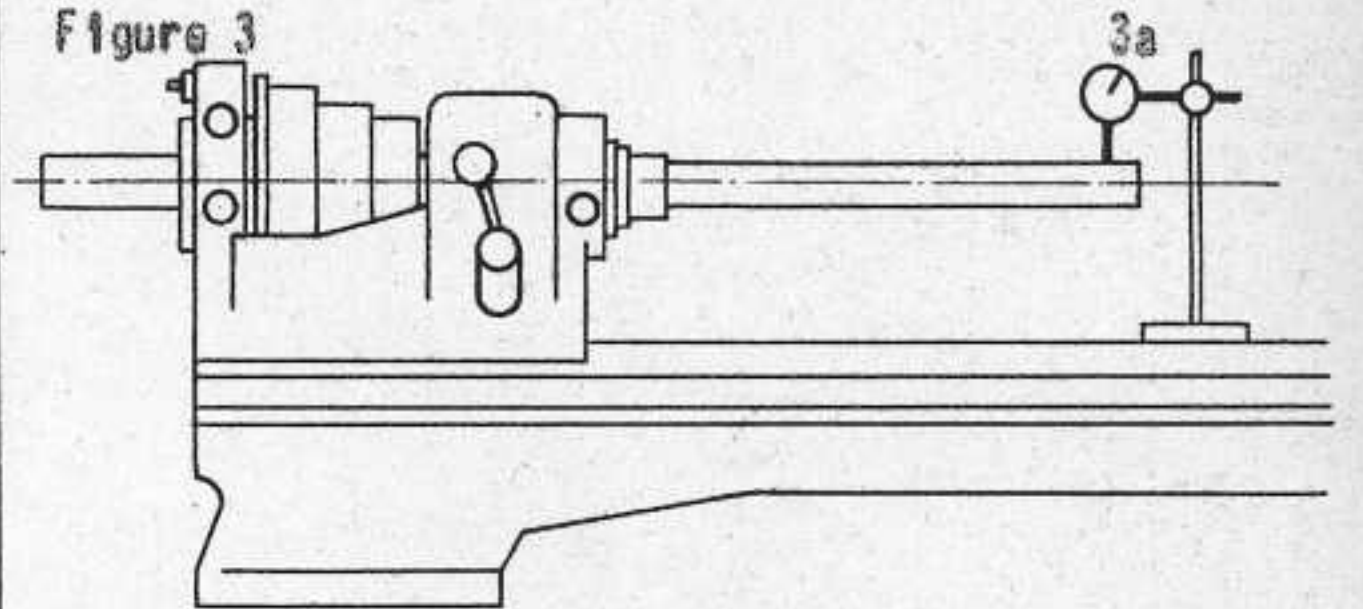

Figure 4

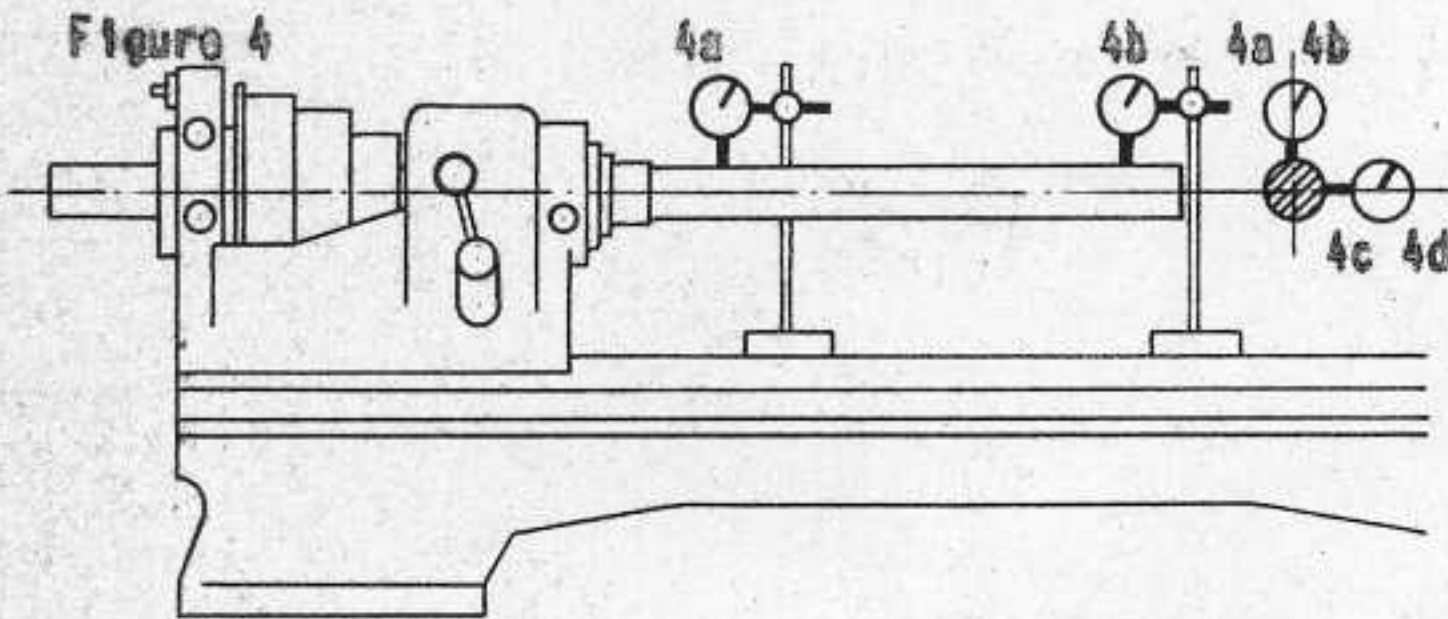

Figure 5

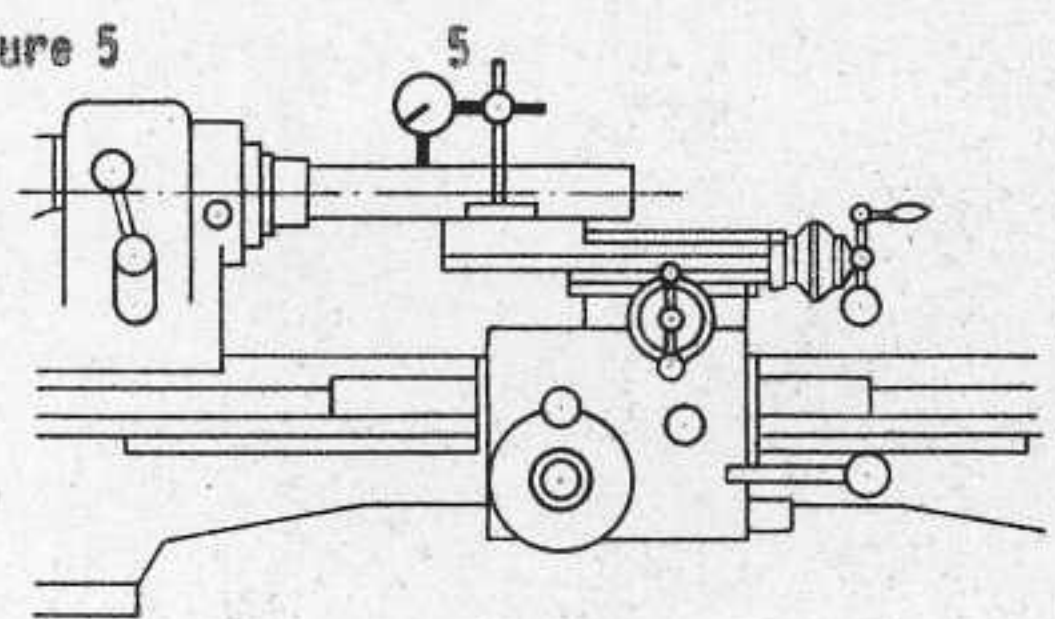

Figure 6

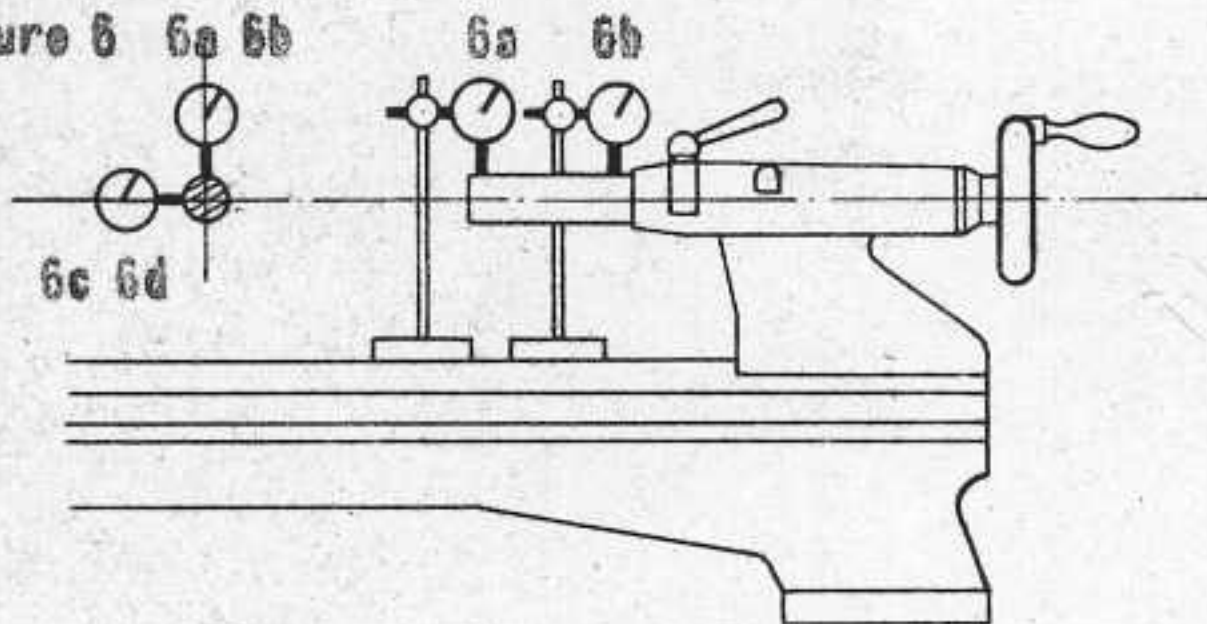

Figure 9

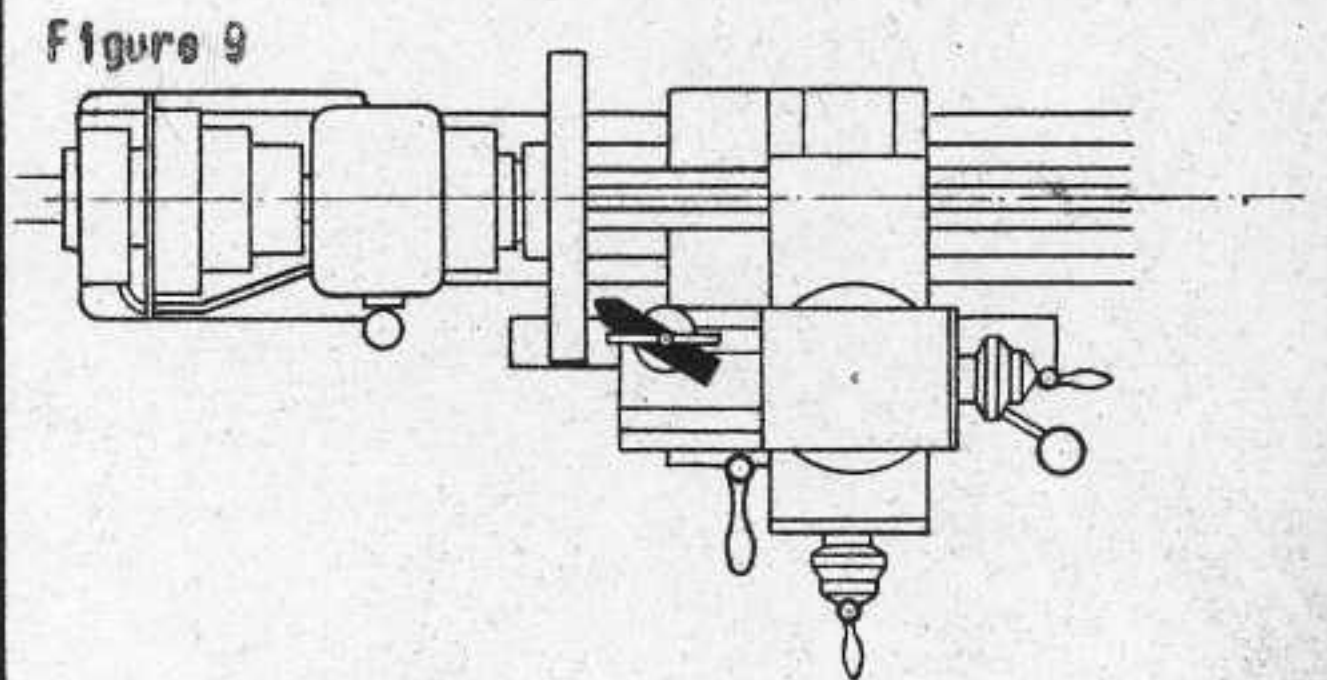
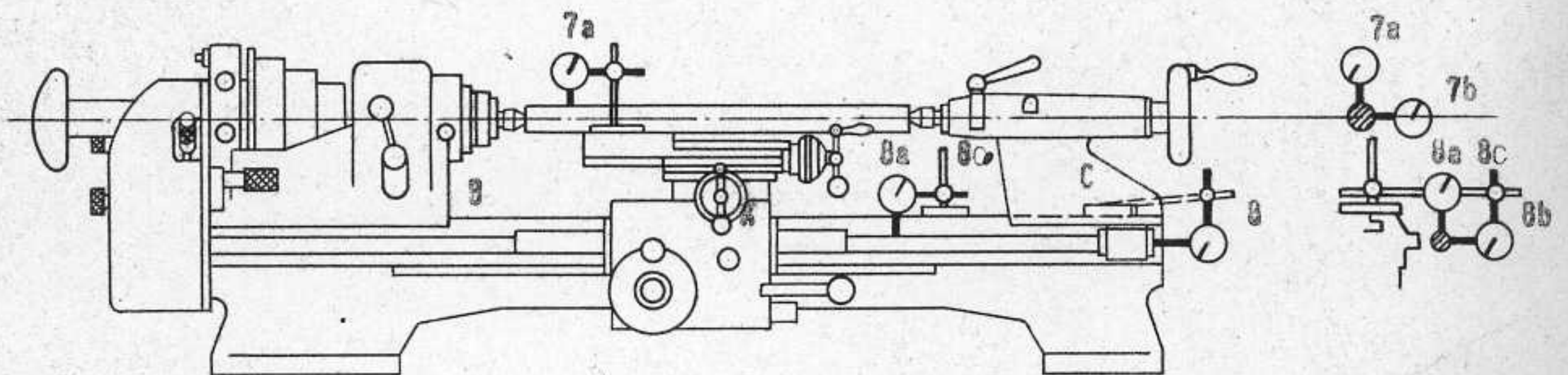

Figure 7 & 8



SIMONET & CO. A.G.
SOLOTHURN SCHWEIZ

Geschr. 25.556 *Dg*
Gepr. *Li*

Nr. PD-50-119

Sheet No. 18

Urh. d. Zeich. und
 Beilagen, die dem Empfänger anvertraut sind, ver-
 bleibt jederzeit unserer Firma. Ohne unsere schrift-
 liche Genehmigung dürfen sie weder kopiert noch
 vervielfältigt, auch niemals dritten Personen mit-
 geteilt oder zugänglich gemacht werden.