

SIEG C1 Micro Lathe Mk2

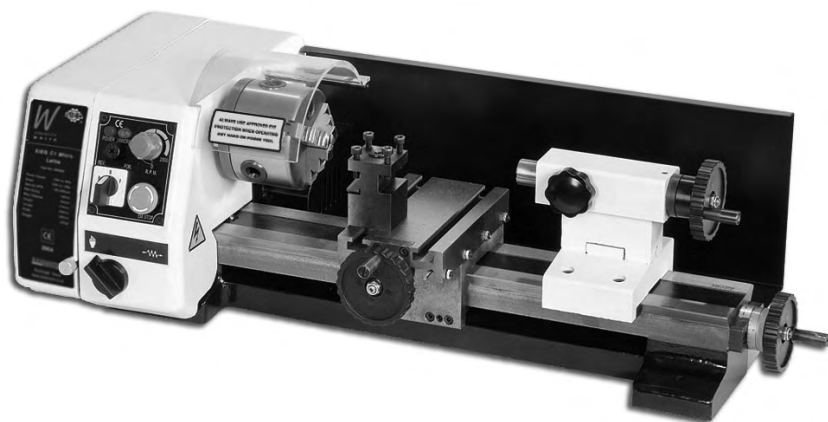

User Manual

600882



Axminster Reference No: **C1**
Mk 2 Part No: **600882**



www.axminster.co.uk

Index of Contents

	Page No.
Index of Contents.....	2
Declaration of Conformity.....	2
What's in the Box.....	3
General Instructions for 230v Machines.....	4
Initial Assembly and Testing.....	5
Testing.....	5-6
Specifications.....	7
Definitions.....	7
Parts Identification and Description.....	8
Machine Illustration of the Micro-Lathe.....	9
Parts Identification and Description (Continued).....	10
Machine Illustration of the Micro-Lathe (Continued).....	11
Parts Identification and Description (Continued).....	12
Machine Illustration of the Micro-Lathe(Continued).....	13-14
Settings and adjustments.....	15
Maintenance.....	16-17
Oiling Points.....	17
Illustrated Parts Breakdown for the Micro-Lathe (Part 1).....	18-19
Illustrated Parts Catalogue for the Micro-Lathe (Part 1).....	20
Illustrated Parts Catalogue for the Micro-Lathe (Part 2).....	21
Micro Lathe (Accessories).....	22
Change Gear Table.....	23



Declaration of Conformity

The undersigned, Ole Stilling authorised
by Shanghai SIEG Machinery Co., Ltd.
No.555 Caofeng Rd., South to No.17
Bridge of Caoan Rd., Shanghai

declares that this product:

Micro Lathe C1

manufactured by Shanghai SIEG Machinery Co.
is in compliance with the following standards or
standardisation documents

**EN55014-1: 2000, EN55014-2: 1997
EN61000-3-2: 2000, EN61000-3-3: 1995**

in accordance with Council Directives
(89/336/EEC amended by 93/68/EEC)



Please read the Instruction Manual prior to using your new machine; as well as the installation procedure, there are daily and periodic maintenance recommendations to help you keep your machine on top line and prolong its life. Keep this Instruction Manual readily accessible for any others who may also be required to use the machine.

What's in the Box?

Quantity	Item	Model Number
1 No.	Micro Lathe with Chuck, Chuck Guard and Tool Post fitted.	C1

Box containing:-

1 No.	Set (3) External Jaws for Chuck
1 No.	8mm Square 'T' Chuck Key
3 No.	Rod Handles (detached for packing)
1 No.	Tailstock Dead Centre (1 x No.1 MT Morse taper)
1 No.	Double Open Ended Spanner 5mm A/F x 5.7mm A/F
1 No.	Nipple 'C' Spanner 28mm-32mm
1 No.	Allen Key 2mm
1 No.	Allen Key 3mm
1 No.	Allen Key 4mm
1 No.	Allen Key 6mm
2 No.	'T' Slot Keepers
1 No.	Oiling Bottle
1 No.	Spare Fuse (230v 1 Amp)
1 No.	Manual
1 No.	Guarantee Card

Having unpacked your machine and its accessories, please check the contents against the equipment list "**What's in the box**", if there are any discrepancies, please contact Axminster Power Tool Centre using the procedures laid down in the catalogue. Please dispose of the packaging responsibly, much of the material is bio-degradable. The machine and its accessories will arrive coated with heavy corrosion preventative grease. This will need to be cleaned from the machine, its components and accessories prior to it being set up and commissioned. Use coal oil, paraffin or a proprietary degreaser to remove the barrier grease. Be warned, it will stain if you splash it on clothing etc., wear overalls, coverall et al., rubber gloves are also a good idea, as is eye protection if your cleaning process tends to be a little bit enthusiastic. After cleaning, lightly coat the exposed metal surfaces of the machine with a thin layer of light machine oil. N.B If you used paraffin/kerosene make sure you apply this thin film sooner rather than later.

General Instructions for 240v Machines

Good Working Practices/Safety

The following suggestions will enable you to observe good working practices, keep yourself and fellow workers safe and maintain your tools and equipment in good working order.



WARNING!! KEEP TOOLS AND EQUIPMENT OUT OF THE REACH OF YOUNG CHILDREN

Mains Powered Tools

Primary Precautions

Primary Precautions

These machines are supplied with a moulded 13 Amp. Plug and 3 core power cable. Before using the machine inspect the cable and the plug to make sure that neither are damaged. If any damage is visible have the machine inspected/repaired by a suitably qualified person. If it is necessary to replace the plug, it is preferable to use an 'unbreakable' type that will resist damage. Only use a 13 Amp plug, make sure the cable clamp is tightened securely. Fuse at 13 Amp. If extension leads are to be used, carry out the same safety checks on them, and ensure that they are correctly rated to safely supply the current that is required for your machine.

Work Place/Environment

The machine is not for working outside, do not use when or where it is liable to get wet. If machine does get wet; dry it off as soon as possible, with a cloth or paper towel. Do not use 240v a.c. powered machines anywhere within a site area that is flooded or puddled, and do not trail extension cables across wet areas. Keep the machines clean; it will enable you to more easily see any damage that may have occurred. Clean the machine with a damp soapy cloth if needs be, do not use any solvents or cleaners, as these may cause damage to any plastic parts or to the electrical components.

Keep the work area as well lit and uncluttered as is practical, this includes personnel as well as material.



(Under no circumstances should CHILDREN be allowed in work areas)

It is good practice to leave the machine unplugged until work is about to commence, also make sure to unplug the machine when it is not in use, or unattended. Always disconnect by pulling on the plug body and not the cable. Once you are ready to commence work, remove any tools used in the setting operations (if any) and place safely out of the way. Re-connect the machine.

Carry out a final check e.g. check the cutting tool, drill bit etc. is securely tightened in the machine, check you have the correct speed and function set, check that the power cable will not 'snag' etc.

Make sure you are comfortable before you start work, balanced, not reaching etc.

If the work you are carrying out is liable to generate flying grit, dust or chips, wear the appropriate safety clothing, goggles, gloves, masks etc. If the work operation appears to be excessively noisy, wear ear-defenders. If you wear your hair in a long style, wearing a cap, safety helmet, hairnet, even a sweatband, will minimise the possibility of your hair being caught up in the rotating parts of the tool, likewise, consideration should be given to the removal of rings and wristwatches, if these are liable to be a 'snag' hazard. Consideration should also be given to non-slip footwear, etc.

Do not work with cutting or boring tools of any description if you are tired, your attention is wandering or you are being subjected to distraction. A deep cut, a lost fingertip or worse; is not worth it!

Do not use this machine within the designated safety areas of flammable liquid stores or in areas where there may be volatile gases. There are very expensive, very specialised machines for working in these areas, **THIS IS NOT ONE OF THEM.**

Check that cutters, drills etc., are the correct type and size, are undamaged and are kept clean and sharp, this will maintain their operating performance and lessen the loading on the machine.

Above all, **OBSERVE....** make sure you know what is happening around you, and **USE YOUR COMMON SENSE.**

Ideally, your lathe should be installed close to a correctly rated power supply, in a warm dry environment, well ventilated and illuminated by bright clear natural light, with adequate access all around the machine, and sufficient adjacent storage space for your tools, accessories and material.

CAN WE DREAM?

The Micro-Lathe is best mounted on a rigid bed, this is to ensure stability of the machine and to attenuate any vibration that is generated when the machine is running, (especially with eccentric work mounted in the chuck, or on the face plate).

The bed should be flat and set level in both planes, and at a height that enables comfortable operation of the machine. It is not necessary to anchor the bed through to the floor, but it must be stable enough to remain immovable during any normal forceful operations (especially tightening) carried out whilst operating your lathe.

If you are preparing your own bed for the machine, it should be at least 500mm long by 210mm wide; (to cover the footprint of the lathe bed and integral splashback). You will need to drill three 6.5mm holes to allow for bolt fixing. Set out the centres of the holes as follows:- (assuming bed size indicated above)

First two holes:-

- **Hole No.1; from the left side of the bed (Headstock side) 50mm,15mm from the front edge of the bed**
- **Hole No.2; from the left side of the bed (Headstock side) 50mm, 100mm from the front edge of the bed.**
- **Hole No.3; 420mm from Hole No. 1,15mm from front edge of the bed.**
- **Bolt the lathe to the bed using M6 bolts and washers.**
- **Locate and identify the 3 rod handles from the packing box. Fit these to the 3 wheel handles, (tailstock control, leadscrew feed, traverse feed).**



Please read the section entitled Identification and Parts description so that you may more easily identify the parts to which reference is made in the text.

When the lathe is mounted to your satisfaction, proceed as follows:-

- a) Close the chuck jaws.
- b) Check the tailstock is 'nipped' and barrel lock is tightened.
- c) Check that all loose items are removed from the lathe.
- d) Set the saddle approximately mid-way along the bed.
- e) Press the Emergency Stop Button IN. (Emergency Stop On.)

Testing (Continued)

- f) Check the Autofeed/Manual Lever is set to manual (Hand logo).
- g) Close the chuck guard.
- h) Check the speed control is switched OFF (fully anti-clockwise).
- i) Check the Forward/Off/Reverse Switch is in the Off position.
- j) Connect the machine to the mains supply and switch power on.
- k) Turn Emergency Stop switch to the right and allow it to spring out and reset.
- l) Check the Green Power LED is illuminated.
- m) Turn the Speed Control Switch On (Clicks On).
- n) Check the Amber LED (Fault Light) is illuminated.
- o) Switch the Speed Control Switch Off (Clicks Off) and the Amber Led is now Off.
- p) Select Forward on the Forward/Off/Reverse switch.
- q) Turn the Speed Control Switch On and advance until the Chuck starts to rotate.
- r) Lift the Chuck Guard, check the spindle stops and the Amber fault LED illuminates.
- s) Reset the Chuck guard, check the spindle does NOT restart and the Amber fault LED remains On.
- t) Turn the Speed Control Switch Off, and that the Amber LED goes off.
- u) Turn the Speed Control Switch ON, advance until the spindle starts to rotate.
- v) Over a period of approximately 5 minutes advance the speed in stages to maximum, run at maximum for at least 2 minutes, check that there is nothing untoward, (no excessive vibration, speed progression is smooth etc).
- w) If all the above checks are correct, stop the spindle, select the autofeed function, (if necessary 'joggle' the lead screw handle to enable the gears to mesh. Switch on and advance to a reasonable speed, check the saddle drives smoothly towards the chuck.
- x) Stop the spindle, select reverse, switch on and advance to a reasonable speed, check the chuck drives smoothly towards the tailstock.
- y) If all the above checks are correct, the final check is to set the spindle running, then hit the Emergency Stop switch. Check the spindle stops and all power indications go Off.
- z) Your lathe is now ready for use. Enjoy.

Specifications

Axminster No.	SIEG C1 MK2 600882
Rating:	Hobby
Motor:	240V 50Hz 150W
Max Swing over the Bed:	140mm
Max Distance Between Centres:	250mm
Spindle Speed (Forward & Backward):	100-2000rpm
Reversing Method:	Electrical
Headstock Taper:	2MT
Tailstock Taper:	1MT
Clear Bore in Headstock Mandrel:	10.5mm
Leadscrew Pitch:	3mm
Thread Pitch Range (Change Wheel Set Req):	0.5,0.7,0.8,1.0,1.25mm
Max Traverse Travel:	60mm
Max Extention of Tailstock Barrel:	22mm
Overall L x W x H:	630 x 330 x 210mm
Weight:	22kg
Please note your lathe is supplied with the following change gears:- 19T, 24T, 76T, & 90T. The fixed gear on the headstock is 36T	

Definitions

Main Axis	This is the axis established through the spindle of the headstock. It is horizontal to and parallel with the lathe bed along its length, as described by the saddle.
Work Axis	This is the axis established by the work piece, it is horizontal to, but not necessarily parallel with, the lathe bed, along its length.
Traverse Axis	This is the axis described by the traverse slide when it is being moved independently of the saddle. It is perpendicular to the main axis in the horizontal plane.
Compound Axis	This is the axis described by the compound slide, if fitted, when it is being operated independently of the traverse slide and the saddle.

Parts Identification and Description

Please take some time to identify the various parts of your machine so that you are familiar with the terminology we will use to enable you to set up and operate your Lathe safely and correctly.

Headstock	The 'engine block' of the lathe, supports the motor, the spindle, the cover for the change gears, the drive belt and the driven end of the leadscrew. It also mounts the control panel for the motor and the selector for the leadscrew.
Change gear cover	Protective cover, enclosing the motor pulley, the drive pulley and drive belt and the change gear.
Motor	220V d.c. motor
Mounting flange	The mounting flange is integral with the spindle and mounts all the material carriers, (chucks, faceplate etc.), it is bored with a No.2 morse taper to accept the headstock centre, The boring is then carried through the complete length of the spindle (10.5mm clear) to allow long lengths of round bar to be machined. Your Micro-Lathe is supplied with a chuck adaptor plate and chuck already fitted to the mounting flange.
Chuck safety cover	A clear acetate cover mounted on a pivot bar on the rear top front face of the headstock. It can be tipped out of the way to access the chuck when it is stationary, and repositioned over the chuck during operation. It is safety interlocked, if it is not in position the motor will not run, or the motor will stop if it is moved whilst the spindle is turning.
Motor control panel	<p><u>Power On LED</u> Green LED that indicates that power is available to the motor. i.e. mains is applied, fuse is intact and the Emergency Stop switch is not activated.</p> <p><u>Fault LED (marked UNNORMAL)</u> Amber LED that indicates that there is a fault or an incorrect control sequence. e.g. the chuck guard interlock has been activated or the speed control is activated without forward or reverse direction being selected. The Motor will not run if the fault LED is illuminated. If the safety interlock is activated, the safety interlock will remain in force until the interlock is reset and the start sequence re-initiated.</p> <p><u>Fuse Cap</u> Access cap for the 20mm fuse cartridge (1 Amp 250V).</p> <p><u>Speed Control Knob</u> Round raised ridge knob connected to the circuit that controls the motor speed (100-2000 rpm).</p> <p><u>Forward /Off/Reverse Switch</u> Three position switch that controls the direction of rotation of the spindle. Forward indicates that the spindle is turning toward the operator; reverse, the spindle is turning away from the operator. The centre OFF position inhibits the spindle from turning in either direction, under motor drive.</p> <p><u>Emergency Stop Switch</u> Red Domed Mushroom switch; if pressed it removes all power to the machine. It is a 'knock off, stay off,' switch. To reset the switch the domed head must be turned clockwise, which will allow the switch to unlatch and 'spring out' and reset itself.</p>

Machine Illustration of the Micro-Lathe

(Chuck & safety cover removed for clarity)

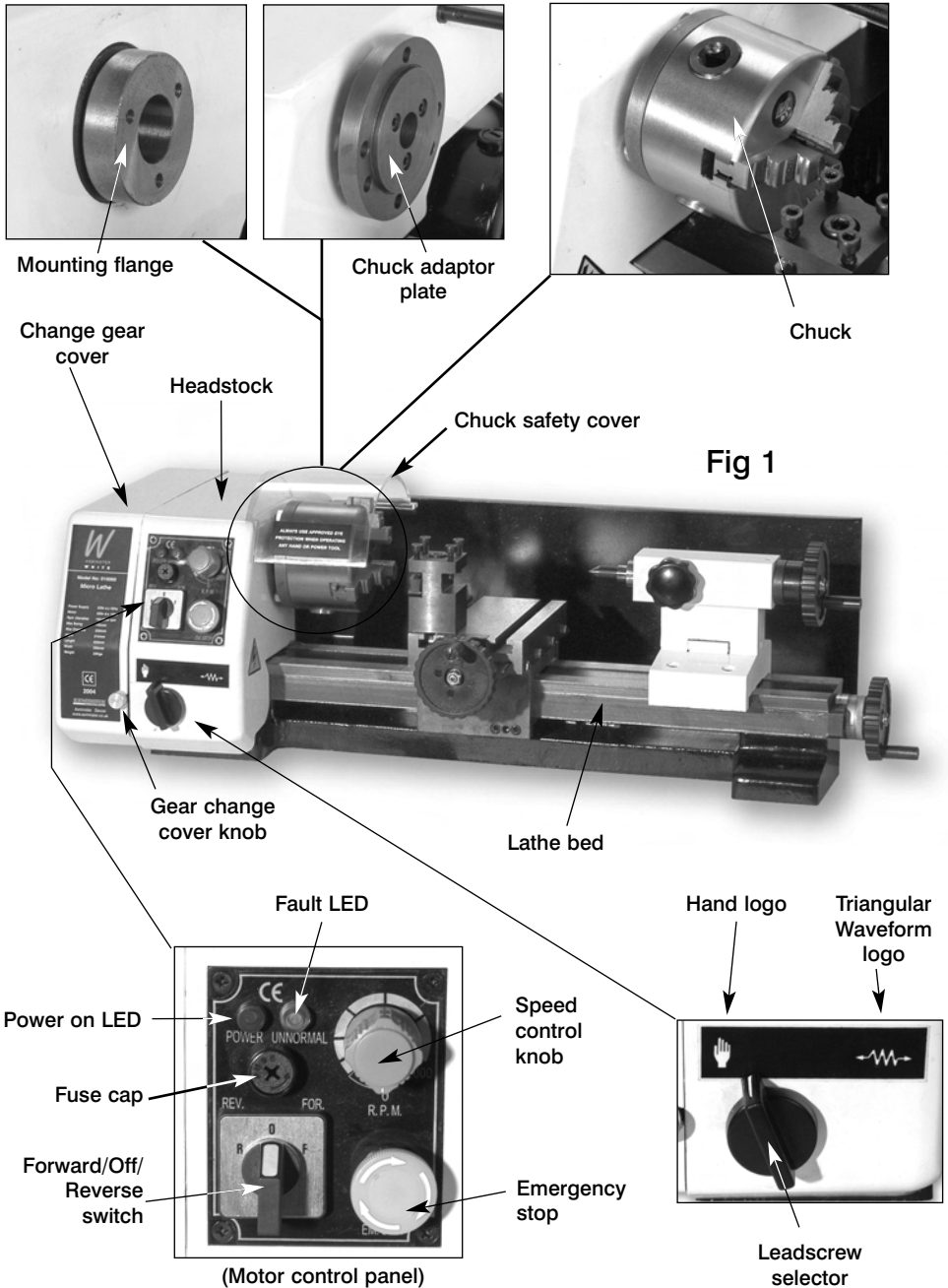

Parts Identification and Description (Continued)

Leadscrew selector	A round centre rib switch/lever, which allows selection of the leadscrew to 'autofeed', i.e driven by the change gear train, (indicated by a triangular waveform sign), or 'manually', i.e. driven by the handle on the end of the leadscrew, (indicated by a 'hand' logo).
Lathe bed	Solid cast, machined bed. The face machining gives two flat bearing surfaces, whilst the ancillary machining gives a dovetail form to the bed, and forms a rigid stable locating and guiding system for all the machines components.
Saddle	Main casting that is precision machined to marry with the lathe bed. It moves parallel to the main axis. It mounts the traverse slide. The accuracy of the fit of the saddle to the bed is maintained by the 'gybe' strip set in the rear of the saddle dovetail.
Traverse slide	Mounted on a 'dovetail' land machined onto the top of the saddle. The accuracy of the fit of the slide is maintained by the 'gybe' strip set in the right hand side of the traverse dovetail slide. The bed of the traverse has two 'T' slots machined into it to allow the mounting of the tool post or the compound slide accessory.
Traverse slide control	A wheel and rod handle, mounted on a shaft that is anchored into a housing machined in the front of the traverse slide, the shaft is threaded and is engaged in a dog fixed to the saddle, enabling the traverse slide to be driven back and forth across the saddle perpendicular to the main axis. There is a graduated ring (thimble) on the neck of the handle to allow the movement of the slide to be measured.
Tool Post	A double sided tool post. Each tool position has 2 securing bolts to clamp the tool in place. One tool mounting has a fixed 'bed' the other has a 'rocking' bed in a curved seating to allow the tool to be tilted slightly fore or back to allow precise tool heights to be achieved, without the necessity for fine shims. The tool post is secured into either one of the 'T' slots by a caphead bolt passing through the tool post into a 'T' slot keeper. The tool post is not keyed into the 'T' slot so it can be turned to any angle before being locked in position.

Machine Illustration of the Micro-Lathe (Continued)

Fig 2

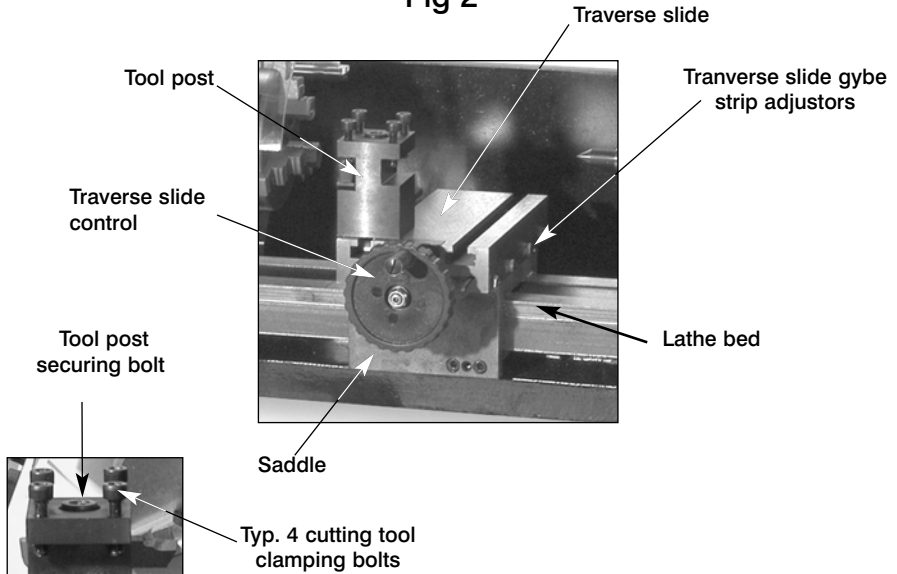
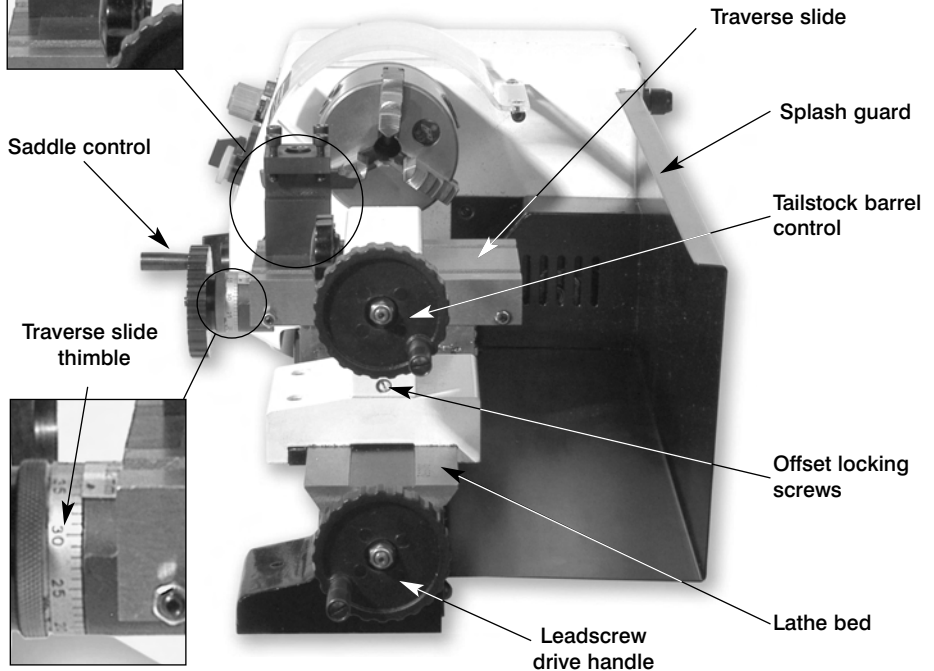

Fig 3



Parts Identification and Description (Continued)

Gear change cover knob	A reeded knob screwed into the front of the headstock, it locates in a slot in the change gear cover, and is used to secure the cover shut. It is unscrewed to release the cover to allow it to be swung open.
Tailstock	A machined casting that accurately fits to the lathe bed. It carries the tailstock barrel. The tailstock barrel is machined with a No. 1 MT, which allows the accessories to be mounted (centers, drill chucks, reamers etc). The tailstock is positioned on the bed by a clamp mechanism at the front of the tailstock body. The clamp is tightened by the two caphead bolts in the front flange of the casting. The Tailstock is capable of being offset to allow for taper turning. The offset locking screw is on the right of the tailstock.
Tailstock barrel control	Wheel and rod handle that controls the backward and forward movement of the barrel in the tailstock. The barrel has a travel of 22mm, to allow the tailstock tooling to be brought into controlled contact with the workpiece, this is indicated on a coarse scale engraved on the barrel itself. The scale indicates -0 and then 20 plus two (x1mm) divisions. The supplied tailstock centre will self eject at -0. The tailstock control has a graduated ring (thimble) mounted on the neck of the handle so that the amount of movement can be measured.
Tailstock barrel lock	Small 'petal' knob that locks the barrel in place once it has been moved into the required position.
Leadscrew	The leadscrew is a threaded shaft that is anchored into a housing machined into the end of the lathe bed. The shaft runs virtually through the centre axis of the underside of the bed, and is engaged in a dog fixed to the underside of the saddle, enabling the saddle to be driven back and forth along the main axis of the bed. The fixed dog is well supported from the front apron of the saddle, and combined with effect of the centralized axis of the leadscrew, results in a very smooth 'judder' free movement. The leadscrew can be driven from either end, from the headstock end, via the change gear train, for auto feed and thread cutting, or manually by the leadscrew drive handle. NOTE The leadscrew is permanently engaged into the saddle dog. Any movement of the leadscrew is transmitted to the saddle.
Leadscrew drive handle	Wheel and rod handle locked onto the end of the leadscrew shaft. Turning the handle will turn the leadscrew and drive the saddle back and forth along the main axis of the lathe. There is a graduated ring (thimble) on the neck of the handle to allow the movement of the saddle to be measured.
Motor securing bolts	Two caphead bolts that screw through the change gear compartment bulkhead and into the motor flange. The holes through the bulkhead are elongated to allow the motor to be moved slightly to maintain the drive belt tension.
Leadscrew oiling point	This is a small hole situated between two caphead bolts on the lower right face of the saddle apron. The oil gallery gives direct access to the leadscrew dog, and enables oil to be spread onto the leadscrew (which is mainly obscured beneath the lathe bed.)
Motor brush caps	Two brush caps located top and bottom of the motor, they are accessed by removing the splash guard.

Machine Illustration of the Micro-Lathe (Continued)

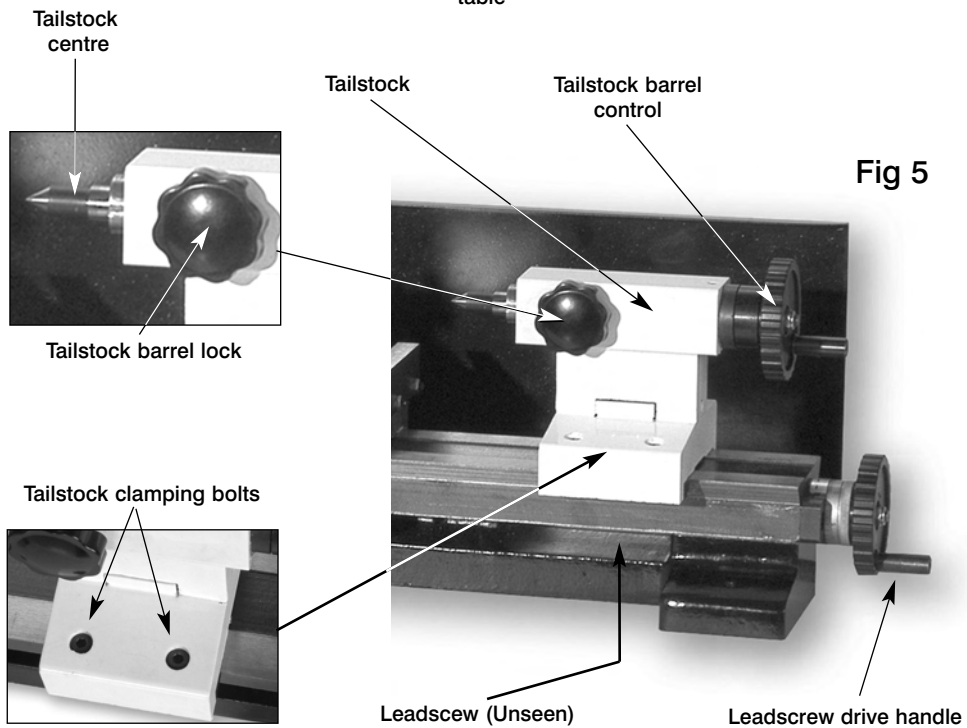
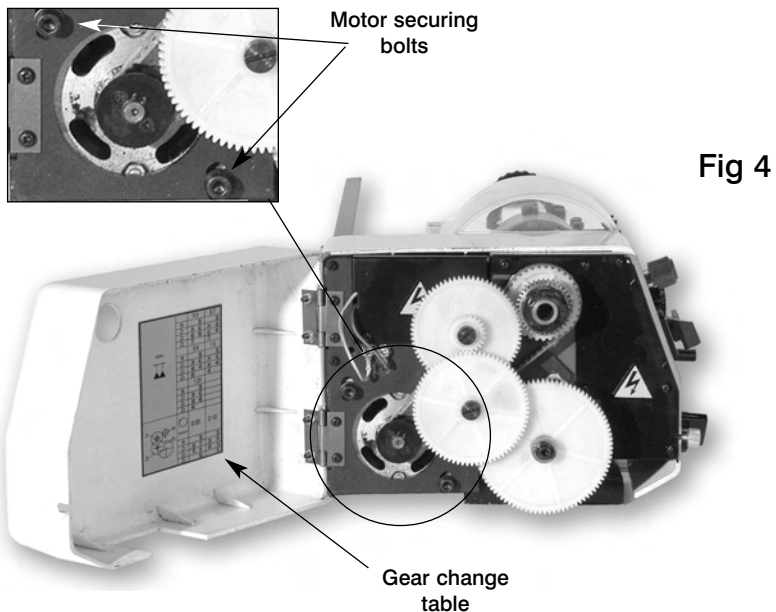
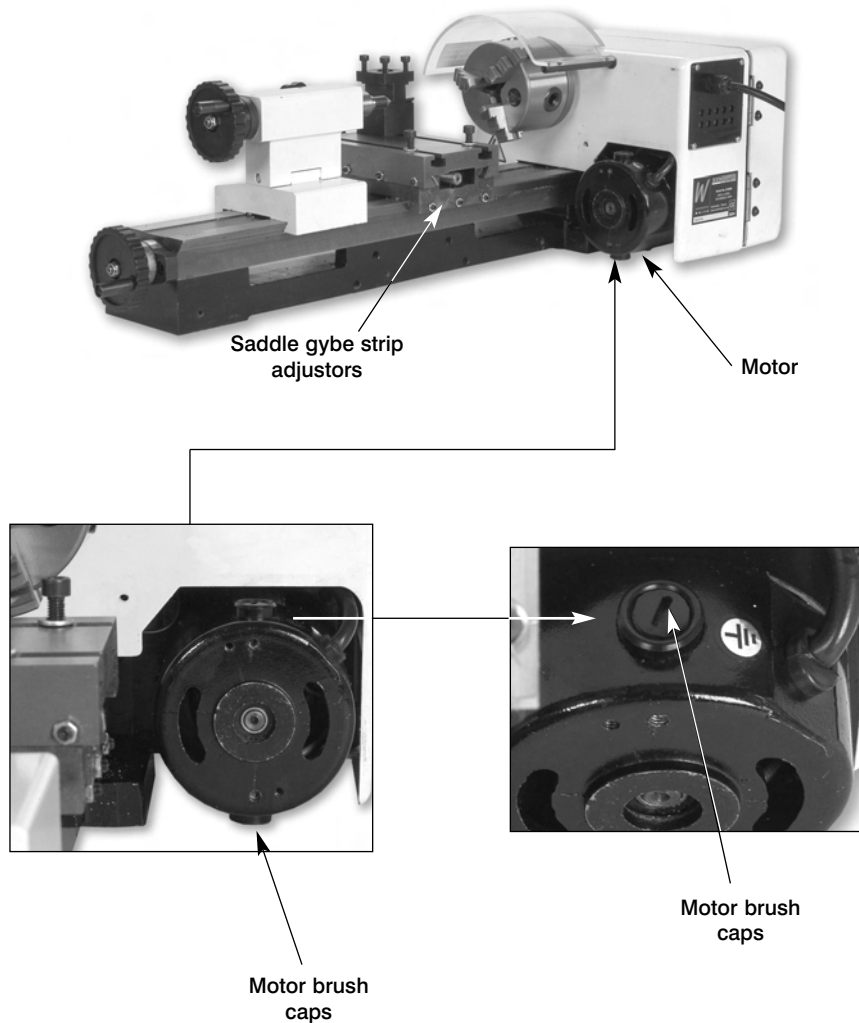

Fig 6

(Splash guard removed for clarity)





Your microlathe has been factory set and adjusted, however, during its life time you may find occasion whereby the lathe needs adjusting to maintain its accuracy and optimum performance. These adjustments can be made as follows:-

Saddle and Traverse slide adjustment

The saddle and the traverse slide are both mounted over dovetail sections. In order to maintain the 'tightness' of the fit; between the sloping surface of the component and its mating surface a gybe strip has been inserted. (At the rear of the saddle, and to the right hand side of the traverse slide).

To adjust the gybe strips, loosen the lock nuts and screw the adjusting screws IN, (4 No. for the traverse slide and 3 No. for the saddle). 'nipping' the component tight to its bedway. Tighten all the screws to the same torque. Check, using the feed handles, that the saddle/slide are locked in place.

Unscrew each adjusting screw by a quarter turn, hold the screw (socket grub screw) in position and tighten the locknut. Check the component now moves smoothly along its bed, using the feed handles. If not, carry out the same procedure, unscrew by a third turn this time, etc, if the movement was too tight; by less than a quarter etc., if the movement became too loose.

Repeat the procedure until the movements are smooth and tight. N.B. Always tighten the locknuts before testing.

Feed scales

The two thimbles that are mounted on the feed shafts of the leadscrew and the traverse feed should move freely with the motion of the handle and not slip. The thimbles can be turned, using more force, independently of the handle in order to set a predetermined start or finish point. If the thimbles are 'slipping' i.e. not maintaining their place relative to the handle, whilst the handle is turning; the cause is almost inevitably dirt, swarf et al., between the pressure plate and the thimble. To rectify this, undo the nut and washer securing the handle to the shaft, remove the hand wheel, and then remove the keyed collar and thimble assembly. Take care that the key does not drop out of the shaft. Gradually separate the thimble from the keyed collar, by twisting and turning, until there is sufficient space to clean the mating surfaces.



BE WARNED The friction drive between the collar and the thimble is effected by a wire spring (like part of a circlip) that is housed in a groove in the collar and rubs against the inside bore of the thimble. If the collar and the thimble are separated too far, the groove and the spring are exposed. The spring can fall out and if not lost, it is awkward to re-compress the spring so that the thimble will slide completely back onto the collar.

Once the mating surfaces are clean, mate the key and the keyway and fit the collar/thimble assembly to the shaft. Refit the washer and the securing nut, and tighten. Tighten until the handwheel, thimble and collar assembly are too tight to move. Undo the securing nut a quarter turn and check that the drive handle rotates freely and there is not excessive backward and forward play in the shaft. (The handle etc, forms one side of the drive screw anchor into the slide).

Maintenance

Your Microlathe is a precision tool. In order to maintain this precision and prolong its useful life, it is advised that you follow the recommended daily and periodic maintenance tables printed below.

Daily

Carry out a visual inspection. Repair any damage immediately. Minor damage to the beds should be taken out with an oilstone.

Move the saddle and the traverse slide back and forth by hand, check that the movement is smooth.

Spread a light film of oil over the bed and the traverse slide bed.

Directly spray oil on the lead screw after every use.

If the lathe is subject to prolonged use, oil the lead screw and bearings every 3-4 hours. **(The lead screw is located underneath and runs the entire length of the lathe bed).**

Daily after -use

1. Clean all swarf and chips away from the machine bed, slide surfaces, and the tool post.
2. Exercise the slides and ensure no swarf etc., is lodged in the drive shaft tunnels. If you have been using a coolant make sure the machine is thoroughly dried off.
3. Check the tool, ensure it is usable for the next time, if not re-sharpen or replace the tool tip.
4. Lightly oil spray all the machine beds and surfaces, and the tailstock barrel.
5. Clean and lightly oil any tools you may have been using (centres, drill chucks, spanners chuck keys etc, and put them away.
6. Switch off the power supply. Disconnect the plug.
7. Cover the machine over with a dust cloth.

Weekly

1. Move the traverse slide fully back to give access to the tunnel, blow out to make sure all swarf is cleared away and heavily spray oil the tunnel, exercise the slide to work the oil into the drive thread and to lubricate the dog.
2. Spray oil the slide and the lathe bed, exercise the saddle and the slide to spread the oil to all surfaces, both hidden and visible.
3. Spray oil under the bed onto the leadscrew.
4. Check the movement of the saddle and the traverse slide, check it is smooth and 'tight', if necessary reset the gybe strips.

Maintenance (Continued)

Monthly

Check the belt tension. If necessary reset the belt tension by loosening the two motor securing caphead bolts, retension the belt and re-secure the bolts.

Every 6 Months

Because the d.c. motor has a heavy permanent magnetic field, it is advisable to dismount the lathe every 6 months, remove the splash guard and remove all the swarf that may have found its way into the motor housing.

Accessories

There are numerous accessories listed for the machine listed in the Axminster catalogue in section 1.

Oiling Points

Fig 7

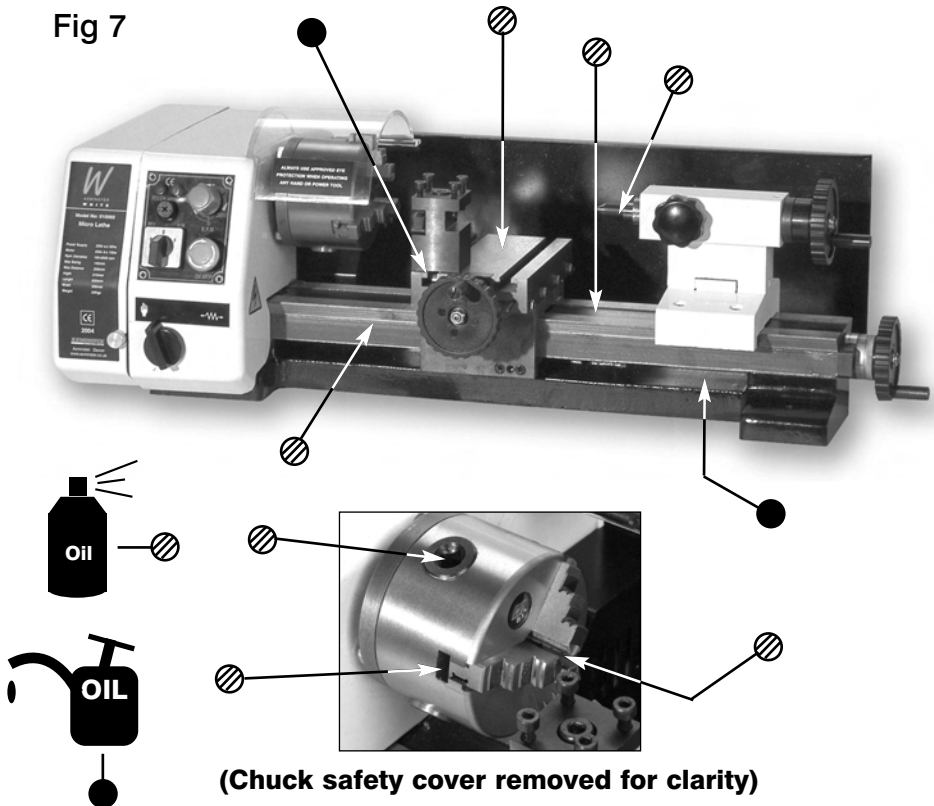

Illustrated Parts Breakdown for the Micro Lathe (Part 1)

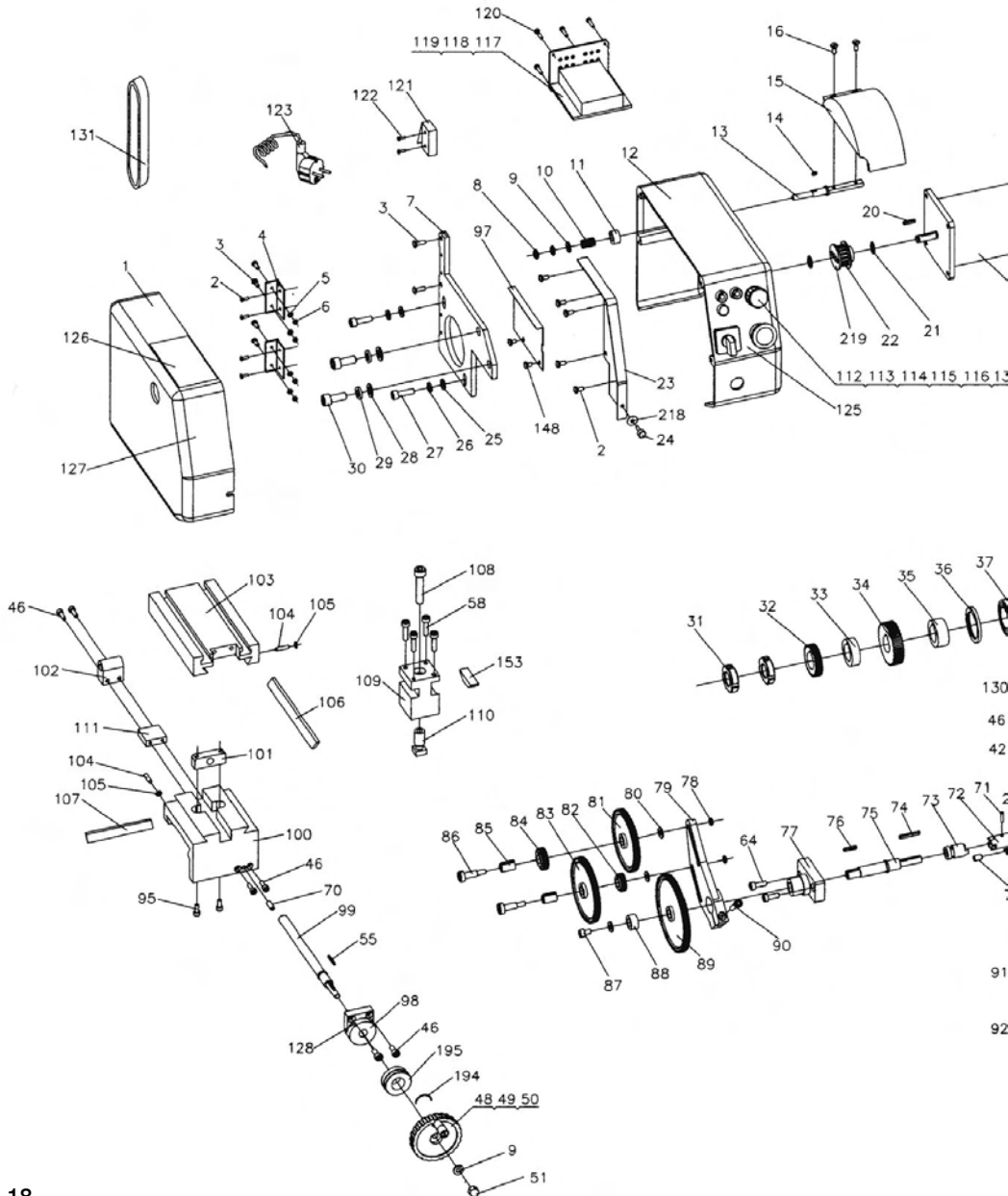

Illustrated Parts Breakdown for the Micro Lathe (Part 2)

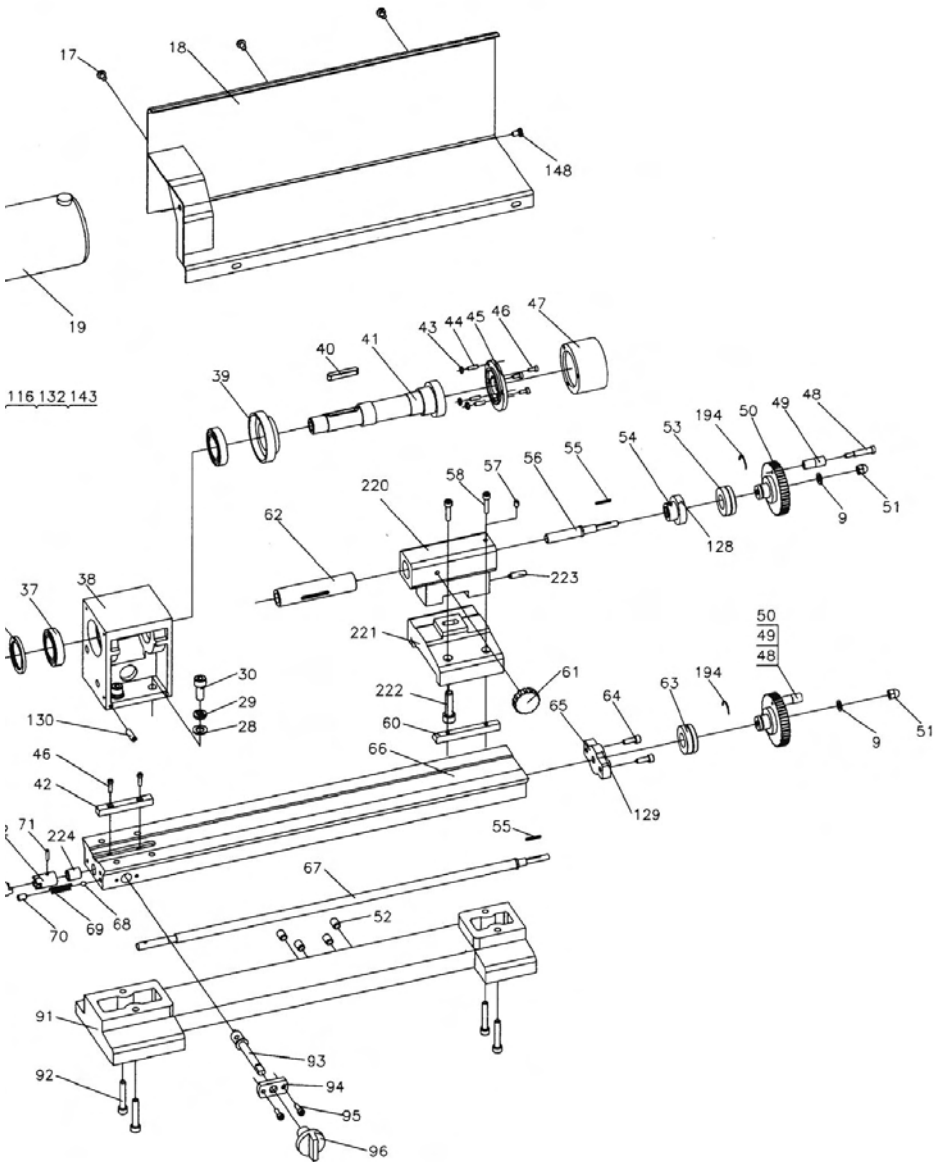

Illustrated Parts catalogue for the Micro Lathe (Part 1)

Item	Part name	Q'ty	Item	Part name	Q'ty
1	Change gear cover	1	51	Cap nut M6	3
2	Cap Screw GB818, M4*8	9	52	Screw M8*12	3
3	Cap Screw GB818, M4*12	6	53	Space ring	1
4	Hinge L*B=38*31	2	54	Screw base	1
5	Washer 4	4	55	Key 2*10	3
6	Nut M4	4	56	Tailstock screw	1
7	Cantilever	1	57	Screw M5*8	1
8	Nut M6	2	58	Screw M5*20	5
9	Washer 6	4			
10	Compression spring	1	60	Wedge	1
11	Spacing ring	1	61	Lock handle	1
12	Cover for Spindle box	1	62	Tailstock quill	1
13	Rotate spindle	1	63	Dial	1
14	Key 3*6	1	64	Screw M5*14	4
15	Protect cover for chuck	1	65	Screw bracket	1
16	Cap screw M4*8	2	66	Bed lead rail	1
17	Cap screw M5*8	4	67	Leadscrew	1
18	Rear splash guard	1	68	Steel ball 5	1
19	Motor	1	69	Compression spring	1
20	Key 3*16	1	70	Screw M6*10	2
21	Check ring 8	2	71	Pin 3*14	1
22	Timing pulley	1	72	Clutch bracket	1
23	Support plate	1	73	Clutch	1
24	Screw M4*8	1	74	Key 3*22	1
25	Washer 6	2	75	Shaft	1
26	Spring washer 6	2	76	Key 3*14	1
27	Screw M6*20	2	77	Gear shaft bracket	1
28	Washer 8	6	78	Nut M5	2
29	Spring washer 8	6	79	Support plate	1
30	Screw M8*20	6	80	Washer	3
31	Small round nut M18*1.5	2	81	Change gear Z=72	1
32	Spindle gear	1	82	Change gear Z=19	1
33	Spacing ring (I)	1	83	Change gear Z=76	1
34	Spindle timing pulley	1	84	Change gear Z=24	1
35	Spacing ring (II)	1	85	Gear sleeve	2
36	Behind oil seal(ring)	1	86	Gear shaft	2
37	Bearing 30205	2	87	Screw M5*8	4
38	Spindle box	1	88	Spacing ring	1
39	Front oil seal(ring)	1	89	Change gear Z=90	1
40	Key 6*36	1	90	Screw M5*25	1
41	Spindle	1	91	Bed base	1
42	Key	1	92	Screw M6*35	4
43	Nut M6	3	93	Unplug shaft	1
44	Screw M6*25	3	94	Dam-board	1
45	Chuck flange	1	95	Screw M4*10	4
46	Round cap screw M4*12	9	96	Clutch rotate knob	1
47	80mm 3-jaw chuck	1	97	Screw M5*12	2
48	Handle screw	3	98	Leadscrew bracket	1
49	Rotate small handle	3	99	Cross slide screw	1
50	Handwheel	3	100	Saddle	1

Illustrated Parts catalogue for the Micro Lathe (Part 2)

Item	Part name	Q'ty	Item	Part name	Q'ty
101	Cross slide nut	1	131	Timing belt 1.5*83*10	1
102	Leadscrew nut	1	132	Change switch	1
103	Cross slide	1	133	Handle bolt	1
104	Screw M4*16	7	143	Reset indicator lamp (Yellow)	1
105	Nut M4	7	148	Spacing ring	1
106	Cross slide wedge	1	153	Screw M6*14	2
107	Gib strip	1	194	Spring	2
108	Screw M8*40	1	195	Dial	1
109	Tool rest	1	218	Big washer	1
110	Tool rest shaft	1	219	Washer	1
111	Connect block	1	220	Tailstock casting	1
112	Potentiometer	1	221	Base plate	1
113	Emergency stop switch	1	222	Screw M8*35	2
114	Forward/off/Reverse switch	1	223	Screw M6*20	2
115	Power indicator light(Green)	1	224	Bearing sleeve	1
116	Fuse box	1			
117	PC board	1			
118	Lock connect	1			
119	PC board box	1			
120	Screw ST2.9*10	4			
121	Micro switch	1			
122	Screw ST1.9*10	2			
123	Power plug	1			
125	Switch label	1			
126	Change gear label	1			
127	Main label	1			
128	Scale label (I)	2			
129	Scale label (II)	1			
130	Screw M5*20	4			

PC Board Replacement Part No:

Part No: 600883

Micro Lathe (Accessories)

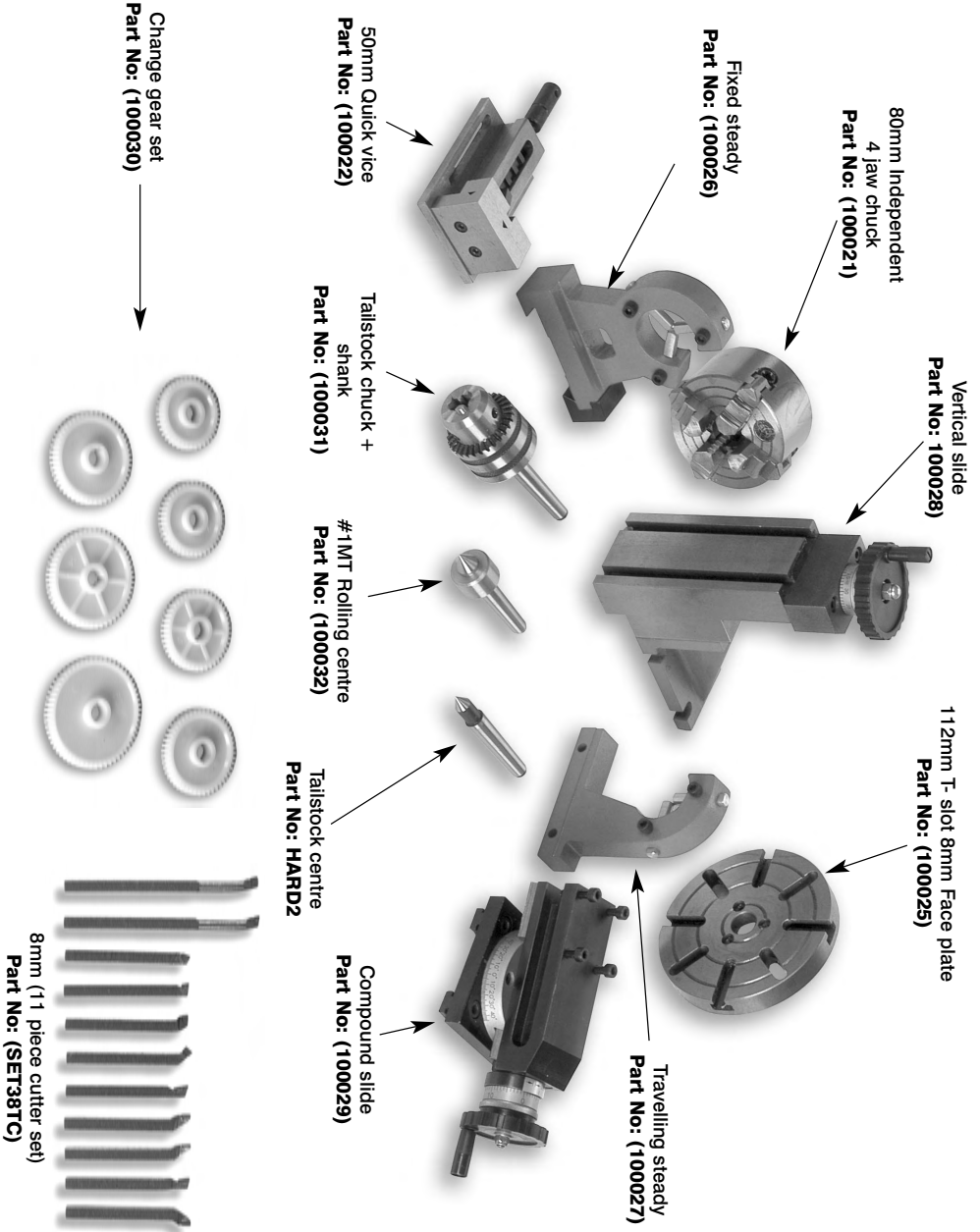

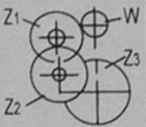

Fig 8

<p>mm</p> 		0.5	0.7
	W	36	36
	Z ₁	24 42	24 40
	Z ₂	40 60	42 45
	Z ₃	72	72
		0.8	1.0
	W	36	36
	Z ₁	24 42	24 42
	Z ₂	40 45	40 48
	Z ₃	60	45
		1.25	
	W	36	
Z ₁	24 42		
Z ₂	50 48		
Z ₃	45		
		0.05	0.10
	W	36	36
	Z ₁	24 72	24 54
	Z ₂	76 19	60 19
	Z ₃	90	76

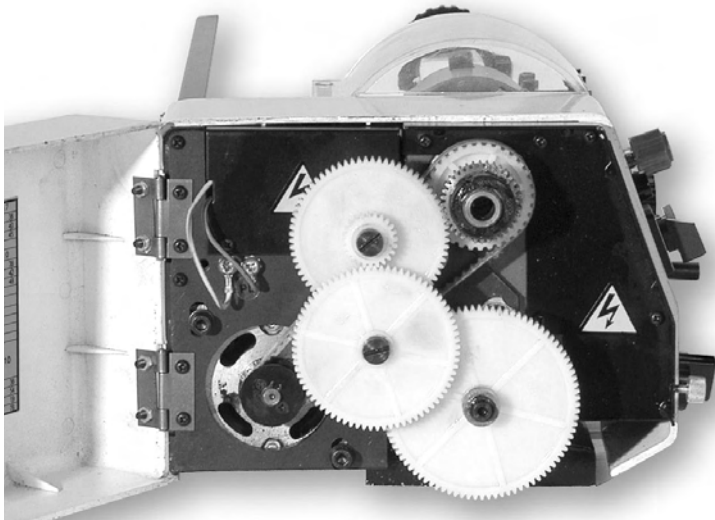

Fig 9



SIEG C1 Micro Lathe Mk2



600882

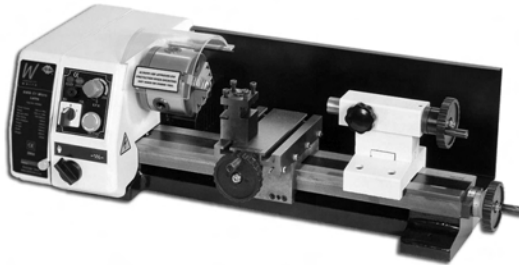

Axminster Reference No: C1
Mk 2 Part No: 600882



AXMINSTER
POWER TOOL CENTRE

Axminster Devon EX13 5PH UK

FREEPHONE 0800 371822



2004

www.axminster.co.uk

