

# SERVICE INSTRUCTIONS

# SCHAUBLIN 70

Machine N° : \_\_\_\_\_

Bl. N° : 341330

Voltage : \_\_\_\_\_

FABRIQUE DE MACHINES  
**SCHAUBLIN S.A.**  
2735 BEVILARD SUISSE

MOUNTING THE 70 LATHE ON A BENCH

The fixing holes necessary for the various beds and the opening for the belts are shown in the sketches below :

Bed for overhead drive 70-10.000

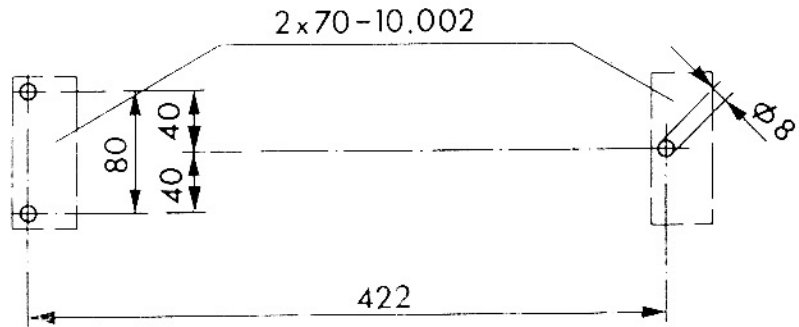

Bed for underneath drive 70-12.000

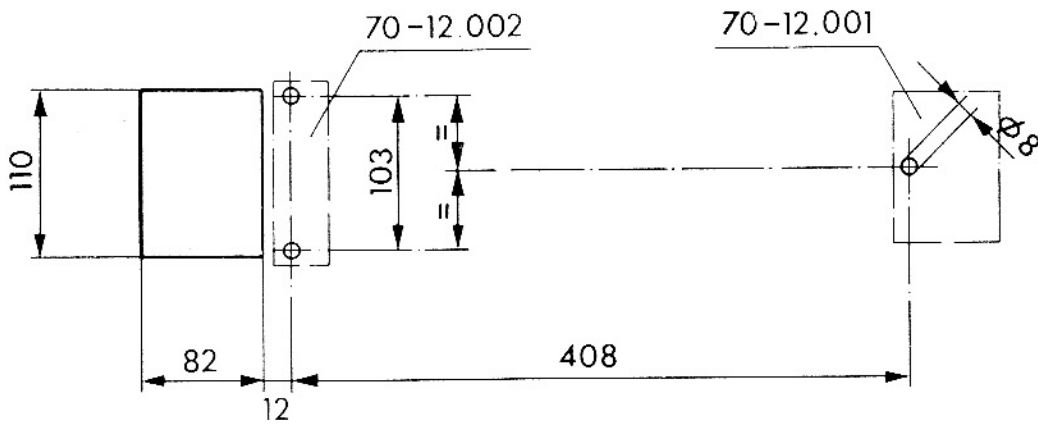

To prevent distortion of the profile of the bed on an insufficiently flat surface, the beds rest on three spherical washers 70-10.003. Two sheetmetal plates are supplied with the lathe. Placed on the bench, they prevent the washers from digging into the wood.

After mounting check with a rule whether the bed is clear of the plates and the bench.

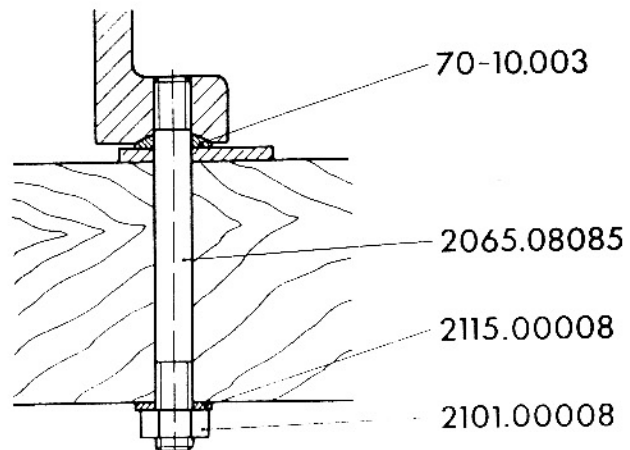

W12 BALL-BEARING-MOUNTED HEADSTOCK

SPECIFICATION

Spindle-nose thread	∅ 22.6 x 2 mm
Length of spindle-nose thread	10 mm
Cylindrical seating of spindle nose	∅ 23 mm
Spindle bore	∅ 12 mm
Maximum throughbore in standard collet	∅ 8.2 mm
Spindel internal taper	15°
Width of pulley steps	19 mm
Diameter of pulley steps	∅ 46/62/78 mm

<u>Article</u>	<u>Designation</u>	<u>Weight</u>
70-30.000	Open headstock + manual drawbar	7.100 kg
70-30.060	Open headstock + quick-closing attachment	8.550 kg
70-31.000	Closed headstock + manual drawbar	8.300 kg
70-31.060	Closed headstock + quick-closing attachment	9.750 kg

The two spindle bearings are preloaded. Consequently it will not be necessary to take up any play.

In normal conditions this preload is maintained throughout the period of lubrication of the bearings.

MAINTENANCE

Cleaning on receipt

Prior to despatch all external and internal machined faces are given a coat of special anti-rust grease.

This grease has no lubricating properties, and its presence may cause serious seizures, even several weeks after commissioning of the machine. Clean the entire unit with a chemically neutral white rag (free from chlorine or acid) soaked in paraffin.

Avoid using alcohol, car petrol (which often contains alcohol), or any other organic product that would dissolve the cellulose paint.

Then cover all bare metal faces with lubricating oil.

Lubricating the spindle bearings and the bearings of the handlever-operated quick-closing attachment

The headstock bearings and those of the quick-closing attachment are lubricated for a period of about 5 years with Klüber Isoflex LDS 18 Speciale A grease.

For any subsequent treatment of the bearings with this grease use preferably the immersion method and select a clean, dust-free location for this purpose.

1. Immerse the bearings in a receptacle filled with 1.1.1 tri-ethane chloride and leave them in this for 1 to 2 hours to allow the old coat of grease to dissolve.

(In the absence of tri-ethane chloride oil of turpentine may be used).

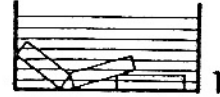

2. Fill a second receptacle with 1.1.1 tri-ethane chloride and shake the bearings in this without turning the races the one against the other.



3. Immerse the thus cleaned bearings in a solution of 70% 1.1.1 tri-ethane chloride and 30% Klüber Isoflex LDS 18 Speciale A.



After evaporation of the solvent the solution, penetrating the smallest crevices, ensures a uniform and lasting coat of grease.

Lubrication by oil gun

The bearing cage 70-30.609 and the pivot of the fork 70-30.612 incorporate nipples for injecting oil by gun.

Once a week inject a few shots of oil through these nipples.

Use a good mineral oil of about 2.5° E / 50° C (for example MOBIL DTE Oil Light).

**DISMANTLING THE HEADSTOCK**

To lubricate or replace the bearings, the headstock must be dismantled. Proceed as follows :

1. Unhook the belt in the base.
2. Loosen the two eccentrics 70-2.007 and 70-2.008 (in the closed headstock) or 70-30.006 (on the open headstock) and withdraw the headstock from the bed.
3. Withdraw the drawbar 70-32.030.
4. Undo the screw 2000.04008, which with the aid of the ring 70-30.624, secures the sleeve of the quick-closing attachment to the spindle.

5. Undo completely the three screws 2020.06020 securing the support 70-30.604 to the headstock frame and remove the entire quick-closing attachment.
6. Undo the four screws 2020.05016 and remove the cover 70-31.021.
7. Unlock the two stop screws 2037.05010 holding the nut 70-36.031 and unscrew this.
8. Undo the three screws 2020.05010 of the baffle plate 70-31.017.
9. Remove the screw 70-31.006 of the pulley 70-31.020.
10. Drive out the spindle 70-31.016 from the rear with a plastic hammer.
11. Remove the bearings.

### SETTING THE BEARING PRELOAD

The fitting of the headstock with freshly lubricated or new bearings is carried out in the reverse order to dismantling (see previous section, items 11 to 7).

Turn the nut 70-36.031 until there is no more play between the bearings.

Then preload the bearings by advancing the nut by 10/1000 mm.

The rotation corresponding to this amount of advance is calculated as follows :

$$\text{Pitch of nut} = 1 \text{ mm}$$

$$\text{Preload} = 10/1000 \text{ mm}$$

$$\text{Rotation of nut} : \frac{1 \times 360 \times 10}{1000} = \underline{3.6^\circ}$$

Measured on the circumference of the nut, this gives a movement of :

$$\frac{\varnothing 45 \times \pi \times 3.6}{360} = \underline{\underline{1.41 \text{ mm}}}$$

Following this adjustment complete the fitting of the headstock. (See items 6 to 1).

### SPINDLE LOCKING DEVICE

The piston 70-30.012 may be engaged in any of the holes in the side of the pulley 70-31.020 with the aid of the knurled knob 70-31.022 (or 70-37.002), thus allowing the spindle to be locked at will.

## LEVER-OPERATED QUICK-CLOSING ATTACHMENT

A. Fitting and method of operation

The bush 70-30.624 of the quick-closing attachment is mounted on the end of the headstock spindle. It is locked by a key 70-30.613 and secured by the screw 2000.04008.

The support 70-30.604 is fixed to the headstock frame by means of three screws 2020.06020. When the lever is pushed to the left, its tip must locate against the screw 2000.06020. If this is not the case, unlock the nut 2101.00006 and adjust the screw 2000.06020.

To clamp the workpiece, pull the lever 70-30.612 to the right (towards you).

To unclamp the workpiece, push the lever 70-30.612 to the left.

B. Setting

1. Pull the lever 70-30.612 towards you.
2. Fit the collet in the spindle with the workpiece.
3. Clamp the workpiece lightly by screwing in the sleeve 70-30.625.
4. Push the lever 70-30.612 to the left and clamp the workpiece fully by means of the sleeve 70-30.625.

The sleeve is automatically locked in all its positions by two spring-loaded pistons 70-30.614.

C. Replacing the closing dogs

Whenever it becomes necessary to replace the closing dogs 70-30.620, it is essential to fit two parts of exactly the same number. To replace the dogs, proceed as follows :

1. Withdraw the drawbar completely with the sleeve 70-30.625.
2. Remove the circlip 2154.00112 and withdraw the bush 70-30.616 by about 1 cm in order to be able to release the two dogs from the slots in the bush.

NOTE : To avoid losing the springs belonging to the pistons 70-30.614, do not withdraw the bush 70-30.616 too far.

3. Place the new closing dogs in position.
4. Refit the circlip 2154.00112 and the drawbar.

D. Fitting the lever-operated quick-closing attachment to a headstock with a quick-closing attachment operated by a standard drawbar

Conversion of the headstock with drawbar-operated closing to a headstock with lever-operated quick closing can be carried out at any time, without difficulty, by any qualified person.

Cleaning on receipt

The lever-operated quick-closing attachment is supplied fully assembled. Prior to despatch it is given a coat of special anti-rust grease, but this must be completely removed before the machine is put into service, since it has no lubricating properties.

Fitting

1. Withdraw the drawbar 70-32.030. This cannot be used for the quick-closing attachment.
2. Place the key 70-21.874 in the slot in the headstock frame.
3. Place the key 70-30.623 in position on the shaft end 70-31.016.
4. Fit the quick-closing attachment by inserting the drawbar 70-30.602 into the spindle 70-31.016.

Make sure that the flat key 70-30.623 enters the slot in the sleeve 70-30.624.

5. Locate the support 70-30.604 against the headstock frame and place the three screws 2020.06020 in position, tightening them lightly.
6. Run the lathe at reduced speed and adjust the eccentric screws 70-30.622 of the lever 70-30.612 until the sleeve 70-30.609 remains stationary in the vertical plane.

NOTE : Any runout in the sleeve 70-30.609, however slight, can cause very rapid wear in the bearing 3062.16007.

7. On completion of adjustment lock the three screws 2020.06020 securely.
8. Lubricate the shoes. (See page 2).

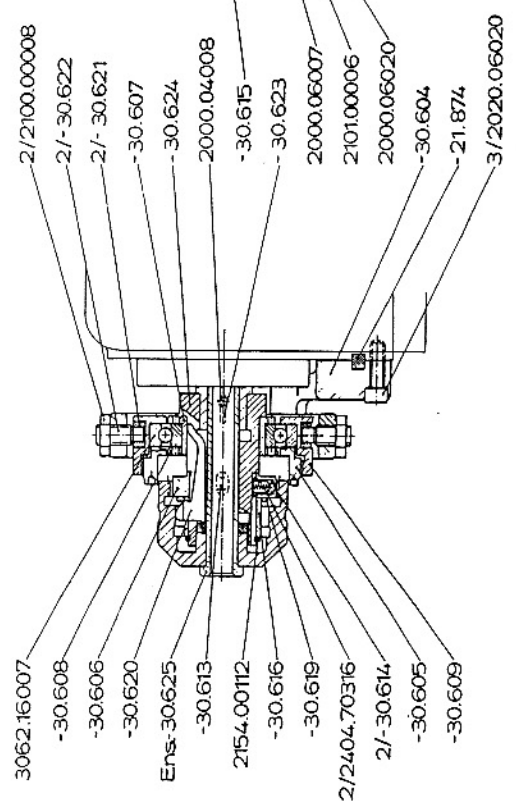
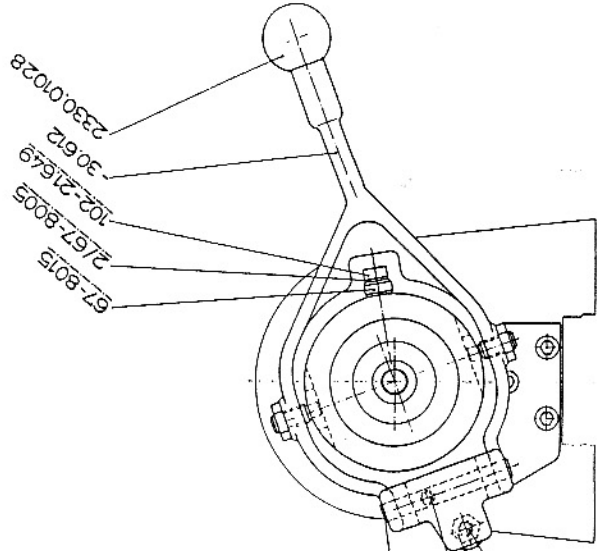
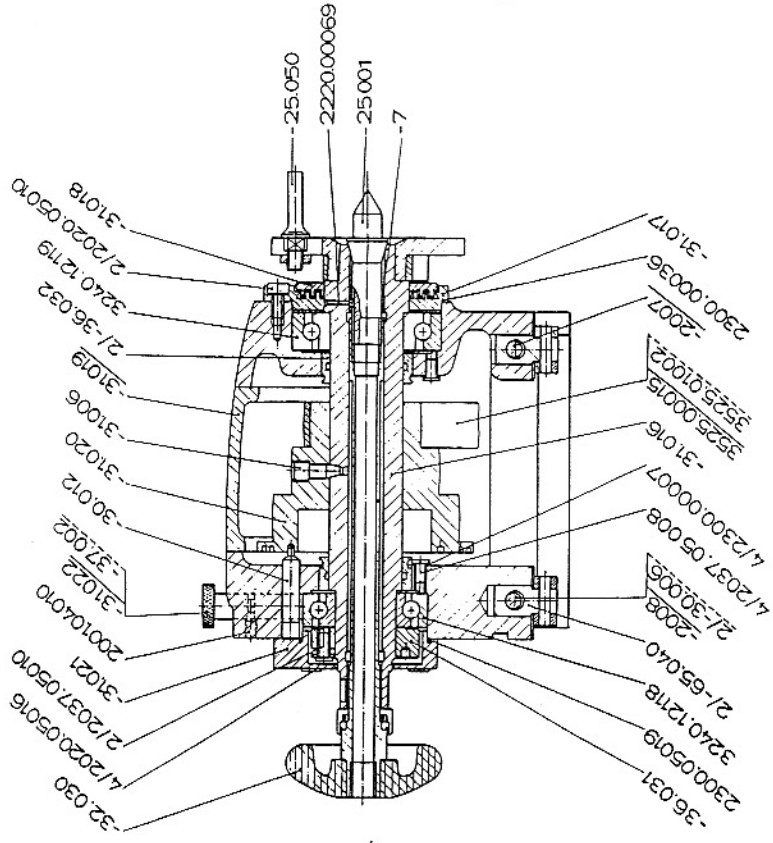
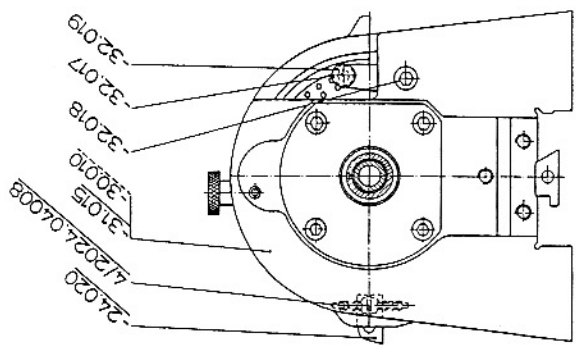

non souligné= toute exécutions  
 — Pces pour pompée fermée  
 - - - - Pces pour pompée ouverte  
 --- Accessoire spécial

- 3062.16.007
- 30.608
- 30.606
- 30.620
- Ens.-30.625
- 30.613
- 2154.00112
- 30.616
- 30.619
- 2/2404.70316
- 2/-30.614
- 30.605
- 30.609
- 2/2100.00008
- 2/-30.622
- 2/-30.621
- 30.607
- 30.624
- 2000.04008
- 30.615
- 30.623
- 2000.06007
- 2101.00006
- 2000.06020
- 30.604
- 21.874
- 3/2020.06020



**SCREW-OPERATED CARRIAGE 70-45**  
for SCHAUBLIN 70 high-precision lathe  
(suitable also for Schaublin 65 lathe with special toolpost)

**ADVANTAGES**

1. Great rigidity and high precision
2. Fully protected slideways with forced-feed lubrication (cleaning action)
3. Micrometer screws supported at both ends; special patented ball bearing at handle end for taking up axial and radial play
4. Patented device for rapid and accurate resetting of swivel base to zero
5. Dovetail on bottom slide for taking and adjustable rear toolholder
6. Harmonious lines and superior finish

**SPECIFICATION**

Longitudinal stroke	60 mm (2 3/8")
Transverse stroke	65 mm (2 9/16")
Accuracy of reading of adjustments	1/100 mm (1/1000")
Top slide swivelling	2 x 90°
Height of centre above carriage	16 mm (5/8")
Swing over carriage	
without rear toolholder	85 mm (3 3/8")
with rear toolholder	45 mm (1 3/4")
Size of tools	8 x 8 mm (5/16x5/16")
Net weight	3.4 kg (7.500 lbs.)

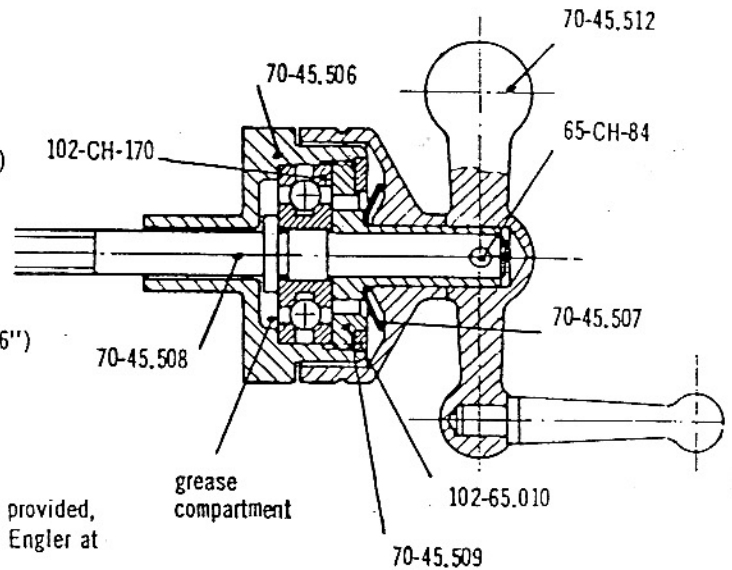
**LUBRICATION****SLIDEWAYS, MICROMETER SCREWS AND NUTS**

Give 4 or 5 shots twice a week through the two nipples provided, using a good light mineral oil with a viscosity of 3° Engler at 50°C.

**BALL BEARING OF MICROMETER SCREWS**

Use a good consistent ball-bearing grease and renew it every 5 years, proceeding as follows :

1. Drive out the taper pin 65-CH-84
2. Withdraw the handle 70-45.512 and the divided drum 70-45.506.
3. Remove the cup spring 70-45.507 and the Seeger clip 102-65.010 and completely unscrew the nut 70-45.509.
4. Remove the ball-bearing ring 102-CH-170 and slightly slacken the screw 70-45.508 in order to be able to fill the compartment with grease. Pack the ball bearing also with grease.

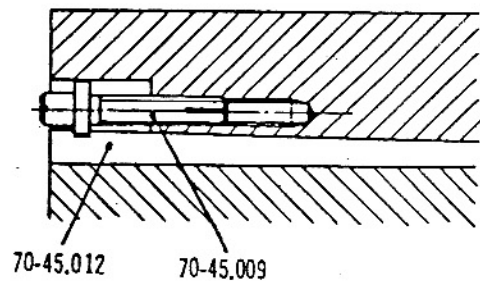

70-45.027

**ADJUSTMENTS****BALL BEARING OF MICROMETER SCREWS**

1. Drive out the taper pin 65-CH-84.
2. Withdraw the handle 70-45.512 and the divided drum 70-45.506.
3. Remove the Seeger clip 102-65.010 and tighten the nut 70-45.509 according to the amount of play to be taken up.

**PLAY IN SLIDES**

A taper gib 70-45.012 is fitted to each of the slides. Play caused by wear in the slideways can be taken up by tightening the adjusting screw 70-45.009 as required.

**DEVICE FOR RESETTING SWIVEL BASE TO ZERO**

1. Fix the carriage securely in correct position on the bed.
2. With the aid of a dial indicator, position the top slide exactly at 90°.
3. Unlock the screw D M4 x 4.
4. Turn the knurled knob 70-45.007 until the end of the rod 70-45.027 is resting against the stop 70-45.017 and then retighten the screw D M4 x 4 securely.

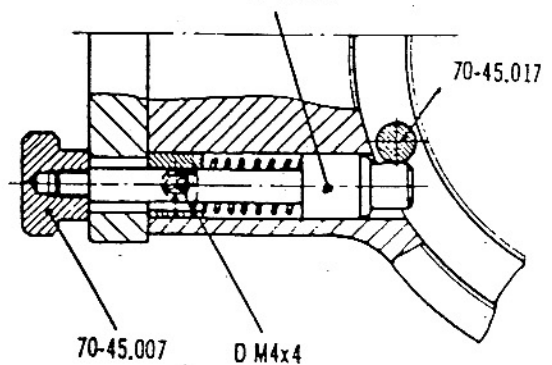



TYPE 70-96 INDIVIDUAL DRIVE FOR «SCHAUBLIN 70» BENCH-MOUNTED LATHE  
with belt-tensioning attachment 70-95.100 for grinding and milling attachments

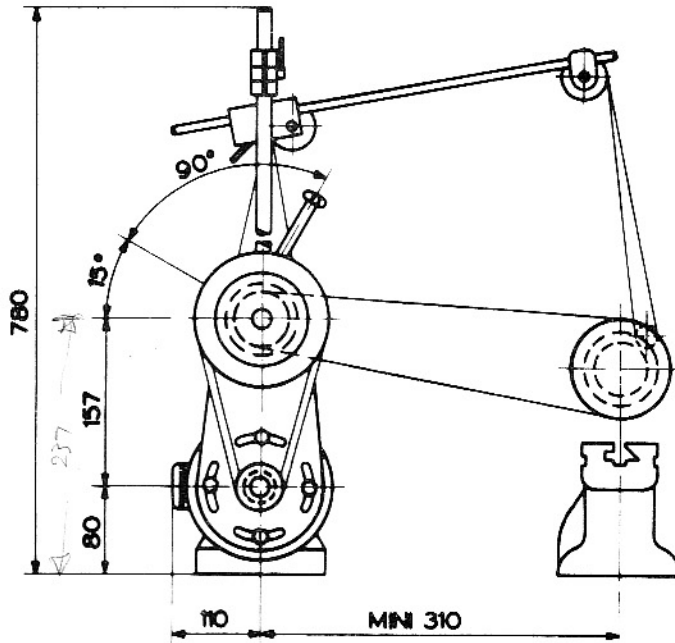

Three types available :

- 70-96.000
- 70-96.100
- 70-96.250

For specification  
see overleaf

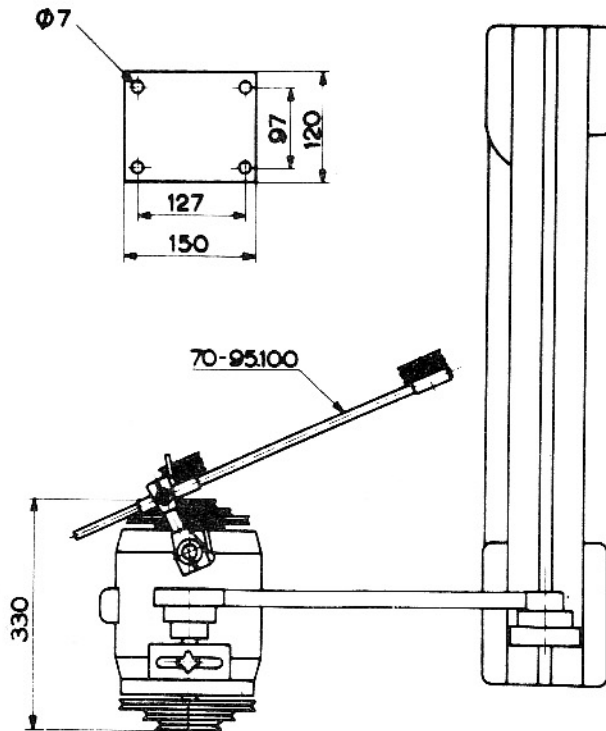

5.7.60 MD/MCh

FABRIQUE DE MACHINES **SCHAUBLIN S.A.** BÉVILARD/SUISSE

Printed in Switzerland

## SPECIFICATION

Item N°	Three-phase motor, 50 cycles			Weight kg (lbs)
	Type	Horse- power	rpm	
70-96.000	Single-speed with switch 70-96.001	0.4	1500	17 (38)
70-96.100	Two-speed, pole-changing, with switch 70-96.101	0.3/0.4	750/1500	17 (38)
70-96.250	Two-speed, pole-changing with switch 70-96.101	0.4/0.6	1500/3000	17 (38)

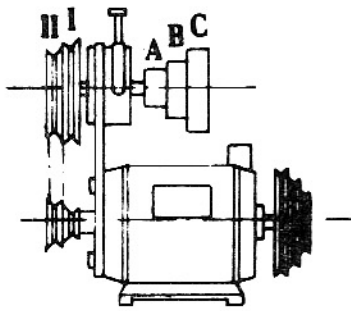

TABLE OF SPINDLE SPEEDS

Valid for all headstocks  
types W10 - W12 - F12 - F16

Motor		A	B	C
750 rpm	I	130	220	370
	II	345	580	975
1500 rpm	I	260	440	740
	II	690	1160	1950
3000 rpm	I	520	880	1480
	II	1380	2320	3900

FABRIQUE DE MACHINES **SCHAUBLIN S.A.** BÉVILARD/SUISSE