

---

# TOUR À VIS-MÈRE SCHAUBLIN 102 VM

## INSTRUCTIONS DE SERVICE

A remettre à la personne chargée de la conduite de la machine.

La reproduction du texte ainsi que des dessins et des clichés est interdite. Les cotes, poids et illustrations ne sont donnés qu'à titre d'indication et nous nous réservons la possibilité d'apporter toutes modifications à la construction.

Mach. N° : 1518.....  
BL N° : 139057.....  
Tension : 220V.....

---

FABRIQUE DE MACHINES **SCHAUBLIN S.A.** BÉVILARD/SUISSE

---

**TOUR À VIS-MÈRE DE GRANDE PRÉCISION  
SCHAUBLIN 102VM**

**CARACTÉRISTIQUES PRINCIPALES**

Hauteur de pointes	mm	102
Distance entre pointes	mm	500

**POUPÉE POUR PINCE TYPE W20**

Alésage de l'arbre	mm	20
Passage de barre en pince	mm	14,5 - 9/16"
Diamètre maximum de serrage	mm	20
Largeur des gradins de poulie	mm	32
Diamètre des gradins de poulie	mm	75 - 100 - 125
Vitesses normales de la broche (voir tableau page 5)	t/ min.	40-3000
Pour vitesses plus élevées, prière de nous consulter		
Réducteur à engrenages, rapport		1 : 5

Sur demande, le tour est livré avec la poupée pour pincé type W25,

Passage de barre en pince 19 mm. Diamètre maximum de serrage 25 mm. La poupée peut également être équipée d'un arbre avec nez américain «Camlock» D1-2" prenant des pinces type W20

**CHARIOT**

Course maximum sur le banc	mm	490
Course coulisseau transversal	mm	110
Course coulisseau longitudinal	mm	90
Précision des lectures sur tambours divisés	mm	1/ 100
Diamètre admis au-dessus du chariot	mm	130
Hauteur de pointe au-dessus du chariot	mm	20
Dimensions des burins	mm	10 x 12
Passage maximum dans la lunette fixe	mm	65
Passage maximum dans la lunette à suivre	mm	40
Avance du chariotage par tour de broche	mm	0,016 - 0,025 0,033 - 0,052 0,077 - 0,117

Avances plus grandes par l'emploi des roues de rechange

**CONTRE-POUPÉE**

Cône intérieur de la broche	mm	2°
Course de la broche	mm	70
Déplacement latéral (de chaque côté)	mm	12

**MOTEUR À FLASQUES À PÔLES COMMUTABLES**

Puissance	CV	0,8/1,5
Vitesses à vide	t/ min.	750/3000

POIDS	net	kg	610
	brut	kg	760

ENCOMBREMENT (long. - prof. - haut.)	cm	152 x 60 x 123
--------------------------------------	----	----------------

EMBALLAGE (dimensions extérieures de la caisse)	cm	175 x 90 x 150
---	----	----------------



Tableau des vitesses

Position de la courroie trapézoïd	Pos. de la courroie plate	Vitesses du moteur					
		750 t/min			3000 t/min		
		A	B	C	A	B	C
I	Avec réducteur sur poupée et réducteur 102 VM 81.100	8	14	24	34	55	90
	Avec réducteur sur poupée ou réducteur 102 VM 81.100	40	70	120	170	270	450
	Sans réducteurs	210	350	590	840	1400	2300
II	Avec réducteur sur poupée et réducteur 102 VM 81.100	10	18	30	45	70	120
	Avec réducteur sur poupée ou réducteur 102 VM 81.100	55	90	150	210	360	580
	Sans réducteurs	270	450	750	1100	1800	3000

Les vitesses sur fond gris appartiennent à la gamme normale obtenue avec le renvoi simple.

Lorsque le réducteur 102-81.100 est utilisé à la place du renvoi normal, il est possible, sans déplacer les courroies et avec la poupée en marche, de sélectionner les vitesses du tableau dans les rapports 1 : 4 (moteur), 1 : 5 (réducteur) et 1 : 20 avec moteur et réducteur simultanément.

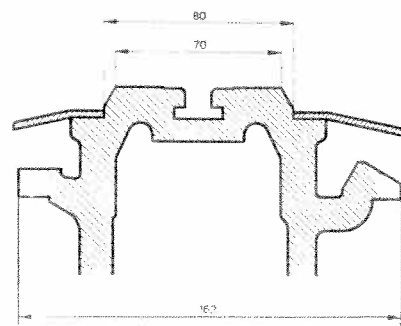
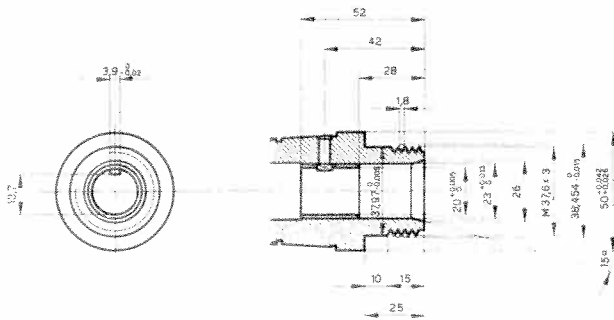
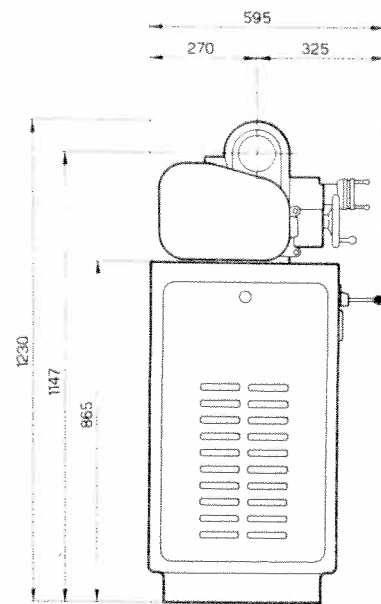
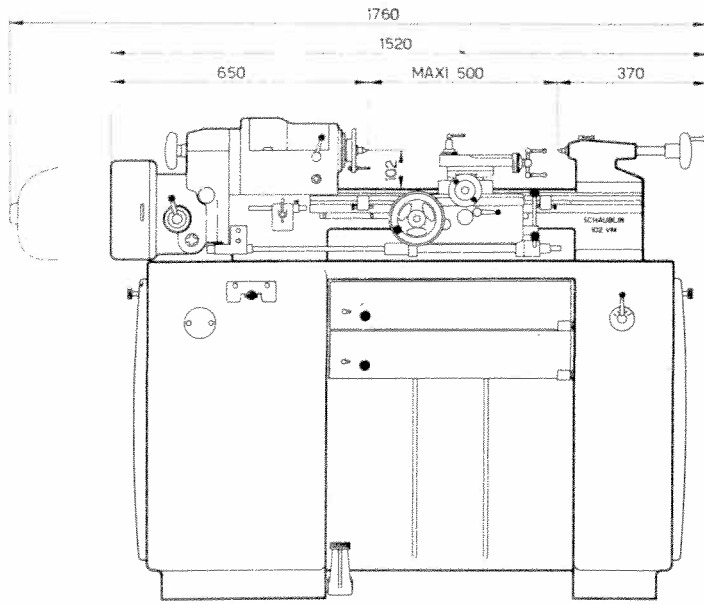
# TOUR 102VM

# POUPEE A ENGRENAGES SUR ROULEMENTS

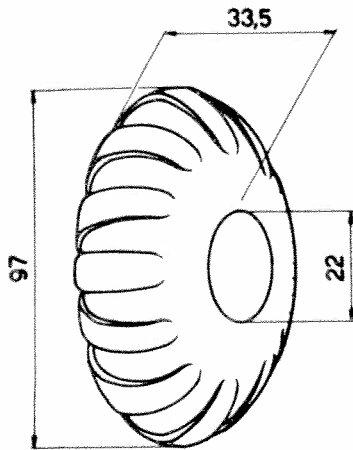

Poulet 102-P20-586b

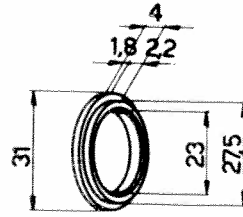

Bague 102-P20-10

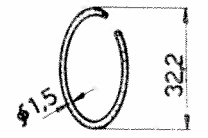

Ressort 102-P20-11

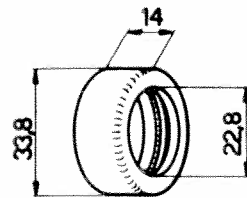

Bague 102-P20-9

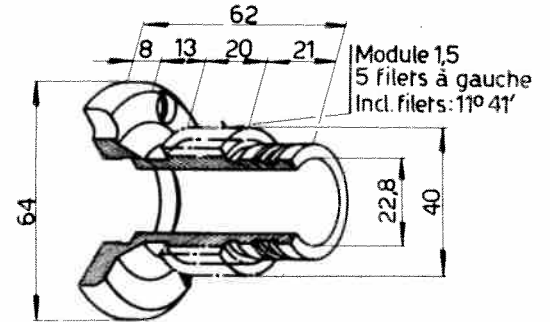

Vis-sans-fin 102VM-103

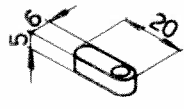

Clavette 102VM-156

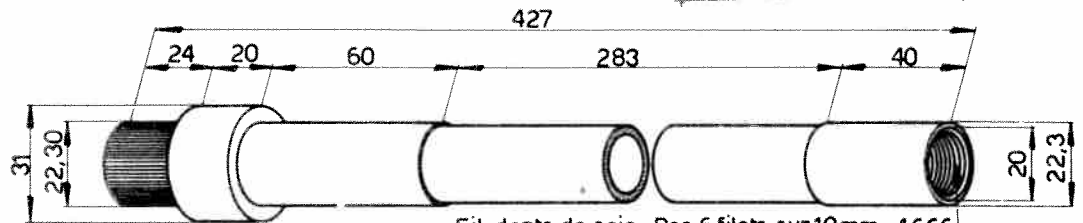

Fil. dents de scie. Pas 6 filets sur 10mm = 1,666

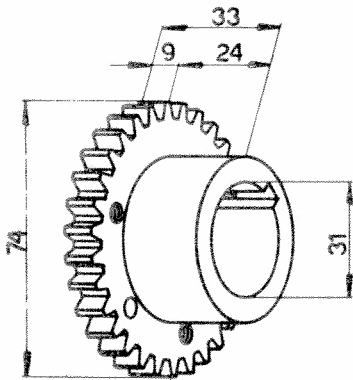

Roue dentée 102VM-104

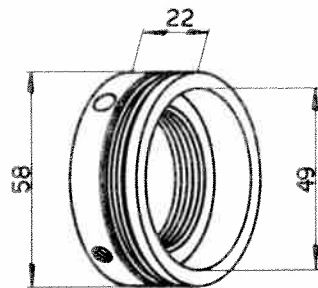

Ecrou-chicane 102VM-6175

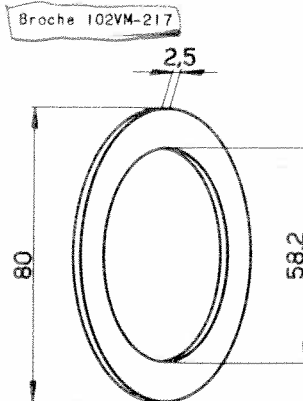

Broche 102VM-217

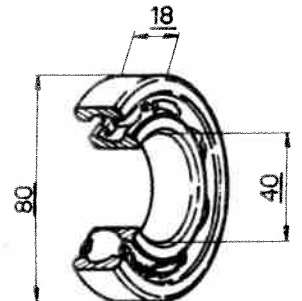

Roulement à billes SKF 6208-C153

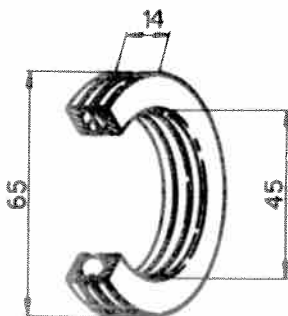

Butée à billes SKF 51109-C05

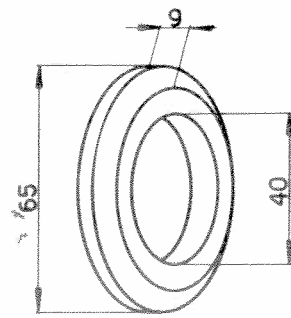

Bague 102VM-215

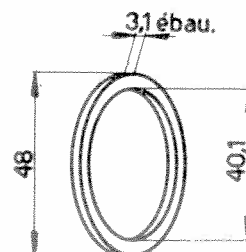

Bague 102-PER20-12

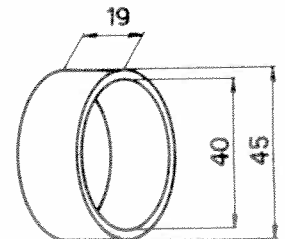

Bague 102-PER20-11

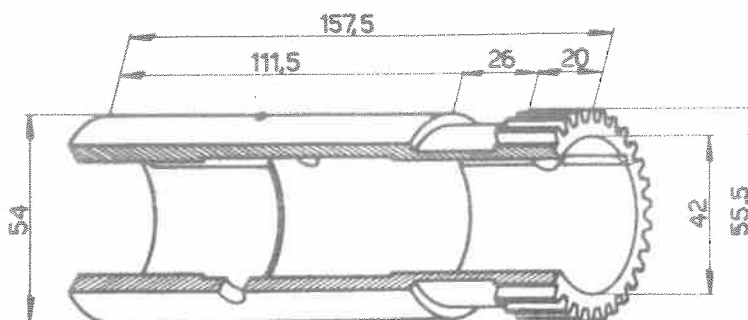

Douille 102VM-213

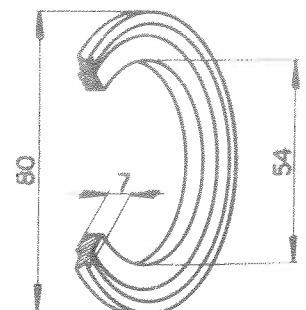

Bague 120 PER-14

# TOUR 102VM POUPE A ENGRENAGES SUR ROULEMENTS

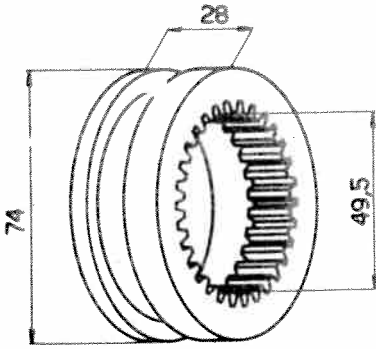

Engrenage 102-PER20-19

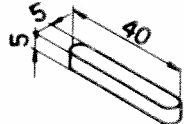

Clavett: 102VM-220

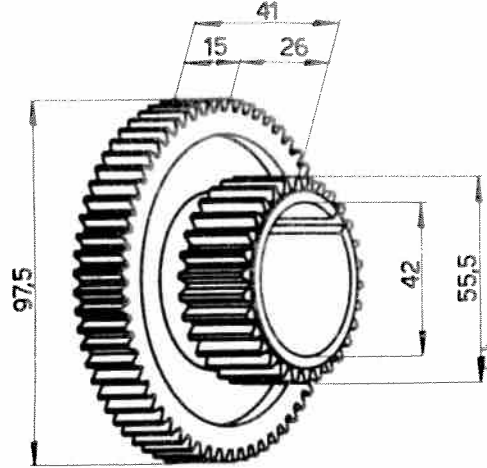

Engrenage 102-PER20-20

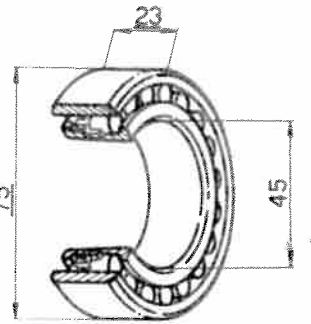

Roulement à rouleaux SKF NN3009K-C021

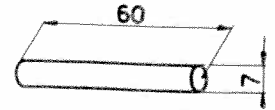

Tige 102-606-0

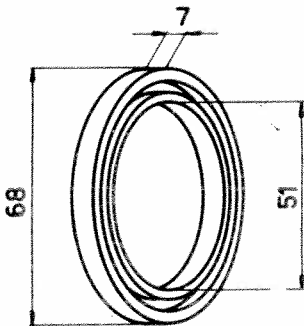

Bague 102-PER20-7

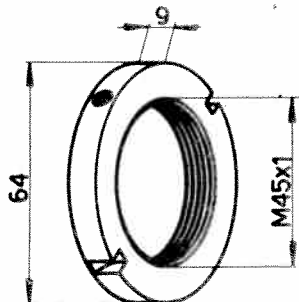

Ecrou 102-PER20-9a

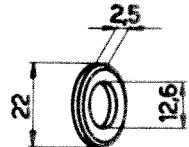

Rondelle 102-606-R

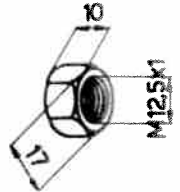

Ecrou 102-606-P

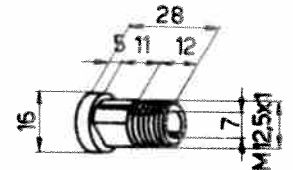

Douille 102-606-N

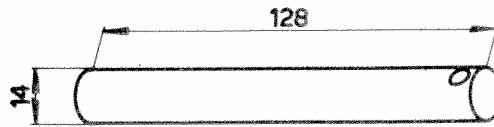

Axe 102-PER20-22

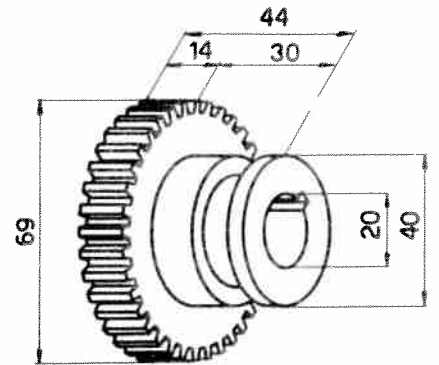

Engrenage 102-PER20-23

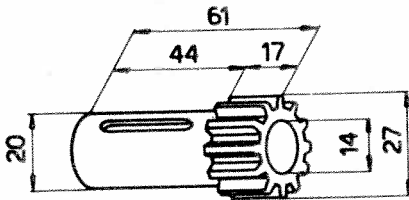

Pignon 102-PER20-21

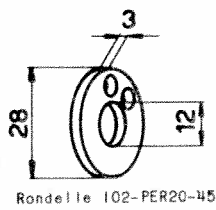

Rondelle 102-PER20-45

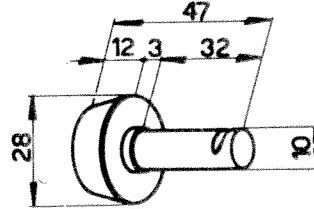

Axe 102VM-6083

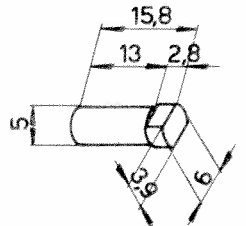

Ech. 2:1  
Prisonnier 102-PER20-8



Ech. 2:1  
Doigt 102-PER20-25

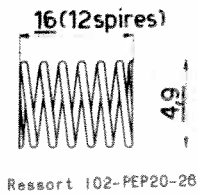

Ressort 102-PEP20-26

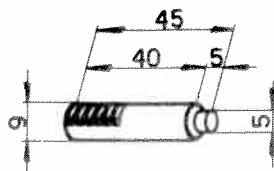

Piston 102VM-168

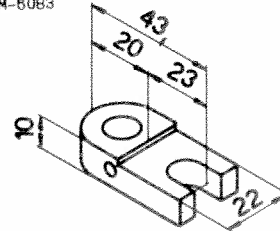

Levier 102-PER20-17

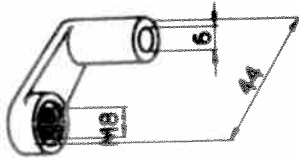

Levier division 102-605-B

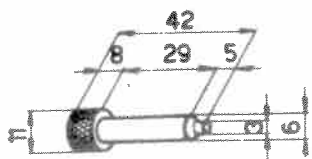

Piston 102-605-P

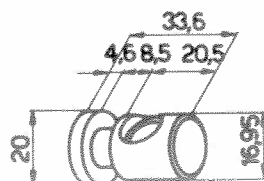

Tirant 102-605-S1

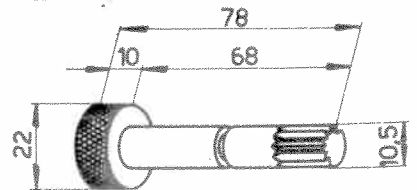

Pignon 102VM-163

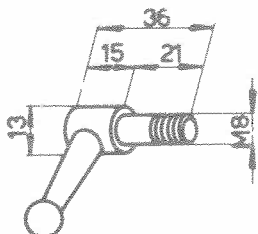

Vis de blocage 102VM-141  
Poignée M63-402 8x10x45

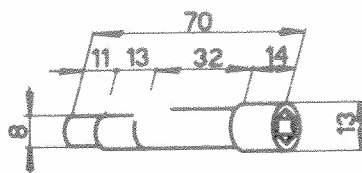

Eccentrique 102VM-356

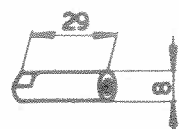

Pivot 102VM-218

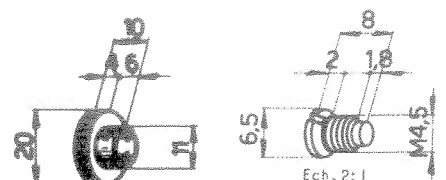

Couvercle graissage 65-P-50

# TOUR 102 VM

# Banc et commande de filetage

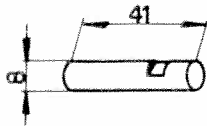

Pivot 102VM-6117

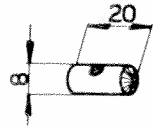

Piston 102VM-6119

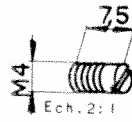

Vis 102VM-6120

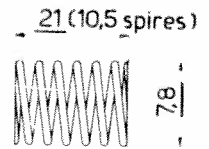

Ressort 0078-39

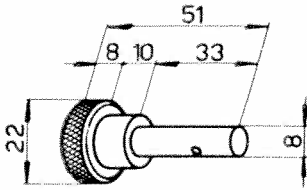

Poullet 120VM-11

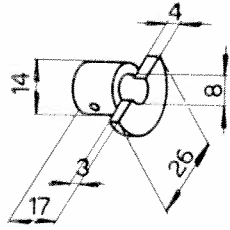

Verrou 120VM-742

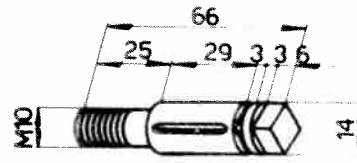

Tourillon 102VM-1712

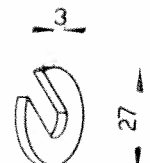

Rondelle à fourche 102VM-1715

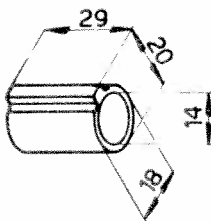

Douille à ergot 102VM-1713

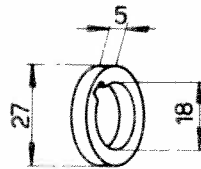

Bague Intermédiaire 102VM-1714

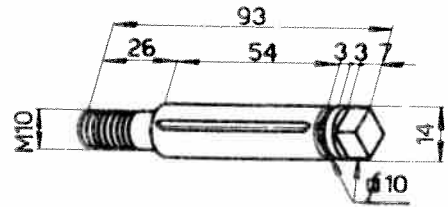

Tourillon 102VM-1720

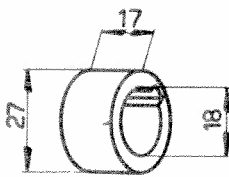

Bague 102VM-1716

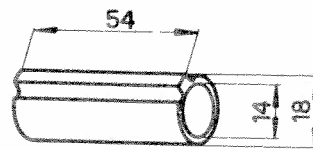

Douille à ergot 102VM-1721

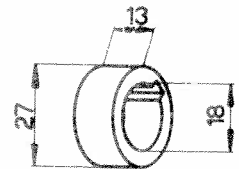

Bague 102VM-1723

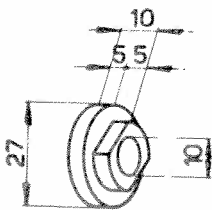

Rondelle à portée 102VM-1711

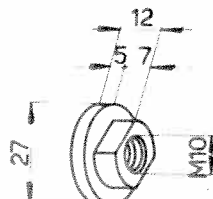

Ecrou 102VM-1710

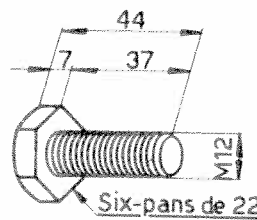

Vis 102VM-6094

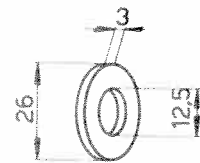

Rondelle 102VM-6095

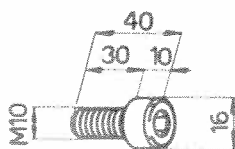

Vis CCM M10x30 462-270

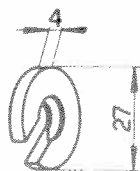

Rondelle-fourche 102VM-1709

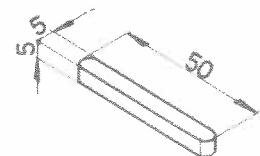

Clavette 102VM-6093

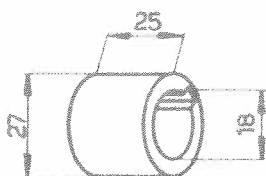

Bague 102VM-1717

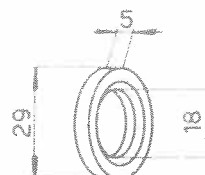

Bague 120VM-412

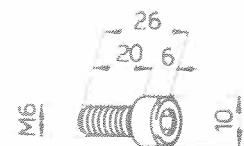

Vis CCM M6x20 462-270



# TOUR 102VM    TABLIER-CHARIOT

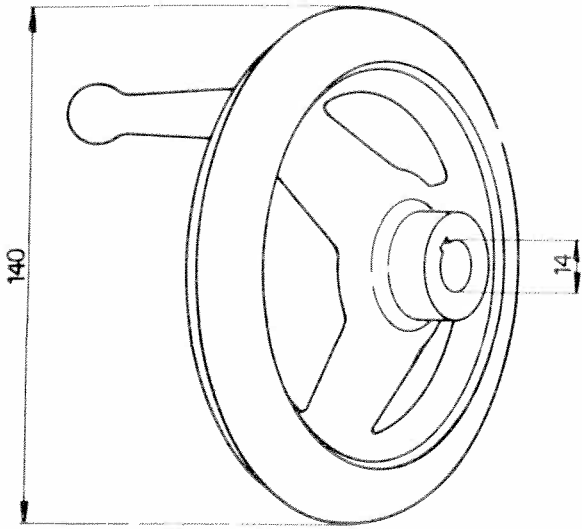

Volant 102VM-780  
Poignée 463-402 10x18x70

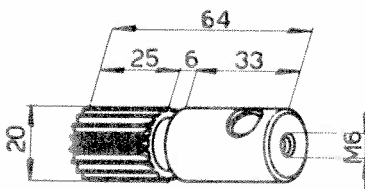

Pignon 102VM-788

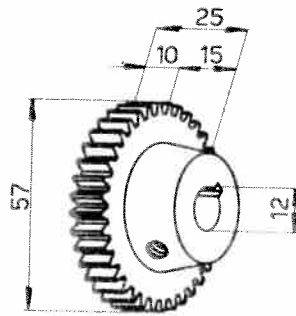

Engrenage 102VM-759

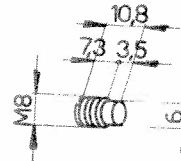

Vis à piv- 02VM-808

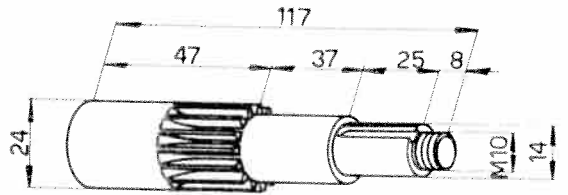

Pignon 102VM-757

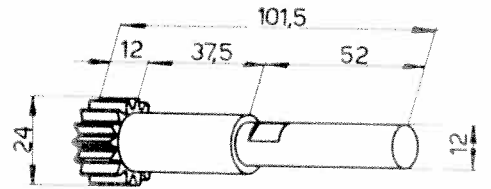

Pignon 102VM-760

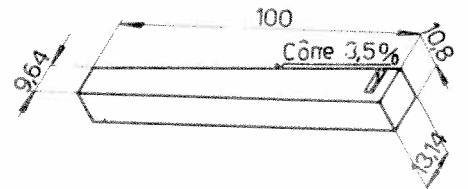

Lardon 102VM-829

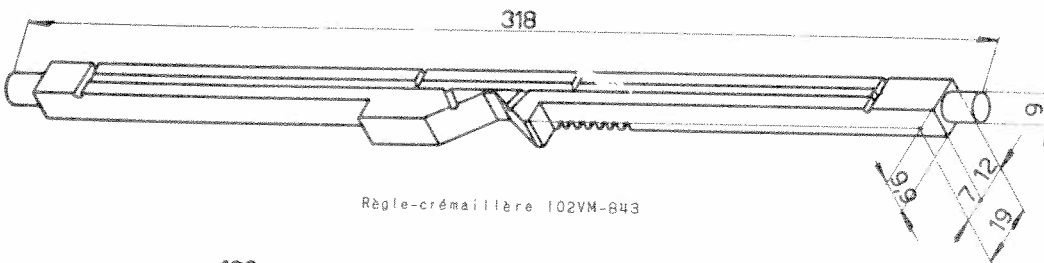

Règle-crémaillère 102VM-843

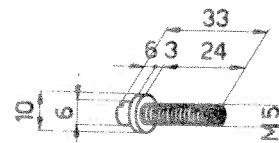

Vis pour lardon 11-33

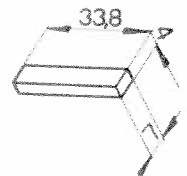

Clavette 102VM-802

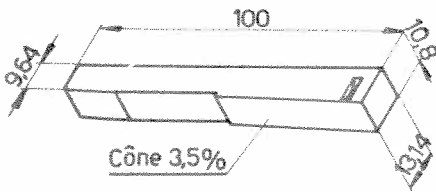

Lardon 102VM-830

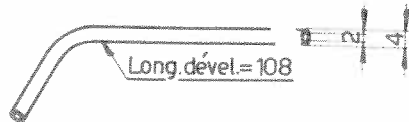

Tube 102VM-705

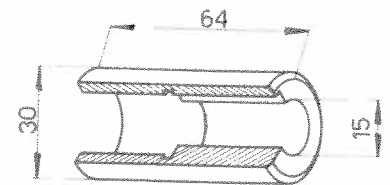

Outil 102VM-799

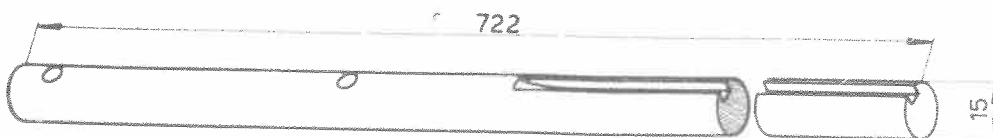

Barre 102VM-801

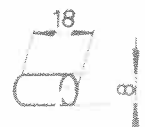

Pivot 102VM-186

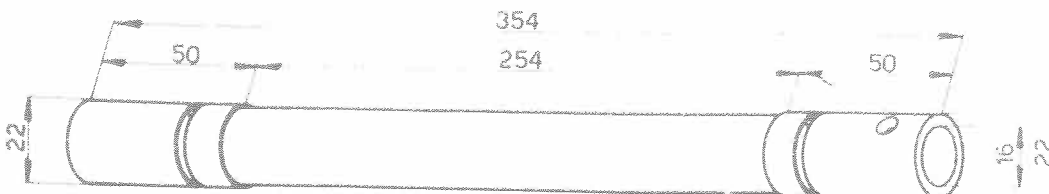

Broche 102VM-800

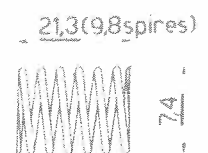

Resort 0074-149



# TOUR 102VM

# TABLIER-CHARIOT

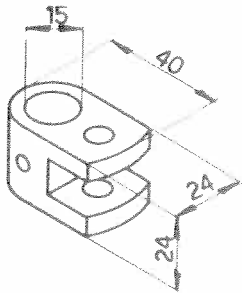

Fourche 102VM-804

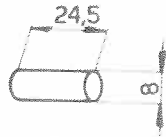

Tige 102VM-805

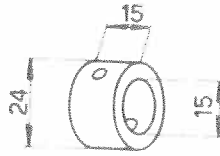

Bague 102VM-803

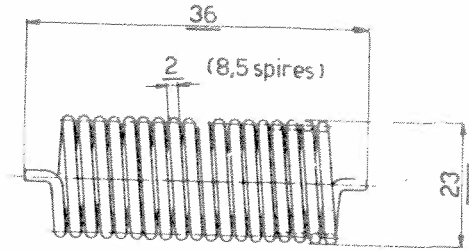

Ressort T230-3

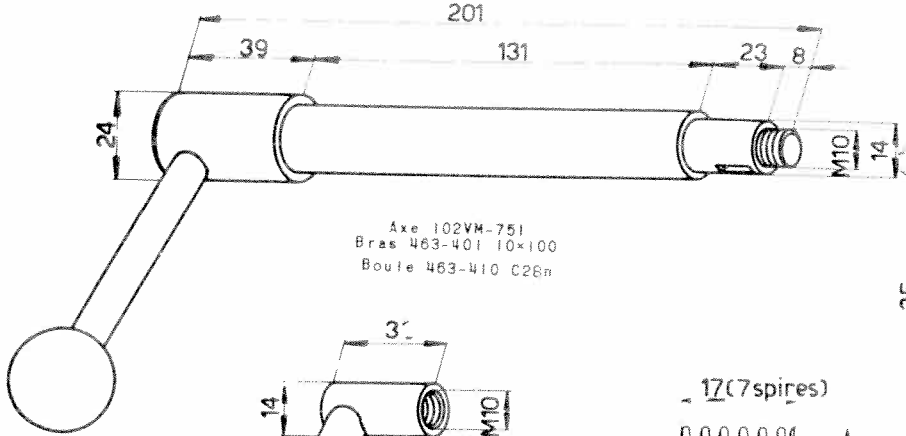

Axe 102VM-751  
Bras 463-401 10x100  
Boule 463-410 C26n

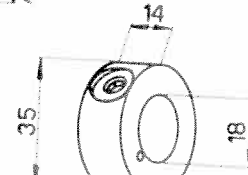

Bague 102VM-754

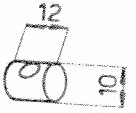

Plot 102VM-750

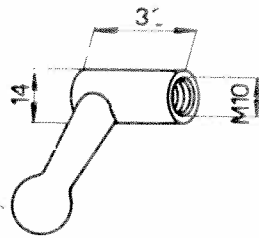

Poulet 102VM-745  
Poignée 102VM-837

12(7 spires)

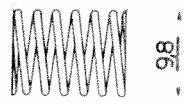

Ressort D096-157

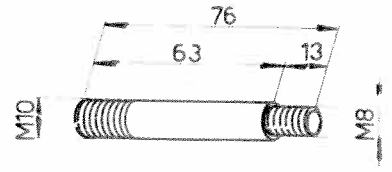

Goujon 102VM-834

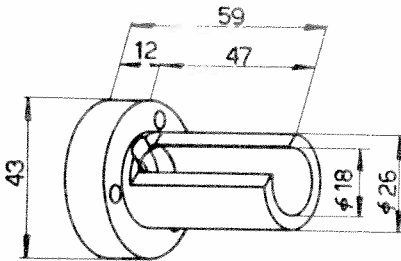

Douille 102VM-839

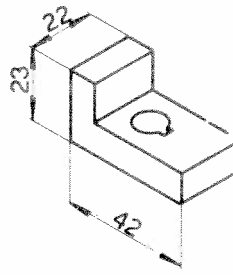

Bride 102VM-831

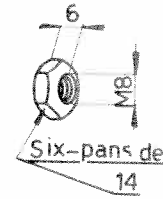

Six-pans de 14  
Rostule 102VM-835

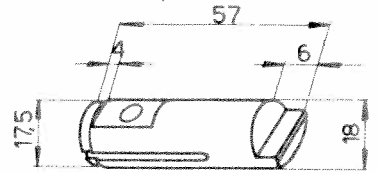

Verrou 102VM-840

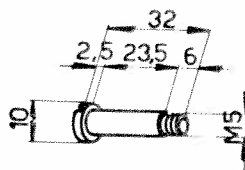

Pivot 102VM-841

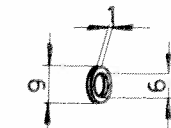

Entretoise 102VM-842

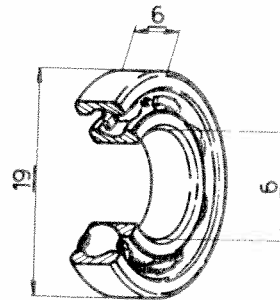

Roulement à billes SKF EL6

25(9,5 spires)

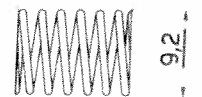

Ressort D092-155

24,5(8,2 spires)

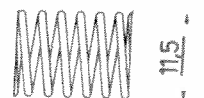

Ressort D115-150

25(10,5 spires)

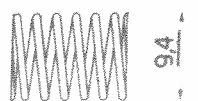

Ressort D094-154

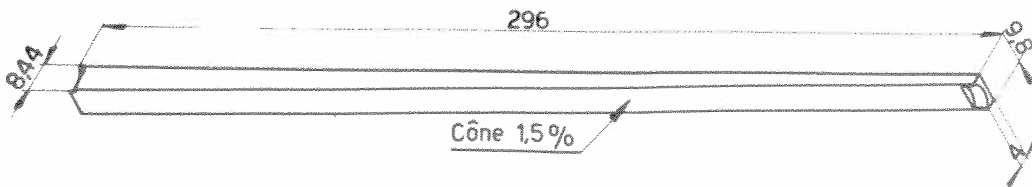

Lardon 102VM-742

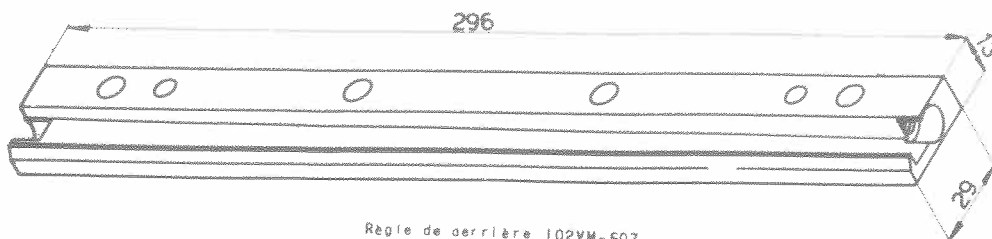

Règle de derrière 102VM-807

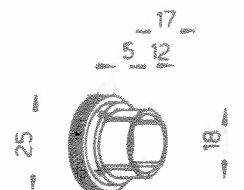

Couvercle 102VM-150

# TOUR 102VM TABLIER-CHARIOT

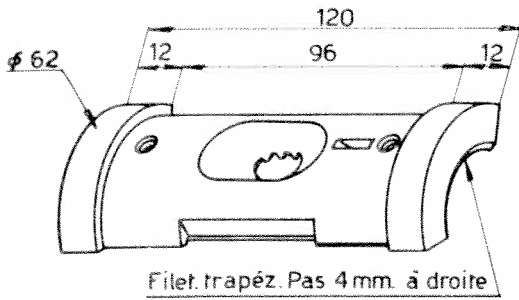

Filet. trapéz. Pas 4 mm. à droite

Peigne 102VM-704

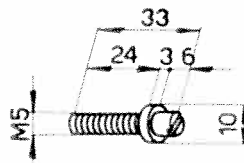

Vis 11A-504

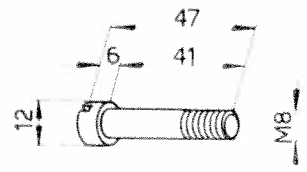

Vis-garde 102VM-705

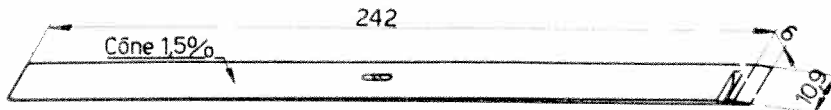

Lardon inférieur 102VM-789

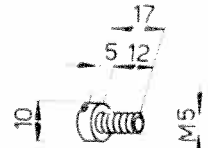

Vis 102VM-743

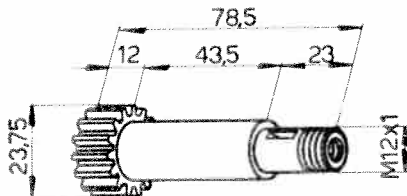

Pignon 102VM-728

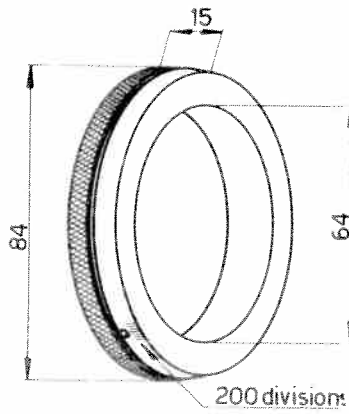

Vernier 102VM-733

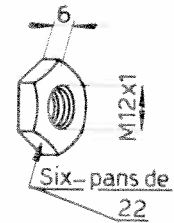

Contre-écrou spécial 102VM-736

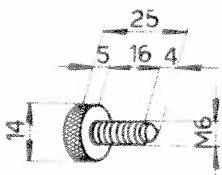

Vis 102VM-737

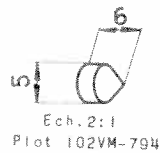

Ech. 2:1  
Plot 102VM-794

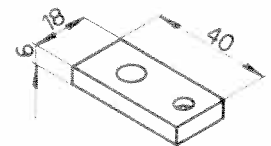

Plaque pour blocage 102VM-790

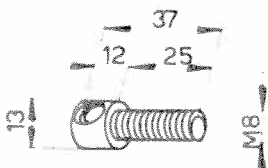

Vis de blocage 102VM-791

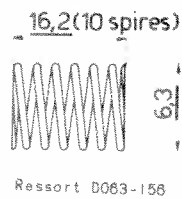

Ressort D083-158

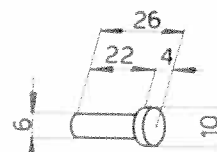

Piston 102VM-732

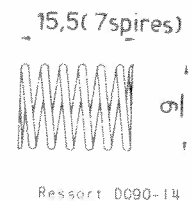

Ressort D090-14

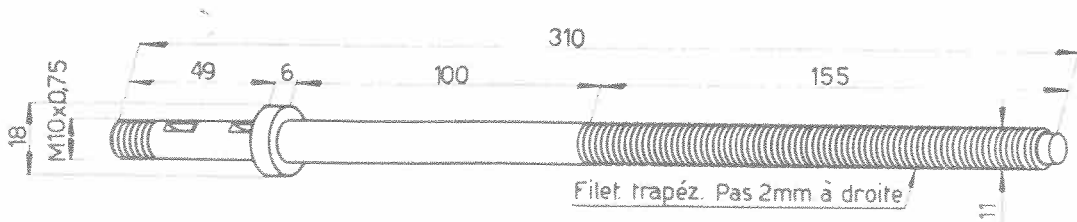

Vis 102VM-725

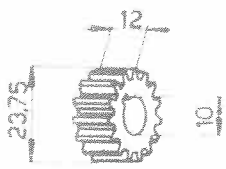

Engrenage 102VM-726

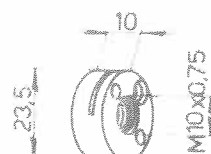

Ecrin 102VM-730

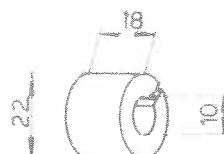

Bague 102VM-729

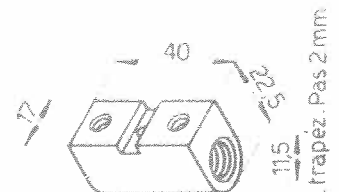

Ecrin inférieur 102VM-727

Filet. trapéz. Pas 2 mm

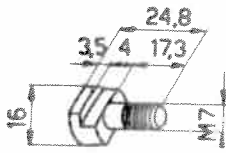

Vis de fixation 102-611-L

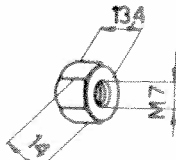

Ecrou 102-611-M

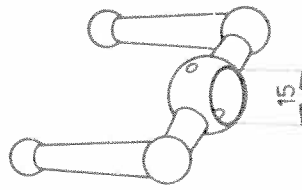

Roulement 102VM-836  
Pos: Les 463-402 6x10x45

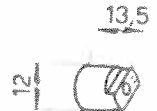

Doigt 102VM-815

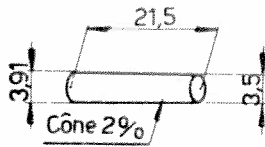

Goupille conique 102-CH-192  
Ech: 2:1

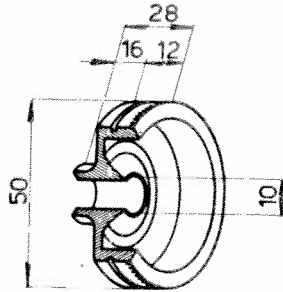

Vernier 102-CH-193



Rondelle élastique 102-CH-172

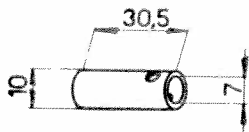

Douille 102-CH-187

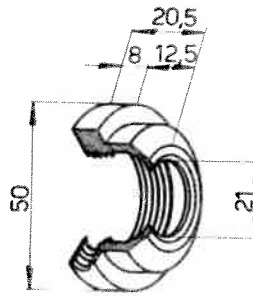

Ecrou 102-CH-189

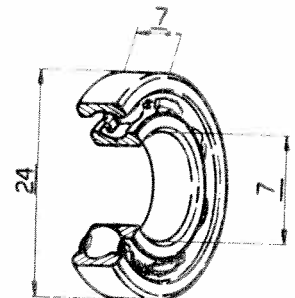

Roulement à billes 102-CH-170

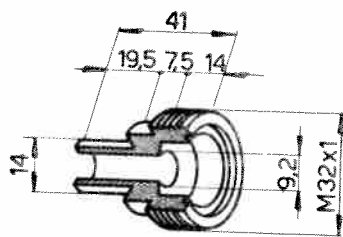

Manchon 102-CH-188

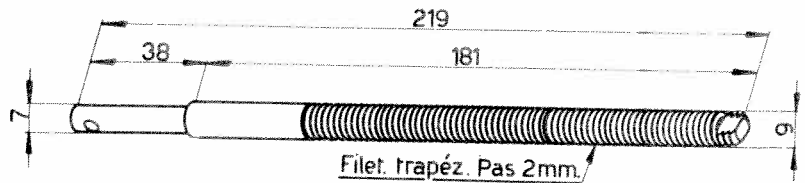

Vis supérieure 102VM-191

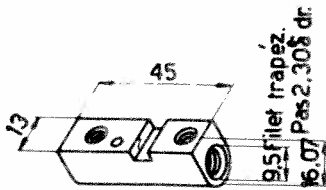

Ecrou supérieur 102-CH-133

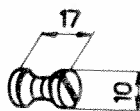

Excentrique 102-613-Z

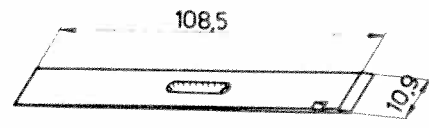

Lardon supérieur 102-611-SG

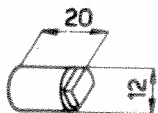

Pivot 102-CH-125

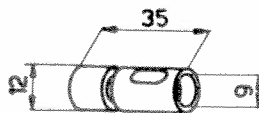

Guide 102-CH-181

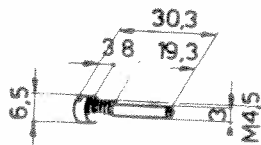

Vis 102-611-Q

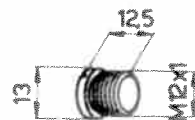

Vis-bouchon 102-614-J

# TOUR 102VM - CONTRE-POUPEE ART. N°277

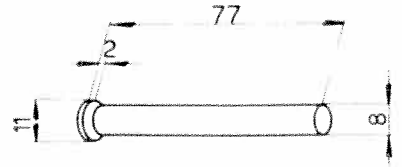

Chasse-pointe 102-608-G

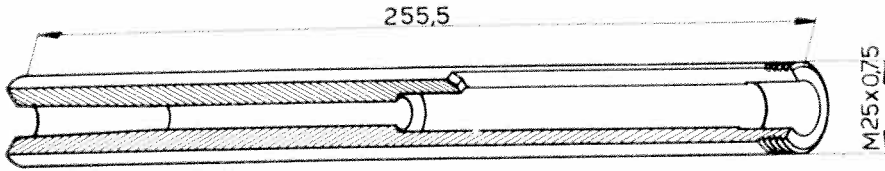

Douille graduée 102-608-D

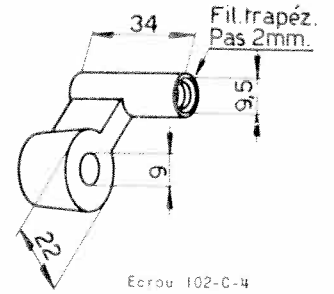

Ecrou 102-C-4

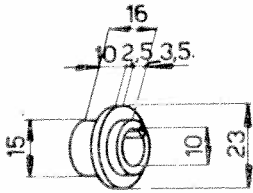

Douille 102-608-P

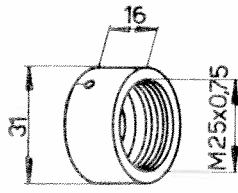

Ecrou-repère 102-608-Y

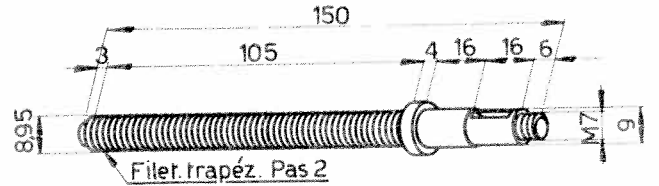

Vis 102-C-3

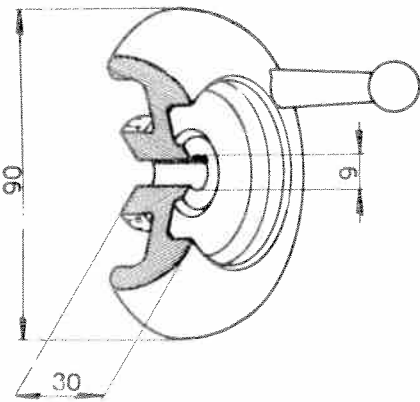

Volant 102VM-353  
Poignée 463-402 8x14x55

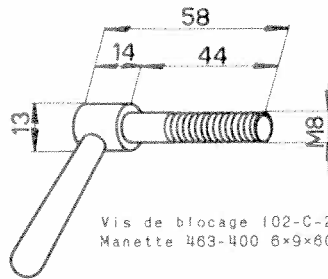

Vis de blocage 102-C-2  
Manette 463-400 6x9x60

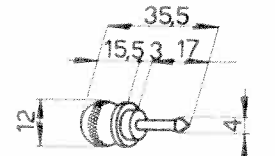

Tige pour huile 102-608-V

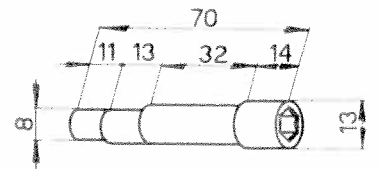

Excentrique 102VM-356

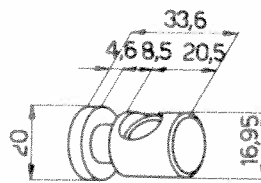

Tirant 102-605-S1

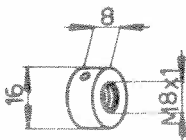

Ecrou 102VM-358

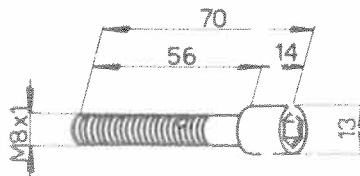

Vis 102VM-357

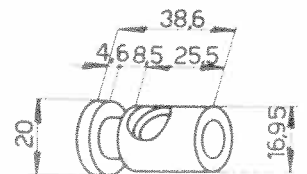

Tirant 102VM-354

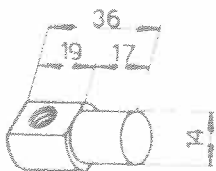

Ecrou 102VM-359

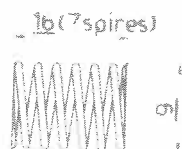

Ressort 0090 55

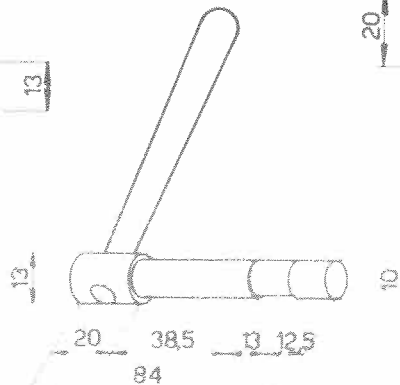

Excentrique 102-608-J  
Manette 463-400 7x10x60

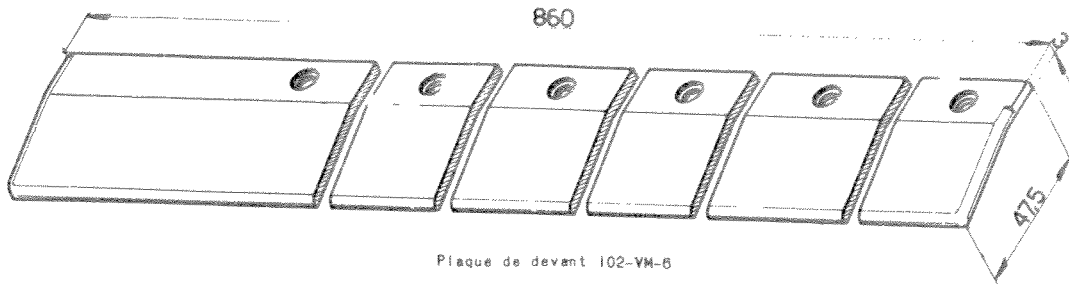

Plaque de devant 102-VM-6

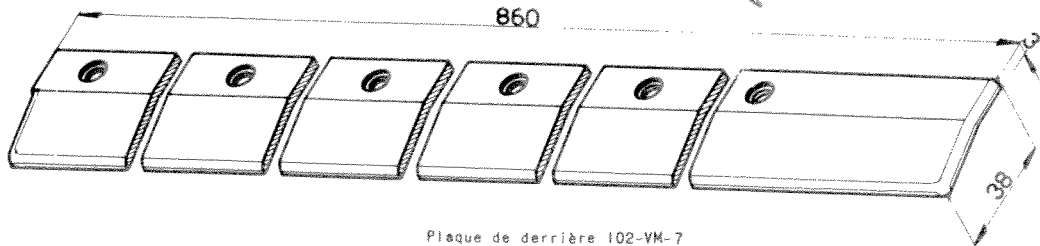

Plaque de derrière 102-VM-7

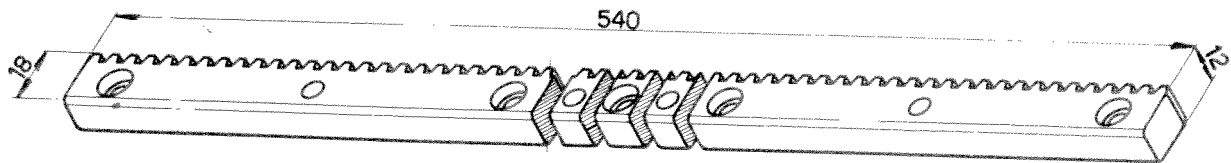

Crémaillère 102-VM-8

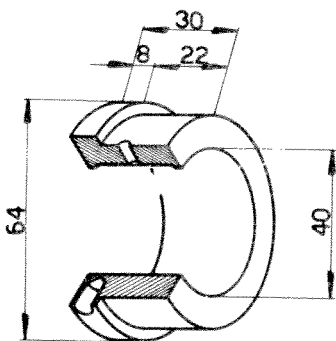

Douille 102-VM-226

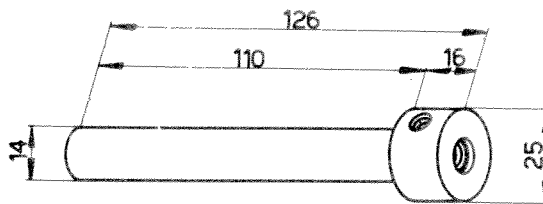

Bouée 102-VM-22

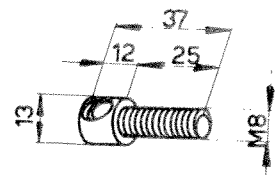

Vis de blocage 102-VM-791

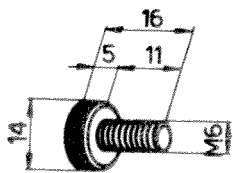

Vis E M6x11 462-275

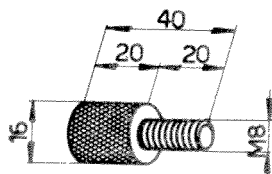

Vis de réglage 102-VM-24

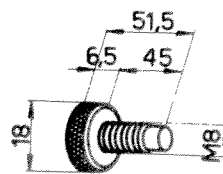

Vis E2 M8x45 462-277

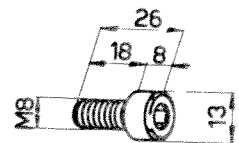

Vis CCM M8x18 462-270

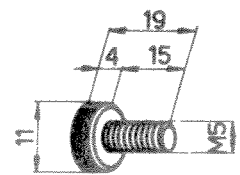

Vis E M5x15 462-274

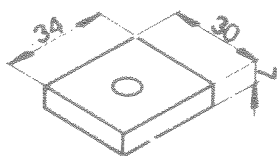

Plaque 102-VM-25

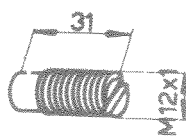

Vis de fixation 102-VM-688

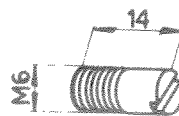

Ech. 2:1  
Vis 15-461

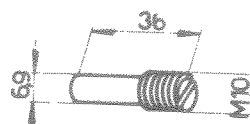

Vis 102-VM-687

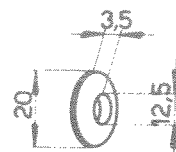

Rotule 102-60, F

# TOUR 102VM

# COMMANDE INDIVIDUELLE

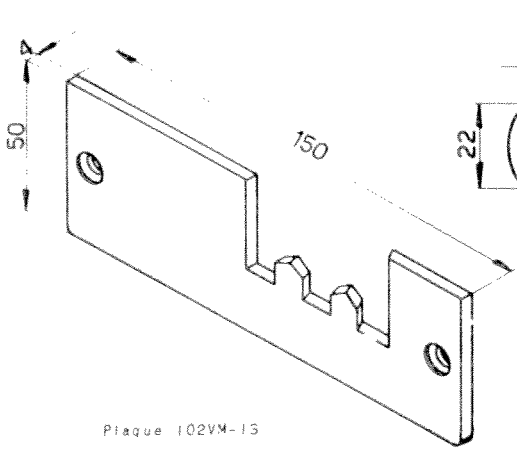

Plaque 102VM-15

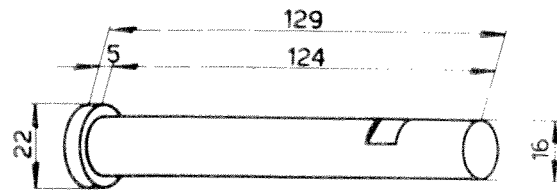

Pivot 120-TS-19

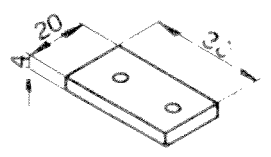

Arrêt 120-TS-100

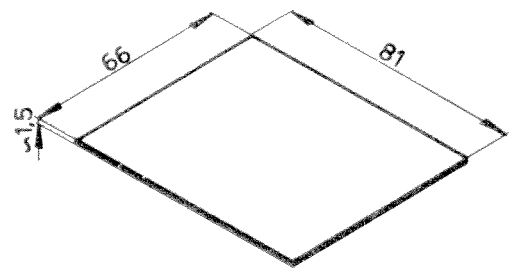

Lame 120-TS-10

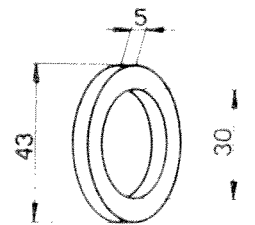

Rondelle feutre SKF Fi 7

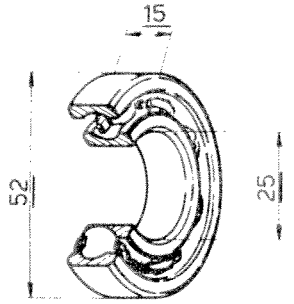

Roulement à billes SKF 6205

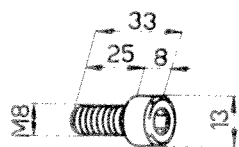

Vis CCM M8x25 462-270

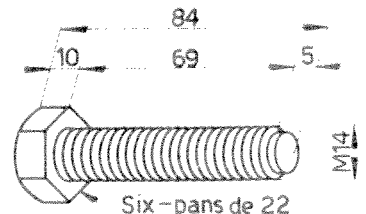

Six-pans de 22

Bouton 120-TS-42

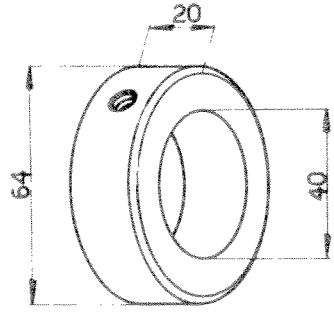

Bague 120-TS-32

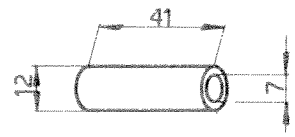

Tube 120-TS-96

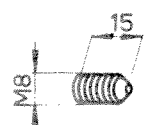

Vis DCMC M8x15 462-217

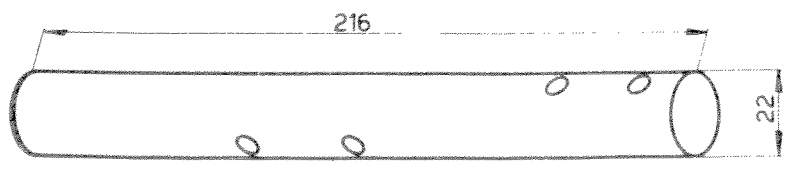

Axe 120-TS-54

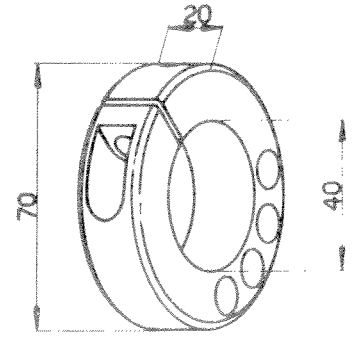

Bague 120-TS-44

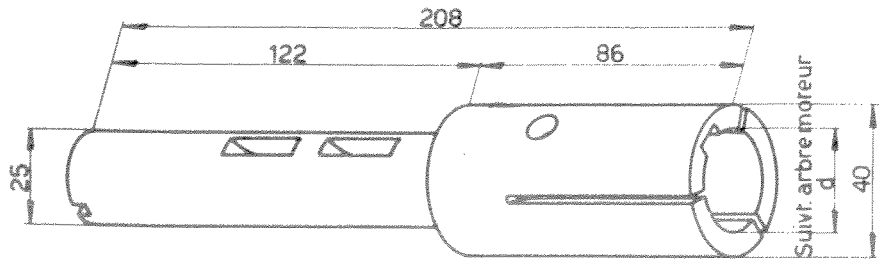

Arbre 120-TS-38

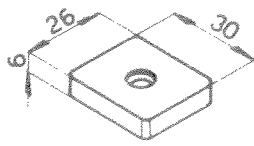

Tampon 120-TS-63

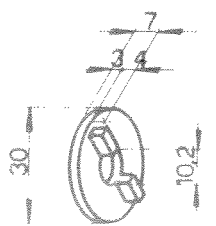

Arrêt 120-TS-100



Axe 120-TS-14



Vis DCMC M6x62 462-217

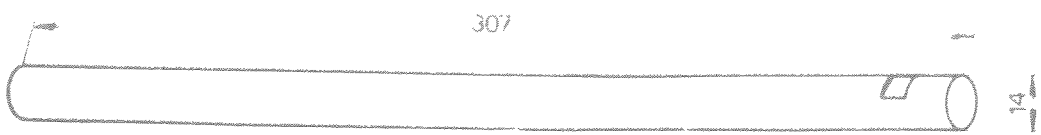

Axe 120-TS-15



Rondelle 120-TS-100

# TOUR 102VM BOITE DE VITESSES

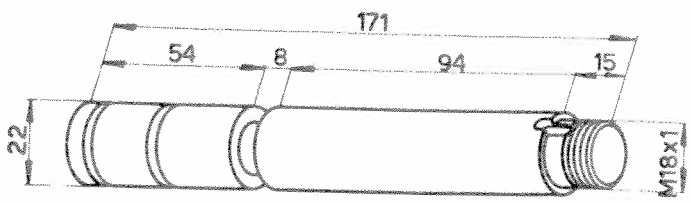

Arbre 102VM-6040

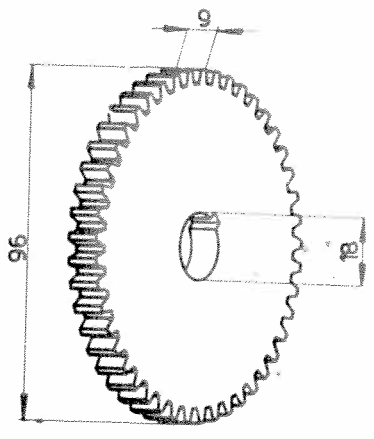

Roue dentée 102VM-6041

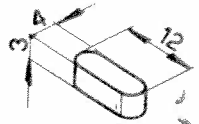

Ech. 2:1  
Clavette 102VM-6043

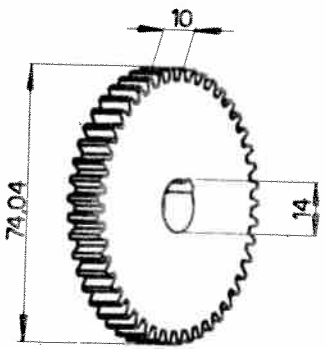

Roue dentée 102VM-6081

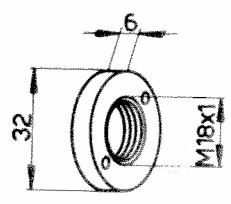

Ecrou 102VM-6042

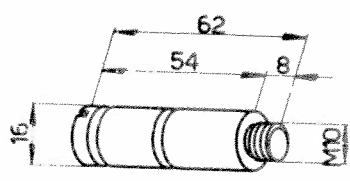

Guide 102VM-6044

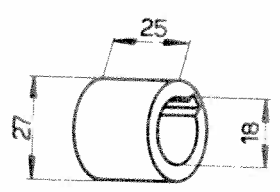

Bague 102VM-1717

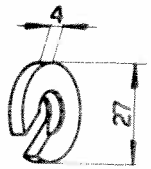

Rondelle à fourche 102VM-1709

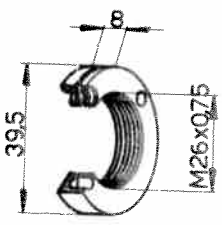

Ecrou 102VM-6113

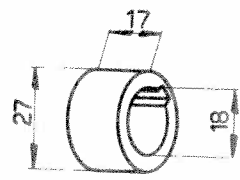

Bague 102VM-1716

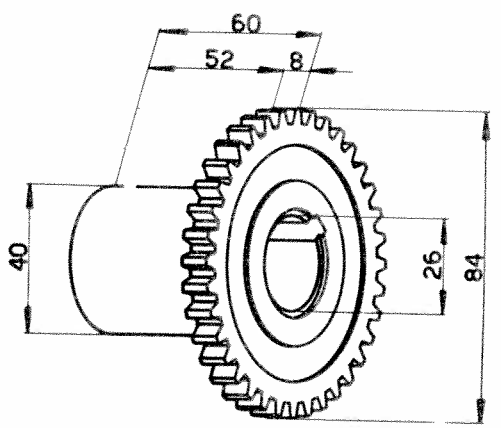

Engrenage 102VM-6031

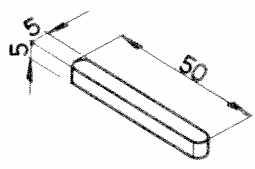

Clavette 102VM-6093

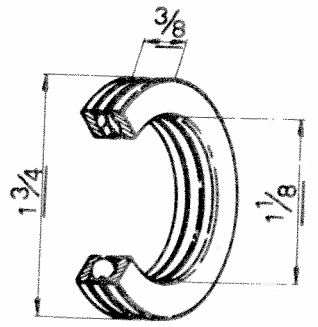

Butée Hoffmann N° EW 1/8

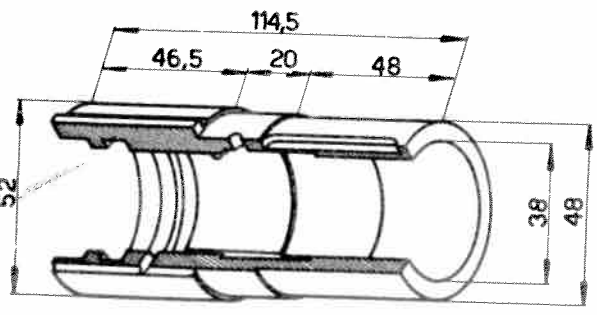

Douille 102VM-6033

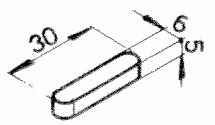

Clavette 102VM-6066

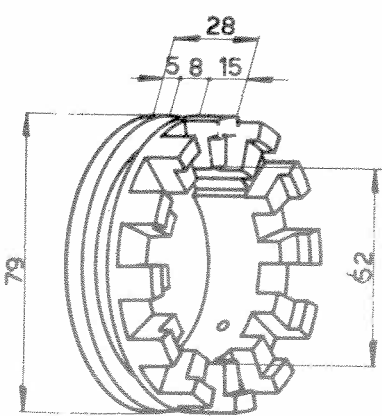

Entraîneur 102VM-6032

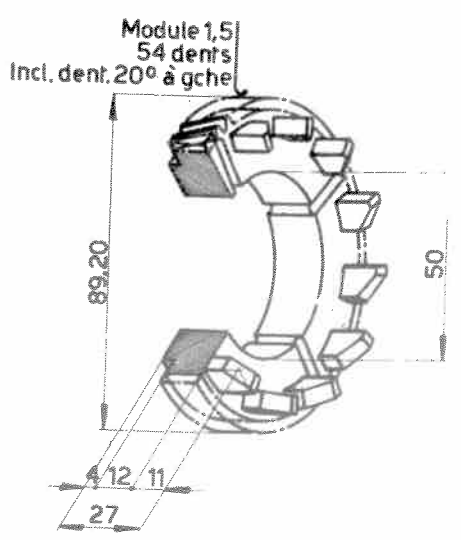

Roue hélicoïdale 102VM-6035

# TOUR 102VM BOITE DE VITESSES

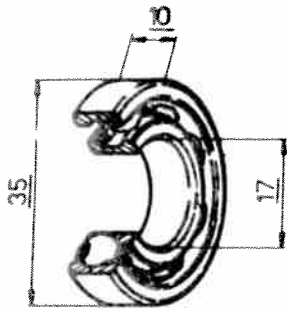

Roulement à billes SKF 6003X

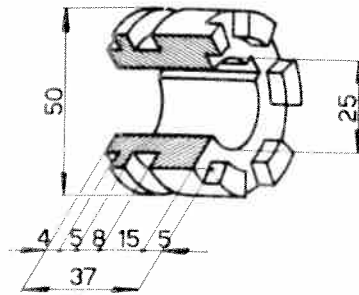

Entraineur 102VM-6057

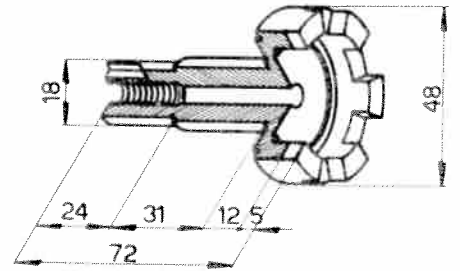

Arbre porte-engrenage 102VM-6147

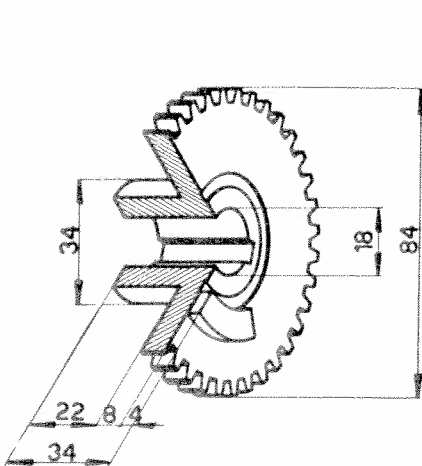

Roue dentée 102VM-6062

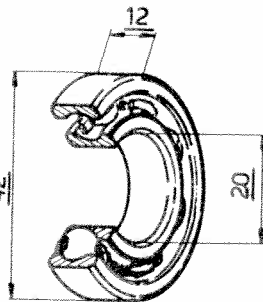

Roulement à billes SKF 6004X

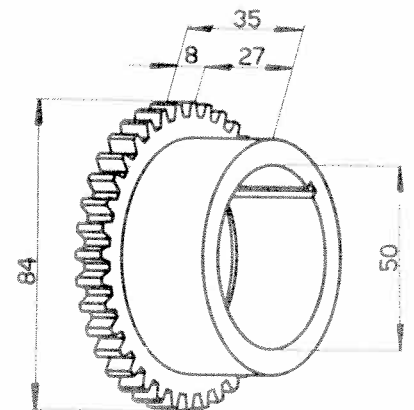

Engrenage 102VM-6058

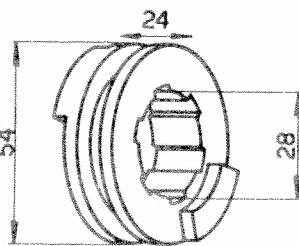

Entraineur 102VM-6152

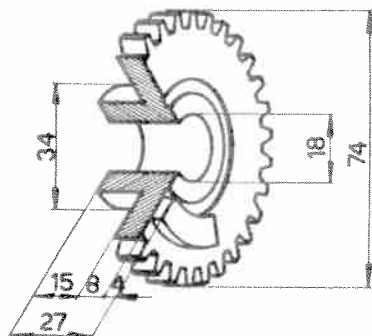

Roue dentée 102VM-6063

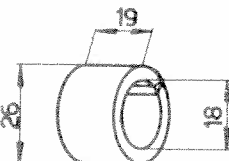

Boite 102VM-6061

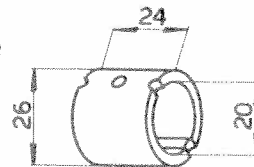

Emboilage 102VM-6114

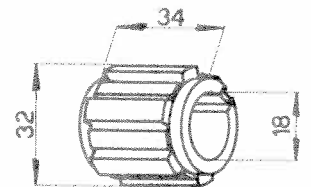

Manchon 102VM-6151

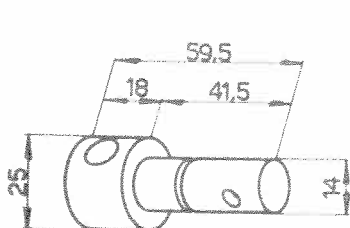

Pivot 102VM-6071

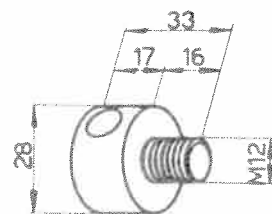

Vis de blocage 102VM-6047

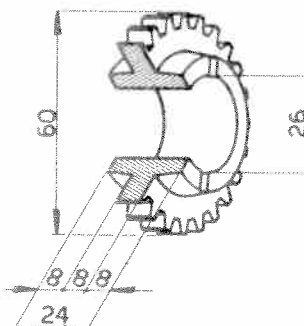

Roue intermédiaire 102VM-6065

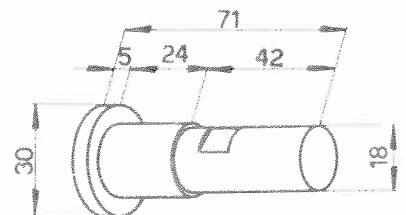

Tourillon 102VM-6064

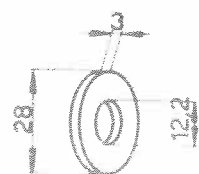

Bague 102VM-6115

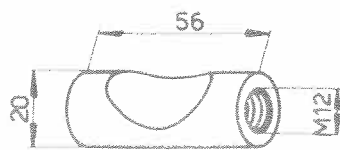

Fige de serrage 102VM-6066

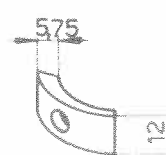

Segment 102VM-6080

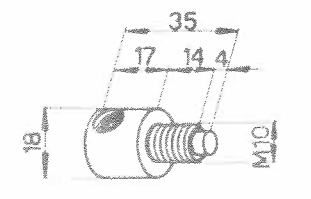

Arbre 102VM-6113



Clavette 102VM-6078

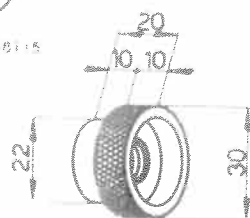

Poullet 102VM-6079

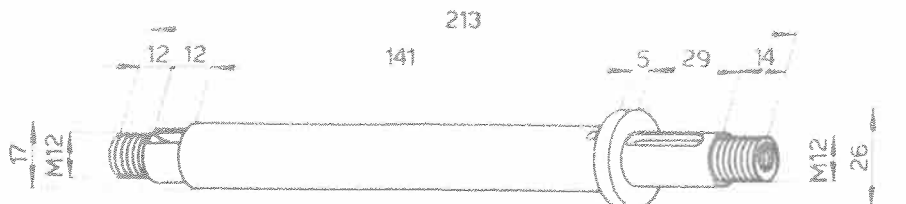

Arbre 102VM-6086



# TOUR 102VM BOITE DE VITESSES

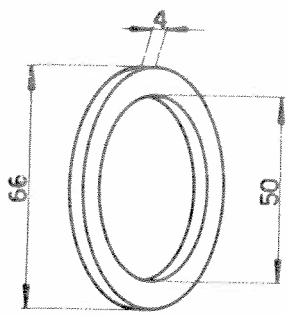

Bague de frottement 102VM-6034

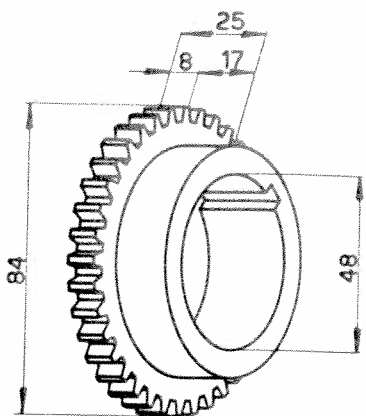

Roue dentée 102VM-6036

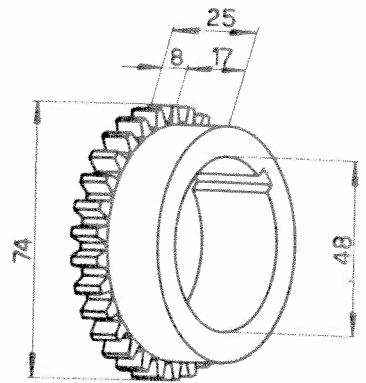

Roue dentée 102VM-6096

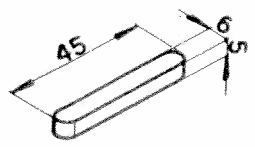

Clavette 102VM-6098

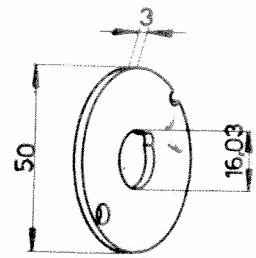

Bague 102VM-6116

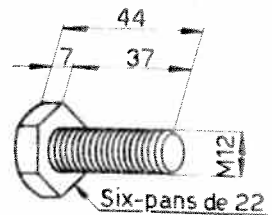

Six-pans de 22

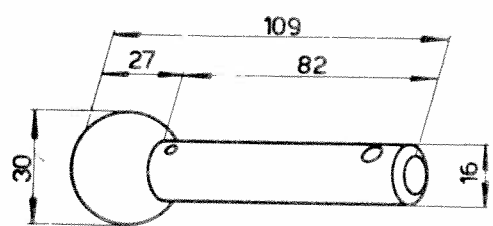

Rotule 102VM-684

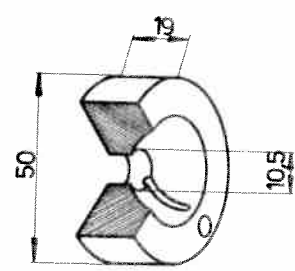

Bague à rotule 102VM-685

Vis 102VM-6094

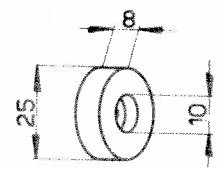

Rondelle 102VM-686

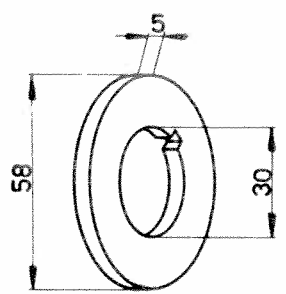

Bague 102VM-6037

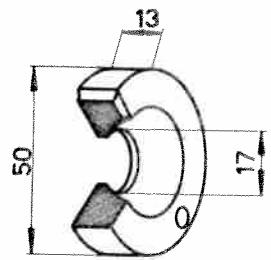

Bague à rotule 102VM-683

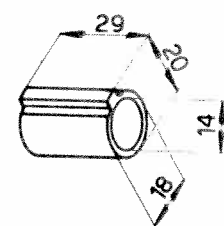

Douille à ergot 102VM-1713

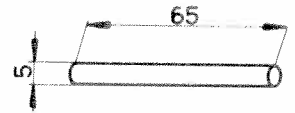

Tige cyl. 102VM-689

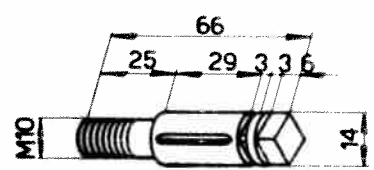

Tourillon 102VM-1712

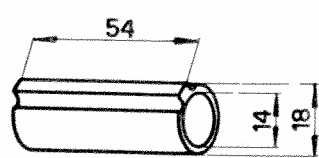

Douille à ergot 102VM-1721



Rondelle à fourche 102VM-1715

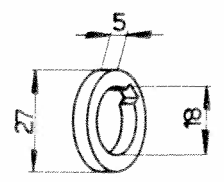

Bague intermédiaire 102VM-1714

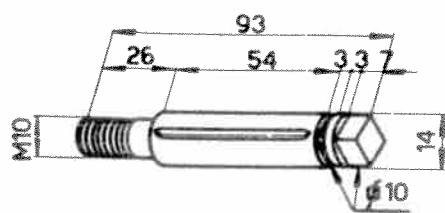

Tourillon 102VM-1720

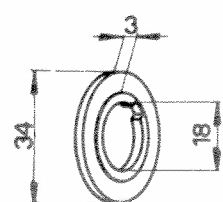

Rondelle 102VM-6148

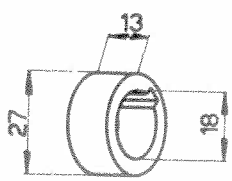

Bague 102VM-1723

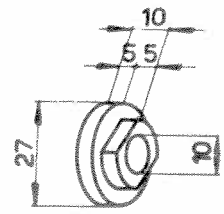

Rondelle à portée 102VM-1711

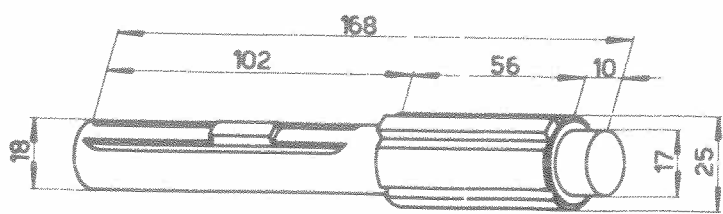

Arbre 102VM-6150

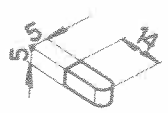

Clavette 102VM-6133

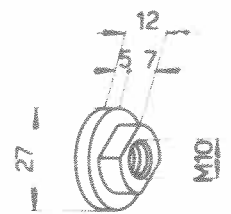

Ecrou 102VM-1710

# TOUR 102VM BOITE DE VITESSES

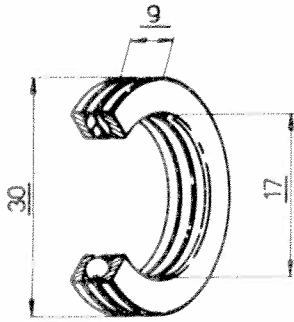

Butée à billes SKF 51103

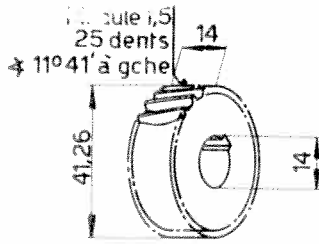

Roue hélicoïdale 102VM-6067

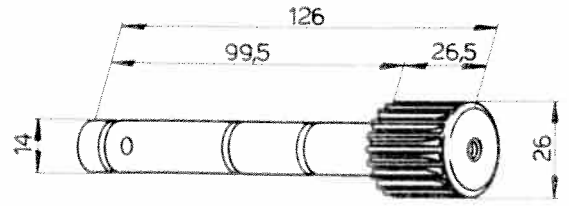

Pignon 102VM-6069

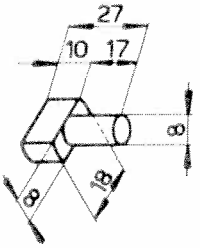

Doigt 102VM-6070

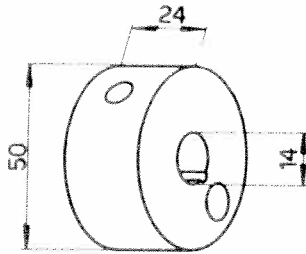

Canon 102VM-6072

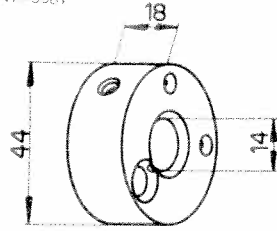

Disque 102VM-6073



Piston 102VM-6075

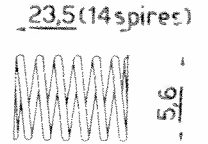

Ressort D058-38

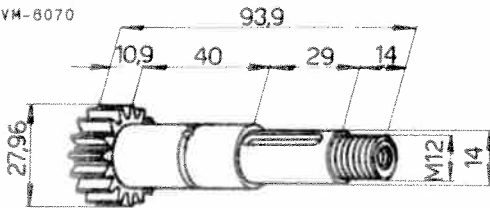

Pignon 102VM-6077

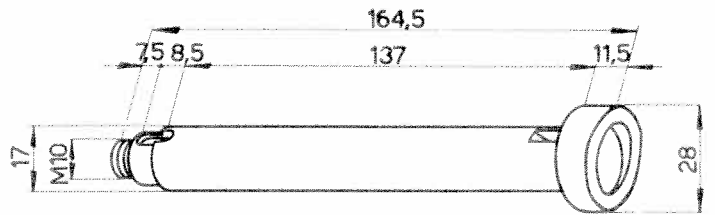

Axe 102VM-6155

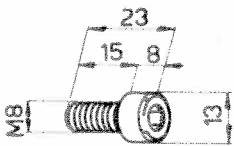

Vis OCM M8x15 162-270

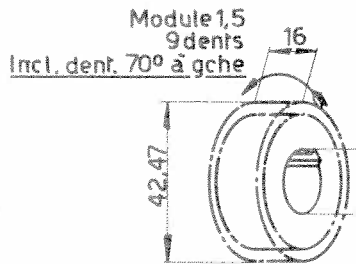

Roue hélicoïdale 102VM-6082

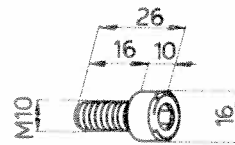

Vis OCM M10x16 162-270

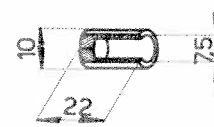

Piston 102VM-6142

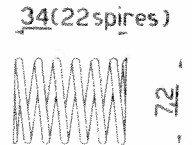

Ressort D072-96

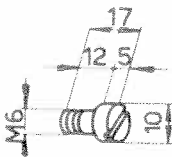

Vis de fixation 102VM-8085



Levier 102VM-6048  
Boule 463-410 C22n

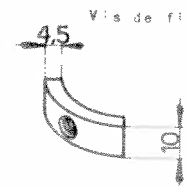

Segment 102VM-6084

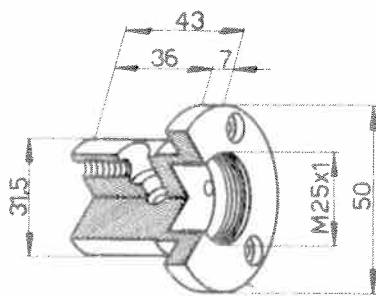

Corps de pompe 102VM-6157



Douille 102VM-6156

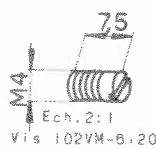

Vis 102VM-6.20

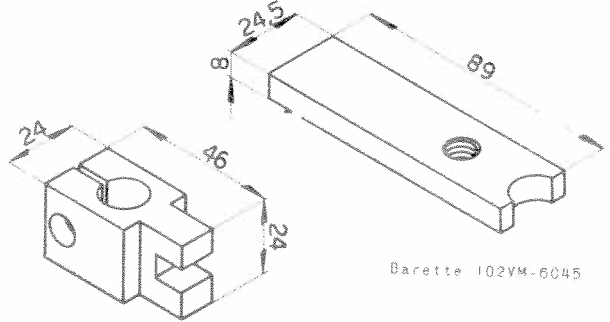

Bride 102VM-6067

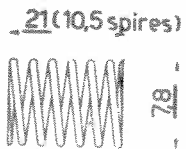

Ressort D078-39

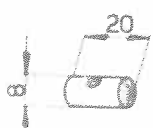

Piston 102VM-6117

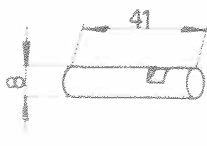

Piston 102VM-6117

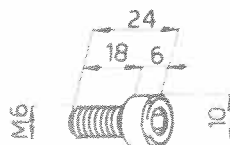

Vis OCM M6x16 162-270

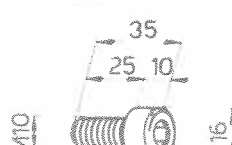

Vis OCM M10x16 162-270

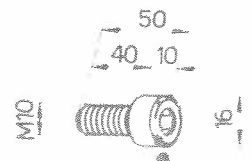

Vis OCM M8x16 162-270

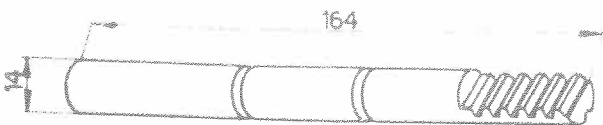

Triangle 102VM-6068

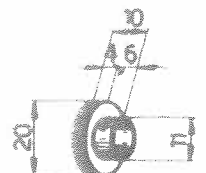

Couvercle graisseur 65-8-50



Piston 102VM-6118

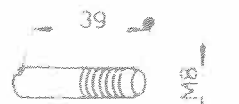

Vis de fixation 102VM-8117

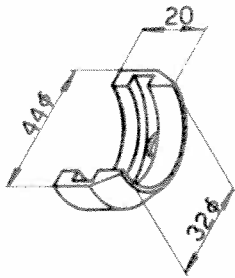

Chicane 102VM-6178

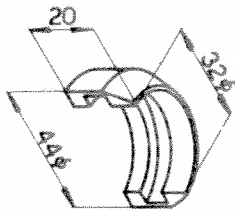

Chicane 102VM-6179

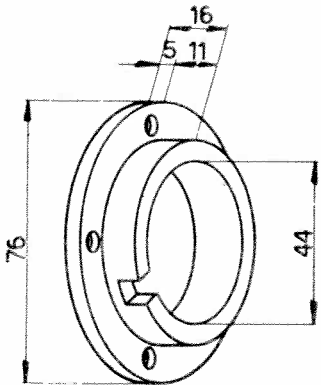

Bague 102VM-6180

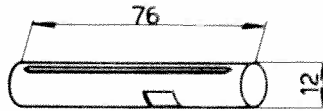

Pivot 102VM-256

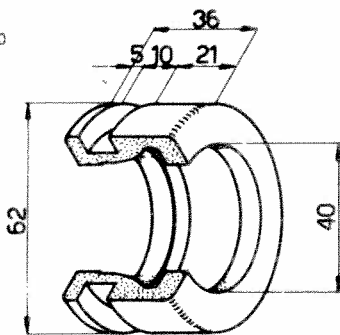

Bobine 102-616-V2

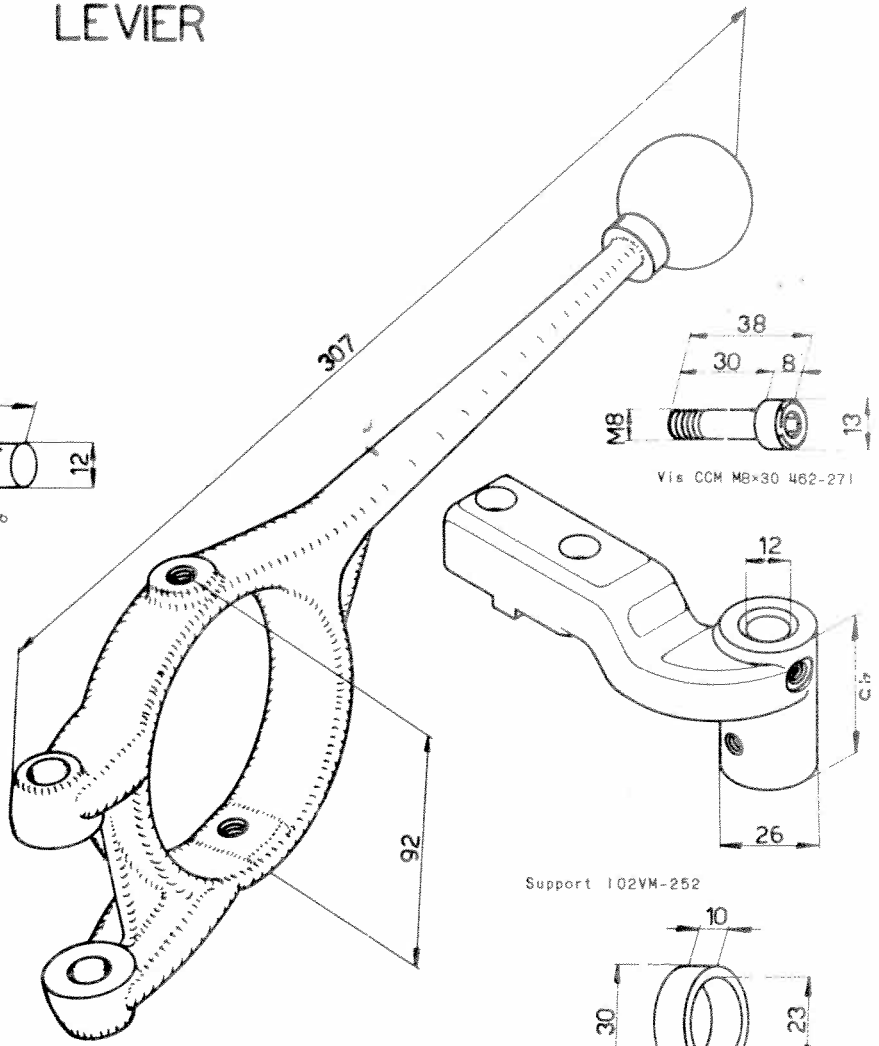

Levier 102-616-Q avec boule 463-410 C36n

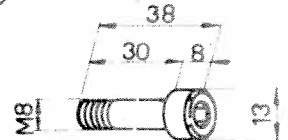

Vis CCM MBx30 462-271

Support 102VM-252

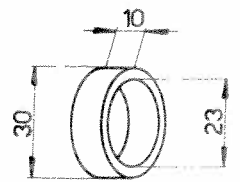

Bague 102VM-255

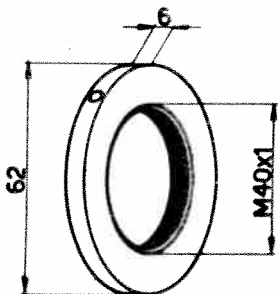

Bague 102VM-258

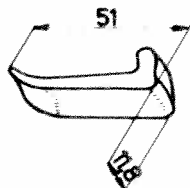

Chien 120-P-109

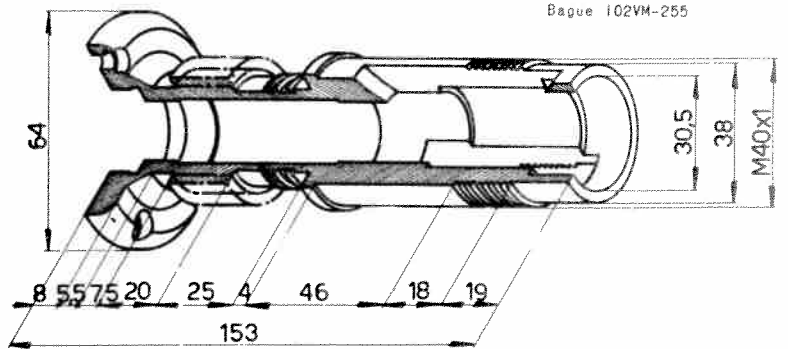

Manchon 102VM-253

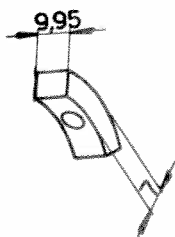

Segment 102VM-259

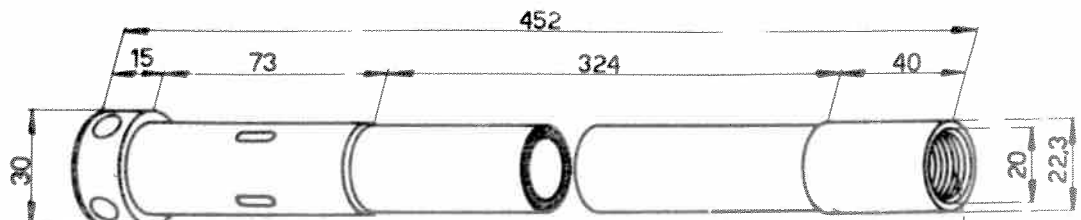

Fil.dents de scie. Pas 6 filets sur 10mm=1,666

Clé de serrage 102VM-254

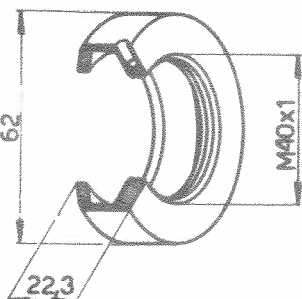

Bague 102VM-257

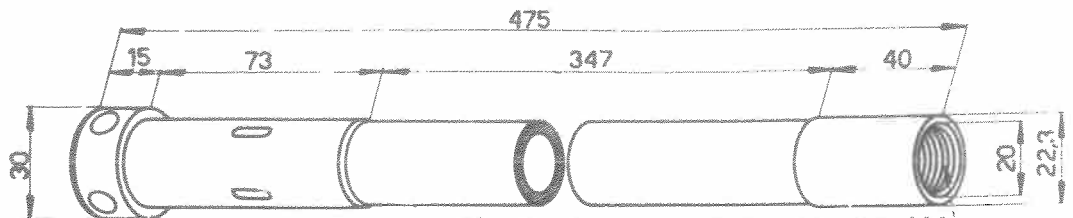

Fil.dents de scie. Pas 6 filets sur 10mm=1,666

Clé de serrage 102VM-260

# TOUR 102VM

## SUPPORT A MAIN LUNETTE A 3 CHIENS LUNETTE A SUIVRE

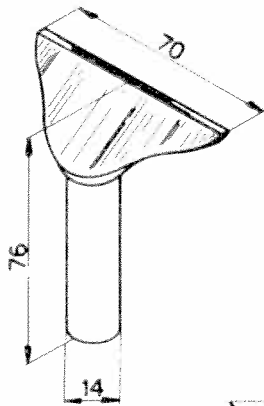

Eventail 102-615-B

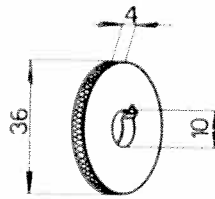

Rondelle 102VM-1303

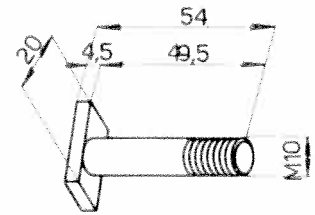

Tige de blocage 102-VM-1392

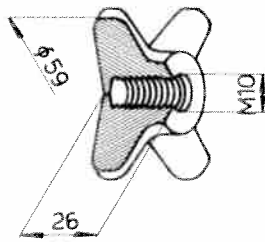

Poulet 102VM-1301

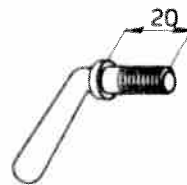

Manette de blocage 102-615-C

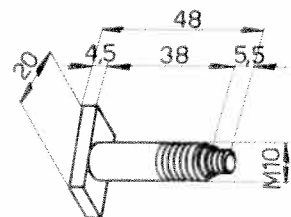

Tige de fixation 102VM-1602

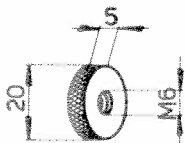

Poulet 102VM-1603

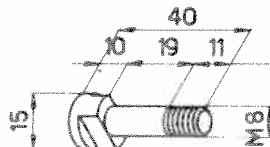

Vis de fixation 102-618-C

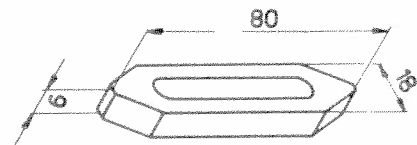

Chien 102-618-B

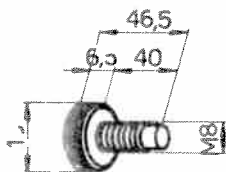

Vis E2 M8x40 462-277

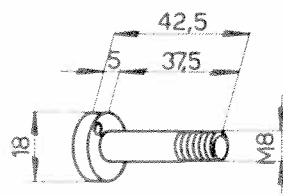

Tige de fixation 102VM-1655

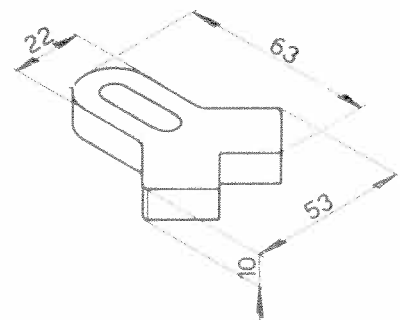

Chien 102VM-1652

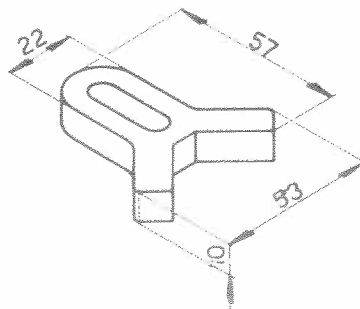

Chien 102VM-1653

# TOUR 102VM

# POMPE ET TUYAUTERIE. GENOUILLERE

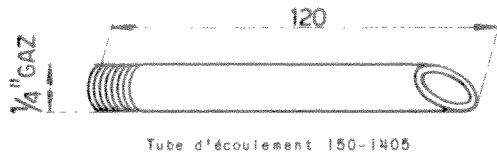

Tube d'écoulement 150-1405

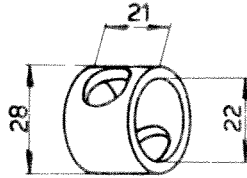

Douille 51-7025

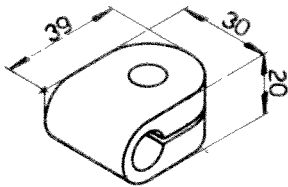

Bride 150-1401

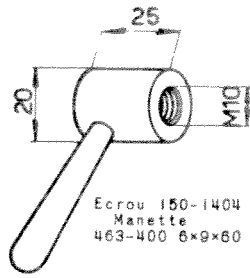

Ecrou 150-1404  
Manette  
463-400 6x9x60

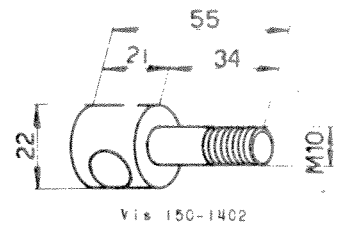

Vis 150-1402



Tringle 150-1410

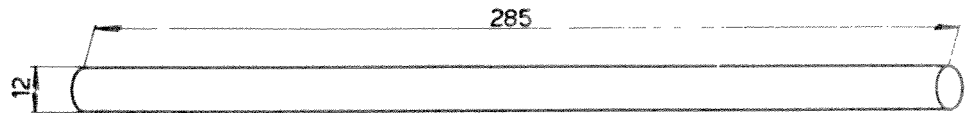

Tringle 130-2663

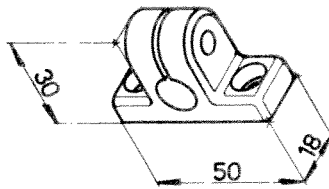

Support 120-VM-1383

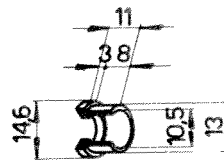

Douille 51-7013

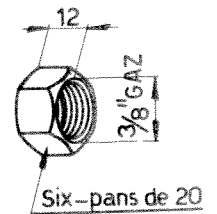

Six-pans de 20  
Ecrou 52-773

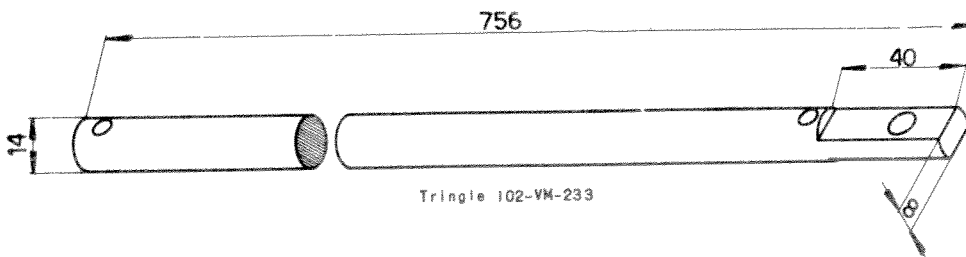

Tringle 102-VM-233

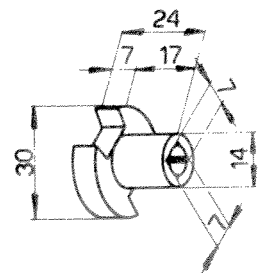

Entraîneur 102-G-2

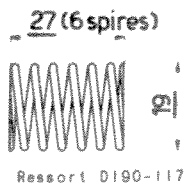

Ressort D190-117