

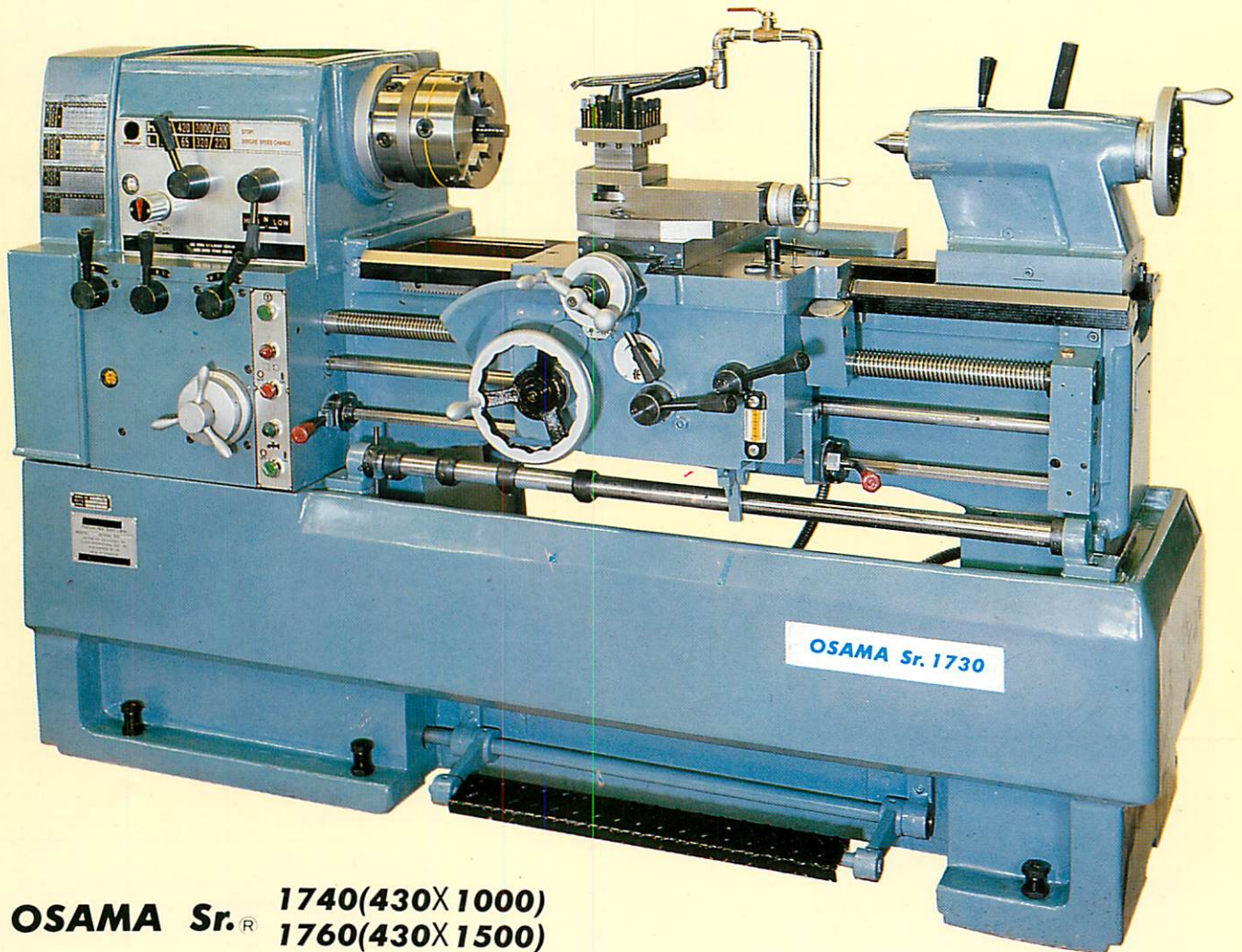

OSAMA Sr.®

PRECISION HIGH SPEED LATHE



OSAMA Sr.® 1740(430X1000)
1760(430X1500)

MAJOR FEATURES:

1. Made of high tensile cast iron and solidly built, processed by high-frequency heat treatment as well as precision grinding, the machine bed is large and tall.
2. Main gears, heat-treated and ground by tooth type grinder, are made of special abrasion and shock-proof alloy steel.
3. Large in diameter, the spindle bore, furnished with taper roller cylindrical bearings, may serve the purpose of powerful and precision cuttings.
4. Perfect design in gear change, the gear box may perform extensively and directly the threading in British or metric system.
5. Oil dipping gear box and shield bed as well as sliding surface are of lubrication in full automation.
6. Power sources are cut off synchronously and directly when the pedal brake is stepped on. It is truly safe and reliable.
7. Totally adopted with magnetic contactor and overloading protective device in electric layout, the motor is highly safe and free from accidental burt-out.
8. The fourth cross bar is designated for positioning of cuttings in any length.
9. 52mm in spindle bore diameter, it is suitable for processing of arbor in large diameter.
10. This company readily supplies the domestic and overseas customers with quality products.

PONCHO ENTERPRISE CO., LTD.

P.O. BOX 26-282 TAIPEI, TAIWAN. CABLE: "PONCHO" TAIPEI

TEL: 7087425, 7087939

TELEX: 11083 PONCHO

www.umanuals.com

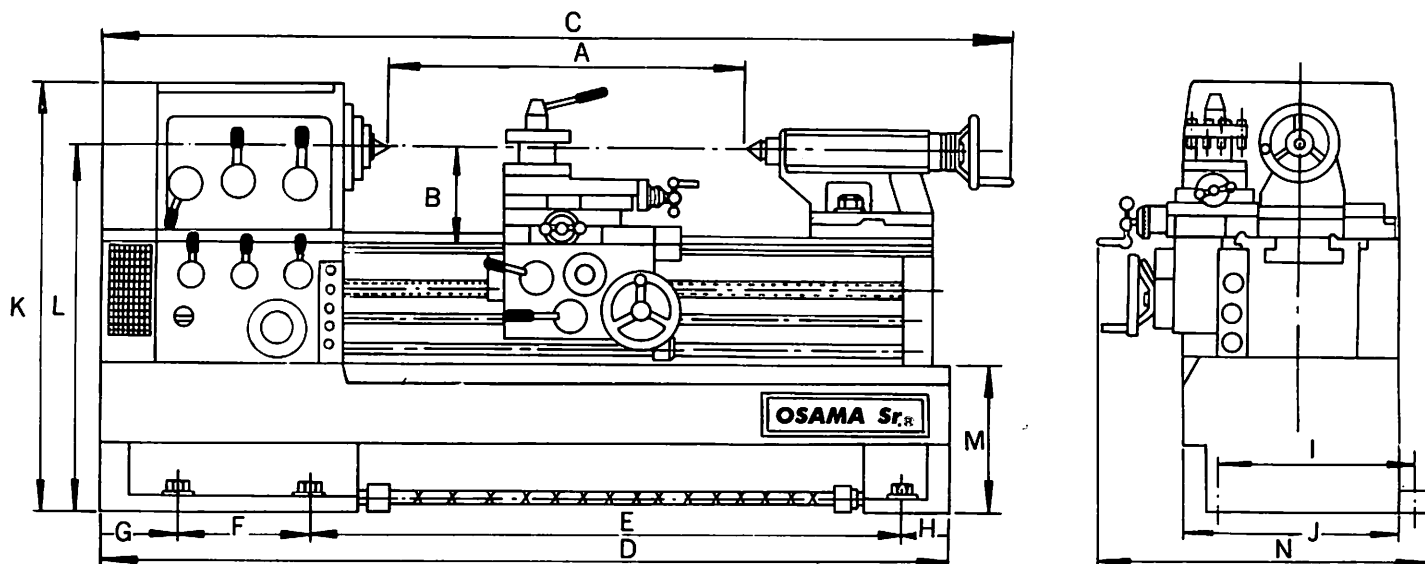

MODEL	A	B	C	D	E	F	G	H	I	J	K	L	M	N
430x750G	750	200	1900	1852	1055	440	195	170	520	550	1172	1060	515	820
430x1000G	1000	200	2150	2102	1305	440	195	170	520	550	1172	1060	515	820

SPECIFICATIONS:

	LATHE	Model 430x750G	Model 430x1000G Model 430x1500G
CAPACITIES	Swing over bed	430mm (17")	
	Swing over cross slide	230mm (9")	
	Swing over gap		609mm (24")
	Distance between center	750mm (30")	1000mm(40")*1500mm(60")
HEADSTOCK	Spindle nose	ASA 1-6 OR D-1-6	
	Hole thru spindle	51mm (2")	
	Taper of spindle hole	MT #6	
	Range of spindle speeds (8 speeds)	65 – 2000rpm	
THREADS AND FEEDS	English threads range	4 – 56	
	Metric threads range	P0.5 – P7	
	Longitudinal feeds range	0.088 – 0.617	
	Cross feeds range	0.032 – 0.222	
	Leadscrew diameter	35mm (1-3/8")	
	Leadscrew pitch	4 TPI	
TAILSTOCK	Center	MT # 4	
	Spindle travel	100mm (4")	
	Spindle dia	58mm (2 1/8")	
MOTOR	Main drive motor	5HP (3.75KW)	
	Coolant pump	1/8HP (0.1 KW)	
MACHINE DIMENSION	Floor space (L x W x H)	1900 x 820 x 1172mm (75 x 32 x 46")	2150 x 820 x 1172mm (86 x 32 x 46") *2675x820x1172mm (107x32x46")
	Net weight	Ca 1650kg	Ca 1850kg *Ca 2200kg
	Gross weight	Ca 1850kg	Ca 2050kg *Ca 2400kg

* Data contained in this catalog is for your information only, designs and specifications are subject to change without advance notice.