

MYFORD
1495 DIVIDING ATTACHMENT

Theory

Since, in order to make the fullest possible use of the attachment, the theory must be thoroughly understood this is dealt with first. As stated on the chart the ratio of the worm wheel to the worm is 60:1. This means that 60 revolutions of the index crank which operates the worm are required for one revolution of the spindle. For four divisions, for example, we should need a quarter of 60, that is, 15 revolutions of the index crank per division.

$$\text{That is } \frac{60}{4} = 15$$

60 is the 'constant' for the attachment.

4 was the number of divisions required.

15 is the number of revolutions of the index crank (i.e. of the worm) required for each division.

To take an example from the chart; suppose that 9 divisions are required.

$$\frac{60}{9} = \frac{20}{3} = 6\frac{2}{3}$$

Referring to the top left hand corner of the chart we see that on the No. 1 plate it is only the circle with 45 holes which is divisible by 3, though on the No. 2 plate 42 is also divisible by 3. Either of these could be used. Considering the former, however, we get

$$\frac{60}{9} = \frac{20}{3} = 6\frac{2}{3} = 6\frac{30}{45}$$

For each division we shall, therefore, require 6 complete revolutions of the index crank plus 30 holes on the 45 hole circle.

It will be obvious that although the chart only goes up to 100 there will be many numbers above this which can be directly obtained from the standard plates.

Consider 124 divisions

$$\frac{60}{124} = \frac{15}{31}$$

The No. 2 plate has a circle having 31 holes so that, using this, we require to advance the index crank 15 holes for each division.

It will be realised that a further range of divisions can be obtained if the user is prepared to make extra plates. Take for example 144 divisions

$$\frac{60}{144} = \frac{5}{12}$$

None of the plates has a circle with 12 holes, nor any number divisible by 12, but a plate having this number could readily be made. It may, however, be considered worthwhile to have 24 holes, since this would enable 288 divisions to be obtained in the event of the latter being required, at a later date.

The sector arms

The two arms of the assembly are secured, one to the other, in any required setting by a slotted screw. The whole assembly which is mounted on the worm shaft bracket is retained in position by friction, so that, whilst it can be readily rotated as the dividing operation progresses, it is firmly held in the individual settings.

Where the movement of the index crank is less than about two thirds of a revolution per division (see example for 124 divisions above) or a whole number of revolutions plus a portion of a revolution less than about two thirds of a revolution (see chart for 25 divisions) the movement of the plunger on the index crank will be between the arms.

Where the arc of movement of the index crank exceeds roughly two thirds of a revolution or a number of full turns plus more than about two thirds of a revolution the plunger will operate 'over' the sector arms (see chart for 16 divisions).

Setting the sector arms

A. Operation between the arms (e.g. 25 divisions).

Mount the No. 1 division plate with the numbered holes to the top. Adjust the setting of the index crank so that the plunger will drop into the holes in the 45-hole circle. Open out the sector arms so that there is about 180° between them. With one arm (call this arm A) to the left of the numbered hole and the other arm (call this arm B) at about '4 o'clock' rotate the crank clockwise until the plunger will drop into the numbered hole. Next, rotate the sector arms clockwise until arm A is touching the left hand side of the plunger and arm B is at about '6 o'clock'. Unless it is already free, slacken the screw which clamps the two arms together.

Starting at the hole to the right of the plunger count 18 holes in a clockwise direction and, holding arm A firmly against the left hand side of the plunger, move arm B anticlockwise until its inner edge lines up with the lower edge of the 18th hole and tighten the screw to lock the sector arms together. (N.B. In this example there should be a total of 19 holes between the sector arms). (Fig. 1)

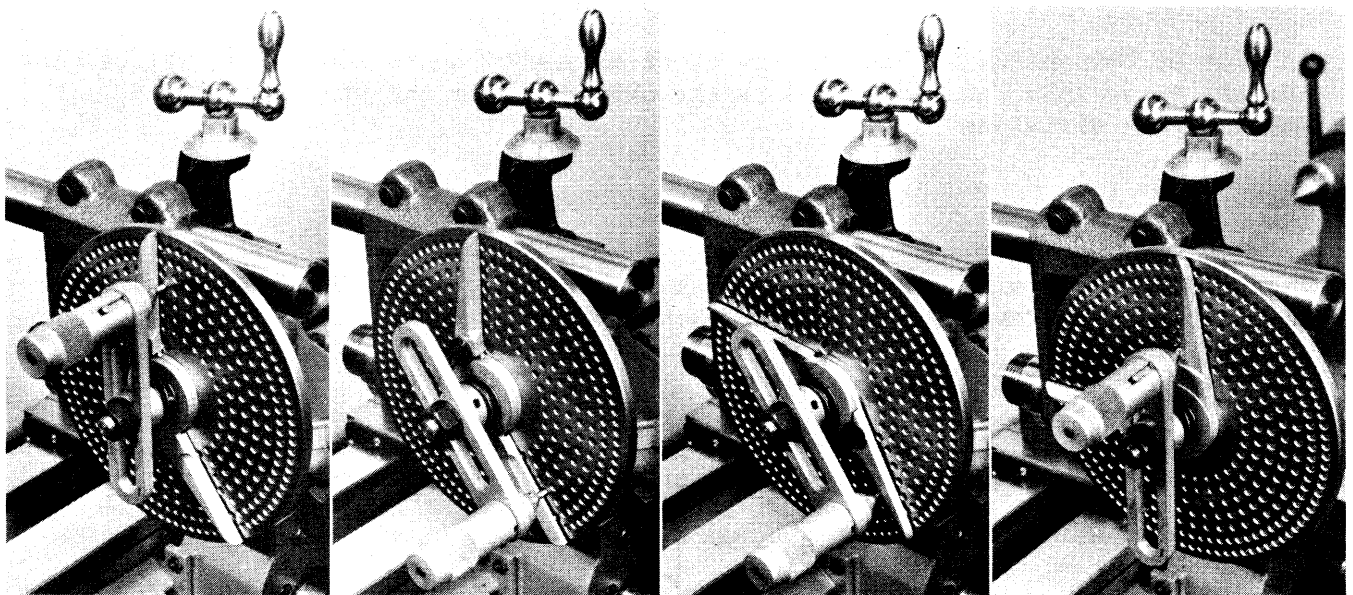

Fig.1

Fig.2

Fig.3

Fig.4

B. Operation over the arms (e.g. 16 divisions).

Open up the sector arms so that there is about 120° between them. Adjust the setting of the index crank so that the plunger will drop into the holes of the 32-hole circle. (No. 1 plate). With arm B to the right of the numbered holes and arm A at about '8 o'clock' rotate the crank clockwise till the plunger will drop into the numbered hole. Next rotate the sector arms anticlockwise so that arm B which is to the right of the plunger is touching it (still on the right hand side).

Starting at the hole to the left of the plunger count 8 (i.e. $32 - 24$) holes in an anticlockwise direction and, holding arm B firmly against the right hand side of the plunger, move arm A upwards, in a clockwise direction until its upper edge lines up with the lower edge of the required hole and tighten the screw to lock the sector arms together (N.B. In this example there will be a total of 9 holes between the sector arms). (Fig. 4)

Mounting the attachment.

Where circumstances permit and both slides are available it will generally be found preferable to use the plain vertical slide 67/1 as this will give greater rigidity. In addition, the maximum height of attachment spindle above the headstock spindle is slightly greater than on the swivelling slide 68/2.

When working with the axis of the attachment spindle parallel to the axis of the headstock spindle it will generally be preferable to have the attachment spindle at the same height as the headstock spindle, thus working on the horizontal centre line.

When using a cutter on an arbor between centres, with the axes of dividing attachment and headstock spindles at right angles one to the other, if the sum of the radii of cutter and work exceeds $2.1/8''$ (e.g. a 2" dia. cutter and a $2\frac{1}{2}''$ dia. component) the dividing attachment may be raised $2.1/8''$ by using No. 30/011 raising block for ML7 and Super 7 lathes. Where this is not available, or if when using it, the sum of the radii exceeds $4\frac{1}{4}''$, it will be necessary to increase the centre distance between cutter and work in some other way.

This may be achieved by repositioning the key in the back of the spindle bracket by fitting it in to the vertical slot and rotating the table of the swivelling slide 68/2 and mounting the attachment with the slide so swivelled that the attachment spindle is looking up at an angle. The axis of the feedscrew of the milling slide will then be parallel to the axis of the spindle of the dividing attachment. (See drawing on sheet S.2546E). The approximate setting for height may be made with both cutter and workpiece in position by rotating the slide table and dividing attachment and simultaneously advancing or withdrawing the cross slide, and, by means of its feed screw, adjusting the position of the milling slide table.

The feed of the workpiece across the cutter will be by means of the feed screw of the swivelling slide, the depth of cut will be controlled by the cross slide feed screw. It will be noted, however, that the depth of cut actually applied will be less than the movement of the cross slide and that the relationship will vary with differing angles.

The amount of cross slide movement for any required depth of cut may be calculated by using the formula

$$f = \frac{c}{\sin A}$$

Where

- f = amount cross slide is to be moved
- c = required depth of cut
- A = angle of inclination of slide and dividing attachment

Reference to trigonometric tables will show that an inclination of 30° to the horizontal should be chosen whenever possible since the amount of movement of the cross slide will be exactly twice the required depth of cut.

Mounting the workpiece.

Where the workpiece is suitable it should be mounted in a chuck or No. 1031 collet with 1438 nose piece. It is not advised that the work be mounted between centres. The outboard support is not intended for this purpose. Components which are bored should be mounted on a stub arbor machined to suit. This in turn may be mounted in a chuck, in the No. 1031 collet or it may have a No. 2 M.T. shank and be mounted direct in the taper in the spindle of the attachment.

The overarm and outboard support centre.

If the component has a centre at its outer end or is mounted on a stub arbor with such a centre, the outboard centre may be used for additional support.

Operation - indexing.

As an example of use, assume the cutting of the teeth on a 25 tooth spur gear.

Mount the cutter on an arbor between centres (or held in the chuck, with tailstock support).

Mount the vertical slide on to the lathe cross slide, the dividing attachment on to it and mount the work piece.

Centralise the work piece to the cutter and set for height so that the cutter just touches the periphery of the work piece.

Fit the number 1 division plate and set the index crank and the sector arms as described as A on sheet 2546B.

Set for the required depth of cut.

Rotate the index crank clockwise until the plunger drops into the numbered hole. (N.B. It may be found convenient when rotating the index crank to stop just short of the required hole and then to tap the index crank round until the plunger drops in).

Make the first cut.

Check that the sector arms are in their correct position (arm A touching the left hand side of the plunger) and withdraw the plunger. Rotate the knob to allow the shallow notch to engage with the stop peg. Now rotate the index crank clockwise two complete revolutions plus 18 holes that is up to arm B and allow the plunger to drop in to the hole in the index plate. (S.2546B Fig.2)

Cut the second tooth.

Rotate the sector arms clockwise so that arm A is again touching the plunger.(Fig.3)

Withdraw the plunger and index as before.

When operating over the sector arms (e.g. 16 divisions, see sheet S.2546C), the movements of the index crank will again be in a clockwise direction, though this time the sector arms will be moved anticlockwise. However, at the commencement, with the plunger in the numbered hole, arm B will be touching the right hand side of the plunger, whereas arm A will be at 'nine o'clock'. The movement of the index crank will be :-

Withdraw the plunger, rotate the index crank clockwise three complete revolutions plus 24 holes, that is just over arm A. Before the next movement of the index crank rotate the sector arms anticlockwise so that arm B is in contact with the plunger.

N.B. If two or more cuts are to be made in achieving full depth, the first, roughing, cut should be made right round the blank before adjusting for depth for the subsequent cut(s).

When operating, always rotate the index crank clockwise.

If you inadvertently go beyond the required hole do not come directly back to it. Go back well past it so that you can again come up to it in a clockwise direction.

The bore for the main spindle of the attachment is split, the resulting slot being fitted with a packing piece. This is so relieved that the centre screw can be used, if required, as a locking screw for extra rigidity during actual machining. The two outer screws are for bearing clearance adjustment and, having been carefully set during manufacture, should not normally be touched.

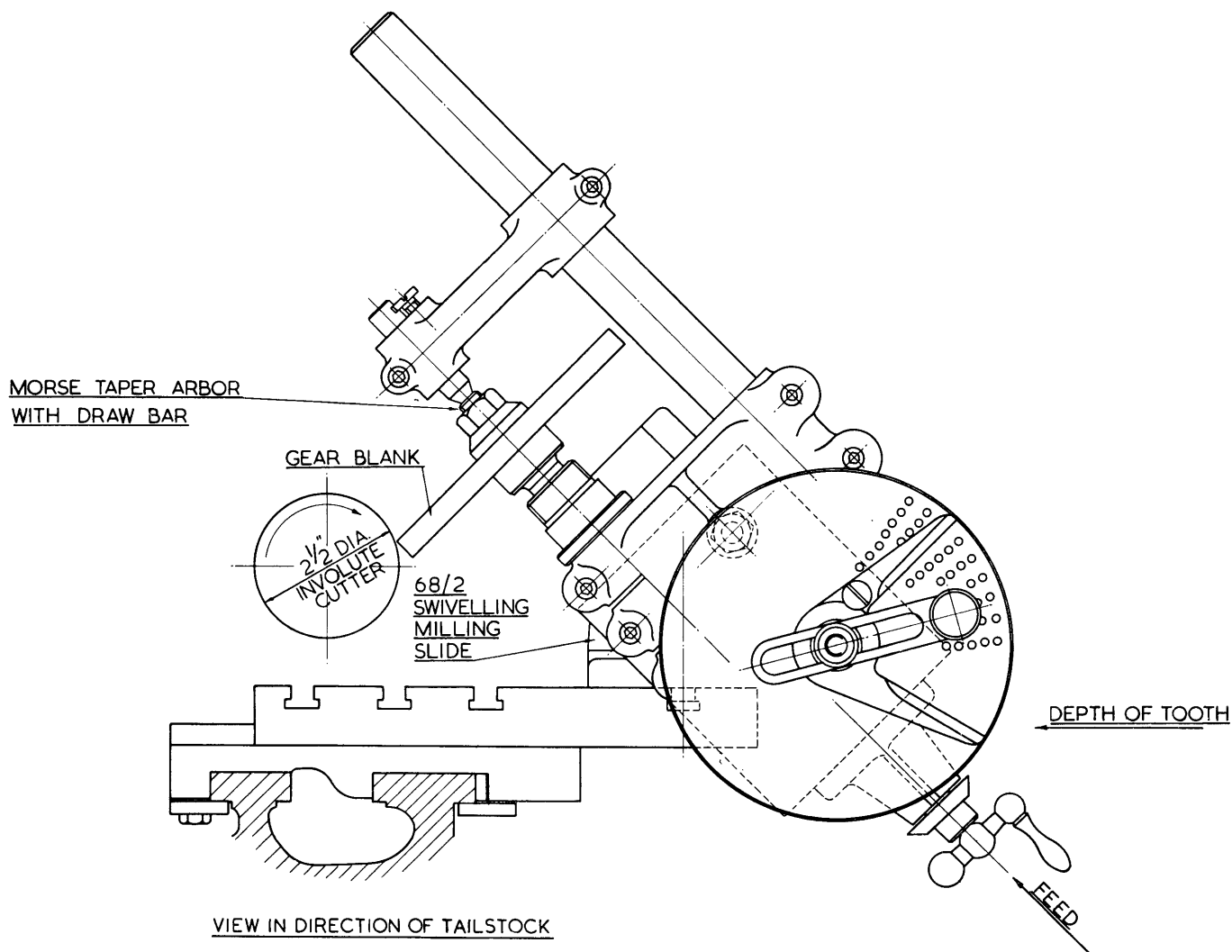

Adjustments.

No adjustments should be necessary until the attachment has had an appreciable amount of use. There are, however, four which can be made.

Should the spindle bearing clearance eventually need adjustment, it will be necessary to remove and thin the packing piece.

End float in the spindle can be eliminated by adjusting the collar at the rear end of the spindle. This is threaded (right hand) on to the spindle and is secured by means of a grub screw which must be released for the adjustment to be made and retightened afterwards.

Backlash between worm and wormwheel can be eliminated by releasing the hexagon head screws which secure the worm bracket to the main body of the attachment and lowering the bracket. Note that the bracket is keyed to the body.

The position of the plunger in the index crank can be adjusted if, with the plunger located so that the shallow notch is engaged with the stop peg, the plunger will not pass over the sector arms (allow about 1/16", 1.5 mm, clearance). To adjust, release the socket set screw in the end of the plunger knob, release the plunger, in order to reduce the load on the spring, but hold the knob so that the plunger is not fully engaged with the dividing plate and screw the plunger into the knob the requisite amount. Re-tighten the socket set screw to lock the plunger in position in the knob.

SUPPLEMENTARY CHART COVERING NUMBERS FROM 101 to 200

Since the denominator of the fraction in the column headed "TURN INDEX CRANK" is the number of holes in the index circle required, an entry has only been made in the column headed "INDEX CIRCLE" if a plate having this number of holes has to be made. A blank space in the column headed "TURN INDEX CRANK" indicates a number which cannot be obtained either directly or indirectly.

| No. OF DIVISIONS | TURN INDEX CRANK | INDEX CIRCLE | No. OF DIVISIONS | TURN INDEX CRANK | INDEX CIRCLE | No. OF DIVISIONS | TURN INDEX CRANK | INDEX CIRCLE | No. OF DIVISIONS | TURN INDEX CRANK | INDEX CIRCLE | No. OF DIVISIONS | TURN INDEX CRANK | INDEX CIRCLE |
|------------------|------------------|--------------|------------------|------------------|--------------|------------------|------------------|--------------|------------------|------------------|--------------|------------------|------------------|--------------|
| 101 | | | 121 | | | 141 | $\frac{20}{47}$ | | 161 | | | 181 | | |
| 102 | $\frac{20}{34}$ | | 122 | $\frac{30}{61}$ | | 142 | $\frac{30}{71}$ | | 162 | $\frac{10}{27}$ | | 182 | $\frac{30}{91}$ | |
| 103 | | | 123 | $\frac{20}{41}$ | | 143 | | | 163 | | | 183 | $\frac{20}{61}$ | |
| 104 | $\frac{15}{26}$ | 26 | 124 | $\frac{15}{31}$ | | 144 | $\frac{5}{12}$ | 12 | 164 | $\frac{15}{41}$ | | 184 | $\frac{15}{46}$ | |
| 105 | $\frac{24}{42}$ | | 125 | $\frac{12}{25}$ | 25 | 145 | $\frac{12}{29}$ | | 165 | $\frac{28}{77}$ | | 185 | $\frac{12}{37}$ | |
| 106 | $\frac{30}{53}$ | | 126 | $\frac{20}{42}$ | | 146 | $\frac{30}{73}$ | | 166 | $\frac{30}{83}$ | | 186 | $\frac{10}{31}$ | |
| 107 | | | 127 | | | 147 | $\frac{20}{49}$ | | 167 | | | 187 | | |
| 108 | $\frac{25}{45}$ | | 128 | $\frac{15}{32}$ | | 148 | $\frac{5}{37}$ | | 168 | $\frac{15}{42}$ | | 188 | $\frac{15}{47}$ | |
| 109 | | | 129 | $\frac{20}{43}$ | | 149 | | | 169 | | | 189 | $\frac{20}{63}$ | 63 |
| 110 | $\frac{42}{77}$ | | 130 | $\frac{42}{91}$ | | 150 | $\frac{18}{45}$ | | 170 | $\frac{12}{34}$ | | 190 | $\frac{12}{38}$ | |
| 111 | $\frac{20}{37}$ | | 131 | | | 151 | | | 171 | $\frac{20}{57}$ | 57 | 191 | | |
| 112 | $\frac{15}{28}$ | 28 | 132 | $\frac{35}{77}$ | | 152 | $\frac{15}{38}$ | | 172 | $\frac{15}{43}$ | | 192 | $\frac{10}{32}$ | |
| 113 | | | 133 | | | 153 | $\frac{20}{51}$ | 51 | 173 | | | 193 | | |
| 114 | $\frac{20}{38}$ | | 134 | $\frac{30}{67}$ | | 154 | $\frac{30}{77}$ | | 174 | $\frac{10}{29}$ | | 194 | $\frac{30}{87}$ | |
| 115 | $\frac{24}{46}$ | | 135 | $\frac{20}{45}$ | | 155 | $\frac{12}{31}$ | | 175 | $\frac{12}{35}$ | 35 | 195 | $\frac{28}{91}$ | |
| 116 | $\frac{15}{29}$ | | 136 | $\frac{15}{34}$ | | 156 | $\frac{35}{91}$ | | 176 | $\frac{15}{44}$ | 44 | 196 | $\frac{15}{49}$ | |
| 117 | $\frac{20}{39}$ | 39 | 137 | | | 157 | | | 177 | $\frac{20}{59}$ | | 197 | | |
| 118 | $\frac{30}{59}$ | | 138 | $\frac{20}{46}$ | | 158 | $\frac{30}{79}$ | | 178 | $\frac{30}{89}$ | | 198 | $\frac{20}{66}$ | |
| 119 | | | 139 | | | 159 | $\frac{20}{53}$ | | 179 | | | 199 | | |
| 120 | $\frac{16}{32}$ | | 140 | $\frac{18}{42}$ | | 160 | $\frac{12}{32}$ | | 180 | $\frac{15}{45}$ | | 200 | $\frac{1}{10}$ | 10 |

PLATE N^o 1. CIRCLES

91:77:49:45:38:34:32

PLATE N^o 2. CIRCLES

47:46:43:42:41:37:31:29

MYFORD

DIVIDING ATTACHMENT

WORM AND WHEEL RATIO :- 60/1

PLATES 3 AND 4 ARE SUPPLIED AS EXTRA

PLATE N^o 3 CIRCLES

97:83:73:67:61:27

PLATE N^o 4 CIRCLES

89:79:71:66:59:53

| N ^o OF DIVISIONS | INDEX CIRCLE | N ^o OF TURNS OF INDEX CRANK | N ^o OF DIVISIONS | INDEX CIRCLE | N ^o OF TURNS OF INDEX CRANK | N ^o OF DIVISIONS | INDEX CIRCLE | N ^o OF TURNS OF INDEX CRANK | N ^o OF DIVISIONS | INDEX CIRCLE | N ^o OF TURNS OF INDEX CRANK | N ^o OF DIVISIONS | INDEX CIRCLE | N ^o OF TURNS OF INDEX CRANK |
|-----------------------------|--------------|--|-----------------------------|--------------|--|-----------------------------|--------------|--|-----------------------------|--------------|--|-----------------------------|--------------|--|
| 1 | ANY | 60 | 21 | 49 | 2 $\frac{42}{49}$ | 41 | 41 | 1 $\frac{10}{41}$ | 61 | 61 | $\frac{60}{61}$ | 81 | 27 | 2 $\frac{20}{27}$ |
| 2 | " | 30 | 22 | 77 | 2 $\frac{56}{77}$ | 42 | 49 | 1 $\frac{21}{49}$ | 62 | 31 | $\frac{30}{31}$ | 82 | 41 | 3 $\frac{30}{41}$ |
| 3 | " | 20 | 23 | 46 | 2 $\frac{28}{46}$ | 43 | 43 | 1 $\frac{17}{43}$ | 63 | 42 | $\frac{40}{42}$ | 83 | 83 | 6 $\frac{60}{83}$ |
| 4 | " | 15 | 24 | 32 | 2 $\frac{16}{32}$ | 44 | 77 | 1 $\frac{28}{77}$ | 64 | 32 | $\frac{30}{32}$ | 84 | 49 | 3 $\frac{35}{49}$ |
| 5 | " | 12 | 25 | 45 | 2 $\frac{18}{45}$ | 45 | 45 | 1 $\frac{15}{45}$ | 65 | 91 | $\frac{64}{91}$ | 85 | 34 | 2 $\frac{24}{34}$ |
| 6 | " | 10 | 26 | 91 | 2 $\frac{28}{91}$ | 46 | 46 | 1 $\frac{14}{46}$ | 66 | 77 | $\frac{70}{77}$ | 86 | 43 | 3 $\frac{30}{43}$ |
| 7 | 49 | 8 $\frac{28}{49}$ | 27 | 45 | 2 $\frac{10}{45}$ | 47 | 47 | 1 $\frac{13}{47}$ | 67 | 67 | $\frac{60}{67}$ | 87 | 29 | 2 $\frac{20}{29}$ |
| 8 | 32 | 7 $\frac{16}{32}$ | 28 | 42 | 2 $\frac{6}{42}$ | 48 | 32 | 1 $\frac{8}{32}$ | 68 | 34 | $\frac{30}{34}$ | 88 | 66 | 4 $\frac{45}{66}$ |
| 9 | 45 | 6 $\frac{30}{45}$ | 29 | 29 | 2 $\frac{2}{29}$ | 49 | 49 | 1 $\frac{11}{49}$ | 69 | 46 | $\frac{40}{46}$ | 89 | 89 | 6 $\frac{60}{89}$ |
| 10 | ANY | 6 | 30 | ANY | 2 | 50 | 45 | 1 $\frac{9}{45}$ | 70 | 49 | $\frac{42}{49}$ | 90 | 45 | 3 $\frac{30}{45}$ |
| 11 | 77 | 5 $\frac{35}{77}$ | 31 | 31 | 1 $\frac{29}{31}$ | 51 | 34 | 1 $\frac{6}{34}$ | 71 | 71 | $\frac{60}{71}$ | 91 | 91 | 6 $\frac{60}{91}$ |
| 12 | ANY | 5 | 32 | 32 | 1 $\frac{28}{32}$ | 52 | 91 | 1 $\frac{14}{91}$ | 72 | 42 | $\frac{35}{42}$ | 92 | 46 | 3 $\frac{30}{46}$ |
| 13 | 91 | 4 $\frac{56}{91}$ | 33 | 77 | 1 $\frac{63}{77}$ | 53 | 53 | 1 $\frac{7}{53}$ | 73 | 73 | $\frac{60}{73}$ | 93 | 31 | 2 $\frac{20}{31}$ |
| 14 | 49 | 4 $\frac{14}{49}$ | 34 | 34 | 1 $\frac{26}{34}$ | 54 | 45 | 1 $\frac{5}{45}$ | 74 | 37 | $\frac{30}{37}$ | 94 | 47 | 3 $\frac{30}{47}$ |
| 15 | ANY | 4 | 35 | 49 | 1 $\frac{35}{49}$ | 55 | 77 | 1 $\frac{7}{77}$ | 75 | 45 | $\frac{36}{45}$ | 95 | 38 | 2 $\frac{24}{38}$ |
| 16 | 32 | 3 $\frac{24}{32}$ | 36 | 45 | 1 $\frac{30}{45}$ | 56 | 42 | 1 $\frac{3}{42}$ | 76 | 38 | $\frac{30}{38}$ | 96 | 32 | 2 $\frac{20}{32}$ |
| 17 | 34 | 3 $\frac{18}{34}$ | 37 | 37 | 1 $\frac{23}{37}$ | 57 | 38 | 1 $\frac{2}{38}$ | 77 | 77 | $\frac{60}{77}$ | 97 | 97 | 6 $\frac{60}{97}$ |
| 18 | 45 | 3 $\frac{15}{45}$ | 38 | 38 | 1 $\frac{22}{38}$ | 58 | 29 | 1 $\frac{1}{29}$ | 78 | 91 | $\frac{70}{91}$ | 98 | 49 | 3 $\frac{30}{49}$ |
| 19 | 38 | 3 $\frac{6}{38}$ | 39 | 91 | 1 $\frac{49}{91}$ | 59 | 59 | 1 $\frac{1}{59}$ | 79 | 79 | $\frac{60}{79}$ | 99 | 66 | 4 $\frac{40}{66}$ |
| 20 | ANY | 3 | 40 | 32 | 1 $\frac{16}{32}$ | 60 | ANY | 1 | 80 | 32 | $\frac{24}{32}$ | 100 | 45 | 2 $\frac{27}{45}$ |

FOR ANGULAR DIVIDING USE 42 CIRCLE 1° = $\frac{7}{42}$

PLATE N^o 1. CIRCLES

91:77:49:45:38:34:32

PLATE N^o 2. CIRCLES

47:46:43:42:41:37:31:29

MYFORD

DIVIDING ATTACHMENT

WORM AND WHEEL RATIO :- 60/1

PLATES 3 AND 4 ARE SUPPLIED AS EXTRA

PLATE N^o 3 CIRCLES

97:83:73:67:61:27

PLATE N^o 4 CIRCLES

89:79:71:66:59:53

| N ^o OF DIVISIONS | INDEX CIRCLE | N ^o OF TURNS OF INDEX CRANK | N ^o OF DIVISIONS | INDEX CIRCLE | N ^o OF TURNS OF INDEX CRANK | N ^o OF DIVISIONS | INDEX CIRCLE | N ^o OF TURNS OF INDEX CRANK | N ^o OF DIVISIONS | INDEX CIRCLE | N ^o OF TURNS OF INDEX CRANK | N ^o OF DIVISIONS | INDEX CIRCLE | N ^o OF TURNS OF INDEX CRANK |
|-----------------------------|--------------|--|-----------------------------|--------------|--|-----------------------------|--------------|--|-----------------------------|--------------|--|-----------------------------|--------------|--|
| 1 | ANY | 60 | 21 | 49 | 2 $\frac{42}{49}$ | 41 | 41 | 1 $\frac{19}{41}$ | 61 | 61 | $\frac{60}{61}$ | 81 | 27 | $\frac{20}{27}$ |
| 2 | " | 30 | 22 | 77 | 2 $\frac{56}{77}$ | 42 | 49 | 1 $\frac{21}{49}$ | 62 | 31 | $\frac{30}{31}$ | 82 | 41 | $\frac{30}{41}$ |
| 3 | " | 20 | 23 | 46 | 2 $\frac{28}{46}$ | 43 | 43 | 1 $\frac{17}{43}$ | 63 | 42 | $\frac{40}{42}$ | 83 | 83 | $\frac{60}{83}$ |
| 4 | " | 15 | 24 | 32 | 2 $\frac{16}{32}$ | 44 | 77 | 1 $\frac{28}{77}$ | 64 | 32 | $\frac{30}{32}$ | 84 | 49 | $\frac{35}{49}$ |
| 5 | " | 12 | 25 | 45 | 2 $\frac{18}{45}$ | 45 | 45 | 1 $\frac{15}{45}$ | 65 | 91 | $\frac{84}{91}$ | 85 | 34 | $\frac{24}{34}$ |
| 6 | " | 10 | 26 | 91 | 2 $\frac{28}{91}$ | 46 | 46 | 1 $\frac{14}{46}$ | 66 | 77 | $\frac{70}{77}$ | 86 | 43 | $\frac{30}{43}$ |
| 7 | 49 | 8 $\frac{28}{49}$ | 27 | 45 | 2 $\frac{10}{45}$ | 47 | 47 | 1 $\frac{13}{47}$ | 67 | 67 | $\frac{60}{67}$ | 87 | 29 | $\frac{20}{29}$ |
| 8 | 32 | 7 $\frac{16}{32}$ | 28 | 42 | 2 $\frac{6}{42}$ | 48 | 32 | 1 $\frac{8}{32}$ | 68 | 34 | $\frac{30}{34}$ | 88 | 66 | $\frac{45}{66}$ |
| 9 | 45 | 6 $\frac{30}{45}$ | 29 | 29 | 2 $\frac{2}{29}$ | 49 | 49 | 1 $\frac{11}{49}$ | 69 | 46 | $\frac{40}{46}$ | 89 | 89 | $\frac{60}{89}$ |
| 10 | ANY | 6 | 30 | ANY | 2 | 50 | 45 | 1 $\frac{9}{45}$ | 70 | 49 | $\frac{42}{49}$ | 90 | 45 | $\frac{30}{45}$ |
| 11 | 77 | 5 $\frac{35}{77}$ | 31 | 31 | 1 $\frac{29}{31}$ | 51 | 34 | 1 $\frac{6}{34}$ | 71 | 71 | $\frac{60}{71}$ | 91 | 91 | $\frac{60}{91}$ |
| 12 | ANY | 5 | 32 | 32 | 1 $\frac{28}{32}$ | 52 | 91 | 1 $\frac{14}{91}$ | 72 | 42 | $\frac{35}{42}$ | 92 | 46 | $\frac{30}{46}$ |
| 13 | 91 | 4 $\frac{56}{91}$ | 33 | 77 | 1 $\frac{63}{77}$ | 53 | 53 | 1 $\frac{7}{53}$ | 73 | 73 | $\frac{60}{73}$ | 93 | 31 | $\frac{20}{31}$ |
| 14 | 49 | 4 $\frac{14}{49}$ | 34 | 34 | 1 $\frac{26}{34}$ | 54 | 45 | 1 $\frac{5}{45}$ | 74 | 37 | $\frac{30}{37}$ | 94 | 47 | $\frac{30}{47}$ |
| 15 | ANY | 4 | 35 | 49 | 1 $\frac{35}{49}$ | 55 | 77 | 1 $\frac{7}{77}$ | 75 | 45 | $\frac{36}{45}$ | 95 | 38 | $\frac{24}{38}$ |
| 16 | 32 | 3 $\frac{24}{32}$ | 36 | 45 | 1 $\frac{30}{45}$ | 56 | 42 | 1 $\frac{3}{42}$ | 76 | 38 | $\frac{30}{38}$ | 96 | 32 | $\frac{20}{32}$ |
| 17 | 34 | 3 $\frac{18}{34}$ | 37 | 37 | 1 $\frac{23}{37}$ | 57 | 38 | 1 $\frac{2}{38}$ | 77 | 77 | $\frac{60}{77}$ | 97 | 97 | $\frac{60}{97}$ |
| 18 | 45 | 3 $\frac{15}{45}$ | 38 | 38 | 1 $\frac{22}{38}$ | 58 | 29 | 1 $\frac{1}{29}$ | 78 | 91 | $\frac{70}{91}$ | 98 | 49 | $\frac{30}{49}$ |
| 19 | 38 | 3 $\frac{6}{38}$ | 39 | 91 | 1 $\frac{49}{91}$ | 59 | 59 | 1 $\frac{1}{59}$ | 79 | 79 | $\frac{60}{79}$ | 99 | 66 | $\frac{40}{66}$ |
| 20 | ANY | 3 | 40 | 32 | 1 $\frac{16}{32}$ | 60 | ANY | 1 | 80 | 32 | $\frac{24}{32}$ | 100 | 45 | $\frac{27}{45}$ |

FOR ANGULAR DIVIDING USE 42 CIRCLE 1° = $\frac{7}{42}$