

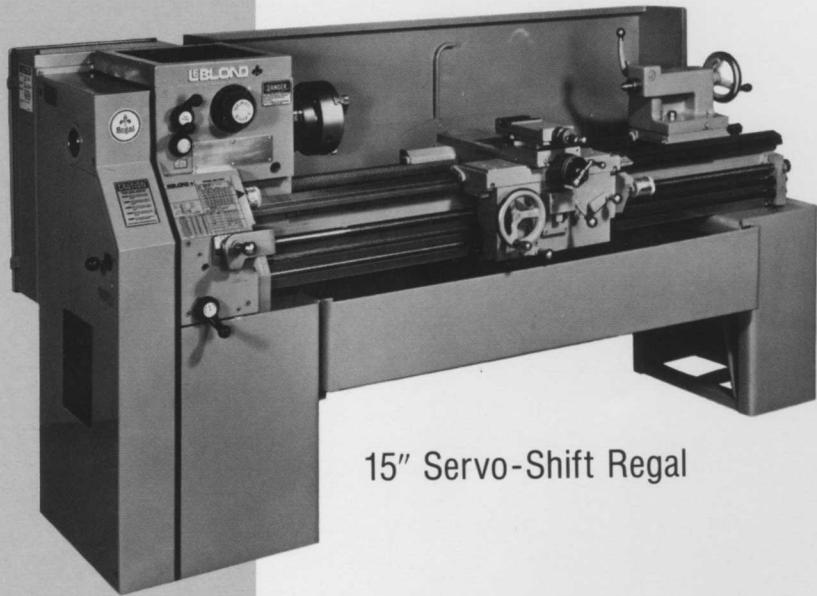

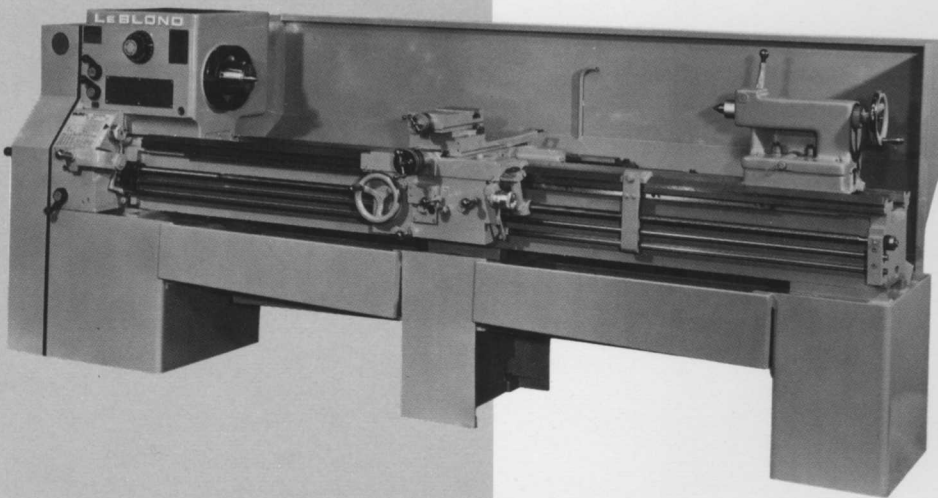

LEBLOND
MACHINE TOOL
GENERAL CATALOG



15" Servo-Shift Regal

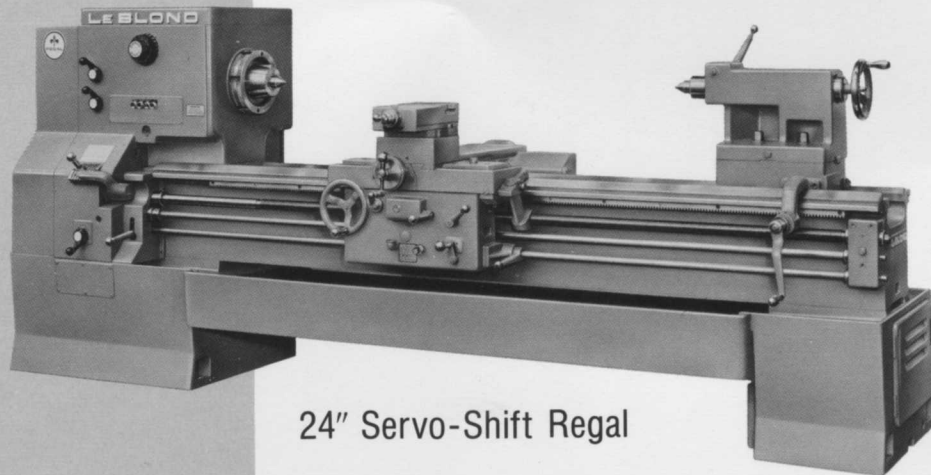

19" Servo-Shift Regal



24" Servo-Shift Regal

MAJOR FEATURES

- Designed and built with the same care as LeBlond Heavy Duty Lathes, Regals give long life, precision production, minimum maintenance and dependability expected only from much higher priced machines.
- All standard Regal Engine Lathes have Servo-Shift as standard, allowing further time savings with pre-selection of spindle speeds.
- Combination gear-belt drive with 8 geared and 4 timing belts speeds. Spindle supported by three anti-friction, high capacity bearings for heavy loads. Precision aligned to exacting standards.
- Bed has compensating guideways, assuring long-time accuracy and minimum wear. Equipped with both feed rod and leadscrew. Automatically lubricated quick-change box through which 48 inch and 40 metric feed and thread changes are provided.
- Rigid apron and carriage guarantee accurate tool guidance and efficient feed-power transmission. Rugged tailstock features positive spindle clamping. Large chip pan slides out for easy chip removal.

STANDARD EQUIPMENT

Servo-Shift • small face plate • hardened and ground replaceable steel bedways • graduated compound rest • tool post • taper spindle sleeve • leveling plates • apron spindle control • chasing dial • chip pan • feed drive safety clutch • centers • necessary wrenches • machine arranged for multiple V-belt motor drive including motor • Inch/metric dual dials* and inch/metric quick change box translating gears.

OPTIONAL EQUIPMENT

Taper attachment • large face plate • connected rest* • steady rest • follow rest • ball chasing stop* • micrometer carriage stop • six position multiple length stop • coolant • chucks • tools.

*24" Regals only

SPECIFICATIONS	15"	19"	24"
GENERAL CAPACITY			
Swing over bed and carriage wings	15 1/2" 390mm	19 1/4" 490mm	26" 660mm
Swing over cross slide	9 1/2" 240mm	12 1/4" 310mm	18 1/4" 465mm
Center distance range	30" or 54" 760mm or 1370mm	54" to 150" 1372mm to 3810mm	72" to 240" 1830mm to 6095mm
HEADSTOCK			
Spindle speeds, number	12	12	12
Spindle speeds, range in rpm	45 to 1800	40 to 1600	27 to 1080
Spindle, size of center, Morse No.	3	4	5
Spindle, diameter of hole, straight	2 1/4" 60mm	3 1/16" 80mm	2-3/16" 55mm
Spindle nose, taper key drive, size	L-1	L-2	L-2
BED			
Width	12-3/16" 310mm	14 3/8" 365mm	17" 430mm
CARRIAGE			
Bridge width	6 1/4" 160mm	7 7/8" 200mm	9" 230mm
Cross slide travel	8 7/8" 225mm	11 1/4" 285mm	13 1/4" 335mm
FEED AND THREAD RANGE			
Feed changes, number	48 Inch 40 Metric	48 Inch 40 Metric	48
Thread changes, number	48 Inch 40 Metric	48 Inch 40 Metric	48
Range of threads per inch	2 to 112	2 to 112	2 to 112
Range of feeds per revolution	.0018 IPR-.05mm/r .104 IPR- 2.8 mm/r	.0018 IPR-.05mm/r .104 IPR -2.8 mm/r	.0036" to .205" .09mm to 5.2mm
TAILSTOCK			
Spindle diameter	1-15/16" 50mm	2-7/16" 60mm	3 1/8" 80mm
Spindle travel	5" 125mm	7" 180mm	7 1/2" 190mm
MOTOR DATA			
HP (Duty Rated) T.E.F.C.	7 1/2 5.6kw	10 7.45kw	15 11.25kw
SHIPPING DATA (For basic machine with average accessories)			
Net weight, approximate	3005 lbs. 1350kg	3860 lbs. 1750kg	7,370 lbs. 2695kg
Floor space required (With taper attachment)	78" x 40" 1980mm x 1015mm	113" x 50" 2870mm x 1270mm	158" x 60" 4015mm x 1525mm



24" Regal with 5 1/4" Thru Spindle

24" THRU SPINDLE AND HOLLOW SPINDLE REGAL LATHES

For machining shafts or tubes which are much longer than the between-center distance, LeBlond offers the 24" Regal Lathe with either a 5 1/4" Thru Spindle or a 9" Hollow Spindle. Built to the same rugged specifications as the standard 24" models, the Thru Spindle and Hollow Spindle models accommodate turning of longer shafts or tubes which normally must be turned on longer bed, more expensive equipment.

Normal between-center work can also be accomplished on both the Thru Spindle and Hollow Spindle models by inserting a center adapter in the nose end of the spindle.

Specifications of the standard 24" Regal Engine Lathe apply to the Thru Spindle and Hollow Spindle models except for those shown here.

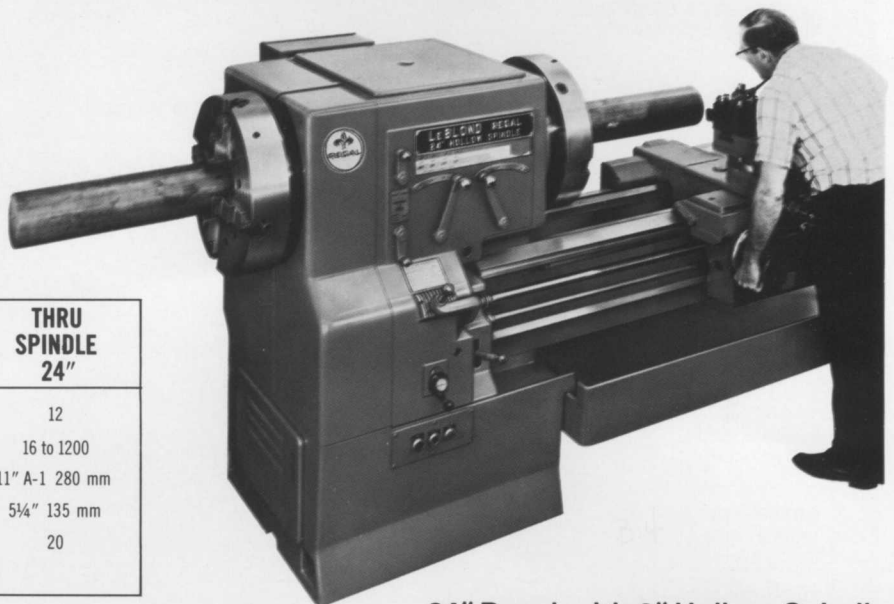

24" Regal with 9" Hollow Spindle
and Rear Mounted Chuck

SPECIFICATIONS	HOLLOW SPINDLE 24"	THRU SPINDLE 24"
Spindle speeds, number	12	12
Spindle speeds, range in rpm	6 to 400	16 to 1200
Spindle nose	15" Flange 380 mm	11" A-1 280 mm
Size of hole through spindle	9" 230 mm	5 1/4" 135 mm
Max. hp	15	20

PRODUCTION LATHES

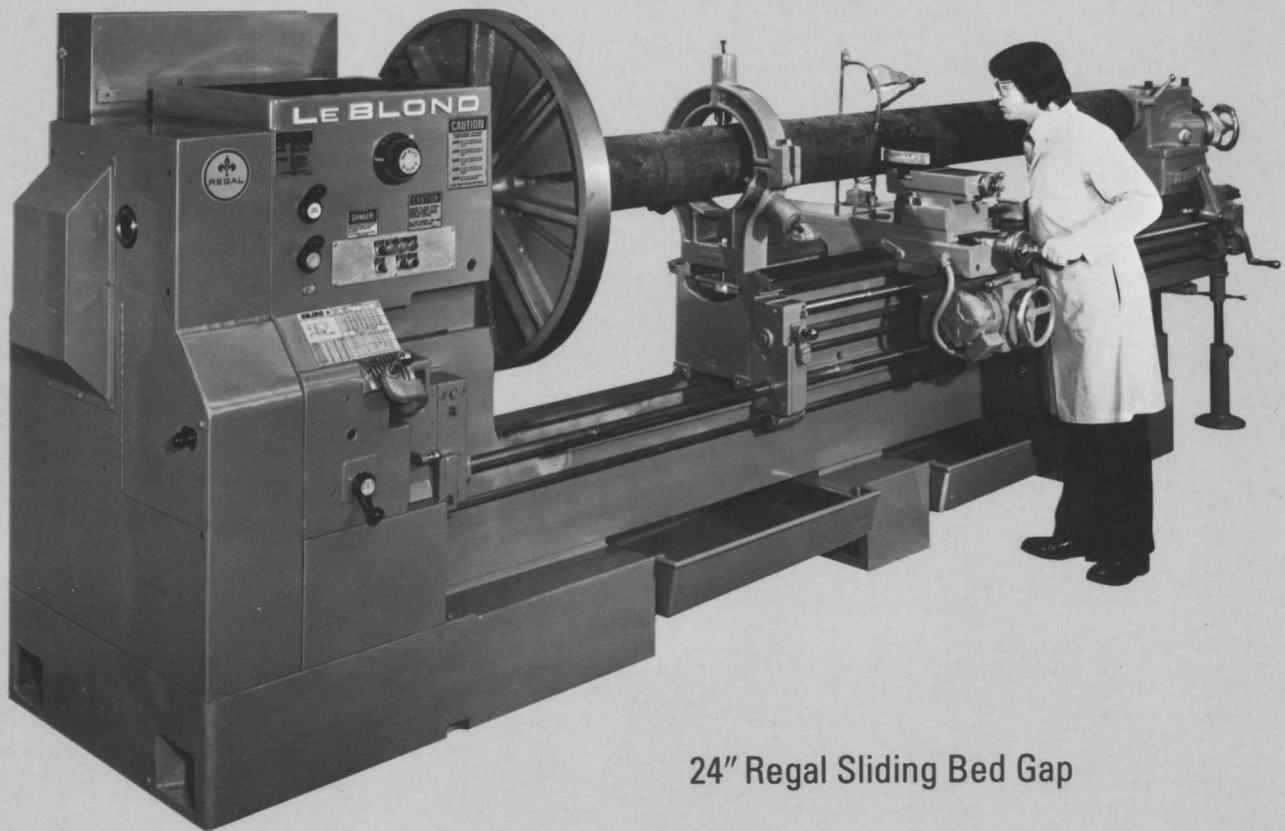

24" Regal Sliding Bed Gap

24" SLIDING BED GAP REGAL LATHES

For the ultimate in turning flexibility, LeBlond offers the Sliding Bed Gap version of the 24" Regal Engine Lathe. Available with or without the Thru Spindle or Hollow Spindle feature, the 24" Regal Sliding Bed Gap lathe enables you to turn a variety of parts that might require a whole department of lathes in another shop.

With the bed closed, it functions as a regular engine lathe. With the bed slide open, it forms a gap that will accept odd-shaped parts and large diameter work pieces. At the same time, sliding the bed open provides more than 50% greater distance between centers.

Specifications of the standard 24" Regal Engine Lathe apply to the Sliding Bed Gap models except for those shown here.

SPECIFICATIONS—SLIDING BED GAP	24"/52"
Swing through gap	52" 1320 mm
Distance, face plate to end of gap, bed extended	55" 1400 mm
Center distance, bed closed	96" 2440 mm
Center distance, bed extended	156" 3960 mm
Bed width	17" 430 mm
Carriage length on ways	27" 685 mm
Cross slide travel	19½" 495 mm

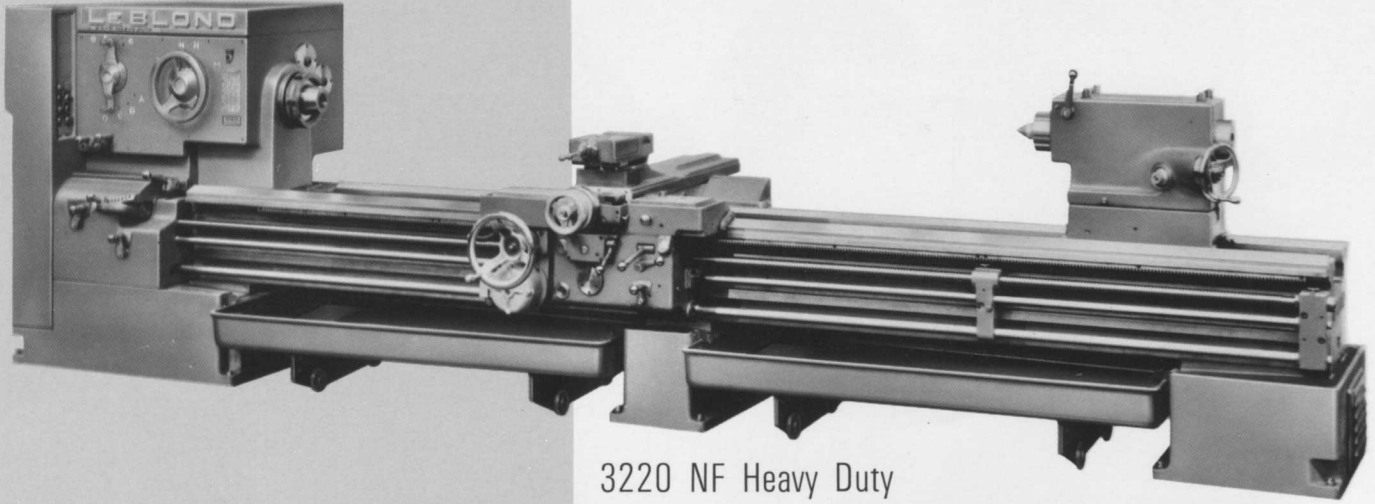

3220 NF Heavy Duty

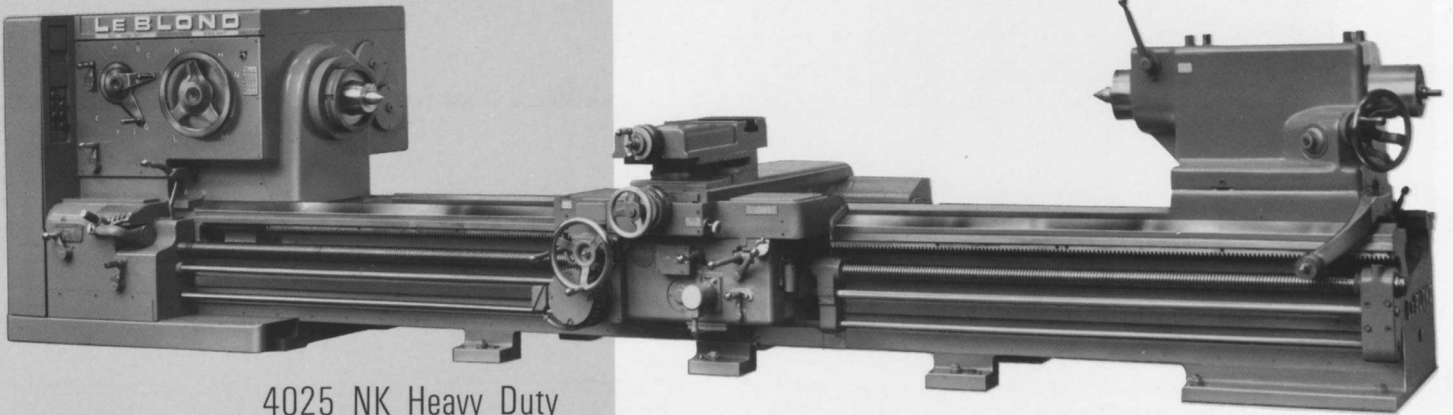

4025 NK Heavy Duty

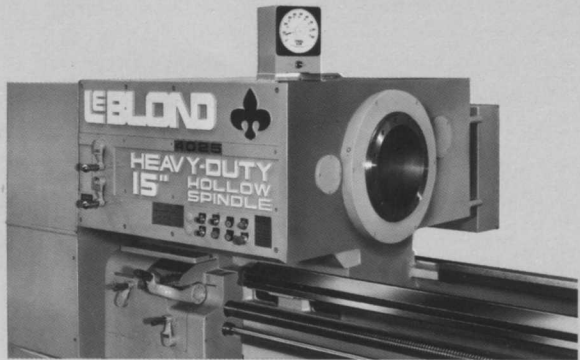

4025 NK Hollow Spindle

NK HOLLOW SPINDLE LATHE

Parts can be turned which are considerably longer than the normal distance between centers. This is accomplished by extending the workpiece through the hollow spindle, which has a 15" hole. Chucks may be fitted to both ends of the spindle.

SPECIFICATIONS	15" 380 mm 4025
Spindle speeds, range in rpm	10 to 850
Spindle nose flange diameter	19"
Size of hole through spindle	15" 380 mm
Max. hp and rpm recommended	75

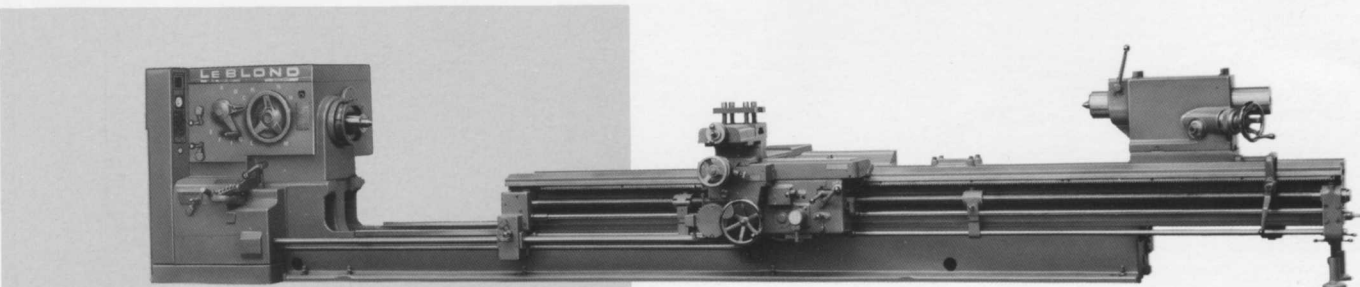

NK Sliding Bed Gap Lathe

HEAVY DUTY LATHES

MAJOR FEATURES

- 36 speeds with accurately ground spindle driven through heavy spur gears. Spindle runs in 4 high capacity, precision, anti-friction bearings.
- At any given speed, only gears and shafts transmitting power are engaged.
- Combination electric clutch and brake for starting, stopping and jogging, with rheostats to give full control over the widest range of workpiece sizes.
- Bed cast "L" shape to provide extra-solid headstock support at rear.
- Replaceable bed ways of hardened and ground steel. Compensating vee-way design assures accurate alignment and at the same time directs cutting forces into the massive bed.
- Sturdy carriage guided on the front way only; drive from rack or leadscrew is directly below front way.
- Hardened and ground, replaceable, square lock, cross slide ways reduce wear; provide more strength and allow more accurate movement with less maintenance.
- Four-way power rapid traverse saves tool positioning time.

• Feed and thread changes through totally enclosed quick change box. Feeds can be reversed at the apron.

• Tailstock worm and rack locks the spindle against thrust, provides extra spindle travel and gives full support even when spindle is fully extended.

STANDARD EQUIPMENT

Hardened and ground crossfeed screw and compensating crossfeed nut • hardened and ground replaceable steel bed ways, front and rear • small face plate • compound rest • No. 2 tool post • chasing dial • ball chasing stop • shear wipers • electric clutch and brake • motor drive sheave • hardened and ground cross slide ways • tailstock mover • four-directional power rapid traverse • centers and necessary wrenches.

OPTIONAL EQUIPMENT

Six-speed headstock • two-speed tailstock • anti-friction tailstock spindle • large face plate • tracers • taper attachment • chip pan • steady rest • follow rest • face plate jaws • turret tool block • pump, piping and tank • connected rests • metric transposing gears • air lift tailstock • inch/metric dials • two axis digital readout system • additional carriage.

SPECIFICATIONS	3220 NF†	4025 NK‡		3220 NF	4025 NK
GENERAL CAPACITY			FEED AND THREAD RANGE		
Swing over bed and carriage wings . . .	32" 815 mm	40" 1015 mm	Feed and thread changes, number	60	48
Swing over cross slide	20" 210 mm	25" 635 mm	Range of feeds per revolution0045" to .269"	.004" to .250"
*Range of center distances	48" to 480"	60" to 396"	Range of threads per inch10 to 7.0 mm 1 to 60	.10 to 6.0 mm ¾ to 46
	1220-12,190 mm	1525-10,060 mm			
HEADSTOCK			TAILSTOCK		
Spindle speeds, number	36	36	Spindle diameter	6" 150 mm	8" 205 mm
Spindle speeds, range in rpm	10 to 1300	5.4 to 600	Spindle travel	15" 380 mm	18" 460 mm
Spindle, size of center, Morse No.	5	6			
Spindle, dia. of hole, straight	2 ³ / ₁₆ " 55 mm	3 ¹ / ₁₆ " 90 mm	MOTOR DATA		
Spindle nose, taper key drive, size	L-2	L-3	HP	40	75
BED			SHIPPING DATA (For basic machine with average accessories)		
Width	24½" 620 mm	34" 865 mm	Net weight, approximate	20,400 lbs. 9275 Kg.	33,750 lbs. 15,340 Kg.
CARRIAGE					
Bearing surface, square inches	260	415			
Bridge width	11" 280 mm	15" 380 mm			
Cross slide travel	18½" 470 mm	23½" 600 mm			

*Longer lengths available upon request.

†Available with 25" swing over cross slide

‡Available with 32" and 36" swing over cross slide

NK SLIDING BED GAP LATHE

With bed closed, this machine functions as a regular engine lathe. Its special bed slides open to form a gap for odd shaped parts and large diameter jobs. Between center distance is increased up to 50% with bed fully extended.

SPECIFICATIONS	4025/65		4025/65
Swing over bed and carriage wings	39" 990 mm	Center distance, bed closed (basic machine)	72" 1830 mm
Swing over cross slide	25" 635 mm	Center distance, bed extended (basic machine)	132" 3355 mm
Swing through gap	65" 1650 mm	Bed width	31" 790 mm
Distance, face plate to end of gap, bed extended (basic mach.)	36" 915 mm	Carriage length on ways	46¾" 1190 mm
		Cross slide travel	32" 815 mm

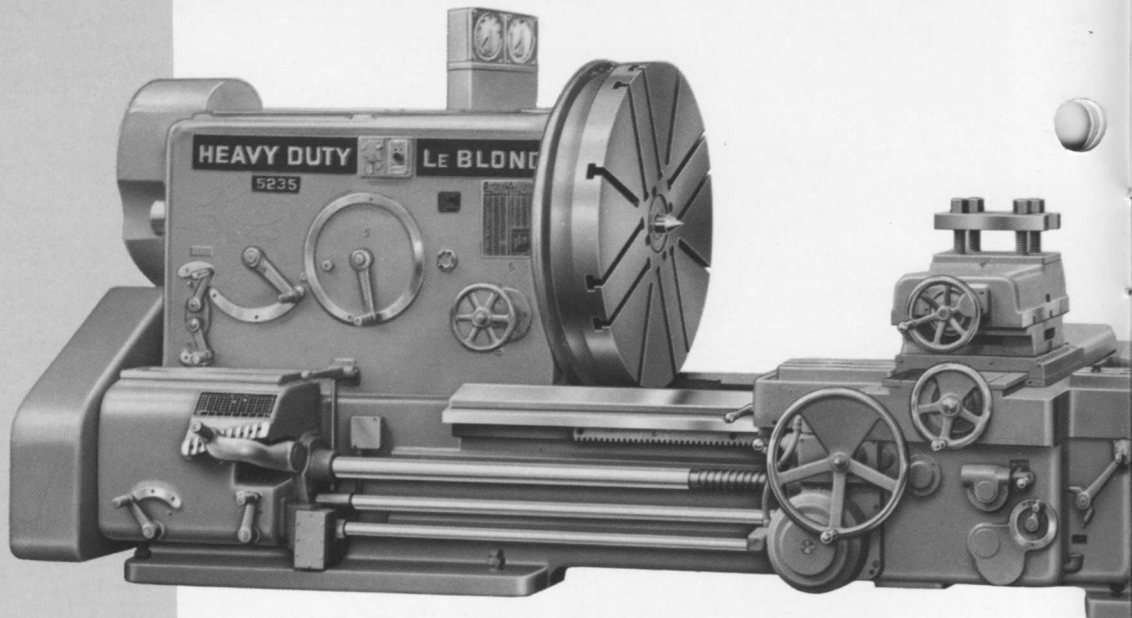

5235 NR Heavy Duty

VARIABLE SPEED DRIVE

Variable speed drive allows selection of the exact speed needed for optimum efficiency on every cut.

Spindle speeds are infinitely variable in 6 ranges, 4 of which are periphery driven. The needed range is selected by shifting one or, at most, two levers at front of headstock. Controls on left carriage wing include a speed setting potentiometer and a jog button. Duplicate jog button is at front of headstock; speed and load meters mounted on top of headstock.

Spindle is mounted on 4 anti-friction bearings with low speed, high torque gear near double, front, tapered, roller bearings to absorb heavy radial loads.

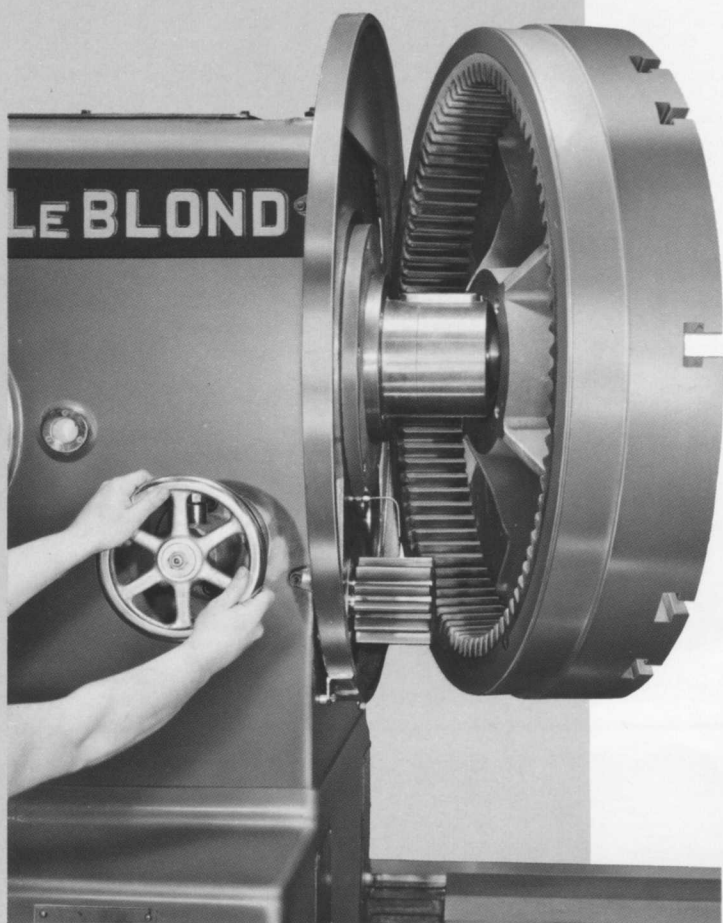

View with face plate partially removed, illustrating manner in which power is transmitted far out from work axis.

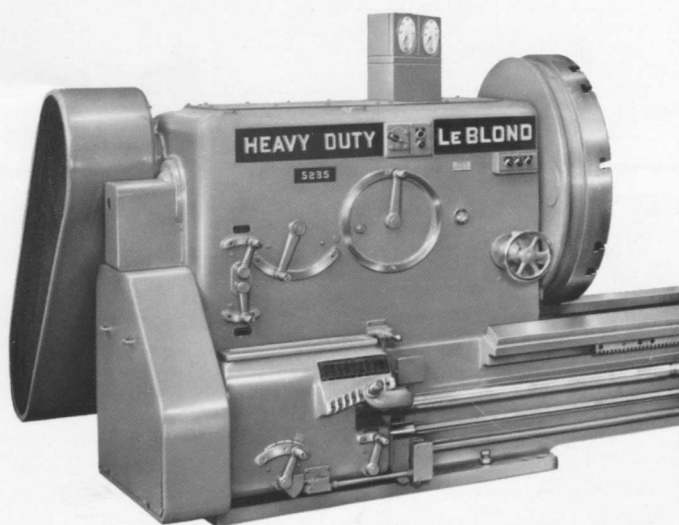

HEAVY DUTY LATHES

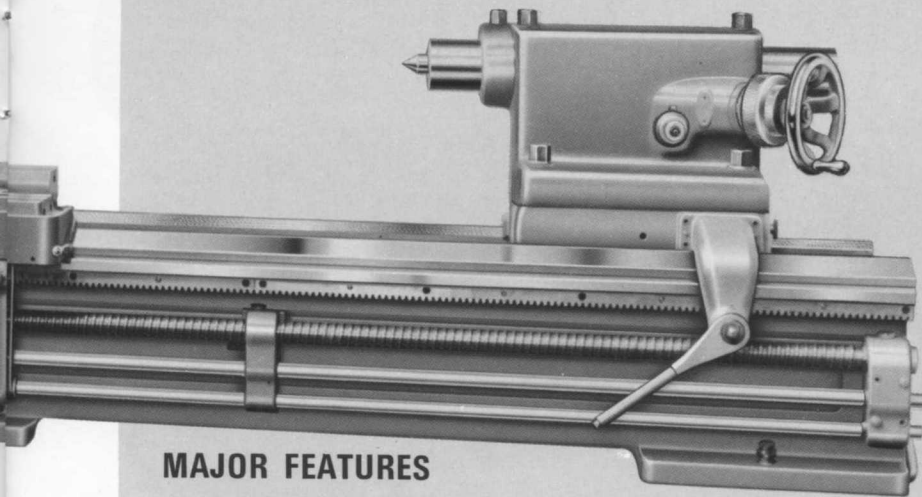

MAJOR FEATURES

- 6 speeds, including 4 through face plate drive for the ultimate in power delivery on large diameter work.
- Accurately ground spindle driven through massive spur gears. Spindle runs in 4 high capacity, precision, anti-friction bearings, largest diameter at bearing being 10 $\frac{1}{4}$ ".
- Replaceable bed ways of hardened and ground steel. Compensating vee-way design assures accurate alignment and at the same time directs cutting forces into the massive bed.
- Sturdy carriage guided on the front way only; drive from rack or leadscrew is directly below front way.
- Turcite-clad carriage bearing surfaces improve "stick-slip" characteristics and resist wear.
- Hardened and ground, replaceable, square lock cross slide ways reduce wear, provide more strength and allow more accurate movement with less maintenance.
- Six-way power rapid traverse saves tool positioning time. Top slide furnished with power angular feed and four-stud tool post assembly.
- Feed and thread changes through totally enclosed quick change box. Feeds can be reversed at the apron.
- Tailstock worm and rack locks 8" diameter spindle against

thrust, provides extra spindle travel and gives full support even when spindle is fully extended. Direct reading dial gives quick and accurate depth measurement.

STANDARD EQUIPMENT

75 HP variable speed drive • hardened and ground cross-feed screw and compensating crossfeed nut • hardened and ground replaceable steel bed ways, front and rear • large face plate driven from center or periphery • compound rest with power angular feed • four-stud tool post assembly • six-way power rapid traverse • formica-clad carriage bearing surfaces • chasing dial • drill sleeve with tang driver • tailstock mover • leadscrew supports • shear wipers • centers and necessary wrenches • two speed 12" dia. inbuilt anti-friction tailstock spindle.

OPTIONAL EQUIPMENT

Dual carriages • independent hydraulic carriage feed • tracers • heavy duty roll turning slide • taper attachment (standard or geared) • face plate jaws • chip pan • steady rest • follow rest • coolant system • single positive cross stops • metric transposing gears • inch/metric dials • 150 HP headstock • two axis digital readout system.

SPECIFICATIONS	5235 NR	5235-45 NR	5235 NR	5235-45 NR
GENERAL CAPACITY				
Swing over bed and carriage wings . . .	52 $\frac{1}{2}$ " 1330 mm	60" 1525 mm	482 12,245 mm	482 12,245 mm
Swing over cross slide	35 $\frac{1}{2}$ " 900 mm	45" 1145 mm	18 $\frac{3}{4}$ " 480 mm	18 $\frac{3}{4}$ " 480 mm
*Range of center distances	84" to 444"	84" to 444"	27 $\frac{1}{2}$ " 700 mm	27 $\frac{1}{2}$ " 700 mm
	2135 to 11,280 mm	2135 to 11,280 mm		
HEADSTOCK **				
Spindle speed ranges	6	6		
Spindle speeds, range in rpm	variable	variable		
Spindle, size of center, Morse No.	6	6		
Spindle, diameter of hole, straight	3 $\frac{1}{4}$ " 85 mm	3 $\frac{1}{4}$ " 85 mm		
BED				
Width	41 $\frac{7}{8}$ " 1065 mm	41 $\frac{7}{8}$ " 1065 mm		
CARRIAGE				
Bearing surface, square inches			482 12,245 mm	482 12,245 mm
Bridge width			18 $\frac{3}{4}$ " 480 mm	18 $\frac{3}{4}$ " 480 mm
Cross slide travel			27 $\frac{1}{2}$ " 700 mm	27 $\frac{1}{2}$ " 700 mm
FEED AND THREAD RANGE				
Feed and thread changes, number		54	54	54
Range of feeds per revolution005" to .332" .15 to 8.5 mm	.005" to .332" .15 to 8.5 mm	.005" to .332" .15 to 8.5 mm
Range of threads per inch		$\frac{1}{2}$ to 30	$\frac{1}{2}$ to 30	$\frac{1}{2}$ to 30
TAILSTOCK				
Spindle diameter		12" 305 mm	12" 305 mm	12" 305 mm
Spindle travel		18" 460 mm	18" 460 mm	18" 460 mm
MOTOR DATA				
HP up to		125	125	125
SHIPPING DATA (Basic machine with average accessories)				
Net weight, approximate		48,800 lbs.	53,800 lbs.	24,460 mm
		22,180 mm		

* Longer lengths available upon request.
 **Optional 150 HP Headstock Available.

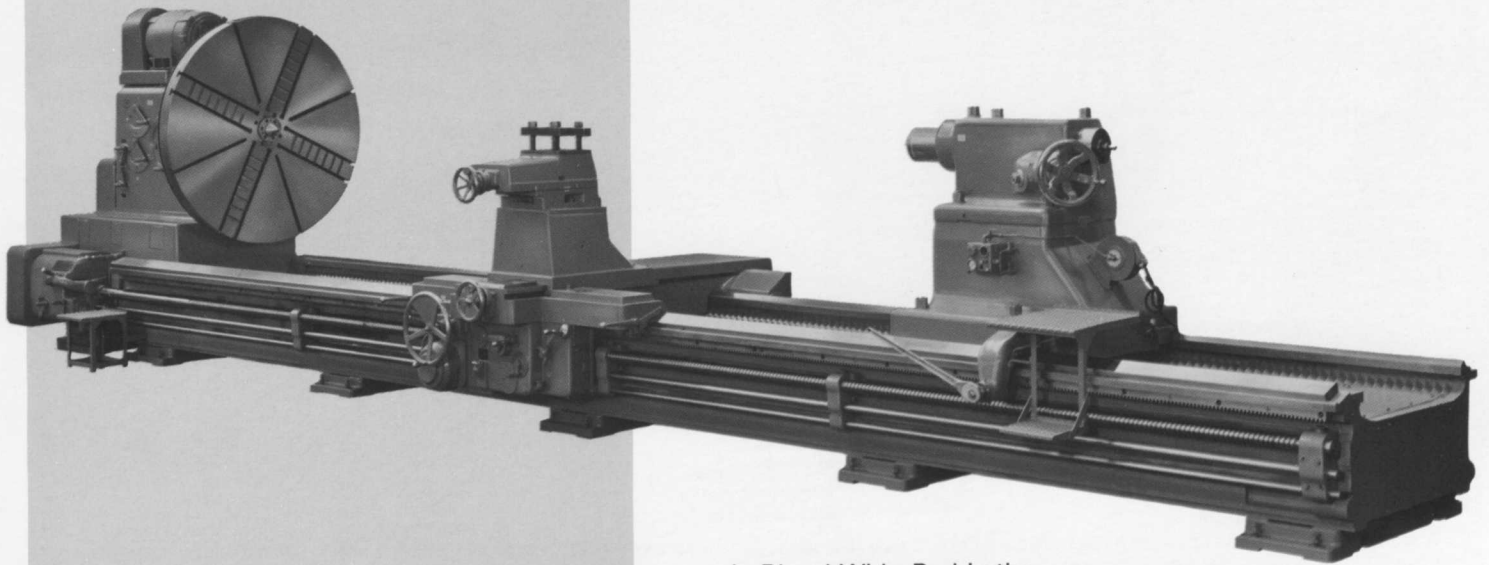

LeBlond Wide-Bed Lathe

These massive machines are for the contour turning of aerospace components, rolls or any other workpieces requiring a lathe with great swing capacity. Extreme accuracy and finish standards must be met. The complex work geometry often found in such work demands tracer controlled tooling of the highest order.

Four basic models are offered. (Larger swing capacity lathes available upon request.) Many of the basic features are much the same as in the NR Heavy Duty Lathes already described.

• **SCAN-O-MATIC TRACER.** Tool motion, length and cross, is powered by 2 hydraulic motors, controlled through a single valve. This tracer will radius turn up to 180° as a continuous cut, a requirement when work with particularly complex geometry must be machined. Attached to the rear of the 60" wide bed is the special template carrier, necessary in the handling of extraordinarily large components.

Headstock View

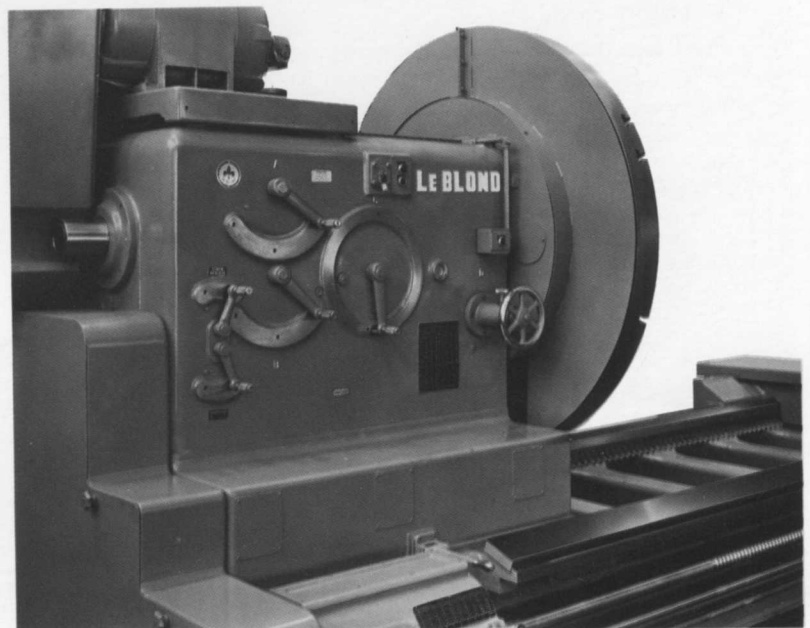

HEAVY DUTY LATHES



LeBlond Wide-Bed Lathe

SPECIFICATIONS	6642	7552	8462	9372	10484	10490	120/190
GENERAL CAPACITY Swing over bed and carriage wings Swing over cross slide Range of center distances†	66" 1680 mm 42" 1065 mm 120"-858" 3050-21,795 mm	75" 1905 mm 52" 1320 mm 120"-858" 3050-21,795 mm	84" 2135 mm 62" 1575 mm 120"-858" 3050-21,795 mm	93" 2360 mm 72" 1830 mm 120"-858" 3050-21,795 mm	104" 2640 mm 84" 2135 mm 120"-858" 3050-21,795 mm	104" 2640 mm 90" 2285 mm 120"-858" 3050-21,795 mm	120" 3050 mm 109" 2770 mm 120"-858" 3050-21,795 mm
HEADSTOCK Spindle speed ranges Spindle speeds, rpm, all models Spindle, size of center, Morse No. Spindle, hole diameter, straight	6 6 3¼" 85 mm	6 6 3¼" 85 mm	6 6 3¼" 85 mm	6 6 3¼" 85 mm	6 6 3¼" 85 mm	6 6 3¼" 85 mm	6 6 3¼" 85 mm
BED Width	60" 1525 mm	60" 1525 mm	60" 1525 mm	60" 1525 mm	60" 1525 mm	60" 1525 mm	60" 1525 mm
CARRIAGE Bearing surfaces, square inches Bridge width Cross slide travel	620 20½" 520 mm 42½" 1080 mm	620 20½" 520 mm 42½" 1080 mm	620 20½" 520 mm 42½" 1080 mm	620 20½" 520 mm 42½" 1080 mm	620 20½" 520 mm 42½" 1080 mm	620 20½" 520 mm 42½" 1080 mm	620 20½" 520 mm 42½" 1080 mm
FEED AND THREAD RANGE Number of changes Feed range per rev., all models Range of threads per inch	54 ½ to 30	54 ½ to 30	54 ½ to 30	54 ½ to 30	54 ½ to 30	54 ½ to 30	54 ½ to 30
TAILSTOCK Spindle diameter* Spindle travel	12" 305 mm 18" 460 mm	12" 305 mm 18" 460 mm	12" 305 mm 18" 460 mm	12" 305 mm 18" 460 mm	12" 305 mm 18" 460 mm	12" 305 mm 18" 460 mm	12" 305 mm 18" 460 mm
MOTOR DATA Max. hp	125**	125**	125**	125**	125**	125**	125**
SHIPPING DATA (Basic machine with average accessories) Net weight, lbs. approx.	64,000 29,090 Kg	67,000 30,455 Kg	71,000 32,275 Kg	75,000 34,090 Kg	83,000 37,730 Kg	85,000 38,635 Kg	92,000 41,820 Kg

† Longer lengths available upon request.

* 13" (330 mm) optional.

**150 H.P. available (4 spindle speed ranges) providing as much as 10 H.P. per rpm at the spindle in low range.



19" Tape-Turn Regal

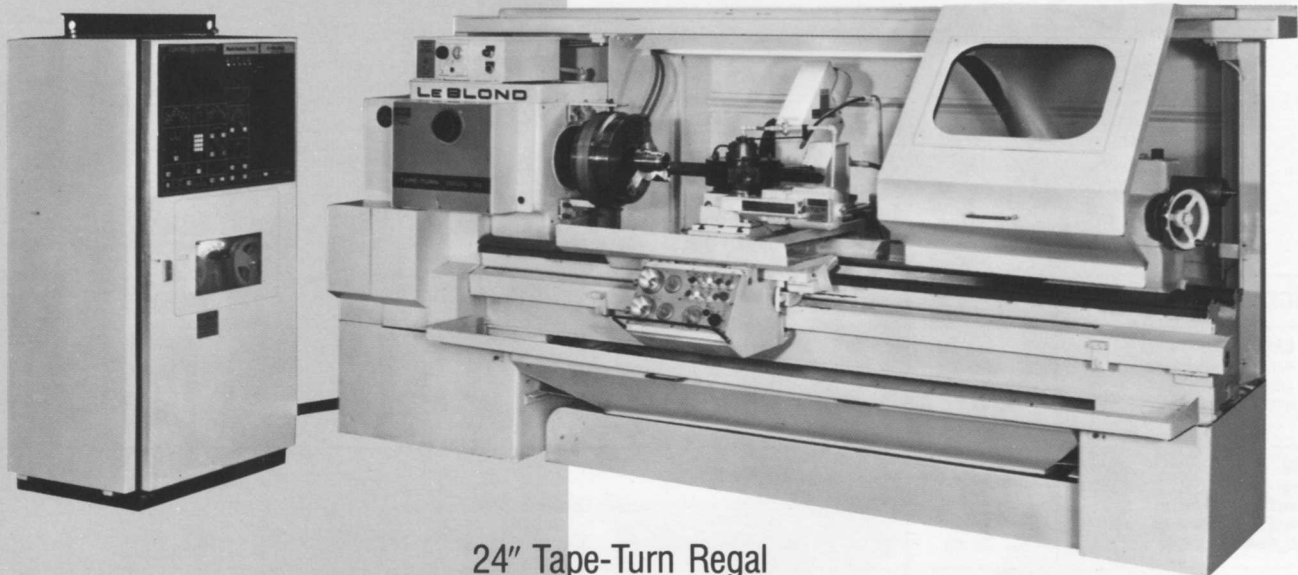

24" Tape-Turn Regal



24" Tape-Turn Regal—5 1/4" Thru-Spindle

NC LATHES

The Tape-Turn Regal product line allows any metal working shop, regardless of size, to make NC turning one of its most profitable operations. Because of their dependability and low cost, justification and quick pay back are easier to achieve than ever before. These machines incorporate more proven design features than any other NC lathe.

MODELS

The Tape Turn Regal is available in two (2) standard model sizes—19", & 24". Each model size includes a package of popular machine and control options as standard features. This innovative package concept enables LeBlond to buy in quantity and intelligently plan market and production needs. The end result—lower cost and simpler to purchase machine tools.

19" TAPE TURN REGAL

The 19" Tape Turn Regal incorporates the GE 1050 HL microprocessor CNC with distributed-processing. This compact control is totally integrated with the machine and features powerful on-board programming capabilities. The highly versatile 19" Tape Turn Regal has the following standard features and equipment:

STANDARD FEATURES

- 12" 3-jaw manual chuck • GE 1050 HL totally integrated control • 4 position—8 tool turning/boring turret • Turret index and spindle speed selections by CNC

OPTIONAL FEATURES

- 12" 3-jaw air operated chucks • Floor mounted chip conveyor • Coolant distributor for power turret • Manual tool change post • Steady rests • Coolant distributor for turret.

1050 HL CONTROL FEATURES

- Programmable control interface (PCI) • Full editing • Diameter and decimal point programming • 18 pairs of tool offsets and tool data files • Diagnos-

- tics • 7 digit universal command readout • 4 digit sequence number readout • 2 digit message readout • 34 feet of part program storage • 9 single block multipass canned cycles • Recall subroutines • Control optional features: Simplified programming package (work surface programming, simplified contour programming, countour cycle generator), additional part program storage, data input/output peripherals.

24" MODEL OPTIONS

The 24" Tape Turn Regal is the workhorse of the Tape Turn Regal Line. It is available in two (2) models—the Standard and the rugged 5¼" Thru-Spindle CNC models. Each includes the following features and equipment:

STANDARD 24" TAPE TURN REGAL

- 12" 3-jaw air operated chuck • GE 1050T PCI control • 4 position—8 tool turning/boring turret • CNC controlled turret index and spindle

5¼" THRU-SPINDLE TAPE TURN REGAL

- 15" 3-jaw manual chuck with 5½" bore chuck • GE 1050T PCI control • 5¼" Thru-bore spindle • 4 position—8 tool turning/boring turret • Turret index and spindle speed selections by CNC

OPTIONAL FEATURES

- 6 station front turret • 6 station rear turret • Floor mounted chip conveyor • Steady rests • Thru-hole power chucks

1050T PCI CONTROL FEATURES

- 40' tape storage • 32 character readout (expandable) • Complete editing • Diagnostics • Tape punch interface • 5¼" diameter tape reels • Control optional features: Tool nose radius compensation (work surface programming), parametric subroutines, canned cycles, tool inspection and retrace, additional part program storage, and 256 character readout.

TAPE TURN REGAL BASIC FEATURES

All 19" and 24" Tape Turn Regals include the following basic equipment and standard features: Hardened and ground steel bedways • Rear chip guard, chip pan and sliding front cover • Coolant pump and piping • Worklight • Heavy duty tailstock; worm and rack design • Straight and tape threading capability • Full manual operating capability • Full NC capability from tape or MDI

SPECIFICATIONS—TAPE TURN REGAL	19"		24"		24" 5¼" Thru-Spindle	
GENERAL						
Swing over bed and carriage wings	19"	485 mm	26"	660 mm	26"	660 mm
Swing over cross slide	12"	305 mm	14"	355 mm	14"	355 mm
Distance between centers	54"	1375 mm	72"	1830 mm	72"	1830 mm
HEADSTOCK						
Spindle thru-hole or bore	3½"	90 mm	3½"	90 mm	5¼"	130 mm
Spindle speeds, number	12		24		24	
Speed selection	Servo-Shift		Servo-Shift		Manual	
Spindle nose, type	L-2		8" A-1		11" A-1	
TAILSTOCK						
Spindle diameter	3½"	80 mm	3½"	90 mm	3½"	90 mm
Spindle travel	10½"	270 mm	11"	280 mm	11"	280 mm
CARRIAGE & SLIDES						
Length on bed	21"	535 mm	26"	660 mm	26"	660 mm
Cross slide travel	11"	280 mm	17"	430 mm	17"	430 mm
Bridge Width	7¾"	200 mm	9"	230 mm	9"	230 mm
FEED						
Rapid traverse rate	150 IPM	3.81 m/min	250 IPM	6.35 m/min	250 IPM	6.35 m/min
BED						
Width	14¾"	365 mm	17"	430 mm	17"	430 mm
Depth	11½"	290 mm	14½"	370 mm	14½"	370 mm
MOTOR DATA						
Motor	10 HP-15 min. 7½ HP Cont.		20/15 HP Duty Cycle		20/10 HP Duty Cycle	
SHIPPING DATA						
Floor space	113" x 54¼"	2870 mm x 1380 mm	117" x 167"	2970 mm x 4240 mm	117" x 167"	2970 mm x 4240 mm
Net shipping weight, average	6300 lbs.	2865 kg	9,600 lbs.	4360 kg	10,100 lbs.	4590 kg

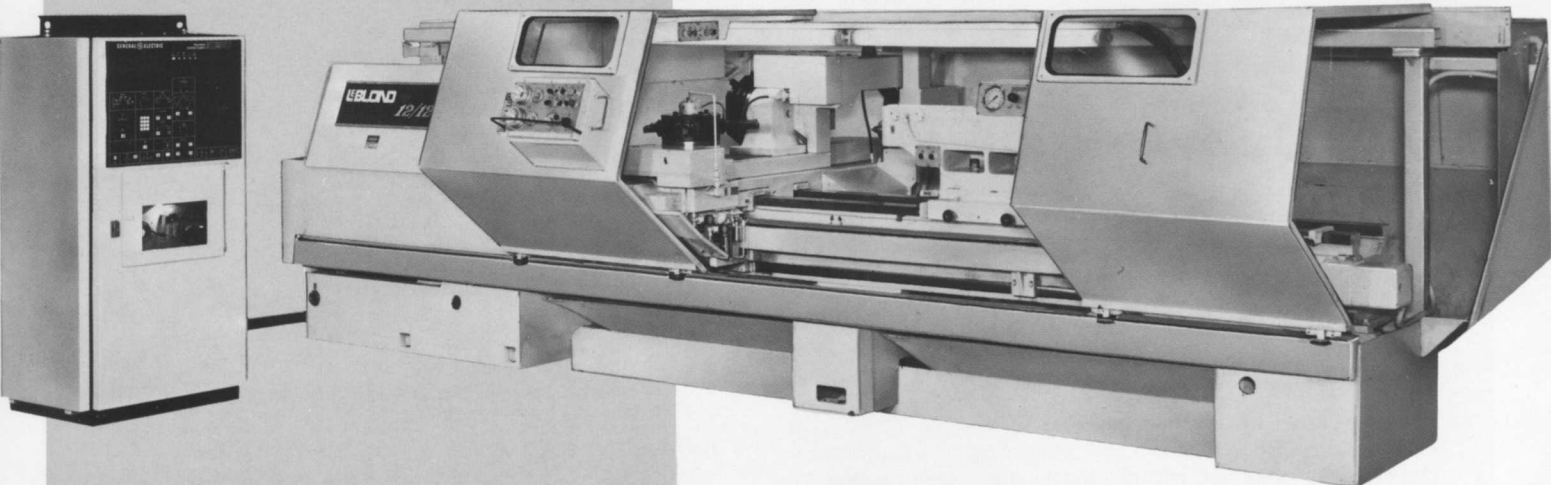

108" Long Bed Model

MARK II UNIVERSAL TURNING CENTER

- The MARK II product line offers unequalled, full featured, turning capability for the investment dollar. Whether the job is chucking, bar work, or shafts up to 108" long, the MARK II can profitably increase your production.

MODELS

- The MARK II is available in three (3) standard model sizes: Chucker (tailstock optional), 60", and 108" turning lengths. Each model size includes a package of standard machine and control features.

MAJOR FEATURES

HEADSTOCK

- The MARK II headstock is a powerful unit designed to accommodate the full power of the 30 horsepower spindle drive. Its three geared ranges are actuated by hydraulic clutches and all are hardened and precision ground. Speed variation is provided by a proven, reliable, aircraft quality transmission which performs the same function as a DC drive.

TAILSTOCK

- The MARK II tailstock provides increased rigidity with a sturdy two piece construction and a large $4\frac{1}{8}$ inch diameter quill. Powered tailstock quill operation is standard with programmable spindle advance and retract optional. The fully automatic interlocked quill is driven by an Acme screw, and has a spindle thrust rating of 3,700 lbs. at 2500 RPM. Even if there is a complete loss of hydraulic pressure or electrical power, the quill can not back away from the workpiece.

TOOLING

- The MARK II offers tooling capacity unparalleled in its class. The standard tooling configuration offers 6 ID tools in a hexagonal horizontal front turret, and 6 OD tools in a vertical rear turret for 12 tools total. An optional 12 tool turret replaces the 6 tool vertical rear turret to increase the total to 18 tools. The turrets employ LeBlond's unique indexing mechanism which allows accurate indexing of the turret without separating couplings or exposing them to dirt and coolant.

BED DESIGN

- The MARK II bed is a unique I-Delta, tri-way design combining the best of the slant bed and flat bed configurations. The three way bed provides unequalled rigidity and stability. Exceptional chip and coolant flow results from this unique bed concept. To reduce downtime for chip removal, a chip conveyor is standard.

OPERATOR CONTROL STATION

- An Operator Control Station is provided on the front shield for convenience during set-up or when operating the machine manually. The Operator Control Station features LeBlond's patented Powered Differential Resolvers (PDR) for ultimate control of the X and Z axes during manual operation.

AXIS DRIVES

- High performance DC axis drives provide smooth, quick response coupled with excellent reliability. Maximum traverse rate is 400 inches per minute for each axis. These powerful axis drives contribute to the MARK II's overall ability to handle heavy work not normally associated with a machine in the 30 horsepower class.

NC LATHES

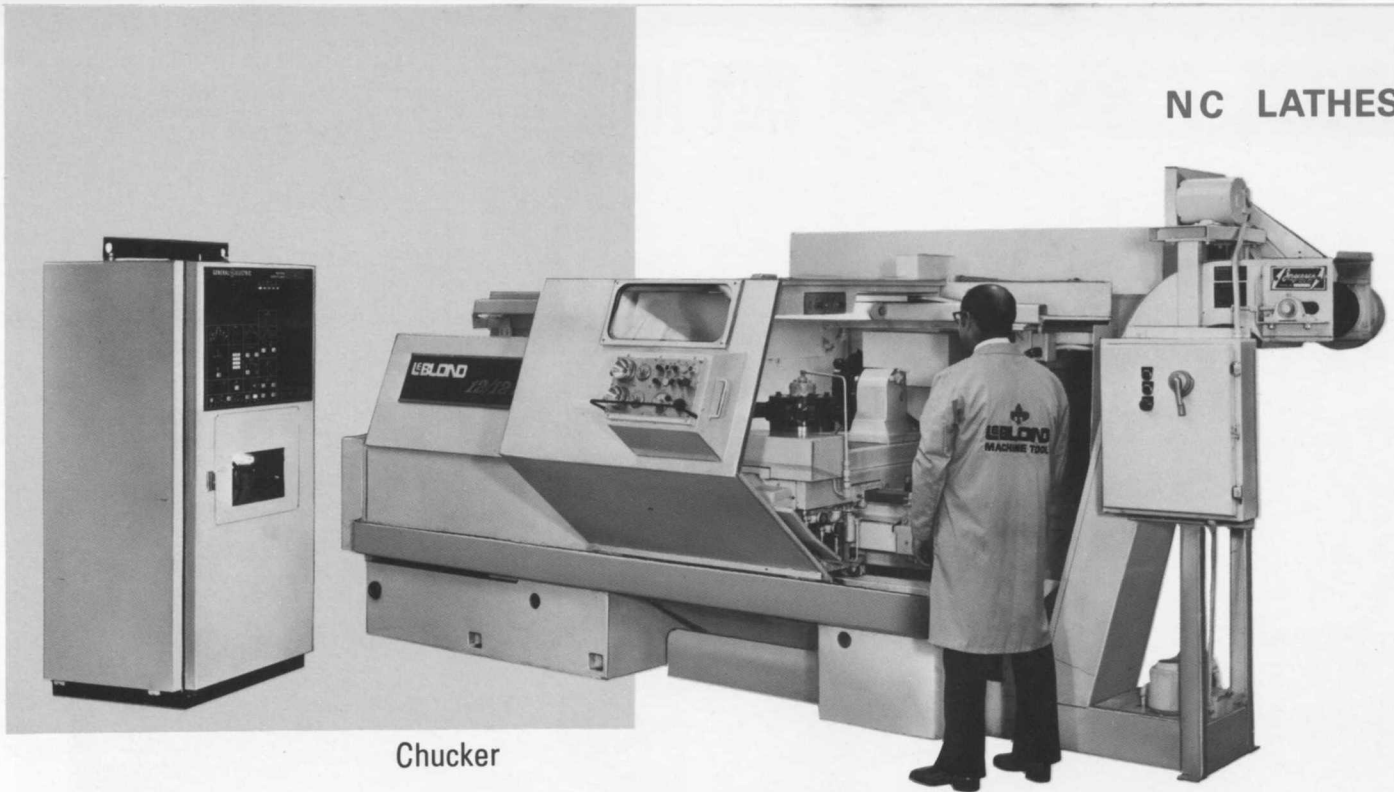

Chucker

SPECIFICATIONS—12/12 MARK II

General	Inches	mm
Swing over bed and carriage	20	510
Swing over cross slide	12	305
Chucker stroke	16	762
Turning Lengths:		
Chucker with tailstock option	12	305
Universal	60	1524
Long Bed	108	2743

Headstock		
Clutch ranges by NC	3	
Spindle speed ranges, Standard	60-2500 or 30-1500 RPM	
	Optional	60-3000 RPM
Spindle nose, A-1	8	205
Hole thru spindle	3 ¹ / ₁₆	77.8
Motor HP continuous duty	30	
Number of speeds	1 RPM increments	

Carriage & Slide		
Horizontal front turret, size	10	254
Number of tools	6	
Number of index positions	12	
Vertical rear turret		
Number of tools	Std. 6	
	Opt. 12	
Number of index positions	12	
Turret couplings, diameter	10	254
Cross travel, total	19 ³ / ₈	492
Traverse rate, max. both axes	400 IPM	10160 mm/min.
Feedrate, infinitely variable	0-200 IPM	0-5080 mm/min.

Tailstock	Inches	mm
Length on bed	18 ¹ / ₄	464
Quill diameter	4 ¹ / ₈	105
Quill type	In-built revolving center	
Quill travel	9	229
Quill operation	Pushbutton actuated	
Center size	# 4 Morse	

Chucks		
Manual scroll and independent,		(305mm)
and air/hydraulic actuated	12" and 15"	(381mm)

STANDARD EQUIPMENT

- Hardened and ground geared headstock with hardened and ground alloy steel ways.
- Unique I-Delta tri-way bed.
- Hydraulically powered tailstock quill.
- Convenient operator control station with—Powered Differential Resolvers (PDR) for full manual control.
- High performance DC electric feed drives.
- Chip shield, dual coolant pumps, and piping.
- Chip conveyor with reversing control.
- Worklight.
- General Electric 1050T microprocessor computer numerical controller (CNC) with Programmable Control Interface (PCI); 32 character readout; 108 ft. tape storage (expandable); complete program editing; tape punch interface; 5¹/₄" tape reels; 30 hours memory protection, and 28K memory.
- Machine and control diagnostics.



TAPE-TURN IIC



TAPE-TURN IIC/S

MAJOR FEATURES

- This machine is offered in two basic forms. Tape-Turn II C is ideal for chucking work, while Tape-Turn II C/S can handle chucking or shaft work.
- Low initial investment for Tape-Turn II opens the possibility to create an N/C turning center, consisting of two lathes under the supervision of one operator.
- All LeBlond Tape-Turn lathes can earn dramatic savings in setup time, reduced number of operations, floor to floor time, tooling costs, measuring time, ratio of machining to non-cutting time, operator learning time, operator efficiency, inventory space and taxes.

Precision feed screws—length and cross—with preloaded, recirculating ball bearing unit and automatic compensation

- hardened and ground steel bed ways, front and rear •

hardened and ground cross slide ways • pump and piping • chip pan • coolant shield • centers and necessary wrenches • CNC controls • LeBlond magnetic control panel and necessary cabling • one-year warranty on complete machine including all electrical controls. • High performance electric servos on length and cross axes.

12-position hexagonal turret • 40 hp, SCR 1.6 constant hp DC motor, 90 speed points • Rear turret (optional).

SPECIFICATIONS—Tape-Turn II	IIC	IIC/S
GENERAL CAPACITY		
Swing over bed and carriage wings	30" 760 mm	30" 760 mm
Swing over cross slide	20" 510 mm	20" 510 mm
Basic center distance	42" stroke 1070 mm	*48" 1220 mm
HEADSTOCK		
Spindle speeds, number	1080	1080
Spindle speeds, range in rpm	9 to 1194	9 to 1194
Spindle, size of center, Morse No.	4	4
Spindle nose, taper key drive, size	11"-A1	11"-A1
BED		
Width	20" 510 mm	20" 510 mm
CARRIAGE & SLIDES		
Length on ways	40" 1020 mm	40" 1020 mm
Power turret, tape commanded, positions	12	12
Curvic coupling, diameter	11" 280 mm	11" 280 mm
FEEDS		
Length or cross, in. per min05 to 300 in/min	.05 to 300 in/min
Increment of feeds, in. per min	1.3 to 7620 mm/min .01/.25 mm	1.3 to 7620 mm/min .01/.25 mm
TAILSTOCK		
Spindle diameter		4½" 115 mm
Spindle travel		12½" 320 mm
MOTOR DATA:		
HP and rpm (1.6 constant HP)	40 HP 280/1750/2800	40 HP 280/1750/2800

*Also available with 96" and 144" centers capacity.

LEBLOND TAPE-TURN I

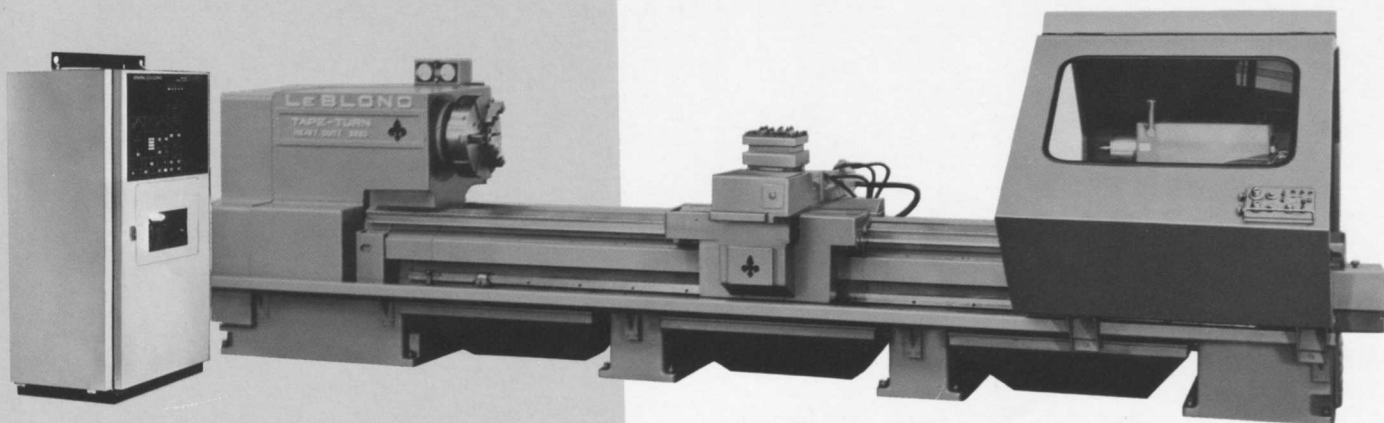

TAPE-TURN I 3220 NF



TAPE-TURN I 4625 NK



TAPE-TURN I 15" Hollow Spindle

NC LATHES

MAJOR FEATURES

- Tape-Turn I is the most sophisticated form of NC lathe offered by LeBlond. This is a static, solid-state, continuous path control with no relays, stepping switches or electronic tubes in its logic circuits. Data input is from an 8-channel tape.
- Control commands three modes of operation: (1) straight lines, parallel to Z or X axes or at any angle to them; (2) clockwise or counter-clockwise circular arcs up to 10" radius, including compound curves blended to many arcs; and (3) dwells for speed changing, turret indexing, corner cleanup, etc.
- Tape also commands feeds, speeds, tool turret indexing and miscellaneous functions such as planned stops for checking, coolant on-off and feed gear range. Thread chasing may be programmed into the cycle as required.
- The N/C control unit has a repeat electrical positioning accuracy of $\pm 0.000060"$ with a system feedback resolution of $0.000050"$. Zero offset is provided over the full range of travel. Duplicated control functions on console permit operator to override the tape manually.
- Standard, insert-type tooling is accepted by the 4 available turret tool holders. Repeatability of turret position is ± 3 seconds of angle.

STANDARD EQUIPMENT

- Precision feed screws—length and cross—with preloaded, recirculating ball bearing unit and automatic compensation
- hardened and ground steel bed ways, front and rear
- hardened and ground cross slide ways
- chip pan
- centers and necessary wrenches
- CNC control
- one-year warranty on complete machine including all electrical controls
- coolant shield
- Rear turret (OPTIONAL)
- 12 position hexagonal turret (OPTIONAL)
- Coolant pump and piping (OPTIONAL)
- High performance electric servos on length and cross axis.

SPECIFICATIONS—TAPE-TURN I	3220 NF	4625 NK	5029 NK	4625 NK HOLLOW SPINDLE	5029 NK HOLLOW SPINDLE
GENERAL CAPACITY					
Swing over bed and carriage wings	32" 810 mm	46" 1170 mm	50" 1270 mm	46" 1170 mm	50" 1270 mm
Swing over cross slide	20" 510 mm	25" 635 mm	29" 740 mm	25" 635 mm	29" 740 mm
Basic center distance	72" 1830 mm	60" 1525 mm	60" 1525 mm	60" 1525 mm	60" 1525 mm
HEADSTOCK					
Spindle speeds, number	540	540	540	180	180
Spindle speeds, range in rpm	7 to 1075	3 to 701	3 to 70	10 to 850	10 to 850
Spindle, size of center, Morse No.	5	6	6	—	—
Spindle nose, std. taper key drive, size	11" A-1	15" A-1	15" A-1	19" Flange	19" Flange
Spindle, thru hole	4 $\frac{3}{16}$ " 110 mm	7 $\frac{1}{16}$ " 195 mm	7 $\frac{1}{16}$ " 195 mm	15" 380 mm	15" 380 mm
BED					
Width	24 $\frac{1}{2}$ " 620 mm	34" 865 mm	34" 865 mm	34" 865 mm	34" 865 mm
CARRIAGE AND TURRET SLIDE					
Carriage, length on ways	40" 1015 mm	46 $\frac{3}{4}$ " 1190 mm	46 $\frac{3}{4}$ " 1190 mm	46 $\frac{3}{4}$ " 1190 mm	46 $\frac{3}{4}$ " 1190 mm
Turret slide travel	22 $\frac{1}{2}$ " 570 mm	28" 710 mm	28" 710 mm	28" 710 mm	28" 710 mm
Turret, standard	11" Square 280 mm	15" Square 380 mm	15" Square 380 mm	15" Square 380 mm	15" Square 380 mm
FEEDS					
Range of feeds, in. per min.	.05 to 250 1.5 to 6350 mm	.1 to 150 2.5 to 3810 mm	.1 to 150 2.5 to 3810 mm	.1 to 150 2.5 to 3810 mm	.1 to 150 2.5 to 3810 mm
TAILSTOCK					
Spindle diameter	6" 150 mm	8" 205 mm	8" 205 mm	8" 205 mm	8" 205 mm
Spindle travel	15" 380 mm	18" 460 mm	18" 460 mm	18" 460 mm	18" 460 mm
MOTOR DATA					
HP up to	50	75	75	75	75

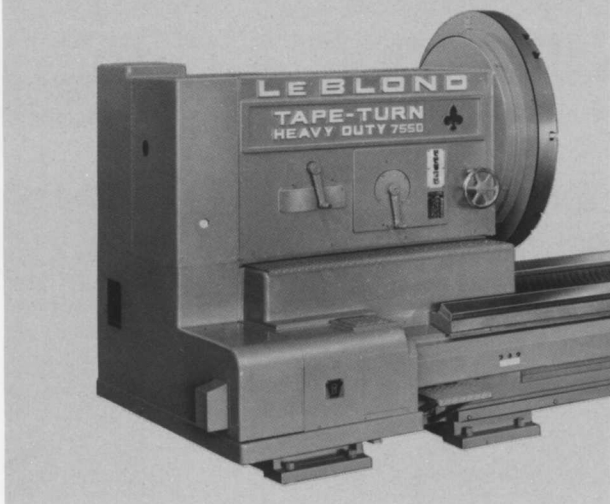

TAPE-TURN I 7550 WB
with Optional 13" Power Tailstock

This massive NC lathe is built to handle the large parts that require an NC lathe with increased swing over the bed. The Tape Turn I Wide Bed has the same major features as the Heavy Duty NC Lathes described on the previous page.

Four models are offered ranging from 66" to 93" swing over the bed and carriage wings.

STANDARD EQUIPMENT

Precision feed screws—length and cross—with preloaded recirculating ball bearing unit and automatic compensation • hardened and ground steel bed ways, front and rear • hardened and ground cross slide ways • chip pan • centers and necessary wrenches • CNC control • one year warranty on complete machine including all electrical controls

- coolant pump and piping (OPTIONAL)
- High performance electric servos on length and cross axis.

SPECIFICATIONS—TAPE-TURN I	6640 WB	7550 WB	8460 WB	9370 WB
GENERAL CAPACITY				
Swing over bed and carriage wings	66" 1680 mm	75" 1905 mm	84" 2135 mm	93" 2360 mm
Swing over cross slide	40" 1020 mm	50" 1270 mm	60" 1525 mm	70" 1780 mm
Basic center distance	120" 3050 mm	120" 3050 mm	120" 3050 mm	120" 3050 mm
*HEADSTOCK				
Spindle speeds, number	540	540	540	540
Spindle speeds, range in rpm94 to 300	.94 to 300	.94 to 300	.94 to 300
Spindle, size of center, Morse No.	4 1/8" dia. flange 105 mm	4 1/8" flange 105 mm	4 1/8" flange 105 mm	4 1/8" flange 105 mm
Spindle nose	Face Plate Drive	Face Plate Drive	Face Plate Drive	Face Plate Drive
BED				
Width	60" 1525 mm	60" 1525 mm	60" 1525 mm	60" 1525 mm
CARRIAGE AND TURRET SLIDE				
Carriage, length on ways	78" 1980 mm	78" 1980 mm	78" 1980 mm	78" 1980 mm
Turret, slide travel	43.5" 1105 mm	43.5" 1105 mm	43.5" 1105 mm	43.5" 1105 mm
Turret, standard	15" Square 380 mm	15" Square 380 mm	15" Square 380 mm	15" Square 380 mm
FEEDS				
Range of feeds, in. per min05 to 150 1.5 to 3810 mm	.05 to 150 1.5 to 3810 mm	.05 to 150 1.5 to 3810 mm	.05 to 150 1.5 to 3810 mm
TAILSTOCK				
Spindle diameter	12" 305 mm	12" 305 mm	12" 305 mm	12" 305 mm
Spindle travel	18" 460 mm	18" 460 mm	18" 460 mm	18" 460 mm
MOTOR DATA				
HP up to	125	125	125	125

*Optional 150 HP headstock available.

LEBLOND

JIG GRINDERS

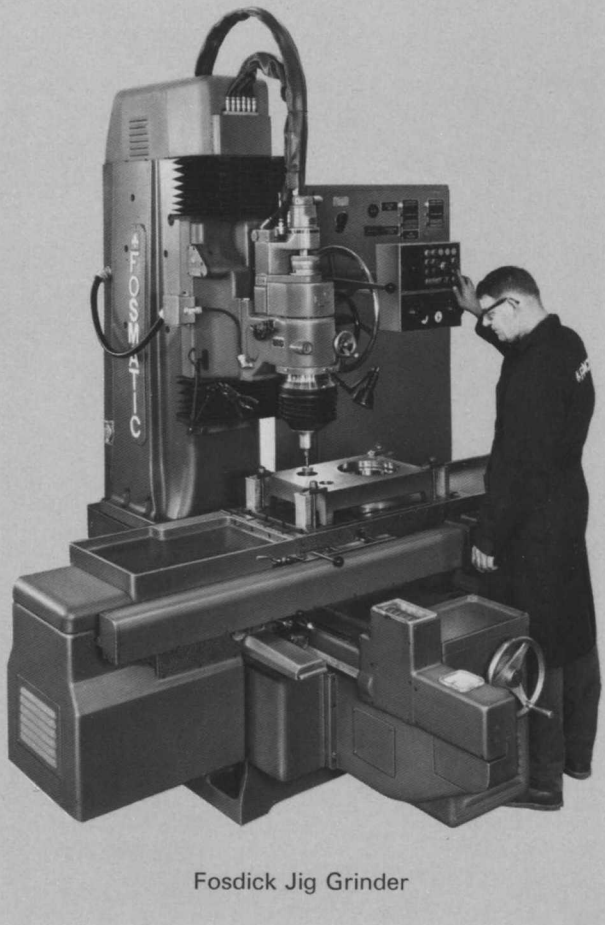

Fosdick Jig Grinder

A new degree of speed, convenience, and capacity is brought to precision grinding in the Fosdick Jig Grinders. All standard jig grinding operations and numerous production operations can be conveniently accomplished on the Fosdick and also many which were formerly known as "trick" operations. Both straight and tapered holes can be located and ground, along with contours consisting of radii and tangents or chordal surfaces. The angular and indexing device, built into the main spindle, and the slot grinding attachment permit quick, accurate grinding of any contour, regular or irregular. Chop grinding removes stock rapidly and makes contour grinding even faster.

STANDARD EQUIPMENT

Infinitely variable spindle speeds, infinitely variable spindle feed rates, contour grinding index controls, pressure regulators and gages for automatic feeds and grinding heads, automatic temperature control of spindle housing, air lubricator for automatic spindle feed, power traverse and clamp of table and saddle, dust protective guards, adjustable work light, wheel dresser, and 1/2 HP variable speed DC motor.

OPTIONAL EQUIPMENT

Two-axis numerical control, extra spindle height, power head elevation and clamp, dust exhaust system and additional grinding heads.

AVAILABLE WITH TWO POSITIONING SYSTEMS:

1. Digital Readout and Power Positioning
2. Numerical Control. Two-Axis.

SPECIFICATIONS	Model 42	Model 44	Model 56
Table working surface	42" x 18" 1065 mm x 455 mm	44" x 22" 1120 mm x 560 mm	56" x 28" 1420 mm x 710 mm
Table travel (longitudinal)	36" 915 mm	42" 1065 mm	48" 1220 mm
Saddle travel (transverse)	20" 510 mm	22" 560 mm	28" 710 mm
Table top to wheel collet	2" to 24 1/2" 50 mm to 620 mm	1" to 27 1/2" 25 mm to 700 mm	1" to 27 1/2" 25 mm to 700 mm
Column face to spindle centerline	16 1/2" 420 mm	18 1/2" 470 mm	23 3/4" 605 mm
Column throat to spindle centerline	21" 535 mm	25 1/4" 640 mm	30 1/2" 775 mm
Head travel on column	19" 485 mm	23" 585 mm	23" 585 mm
Spindle travel	3 5/8" 90 mm	3 5/8" 90 mm	3 5/8" 90 mm
Floor space, basic machine	144" x 115" 3660 mm x 2920 mm	157" x 121" 3990 mm x 3075 mm	166" x 133" 4215 mm x 3380 mm
Height overall	124" 3150 mm	124" 3150 mm	124" 3150 mm
Net weight (approx.)	11,500 lbs. 5225 Kg.	21,000 lbs. 9545 Kg.	24,000 lbs. 10,910 Kg.

Designed for Stability

- Main castings are of close-grained, high test, alloyed cast iron and are stress relieved after rough machining.
- Closely-spaced internal ribbing provides extra margin stability.
- All Ways are flat and wide, hand scraped and spotted.
- Central V-guideways, automatically compensate for wear, therefore, maintain squareness between table and saddle movements. Looseness and alignment problems are avoided by eliminating gibs.
- Unique wide spaced clamps eliminate all deflection.

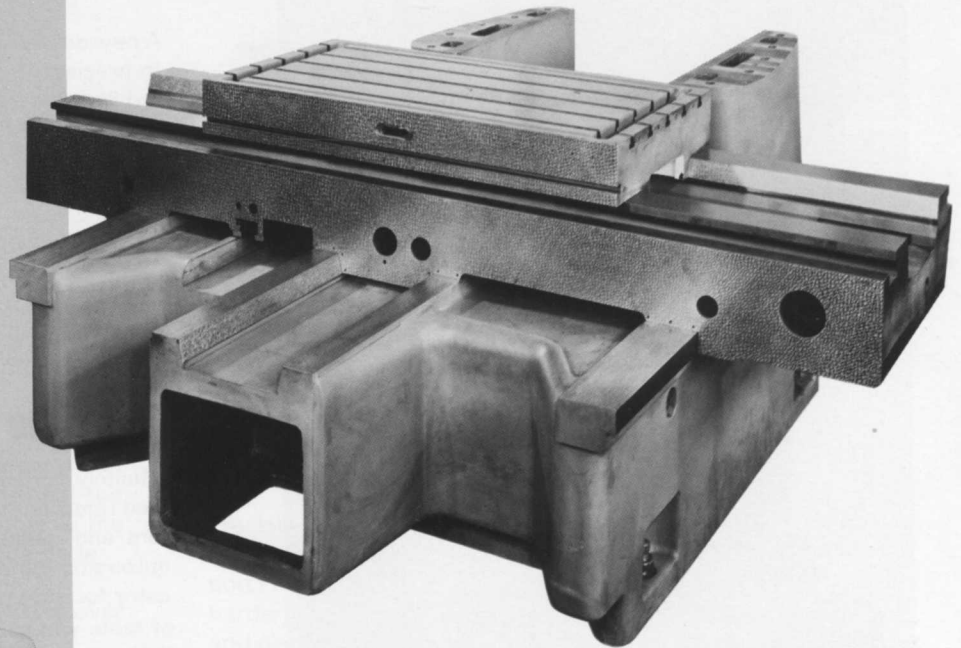

Base, Saddle, and Table



Model 56, NC Jig Borer

MAJOR FEATURES

Fosdick Jig Borers combine unequalled positioning speed and accuracy, they quickly justify themselves in any shop, whether they are used for prototype, toolroom or production work.

Fosdick is the only Jig Borer that can be "job matched" for you. This is possible because of the wide range of sizes and positioning systems that can be combined to make your new Jig Borer one of your most profit producing machines.

BUILT FOR THE MOST DEMANDING WORK

All major castings are designed for extra stability. The machine ways are flat and wide and have a means for wear compensation. The quill is furnished with recirculating linear bearings and the spindle is designed for fast, accurate tool changing.

POSITIONING SYSTEMS

Digital Readout and Power to Position allows the operator to move the table to the desired position under power, using the infinite rate control and watching his position on the digital readout. This may also be used for measuring.

Numerical Control Jig Borers equipped with NC provide owners with the ability to make the Jig Borer more productive than with any other type of control. There are two basic versions available, 2-axis and 3-axis with head height control.



Quill and Spindle

- Hardened and ground alloy steel, the quill rides in two preloaded, recirculating ball type linear bearings.
- Bearings stay at the top and bottom of the head, regardless of quill position, providing maximum support.
- Spindle is mounted in the quill in a matched set of widely spaced angular contact, preloaded Class 9 ball bearings.

SPECIFICATIONS	Model 42	Model 44	Model 56
Table working surface	42" x 18" 1065 x 455 mm	44" x 22" 1120 x 560 mm	56" x 28" 1420 x 710 mm
Table travel (longitudinal)	36" 915 mm	42" 1065 mm	48" 1220 mm
Saddle travel (transverse)	20" 510 mm	22" 560 mm	28" 710 mm
Table tee slots	(4) $\frac{9}{16}$ " 14.3 mm	(5) $\frac{9}{16}$ " 14.3 mm	(5) $\frac{11}{16}$ " 17.4 mm
Table to spindle (max.)	28½" 725 mm	33" 840 mm	33" 840 mm
Table to spindle (min.)	4" 100 mm	6" 150 mm	6" 150 mm
Column face to spindle centerline	16½" 420 mm	18½" 470 mm	18½" 470 mm
Column throat to spindle centerline	21" 535 mm	25¼" 640 mm	30½" 775 mm
Column throat to table surface	16" 405 mm	22" 560 mm	22" 560 mm
Head travel on column	15½" 395 mm	18" 455 mm	18" 455 mm
Spindle travel	9" 230 mm	9" 230 mm	9" 230 mm
Quill diameter	4⅞" 125 mm	4⅞" 125 mm	4⅞" 125 mm
Max. taper, spindle adapter (Morse)	#4	#4	#4
Speeds	← 10-2000 R.P.M. →		
Feeds	← .01 to 30 I.P.M. Rapid Traverse 150 I.P.M. →		
Spindle drive, D.C.	5 H.P.	5 H.P.	5 H.P.
Floor space, basic machine	144" x 115" 3660 x 2920 mm	157" x 121" 3990 x 3075 mm	166" x 133" 4215 x 3380 mm
Height, overall	130" 3300 mm	130" 3300 mm	130" 3300 mm
Net weight (approx.)	13,500 lbs. 6135 Kg	24,000 lbs. 10,910 Kg	26,000 lbs. 118,200 Kg

LeBlond Direct Sales Offices

CHICAGO, ILLINOIS
LeBlond
430 Milwaukee Ave.
Lincolnshire, Illinois 60069
Phone: 312 634-1820

CINCINNATI OHIO
LeBlond
Madison & Edwards Roads
Cincinnati, Ohio 45208
Phone 513 351-1700

CLEVELAND, OHIO 44122
LeBlond
28790 Chagrin Blvd.
Phone: 216 464-2266

DETROIT, MICHIGAN
LeBlond
21411 Civic Center Drive
Suite 204
Southfield, Michigan 48076
Phone: 313 353-0366

LOS ANGELES, CALIFORNIA
LeBlond
4555 Pacific Blvd.
Vernon, California 90058
Phone: 213 589-5055

MILWAUKEE, WISCONSIN
LeBlond
430 Milwaukee Ave.
Lincolnshire, Illinois 60069
Phone: 414 332-7500

NEW YORK, NEW YORK
LeBlond
1620 Route 22 East
Union, New Jersey 07083
Phone: 201 687-7500

Domestic Distributors

ATLANTA, GEORGIA 30092
R. O. Deaderick Co., Inc.
P. O. Box 49331
45 Technology Park
Phone: 404 448-2793

BALTIMORE, MARYLAND 21204
Gundersen Machinery Inc.
P. O. Box 9867
Phone: 301 296-8820

BIRMINGHAM, ALABAMA 35959
R. O. Deaderick Co., Inc.
Route 2, Box 217
Phone: 205 526-8334

BOSTON, MASSACHUSETTS 01949
R. A. Hebert Machine Tool Co., Inc.
212 South Main Street
Phone: 617 777-1313

CEDAR RAPIDS, IOWA 52404
The Satterlee Co.
280 Prospect Place S.W.
Phone: 319 366-7778

COLUMBIA, SOUTH CAROLINA 29169
Wrenn Machine Tools Inc.
P. O. Box 525, Interstate 26
Phone: 803 794-4100

DALLAS, TEXAS 75245
C. J. Harter & Son Machinery Inc.
Level A Exchange Park
P. O. Box 45308
Phone: 214 357-1501

DENVER, COLORADO 80204
Duboc-Lane & Monckton Inc.
637 Osage Street
Phone: 303 623-1261

DULUTH, MINNESOTA 55806
The Satterlee Company
2202 West First Street
P. O. Box 6417
Phone: 218 727-8454

ERIE, PENNSYLVANIA 16415
Barney Machinery Company
6816 W. Haskel
Phone: 814 474-3366

FT. LAUDERDALE, FLORIDA 33334
R. O. Deaderick Co., Inc.
4066 N.E. Fifth Avenue
Phone: 305 563-5723

GRAND RAPIDS, MICHIGAN 49510
Wing & Jabaay, Inc.
P. O. Box 7265
Phone: 616 241-3474

HARTFORD, CONNECTICUT 06101
The H-B Machinery Co.
P. O. Box 445
77 Fishfy Street
Phone: 203 249-7679

HONOLULU, HAWAII 96812
Berkley Engineering & Equipment Co. Inc.
Post Office Box 3856
Phone: 808 538-1921

HOUSTON, TEXAS 77003
C. J. Harter & Son Machinery Inc.
3838 Navigation Boulevard
Phone: 713 227-7221

INDIANAPOLIS, INDIANA 46203
W. W. Siegrist Machinery Co., Inc.
1139 Shelby Street
Phone: 317 632-3468

JACKSONVILLE, FLORIDA 32205
R. O. Deaderick Co., Inc.
P. O. Box 37139
Phone: 904 772-1103

KANSAS CITY, KANSAS 66215
Ernst-Eichman Machinery Corp.
15541 West 110th. Street
Phone: 913 492-2770

KNOXVILLE, TENNESSEE 37901
R. O. Deaderick Co., Inc.
423 Depot Avenue N. W.
P. O. Box 1949
Phone: 615 524-2537

LOUISVILLE, KENTUCKY 40213
Advance Machinery Company, Inc.
4525 Poplar Level Road
Louisville, Kentucky
Phone: 502 969-3126

MINNEAPOLIS, MINNESOTA 55404
The Satterlee Company
2200 East Franklin Avenue
Phone: 612 370-2511

MOLINE, ILLINOIS 61265
DeLeon-Thompson Company
5308 - 23rd. Ave.
Phone: 309 762-4418

NASHVILLE, TENNESSEE 37215
R. O. Deaderick Co., Inc.
P. O. Box 15604
Phone: 615 383-8949

NEW ORLEANS, LOUISIANA 70002
Richards Machinery & Supply Co.
2900 Veterans Blvd.
Suite 215
Phone: 504 837-9404

OMAHA, NEBRASKA 68127
Ernst-Eichman Machinery Corp.
8909 "H" Street
Phone: 402 339-3930

PHILADELPHIA, PA. 19154
Lemuel R. Lance, Inc.
Philadelphia Industrial Park
10400 Drummond Road
Phone: 215 824-3400

PHOENIX, ARIZONA 85501
DiEugenio Tool Center, Inc.
1120 S. Black Canyon Hwy.
Phone: 602 258-8364

PITTSBURGH, PENNSYLVANIA 15220
Barney Machinery Company
1002 Greentree Road
Phone: 412 922-1207

PORTLAND, OREGON 97219
Buckner-Weatherby Co., Inc.
10175 S. W. Barbur Blvd.
Suite 300B
Phone: 503 246-8278

RICHMOND, VIRGINIA 23224
Wrenn Machine Tools, Inc.
2420 Hull Street
Phone: 804 232-4355

ROCHESTER, NEW YORK 14564
R. H. Britton Machinery Sales, Inc.
7500 Victor Mendon Road
P. O. Box 0
Phone: 716 924-9335

SALT LAKE CITY, UTAH 84115
J. M. Grisley Machine Tools
1485 South 300 West
Phone: 801 486-7519

SAN FRANCISCO, CALIFORNIA 94080
Montague-Harris & Company
1423 San Mateo Avenue
Phone: 415 871-1900

SEATTLE, WASHINGTON 98108
Buckner-Weatherby Co., Inc.
5931 Fourth Avenue South
P. O. Box 80946
Phone: 206 767-3620

SHREVEPORT, LOUISIANA 71103
Richards Machinery & Supply Co.
5400 Interstate Avenue
P. O. Box 3900
Phone: 318 636-4416

ST. LOUIS, MISSOURI 63141
Zimco Machinery Co.
1984 Congressional Drive
Phone: 314 432-8063

SYRACUSE, NEW YORK 13057
R. H. Britton Machinery Sales, Inc.
6399 East Molloy Road
Phone: 315 437-3309

TULSA, OKLAHOMA 74115
Royal Machine Tools, Inc.
1719 N. Sheridan Road
Phone: 918 836-6646

WICHITA, KANSAS 67213
Ernst-Eichman Machinery Corp.
1970 So. West St.
Unit 315
Phone: 316 943-0278

Canadian Distributor

MONTREAL 377 P.Q. CANADA
Ferro Technique Ltd.
695 Montee de Liesse
Phone: 819 341-3450

TORONTO, ONTARIO L4W 2K8 CANADA
Ferro Technique Ltd.
1707 Sismet Road, Unit 7
Phone: 416 624-2770