

HARDINGE

MAINTENANCE MANUAL

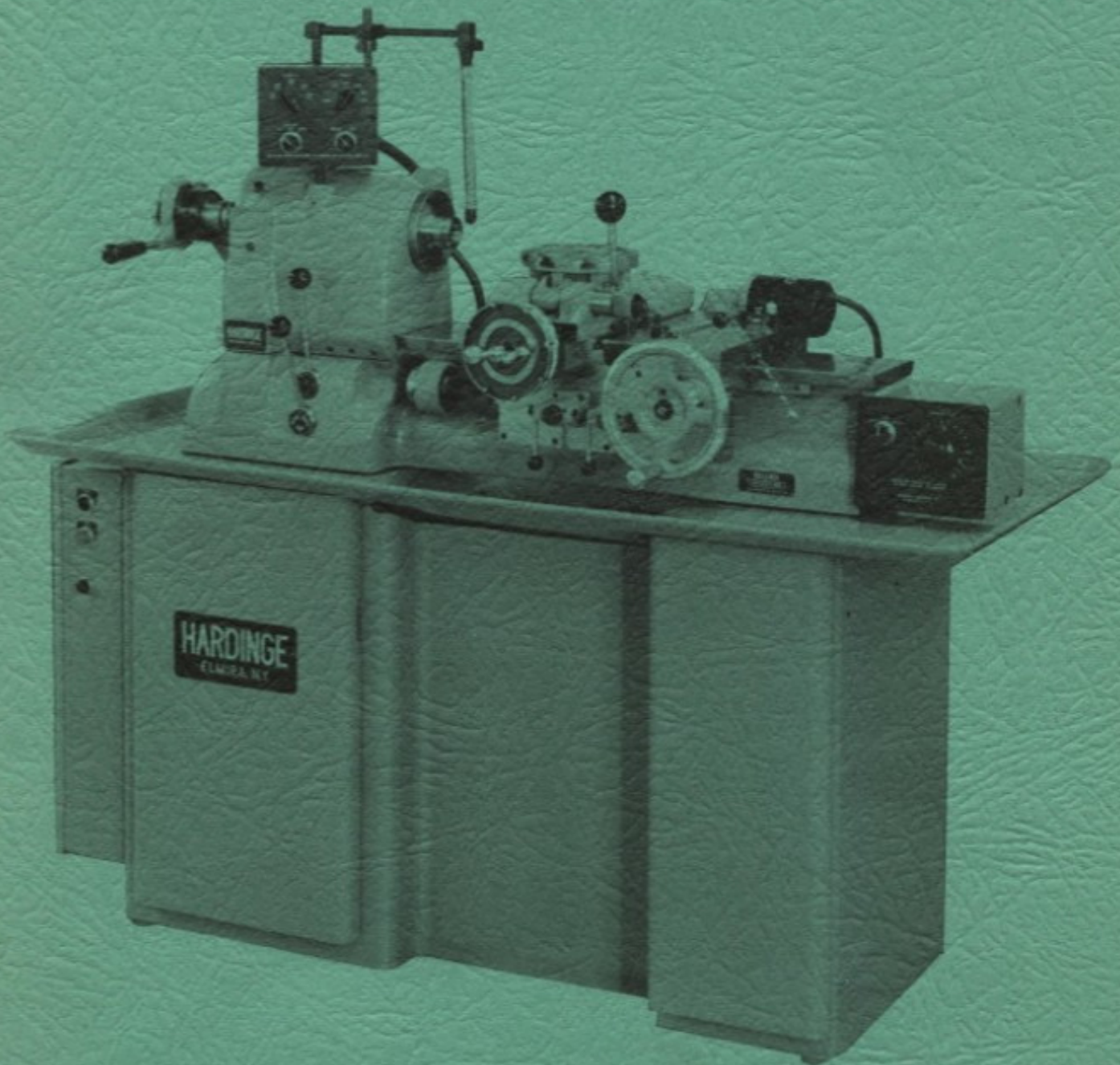

HC CHUCKING MACHINE

**READ COMPLETE INSTRUCTIONS CAREFULLY
BEFORE OPERATING MACHINE**

When this instruction book was printed, the information given was current. However, since we are constantly improving the design of our machine tools, it is possible that the illustrations and descriptions may vary from the machine you received. This means that the machine you received is the latest improved model to better fulfill your requirements.

HARDINGE SAFETY RECOMMENDATIONS

Your Hardinge machine is designed and built for maximum ease and safety of operation.

However, some previously accepted shop practices may not reflect current safety practices and procedures, and should be re-examined to insure compliance with the current safety and health standards.

We recommend that all shop supervisors, maintenance personnel, machine and tool operators be advised of the importance of safe maintenance, setup and operation of Hardinge-built equipment. Our recommendations are described below:

- DO** be sure equipment is properly grounded.
- DO** disconnect main electrical power before attempting repair or maintenance.
- DO** wear appropriate eye and foot protection and when necessary, respirator, helmet, gloves, and ear muffs or plugs.
- DO** be sure proper guarding is in place and all doors closed and secured.
- DO** keep chemical and flammable material away from electrical or operating equipment.
- DO** provide a safe, clean, work area free of slippery surfaces.
- DO** read appropriate manual or instructions before attempting operation or maintenance of a machine.
- DON'T** leave machine unattended while it is operating.
- DON'T** exceed the rated capacity of a machine.
- DON'T** operate equipment unless proper maintenance has been regularly performed and the equipment is known to be in good working order.
- DON'T** operate any equipment if unusual or excessive noise or vibration occurs.
- DON'T** operate any equipment while any part of the body is in the proximity of potentially hazardous areas.
- DON'T** use any toxic or flammable substance as a solvent cleaner, or coolant.
- DON'T** allow the operation or repair of equipment by untrained personnel.
- DON'T** check finishes or dimensions of workpiece near running spindles.
- DON'T** clean machine with air hose.
- DON'T** operate any machine with rings, watches, jewelry, loose clothing, ties, or long hair which is not contained by net or shop cap.

FOR YOUR OWN PROTECTION — WORK SAFELY

HARDINGE BROTHERS, INC.
Elmira, New York 14902

CONTENTS

	PAGE
Belts—Adjustment	3
Replacement	3
Brake, Spindle	5
Adjustment	5
Insert Replacement	5
Solenoid Replacement	5
Spring Replacement	6
Carriage—Clutch and Gearbox Lubrication	24
Disassembly	26
Gib Adjustment	24
Handwheel Disassembly	35
Lock Removal	26
Lubrication	24, 34
Rack Removal	33
Reassembly	31
Collet Closer—Removal	36
Replacement	36
Coolant Facilities	37
Cross Feed Screw and Dial—Removal	32
Replacement	33
Drive—Brake Adjustment	12
Cartridge—Removal	10
Disassembly	10
Replacement	11
Feed Screw Nut—Removal	11
Replacement	12
Lubrication	6
Micro Switch	12
Pulleys and Shaft Assembly Removal	14
Speed Change Mechanism—Removal	6
Replacement	8
Speed Change Motor, Brake and Vertical Screw Disassembly	6
Speed Change Motor Disassembly	9
Electrics—Main Switch Case	38
Power Feed Control Panel	17
Variable Speed Control Panel	12
Headstock—Removal	36
Replacement	37
Lubricants and Sealer	39
Maintenance, Preventive	2
Power Feed—Control Panel	17
Drive	15
Lubrication	14
Spindle—Limit Switch	36
Lock Pin	36
Lubrication	36
Turret and Cross Slide	18
Removal	18
Replacement	18
Disassembly	19
Feed Screw Nut—Removal	24
Replacement	24
Adjustment	24
Gib Adjustment	19
Index Lever and Lock—Disassembly	21
Reassembly	23

PREVENTIVE MAINTENANCE

DAILY

	PAGE
Oil brake insert	5
Run drive through complete speed range	6
Operate carriage pressure oiler	24

WEEKLY

	PAGE
Lubricate carriage gear rack	24
Remove, clean and lubricate collet closer	36

MONTHLY

	PAGE
Check drive belt tension	3
Lubricate drive	6
Lubricate turret indexing mechanism	18
Lubricate cross feed screw nut	18

BI-MONTHLY

	PAGE
Change oil in apron	24

QUARTERLY

	PAGE
Clean and lubricate cross slide ways	18

DEPENDING ON USE

	PAGE
Keep carriage oil reservoir full	24
Keep oil in sight window of apron	24
Keep power feed reservoir full	14
Clean coolant sump	37

SEE PAGE 39 FOR LUBRICANT AND SEALER VENDORS

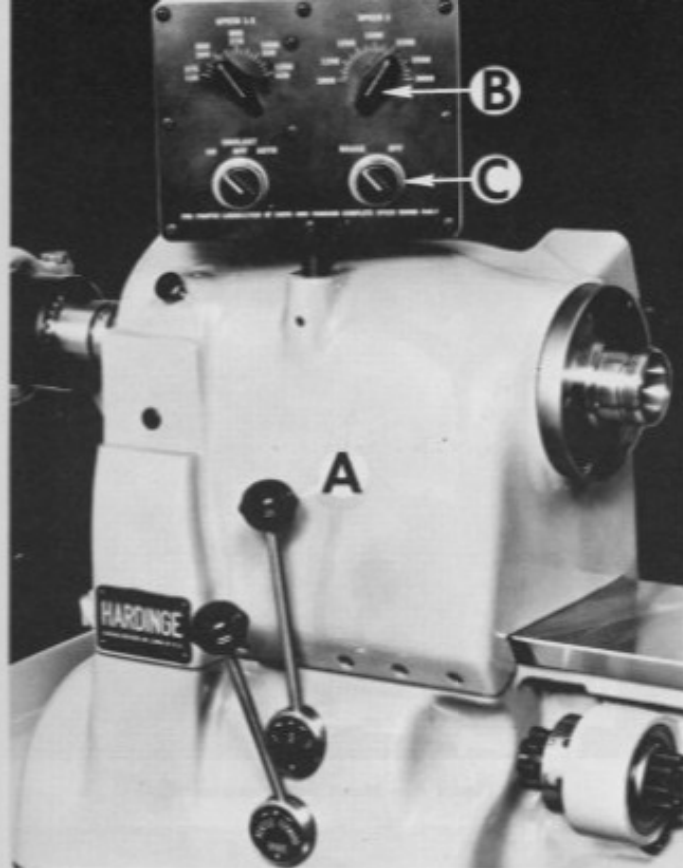

Figure 1

DRIVE BELT ADJUSTMENT

To check belts for proper tension, place lever "A", Figure 1, in range 3 and set selector "B" at 1100 R.P.M. Turn brake button "C" to "Off" position. Start machine spindle and allow it to coast to a stop. There should be no "looseness" in the belts and yet they should not be "drum tight". If belts slip when properly adjusted, machine is being overloaded.

TO ADJUST BELTS. loosen lock nut "A", Figure 2. Turn adjusting screw "B" clockwise to lower motor and tighten belts. Each time after adjusting, start machine spindle and allow it to coast to a stop with brake selector switch in "Off" position to allow belts to equalize their tension.

TO REPLACE DRIVE BELTS

1. Run pulley carrier to down position (low spindle speed, 125 R.P.M.)
2. Push stop button to **SHUT OFF MACHINE.**
3. Remove pedestal rear cover to prevent damage when motor mounting plate is raised.

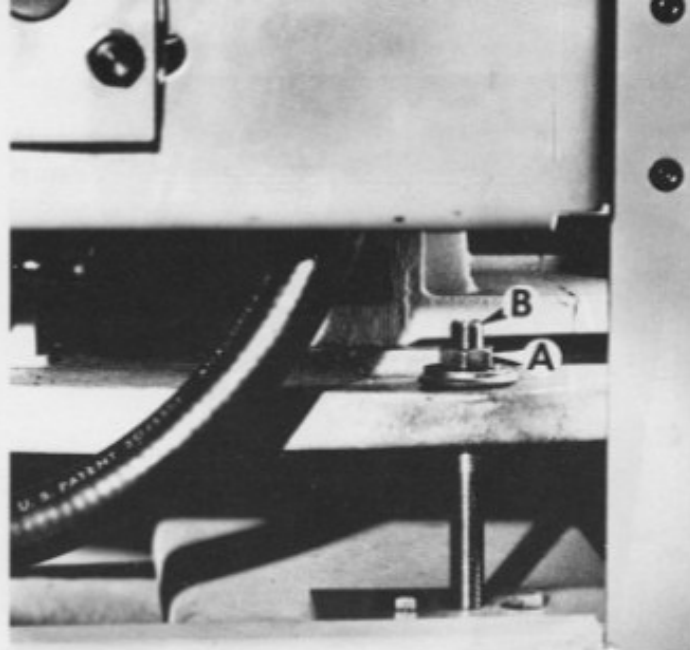

Figure 2 — Drive Belt Adjusting Screw

4. Remove lock nut "A", Figure 2.
5. Raise front of motor mounting plate approximately 2" and block, Figure 3.

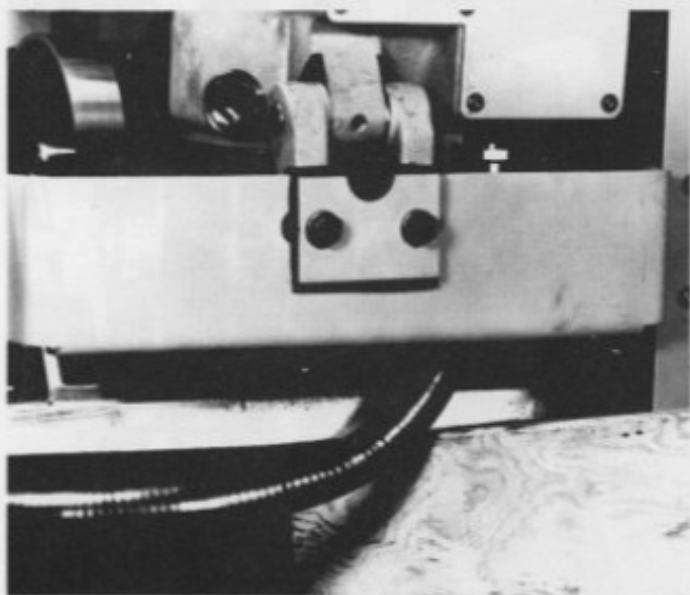

Figure 3

6. Roll motor belt to right off pulley and let it rest on pulley hub, Figure 4.

Figure 4



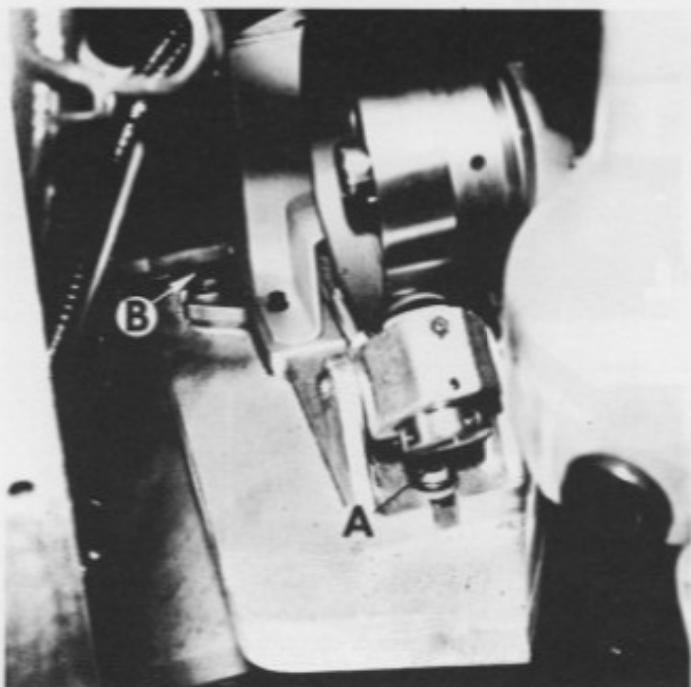

Figure 5 — Spindle Brake

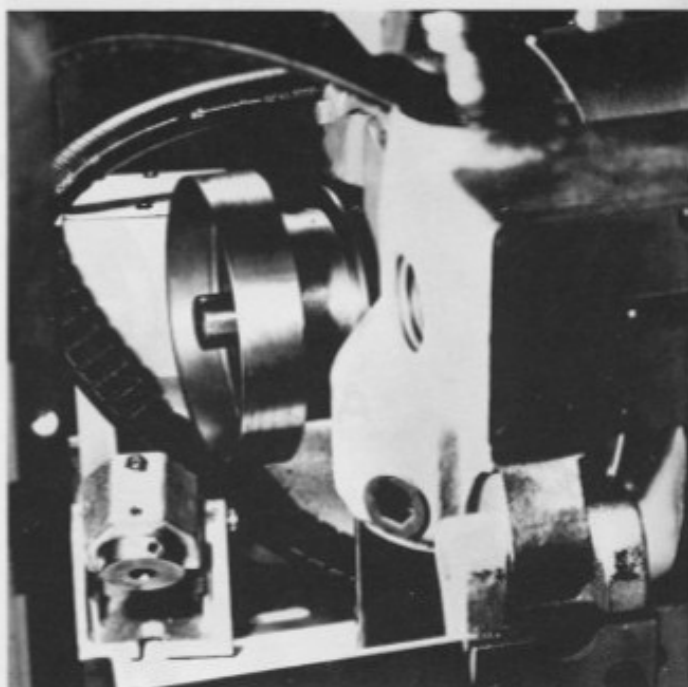

Figure 6 — Motor Belt Removal

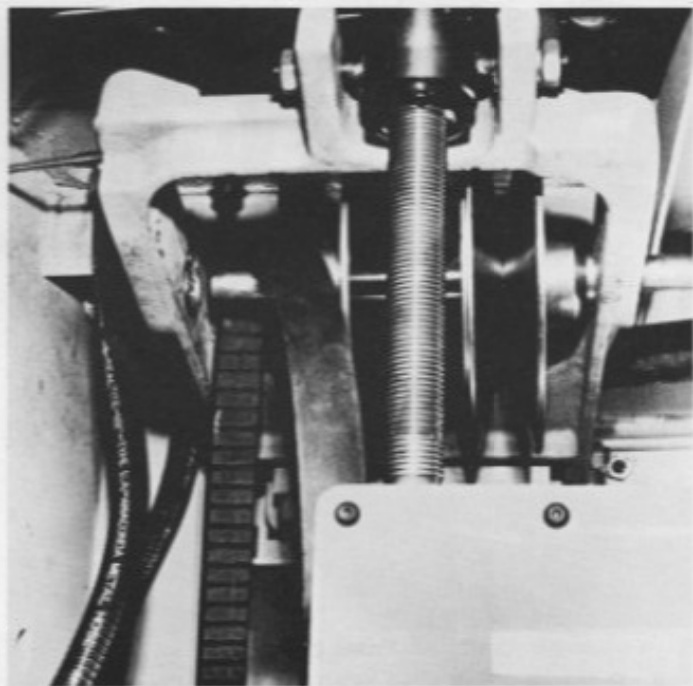

Figure 7 — Belt Removal from Countershaft

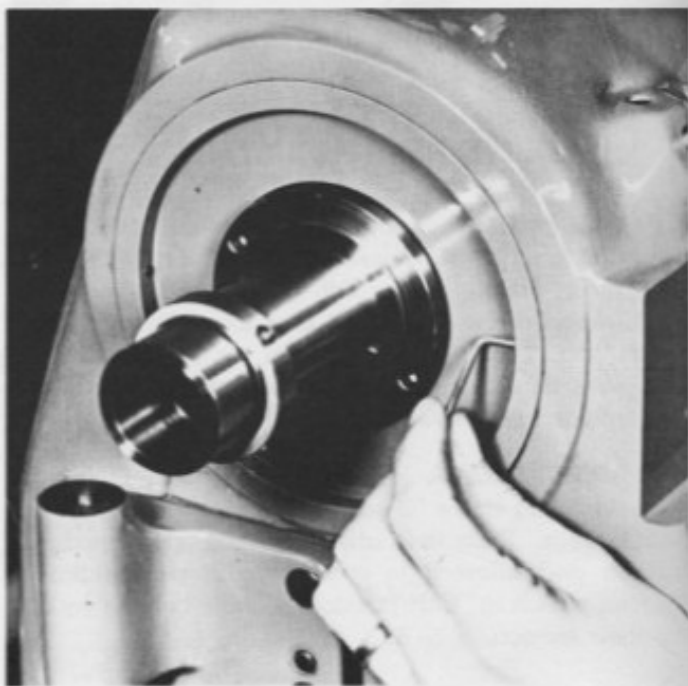

Figure 8 — Headstock Cover Removal

7. **TO REMOVE MOTOR BELT** from motor pulley, remove bolt "A", Figure 5, loosen bolt "B" and swing brake assembly to left, Figure 6.
8. Run pulley carrier to top position (high spindle speed, 3000 R.P.M.) by jogging forward-reverse lever.
9. Push stop button to **SHUT OFF MACHINE**.
10. Slide countershaft assembly to extreme right and remove belts over left end of countershaft, Figure 7.

11. **TO REMOVE HEADSTOCK BELT:**

- (a) Remove collet closer per Page 36.
- (b) Remove headstock cover by loosening two set screws, Figure 8.
- (c) Remove cotter pin from speed range pull rod which passes through headstock belt in motor compartment and move belt around end of pull rod.
- (d) Pull belt over end of spindle and up out of headstock, Figure 9.

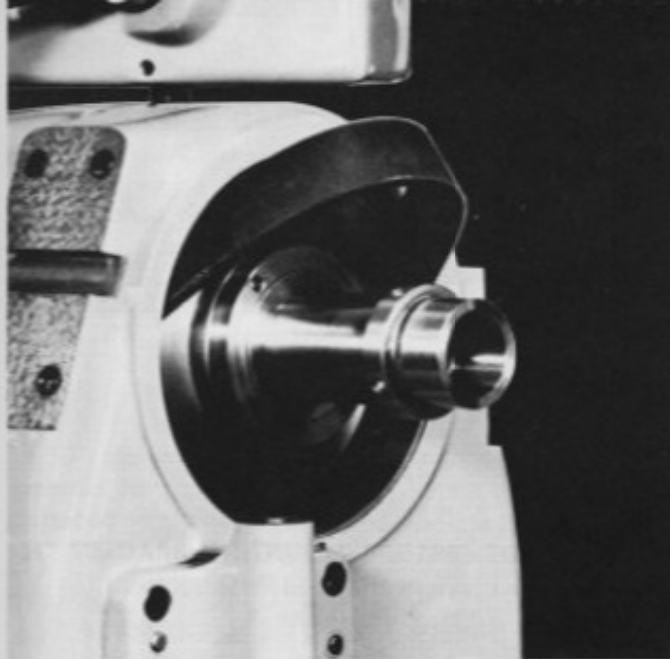

Figure 9 — Headstock Belt Removal

12. Reassemble with new belts and adjust for proper belt tension per Page 3. See instructions for brake adjustment on this Page.
13. Make checks as outlined in steps 9 and 10 under "Speed Change Mechanism Replacement", Page 9.

SPINDLE BRAKE

The spindle brake is built for rapid but gradual stopping of the precision headstock spindle at all speeds. The brake drum "D", Figure 10, is located directly on the main drive motor shaft. The brake is actuated when the brake insert "C" is forced against the brake drum by spring action and is released by a solenoid. **OIL BRAKE INSERT DAILY** with spindle oil or as often as necessary. Allowing insert to become dry will reduce belt and brake life excessively.

Figure 10 — Spindle Brake

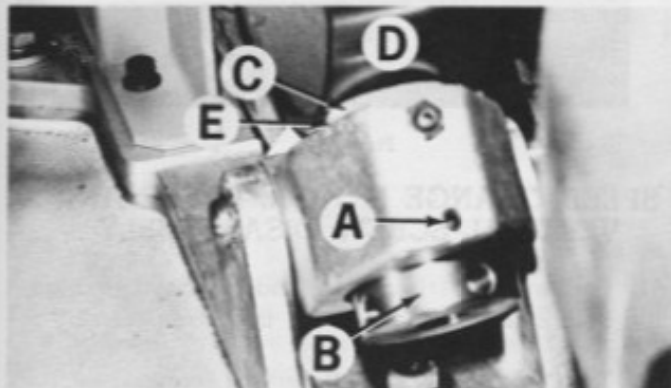

Brake Adjustment

After considerable use it may be necessary to adjust brake. With power on and brake selector in "Off" position, loosen set screw "A", Figure 10, and turn adjusting collar "B" to the right with a pin wrench until there is .005" clearance between the insert "C" and drum "D". Relock set screw "A".

To Replace Brake Insert

Loosen set screw "A", Figure 10, and unscrew collar "B". Remove housing "E" and knock out old insert. Place new insert on flat surface and, using a rawhide mallet, drive housing "E" over insert until 3/16" to 1/4" of insert projects from housing.

When reassembling, line up keyway of housing "E" with key before starting adjusting collar "B". Set clearance as when adjusting brake and relock set screw "A". Oil brake insert with spindle oil and operate brake 25 times. Readjust brake.

Brake Solenoid Replacement

1. Remove cover "F", Figure 11. Disconnect solenoid wires under cover. Remove conduit connector "G" from brake housing.
2. Remove two screws "H" and brake housing "J".

Figure 11 — Brake Solenoid Cover

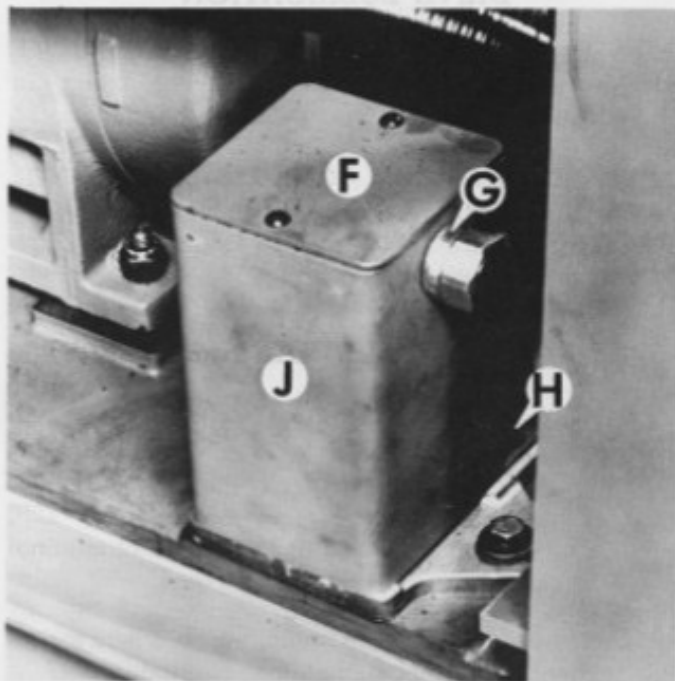

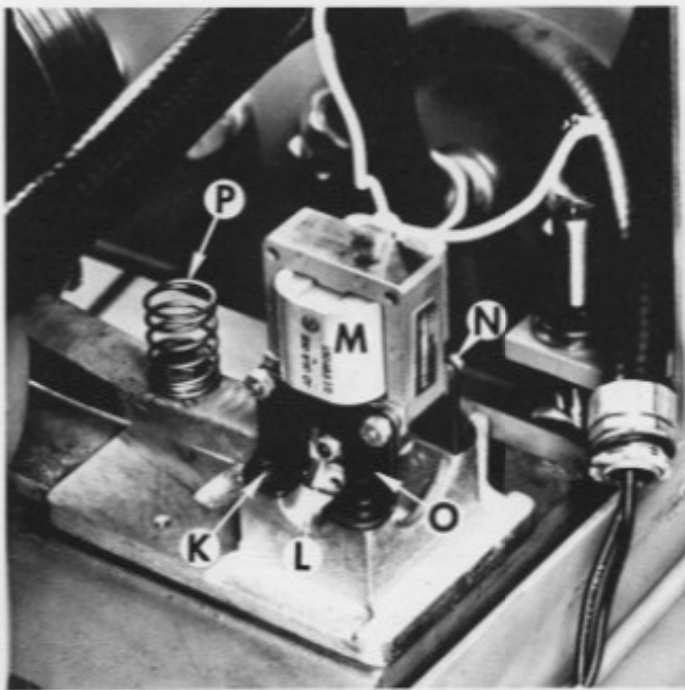

Figure 12 — Spindle Brake Solenoid

3. Remove four screws "K", Figure 12, and nut and screw "L" to remove solenoid "M".
4. Remove screws "N" to remove supports "O" from solenoid "M".

Brake Spring Replacement

1. Follow steps 1 and 2 under "Solenoid Replacement" Page 5.
2. Remove spring "P", Figure 12.

DRIVE LUBRICATION

Grease at fitting "A", Figure 13, with Houghton Absorbed Oil #L-4½. Grease is sufficient when forced out of slot in fitting "A". Lubricate once a month or more often if necessary. **FOR PROPER LUBRICATION OF DRIVE, RUN THROUGH COMPLETE SPEED RANGE DAILY.** The main drive motor and the speed change motor bearings are grease packed for life and require no further lubrication.

SPEED CHANGE MECHANISM REMOVAL

1. Run pulley carrier to down position (125 R.P.M.).
2. Disconnect electric power source.
3. In main switch case remove wires T1R, T2R, T3R, 15, 16, 19 and 20 at lower side of terminal blocks, Figure 14.
4. Remove green ground wire, which enters switch case from same conduit, from ground post "A".

5. Remove fine wires 26, 27 and 33, which enter switch case from same conduit, from terminal blocks.
6. Remove nut "B", Figure 15, from conduit connector and pull wires into pedestal.
7. Loosen two nuts "C", Figure 13, and loosen pivot screws "D" to clear feed screw nut "E".
8. Loosen set screw "F".
9. Support control housing and remove pin "G" to left with brass punch. Angle control housing (vertical screw to left) and remove from pedestal. **DO NOT DISTURB MOUNTING BRACKET "H"** which is factory adjusted for alignment.

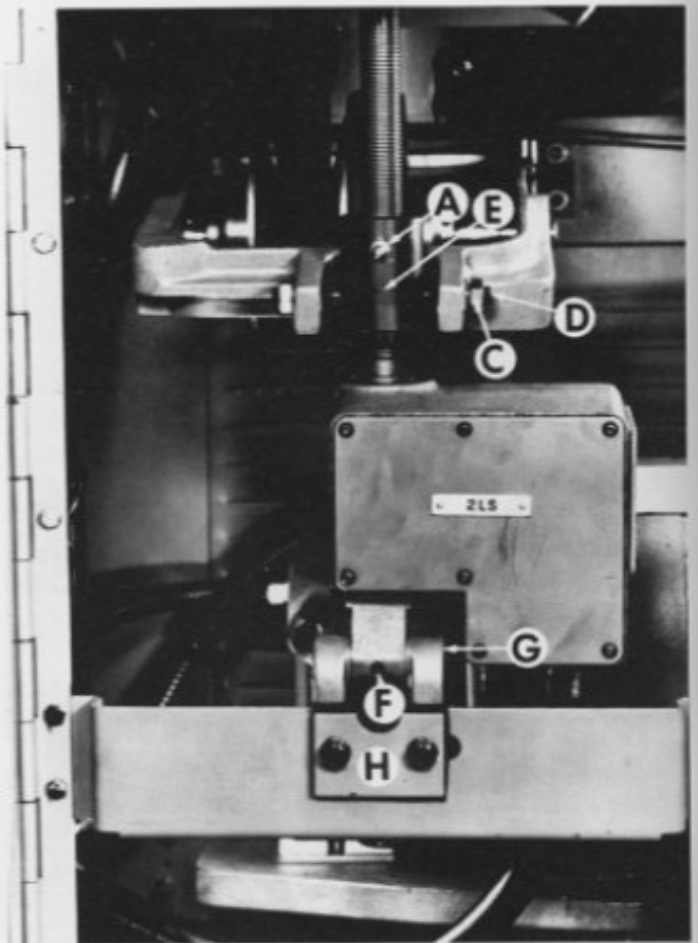

Figure 13

SPEED CHANGE MOTOR, BRAKE AND VERTICAL SCREW DISASSEMBLY

1. Follow steps 1 through 9 under "Speed Change Mechanism Removal", on this Page.
2. Turn feed screw nut off vertical screw.

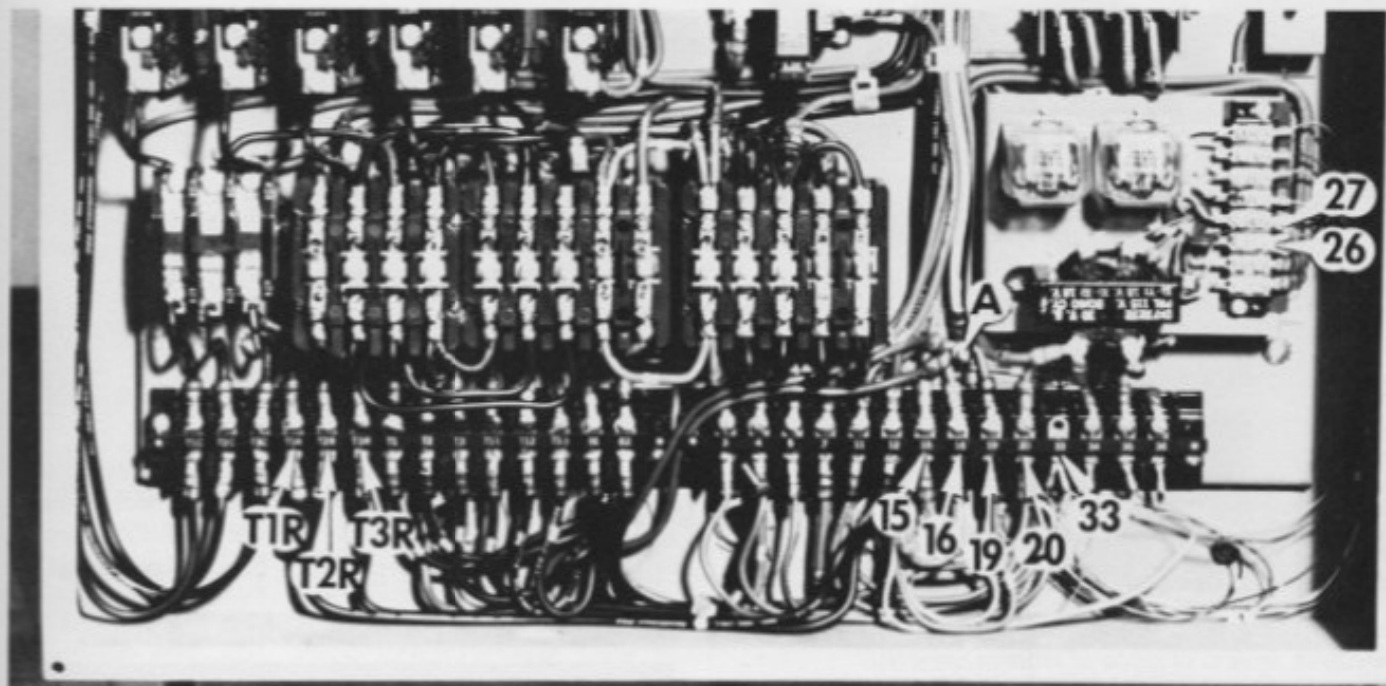

Figure 14 — Main Switch Case

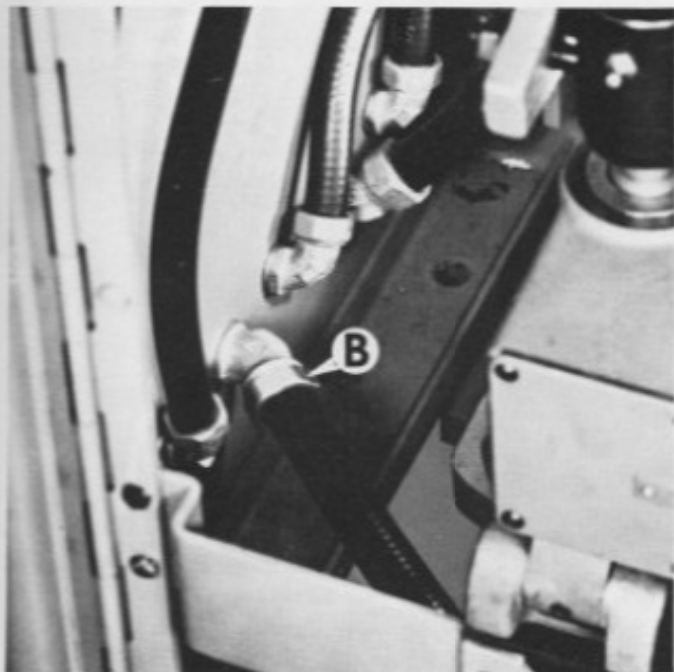

Figure 15

3. Remove covers "J" and "K", Figure 16.
4. Disconnect three black wires (motor leads) and two blue wires (brake leads).
5. Remove set screw at "L", Figure 17, and loosen lock screw under set screw. Slide cartridge assembly out of engagement with vertical screw, Figure 17.

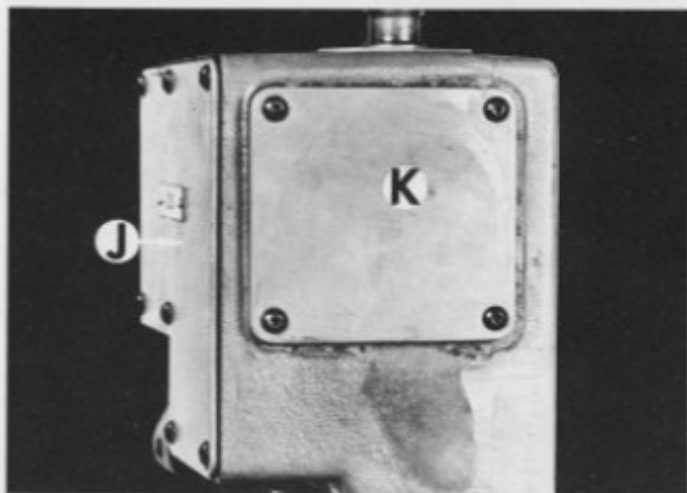

Figure 16 — Drive Housing Covers

Figure 17 — Drive Worm and Worm Wheel Disengaged

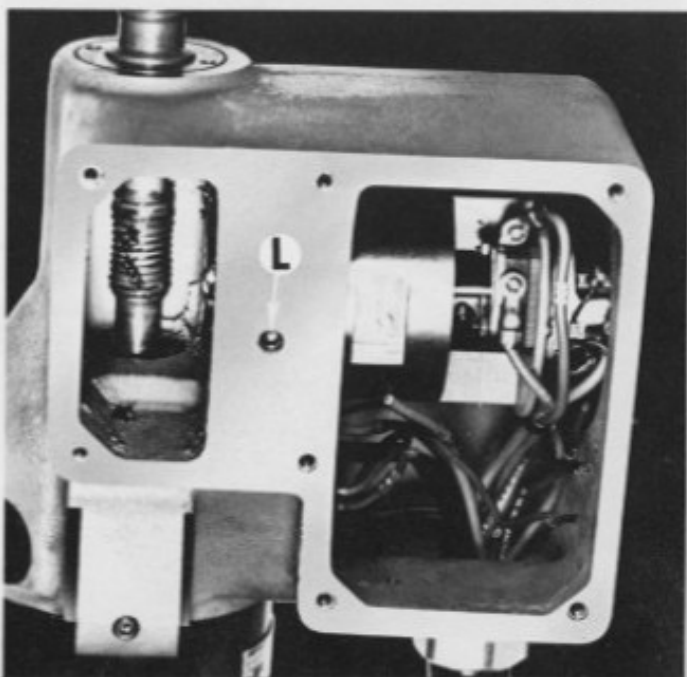



Figure 18 — Speed Change Motor

6. Remove two screws "M", Figure 18, and remove motor.
7. Remove four screws "N", Figure 19, and brake "O".
8. Remove spring "P", Figure 20.
9. Remove nut "Q", Figure 21, with adjustable spanner wrench and remove vertical screw assembly, Figure 22.
10. Remove snap ring "R", Figure 23, bearing "S", nut "T" and bearing "U" from vertical screw "V".
11. Follow steps 4 through 7 under "To Disassemble Speed Change Motor Assembly" Page 9.
12. Reassemble (align worm wheel with center line of vertical screw) and fill teeth of worm and wheel only with Andok "B" grease. Follow steps 2 through 4 under "Drive Brake Adjustment", Page 12.

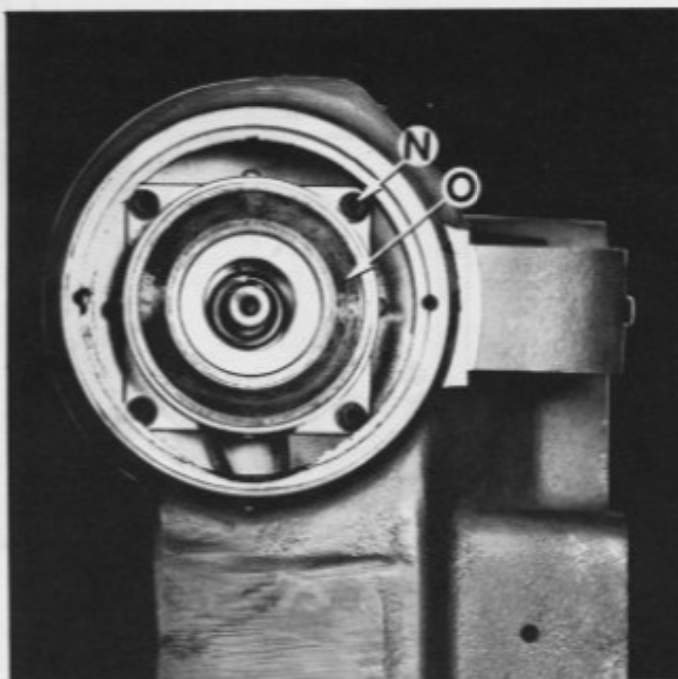

Figure 19 — Drive Brake

Figure 20 — Spring for Brake

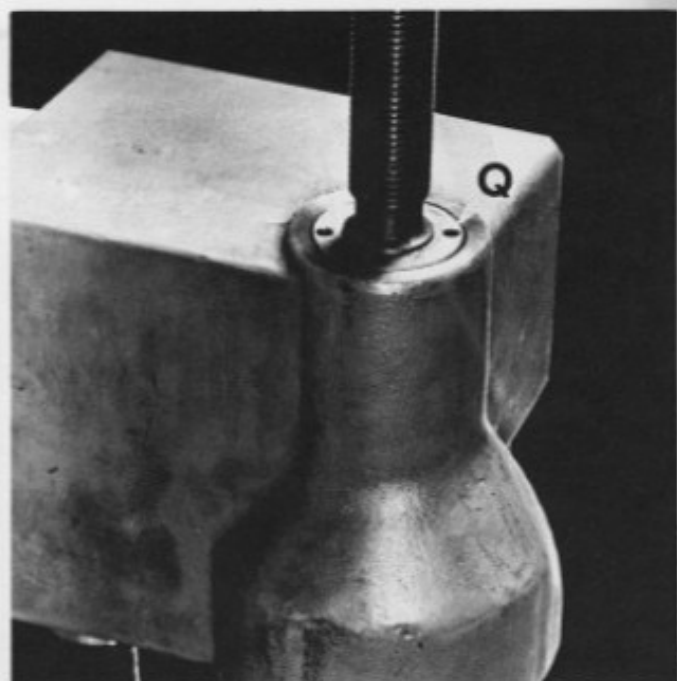
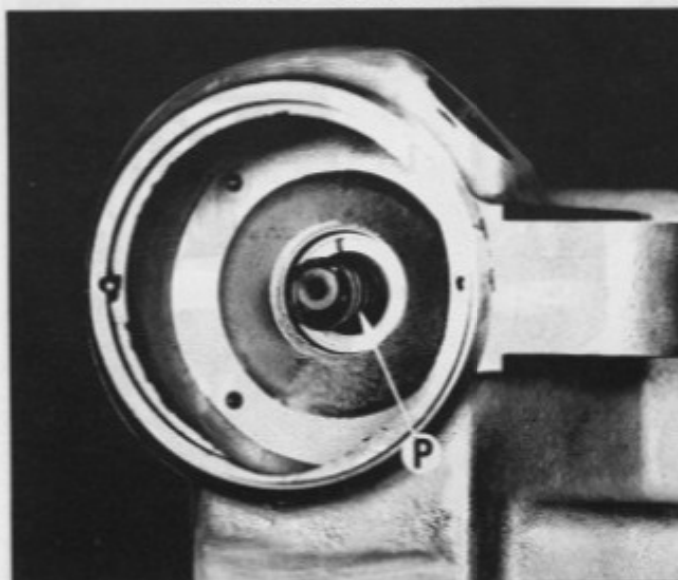

Figure 21 — Vertical Screw Retaining Nut

SPEED CHANGE MECHANISM REPLACEMENT

1. Place drive in pedestal and secure with pin "G", Figure 13, in mounting bracket. Tighten set screw "F". **DO NOT MOUNT FEED SCREW NUT "E"**.

Figure 22 — Vertical Screw Removal



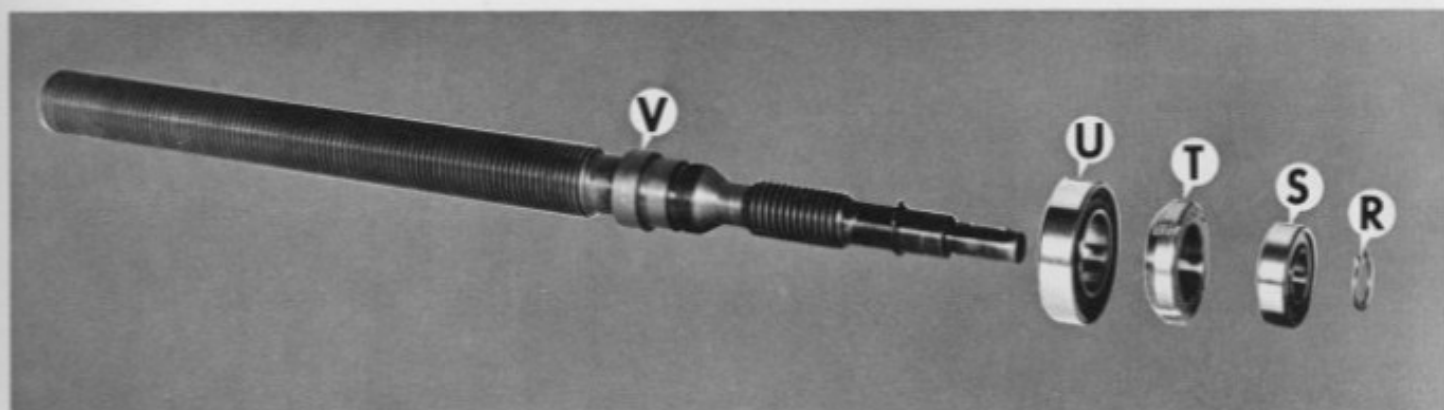

Figure 23— Vertical Screw Components

2. Feed wires through conduit elbow into switch case and replace conduit nut "B", Figure 15.
3. Replace wires in switch case, Figure 14.
4. To check drive rotation, set speed selectors at 125 and 3000. Place forward-reverse lever in "Brake" position. Push start button and pull spindle lock pin. Place speed range lever in range 3. **USING CAUTION**, jog forward-reverse lever. Vertical screw should rotate clockwise as viewed from top. (When speed range lever is moved to range 2, vertical screw should rotate counterclockwise when viewed from top). If vertical screw does not rotate as described, disconnect power source and interchange any two wires (T1R, T2R, T3R) on terminal block in switch case, Figure 14.
5. Run drive to low speed (125 R.P.M.) and shut off machine.
6. Thread feed screw nut onto vertical screw. Hold loose half nut flush with housing until threads engage. Hand feed feed screw nut down to within three to five threads from bottom of vertical screw (with grease fitting in front).
7. Line up pivot screws in pulley carrier with feed screw nut. (Pulley carrier can be positioned up or down when spindle is running.)
8. Turn screws into pivot holes in feed screw nut to align drive. Lock nuts on pivot screws. Vertical screw should turn freely by hand when machine is shut off at stop button. Run drive through speed range to check alignment.
9. Stop spindle at low speed (125 R.P.M.). O.D. of motor belt should be flush to 1/16" out of pulley.

Make corrections, **IF NECESSARY**, by loosening pivot screws "D", Figure 13, and rotating feed screw nut accordingly. Feed screw nut can be turned 180° by interchanging grease fitting and pipe plug. Run spindle after each adjustment, allowing spindle to coast to a stop, to allow belts to equalize tension.

10. Stop spindle at high speed (3000 R.P.M.). O.D. of headstock belt should be flush to 1/16" out of pulley. Make corrections, **IF NECESSARY**, at rheostat "A", Figure 36, in control head. Turn rheostat knob gradually clockwise to bring headstock belt out of pulley.

TO DISASSEMBLE SPEED CHANGE MOTOR ASSEMBLY

1. Remove cover "J", Figure 16.
2. Disconnect three black wires (motor leads).
3. Remove two screws "M", Figure 18, and remove motor.
4. Remove motor cap "W", Figure 24. Do not misplace two bearing spacers "X".
5. Remove brake disc "Y" and armature "Z".

Figure 24— Speed Change Motor Components

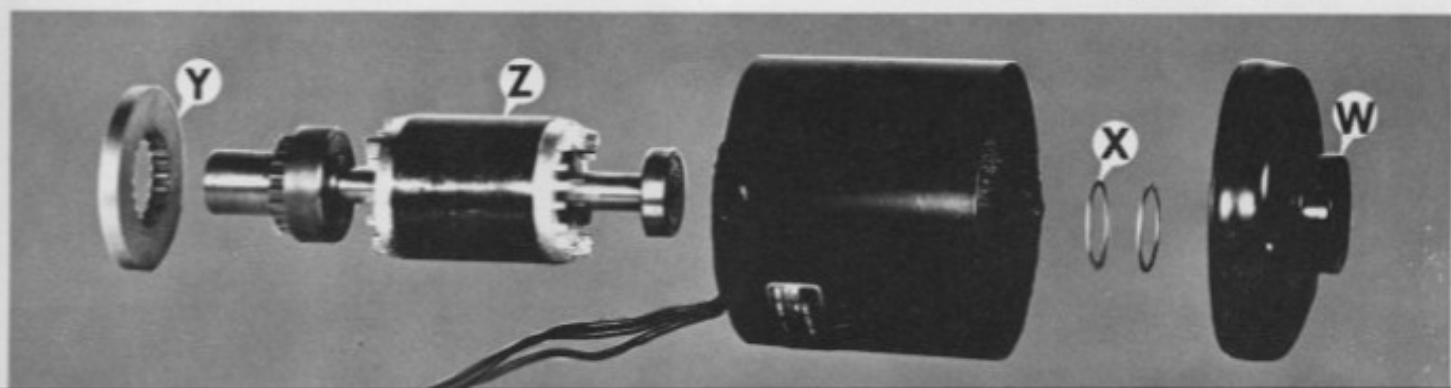

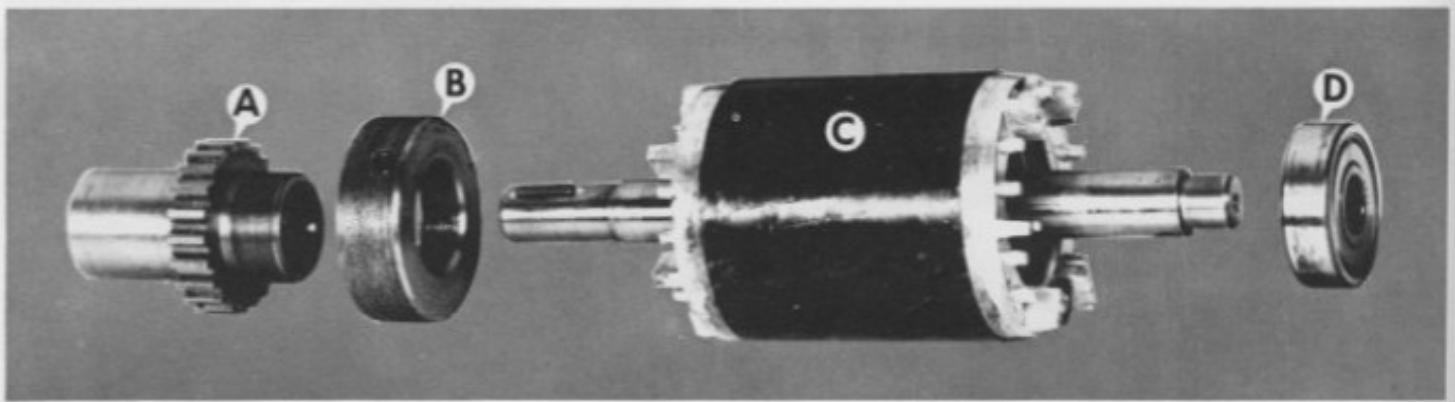

Figure 25 — Armature for Speed Change Motor

6. Press armature hub "A", Figure 25, and bearing "D" from armature shaft "C".
7. Loosen set screw to turn brake adjusting collar "B" off armature hub. (Do not misplace nylon plug under set screw.)
8. Reassemble and follow steps 2 through 4 under "Drive Brake Adjustment", Page 12.

DRIVE CARTRIDGE REMOVAL

1. Remove covers "J" and "K", Figure 16.
2. Remove two red wires from micro switch.
3. Unsolder wires, 26, 33 and 27, Figure 26, from rheostat terminals.

6. Remove drive cartridge, Figure 27, from housing by pulling straight out.

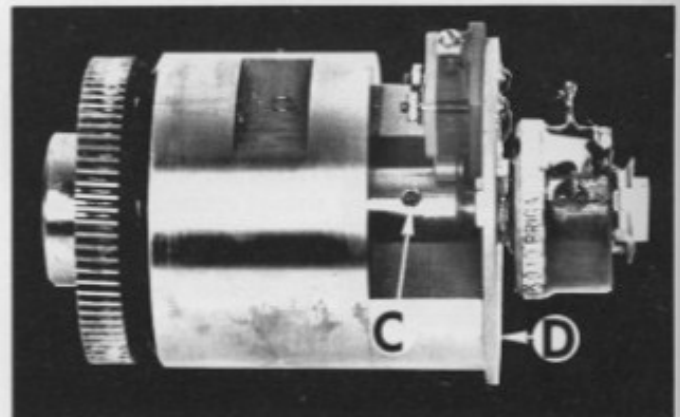

Figure 27 — Drive Cartridge

DRIVE CARTRIDGE DISASSEMBLY

1. Remove lock screw "C", Figure 27, and loosen set screw under lock screw "C".
2. Remove remaining screw and cover "D".
3. Remove nut "A", Figure 28, to remove rheostat "B".

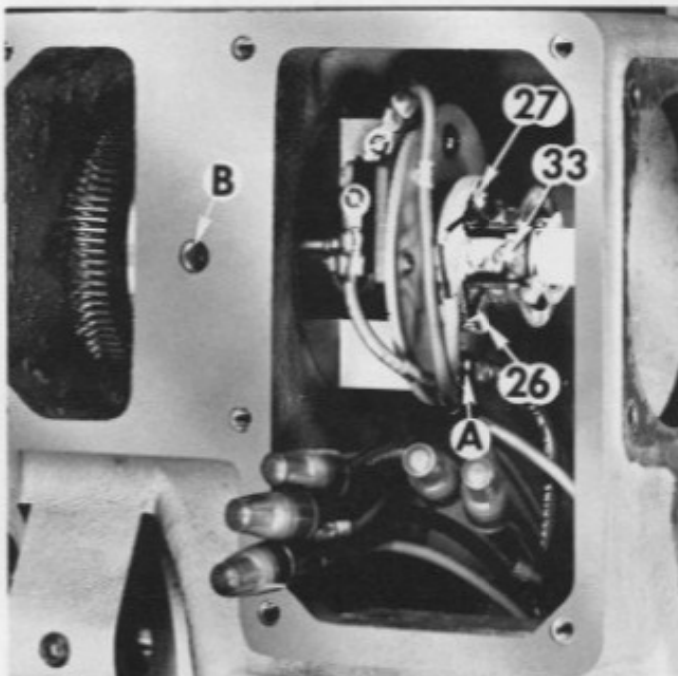
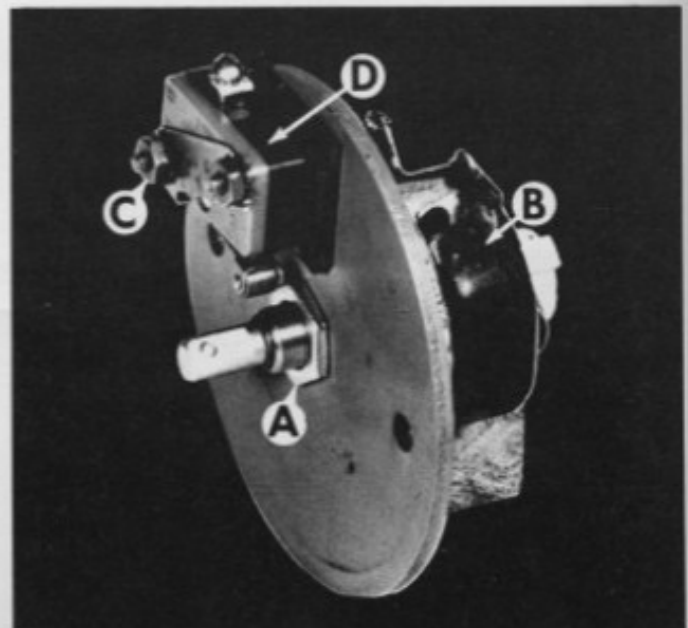

Figure 26 — Drive Housing

4. Remove screw "A" to remove wire clamp and ground wire.
5. Remove lock screw "B" and loosen set screw under lock screw "B".

Figure 28 — Drive Micro Switch and Rheostat



4. If necessary, remove two nuts "C" to remove micro switch "D".
5. Hold shaft "E", Figure 29, with hex pin wrench and remove nut "F" with adjustable spanner wrench. Remove worm wheel "G".

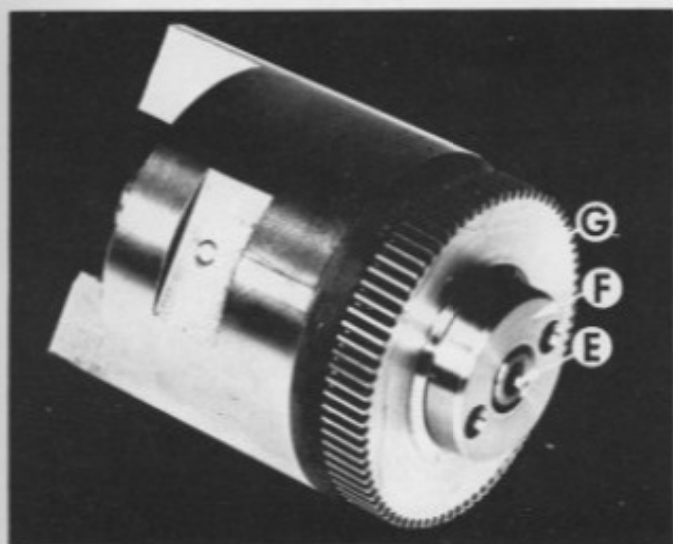

Figure 29 — Worm Wheel and Drive Cartridge

6. Remove woodruff key "A", Figure 30.
7. Tap shaft with plastic mallet at keyway end to remove shaft "E", bearing "B" and spacer "C". Remove bearing "D" from housing "F".
8. If necessary, remove screw "G" and cam "H".

DRIVE CARTRIDGE REPLACEMENT

1. Reassemble drive cartridge, Figure 27, and replace in drive housing.
2. Align worm wheel with center line of vertical screw. Replace set screw and lock screw "B", Figure 26. Fill teeth of worm and wheel only with Andock "B" grease.
3. Replace two red wires on micro switch and solder wires 26, 33 and 27 to rheostat terminals, Figure 26.

Figure 30 — Drive Cartridge Housing and Components

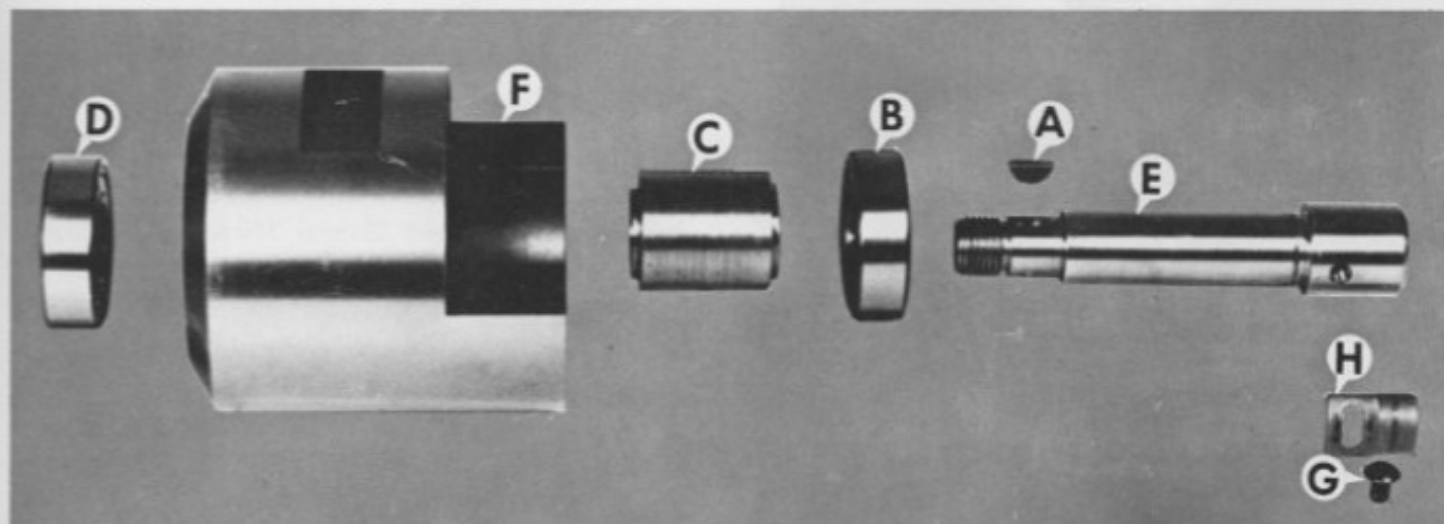

4. Replace clamp "A" and ground wire, Figure 26. **DO NOT OPERATE MACHINE.**
5. Loosen two nuts "C", Figure 13, and loosen pivot screws "D" to clear feed screw nut "E".
6. Hand feed nut "E" down to within three to five threads from bottom of vertical screw (with grease fitting in front).
7. Run drive to low speed (125 R.P.M.) and shut off machine.
8. Follow steps 7 through 10 under "Speed Change Mechanism Replacement", Page 9.
9. Follow steps 1 through 4 under "Drive Micro Switch Adjustment", Page 12.

DRIVE FEED SCREW NUT REMOVAL

1. Loosen two nuts "C", Figure 13, and loosen pivot screws "D" to clear feed screw nut "E".
2. Hand feed nut "E" up and off vertical screw.
3. Remove half nut "A", Figure 31.
4. Remove nut "B" to remove half nut "C" and spring "D" from housing "E".
5. Grease fitting "F" can be interchanged with plug "G" for adjustment purposes when reassembling.

Figure 31 — Drive Feed Screw Nut

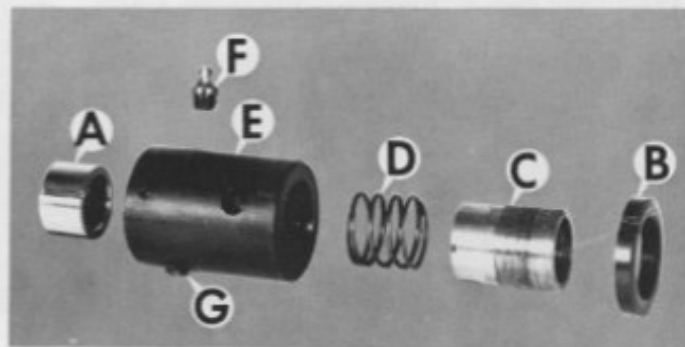

DRIVE FEED SCREW NUT REPLACEMENT

1. Follow steps 5 through 9 under "Speed Change Mechanism Replacement", Page 9.

DRIVE BRAKE ADJUSTMENT

1. Shut machine off at stop button to release brake.
2. Remove plug "A", Figure 32.
3. Loosen set screw "B", Figure 33.

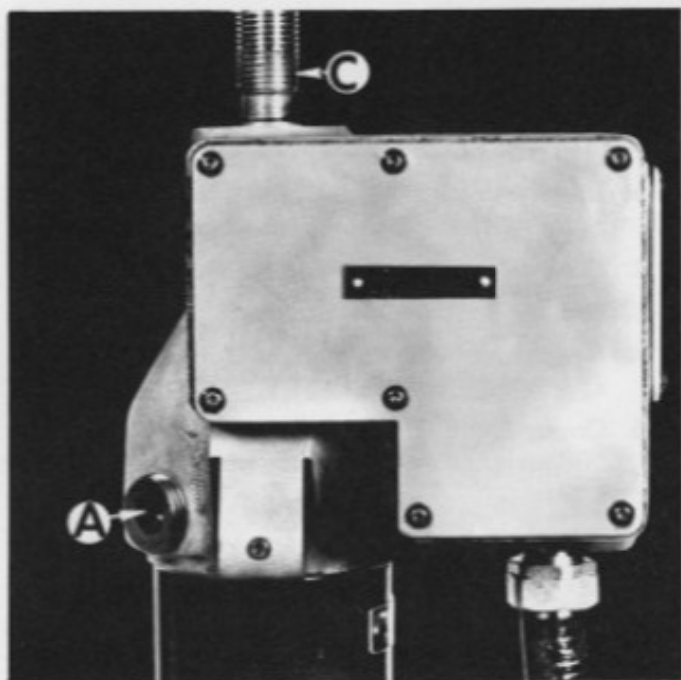

Figure 32 — Drive Brake Plug and Vertical Screw

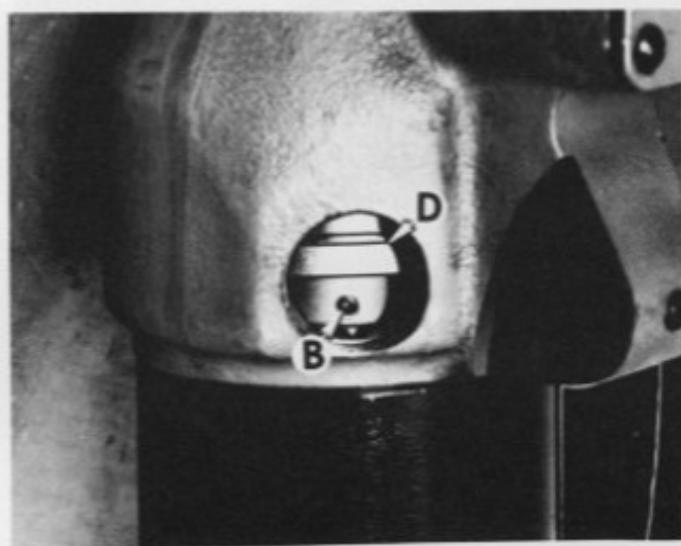

Figure 33 — Drive Brake

4. Hold adjusting collar with pin wrench in screw "B" and turn vertical screw "C", Figure 32, by hand until .010 to .015" clearance is achieved between brake and brake disc at point "D". Tighten screw "B".

DRIVE MICRO SWITCH

The drive micro switch "A", Figure 32, is a safety feature to prevent drive from over-running top or bottom. When properly set, the micro switch will permit 1½ to 3 turns of vertical screw beyond extreme speeds before switch is engaged cutting power to variable speed motor.

Drive Micro Switch Adjustment

1. Run drive to top speed (3000 R.P.M.). Push stop button. Mark vertical screw and nut "Q", Figure 21, with pencil or crayon. Remove cover "J", Figure 16. Turn vertical screw by hand clockwise (as viewed from top) and count revolutions of vertical screw before click of micro switch is heard.
2. Back drive off micro switch by hand and run drive to low speed (125 R.P.M.). Push stop button. Mark vertical screw and nut "Q", Figure 21, with pencil or crayon. Turn vertical screw by hand counterclockwise (as viewed from top) and count revolutions of vertical screw before click of micro switch is heard.
3. If vertical screw has a total of more than six turns beyond extreme speeds, loosen screw "C", Figure 34, and pivot micro switch "A" toward cam "B".
4. If vertical screw has a total of six or less turns beyond extreme speeds, but more turns either top or bottom, loosen screw "D" and adjust cam to equally divide turns for 1½ to 3 revolutions top and bottom.

VARIABLE SPEED CONTROL PANEL

To gain access to variable speed control panel, remove eight screws "E", Figure 35.

Speed trimming rheostat "A", Figure 36, is used to set top speed after changing belts or repairing drive (see step 10 under "Speed Change Mechanism Replacement", Page 9).

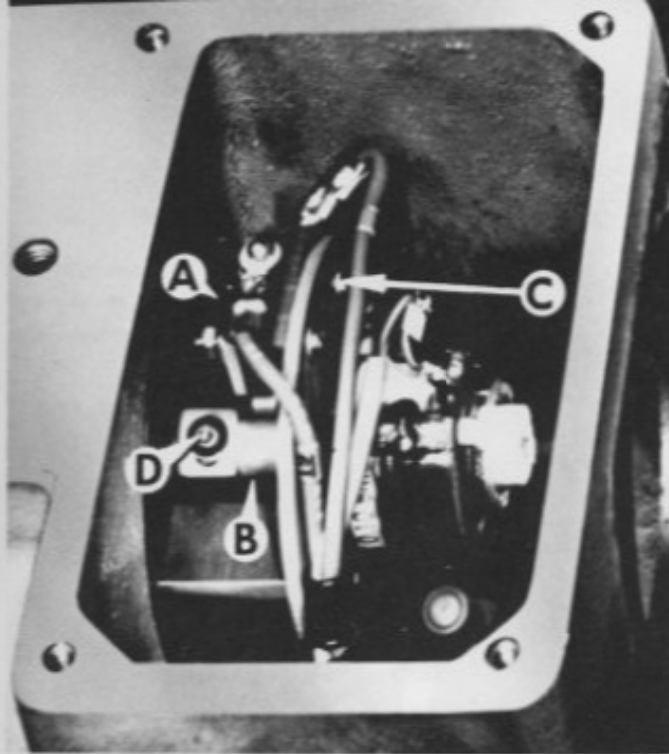

Figure 34 — Drive Micro Switch and Cam



Figure 35 — Variable Speed Control Panel

Sensitivity rheostat "B", Figure 37, is used to stabilize transistors. When surrounding temperature exceeds 100° F, drive may hunt for selected speed. Remove pipe plug in left side of control box. Turn adjusting knob counterclockwise with screw driver to maximum.

Rheostat "C" controls speeds in ranges 1 and 2 and rheostat "F" controls speeds in range 3. If drive fails to operate or hunts for speed, rheostat fields may be dirty

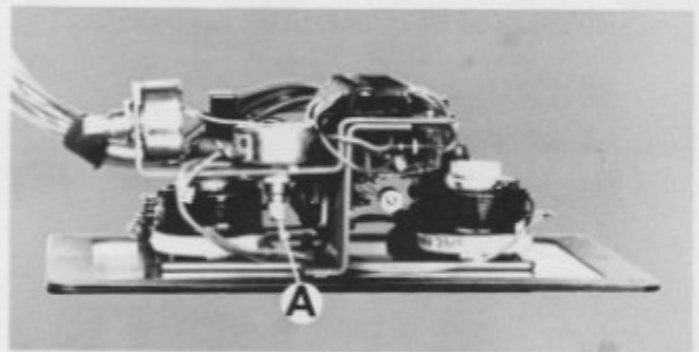

Figure 36 — Speed Trimming Rheostat

and should be cleaned with electrical contact cleaner. This holds true for rheostat in drive housing.

Selector switch "D" controls coolant and selector switch "E" controls spindle brake.

Transistor assembly "G" contains transistors "H" and "J", Figure 38. If drive operates in one direction only, interchange "H" and "J" to check for faulty transistor. Transistor "H" works in control circuit to lower drive and "J" to raise drive.

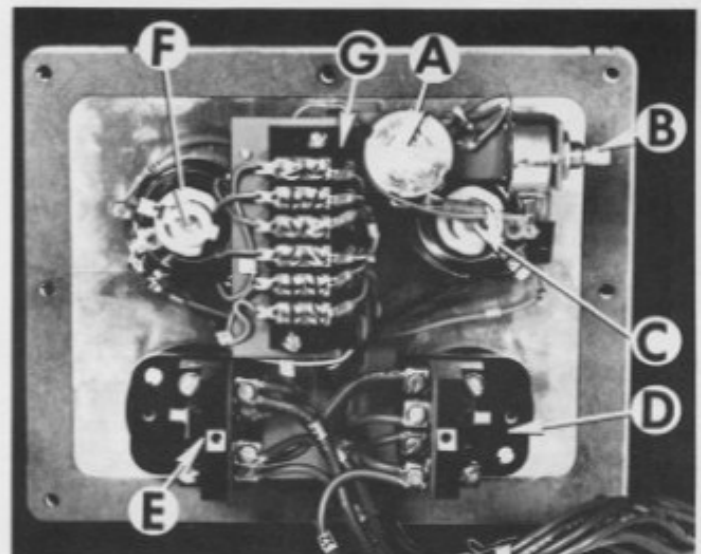
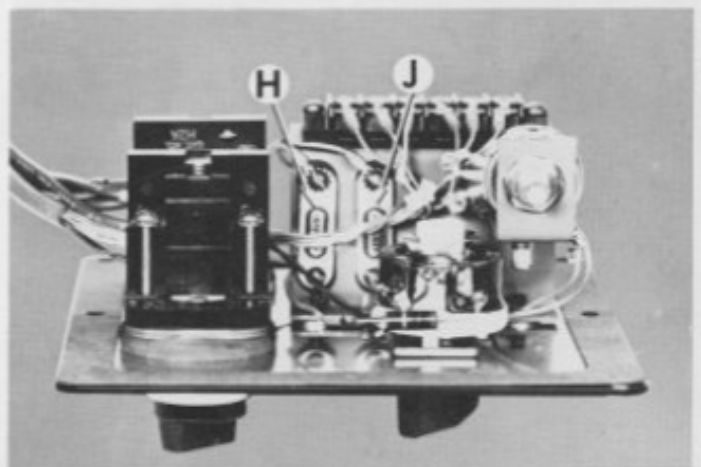

Figure 37 — Variable Speed Control Panel

Figure 38 — Control Panel Transistor Assembly



VARIABLE SPEED PULLEY AND SHAFT ASSEMBLY REMOVAL

1. Follow steps 1 through 5 under "To Replace Drive Belts", Page 3.
2. Remove snap ring, Figure 39, from right side of pulley carrier.

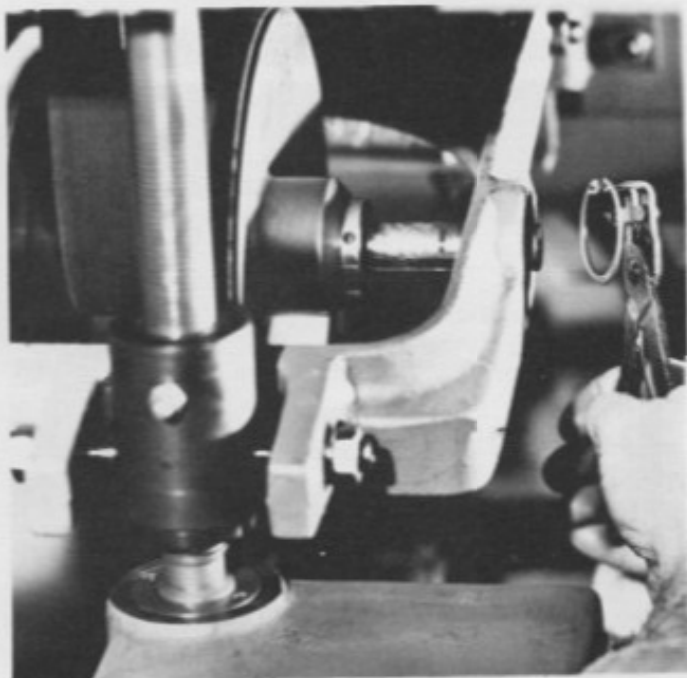
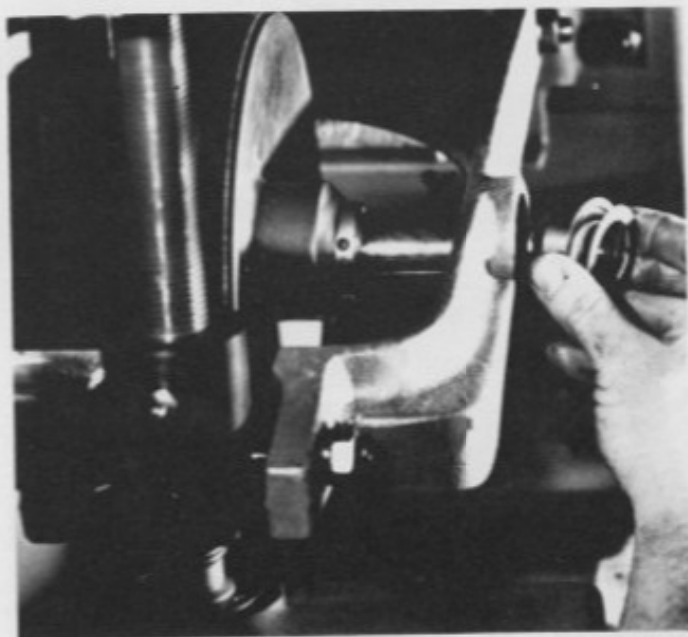

Figure 39 — Countershaft Snap Ring Removal

3. Remove bearing and spacer, Figure 40. (A small piece of sheet metal wrapped around shaft can be used to remove bearing and spacer.)
4. Move pulley shaft to the right out of remaining bearing and remove pulley and shaft assembly, Figure 41.

Figure 40 — Countershaft Bearing and Spacer Removal



5. Remove snap ring to remove remaining bearing and spacer.
6. Coat bearing surfaces of shaft with anti-seize molybde and reassemble. Adjust for proper belt tension per Page 3.
7. If replacement of pulley and shaft assembly was necessary, make checks as outlined in steps 9 and 10 under "Speed Change Mechanism Replacement", Page 9.

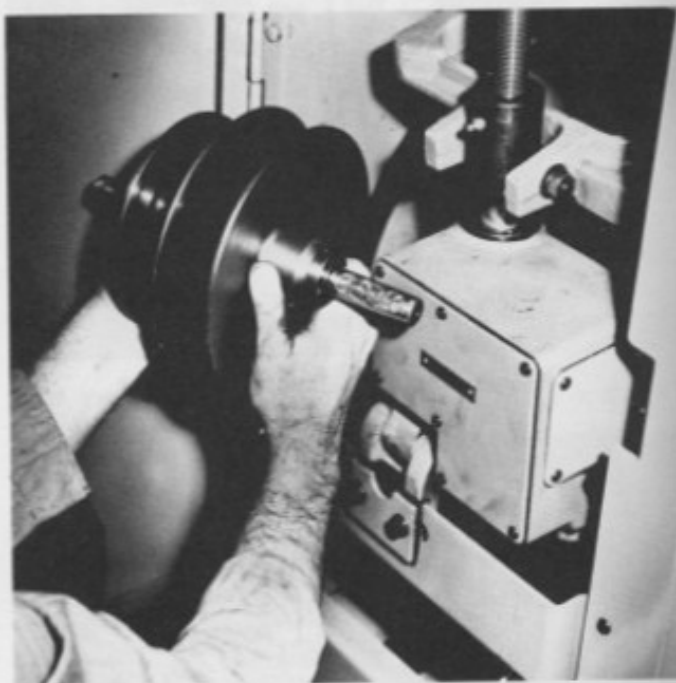
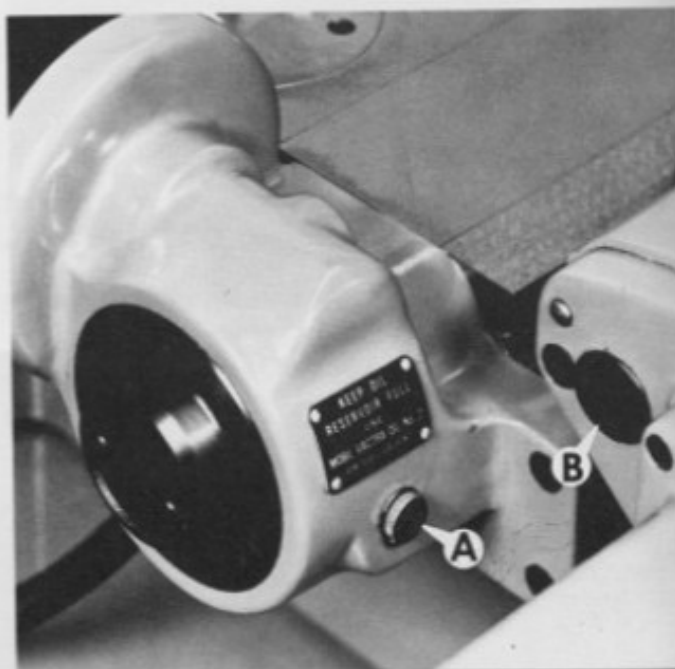

Figure 41 — Countershaft Removal

POWER FEED LUBRICATION

Lubricate power feed drive at filler cap "A", Figure 42, with Mobil Vactra Oil No. 2 or equivalent. Keep oil reservoir full. The power feed motor bearings are grease packed for life and require no further lubrication.

Figure 42 — Filler Cap for Power Feed Reservoir



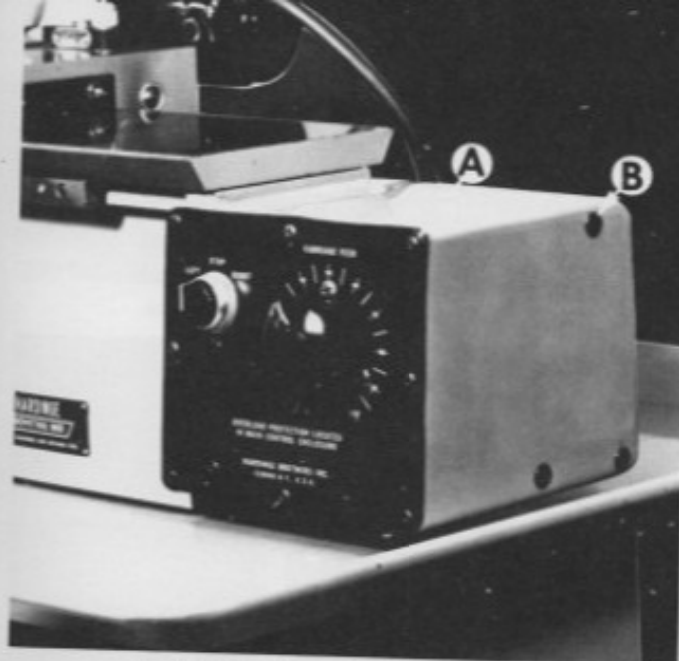

Figure 43 — Power Feed Control Panel

POWER FEED DRIVE DISASSEMBLY

1. Remove eight screws "A", Figure 43, and set power feed panel out of control box.
2. Remove four wires F1, F2, A1 and A2, Figure 44.

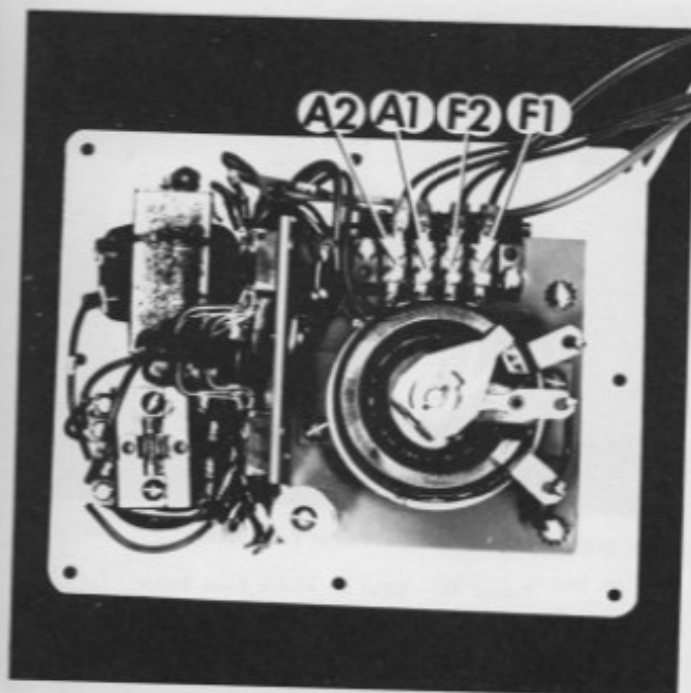

Figure 44 — Power Feed Control Panel

3. Remove three bolts "B", Figure 43.
4. Pull control box away from end of bed and remove nut "C", Figure 45, from cable grip.
5. Remove cable grip "D", Figure 46, and pull cable out through bed.
6. Remove pipe plug "E" to drain oil from power feed assembly.

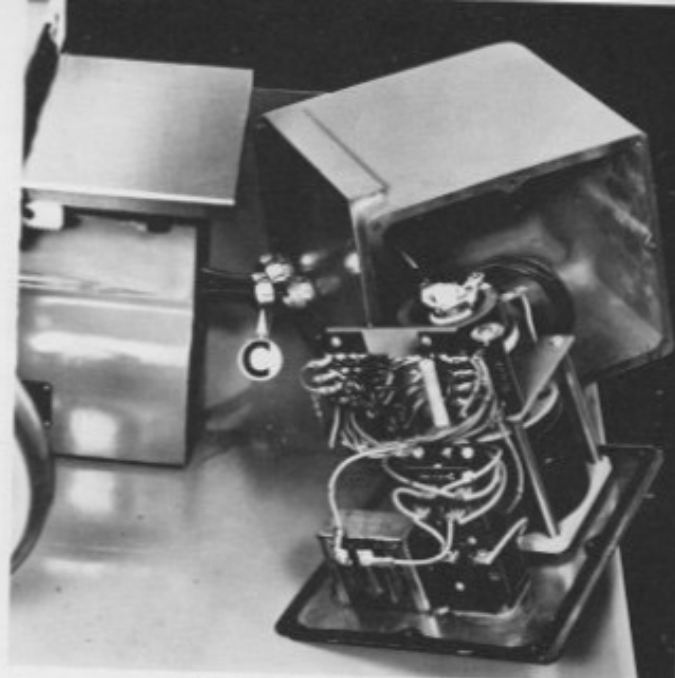

Figure 45 — Control Panel Removal

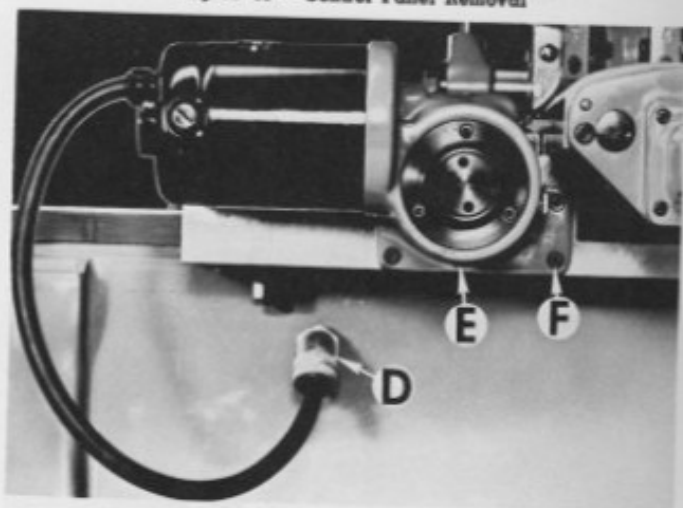
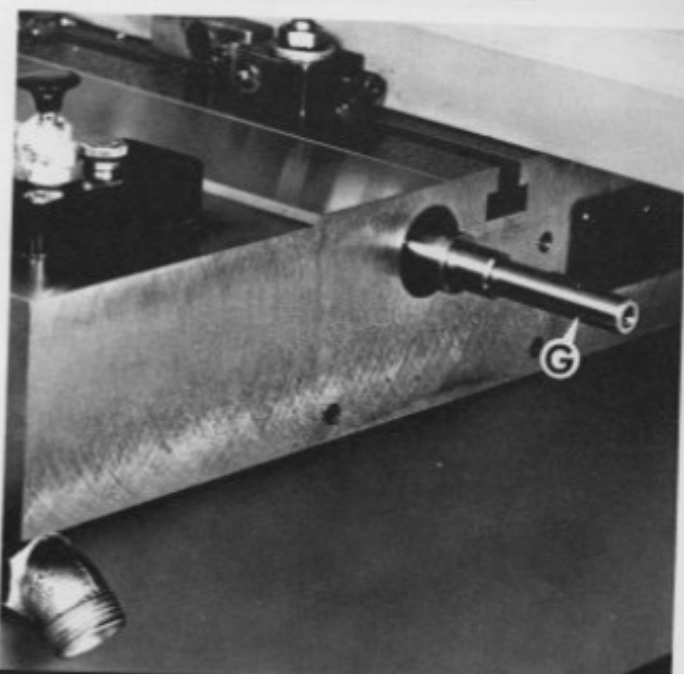

Figure 46 — Power Feed Drive

7. Remove three bolts "F" and pull power feed assembly straight off drive shaft "G", Figure 47.

Figure 47 — Power Feed Drive Shaft



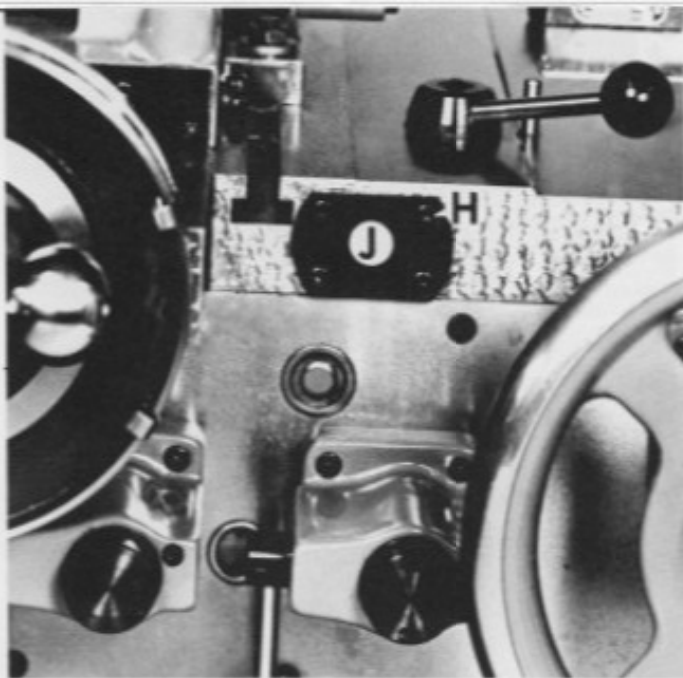
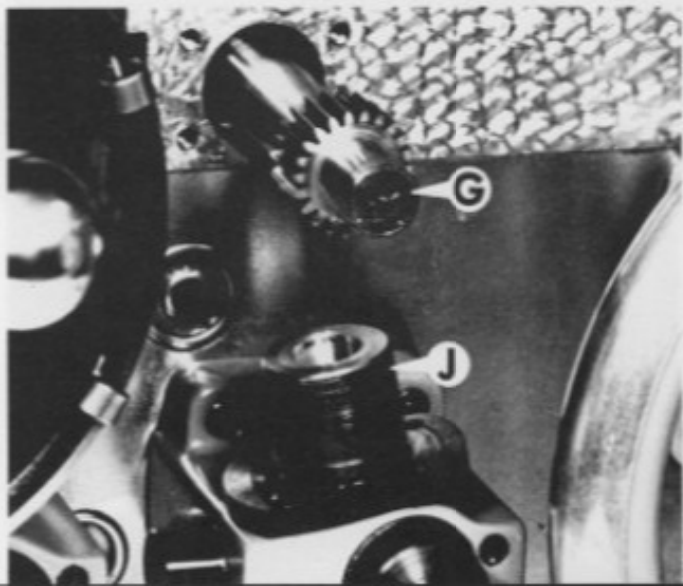

Figure 48 — Power Feed Drive Shaft Bearing

8. To remove drive shaft "G", Figure 49, remove four screws "H", Figure 48, and bearing "J". Remove drive shaft from front of machine, Figure 49.
9. Remove motor brushes under caps "K", Figure 50.
10. Remove two screws "L" and motor "M".
11. Remove screw "N" to remove motor cap, Figure 51.
12. Pull rotor shaft assembly straight out, Figure 52.
13. Remove spring pin "O" and worm "P" from rotor shaft, Figure 53.
14. Remove adjusting bushing "Q", Figure 54, with adjustable spanner wrench.
15. Remove three screws "R" and bearing support "S". Remove worm wheel "T" and bearings "U".
16. Remove adjusting bushing "V", Figure 55. Seal "W" is pressed into bushing "V".

Figure 49 — Power Feed Drive Shaft



17. When reassembling, line up center line of worm wheel "T", Figure 54, with center line of hole from which pipe plug "E", Figure 46, was removed. Adjustment is accomplished with bushings "Q" and "V". **NOTE** position of wave washer, Figure 53, which is located in motor cap. Fill reservoir with Mobil Vactra oil #2 after unit is mounted to machine.

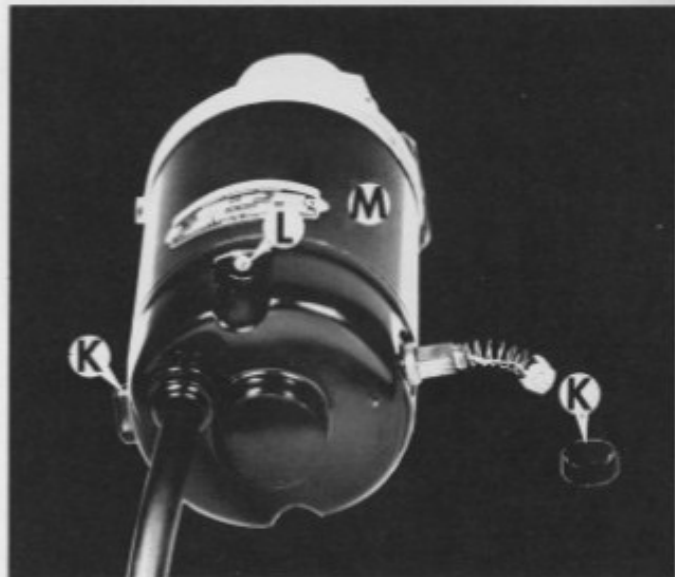

Figure 50 — Power Feed Motor and Brushes

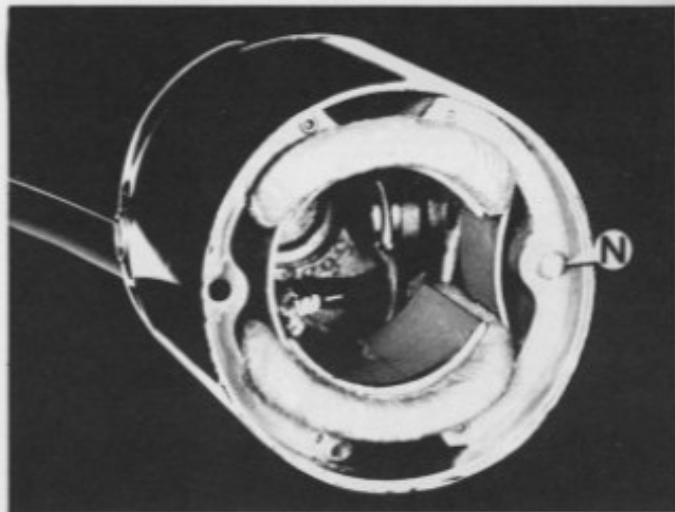

Figure 51 — Power Feed Motor

Figure 52 — Rotor for Power Feed Motor





Figure 53 — Rotor Shaft and Components

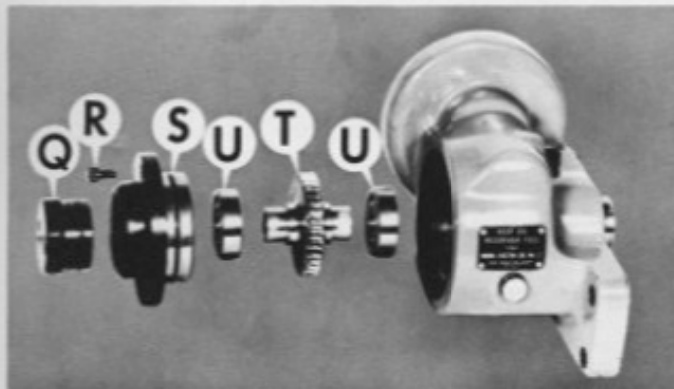

Figure 54 — Power Feed Housing and Components

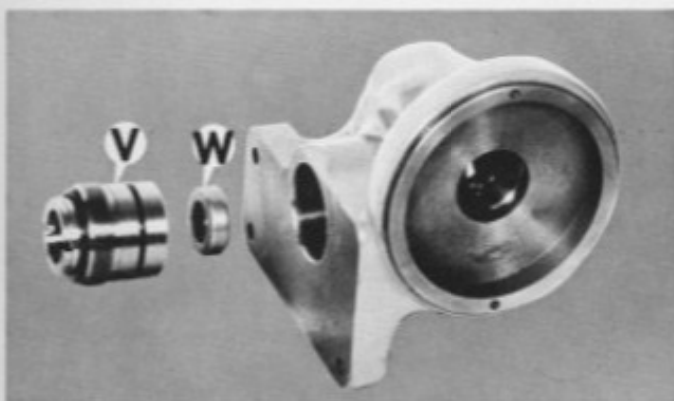

Figure 55 — Power Feed Housing and Components

POWER FEED CONTROL PANEL

The carriage feed is powered by a direct current, totally enclosed, ball bearing motor. 110 volt alternating current is fed from the main electric control panel at the left end of the pedestal to the power feed control panel at the right end of the machine. Here it is converted by silicon rectifiers to direct current for the power feed motor.

Access to the power feed control box is gained by removing eight screws "A", Figure 43.

Autotransformer "A", Figure 56, provides voltage control for armature.

Field control rheostat "B" varies voltage on field inversely to armature circuit.

Resistor "C" is switched across armature circuit when switch "F", Figure 57, is in "stop" position.

Capacitor and resistor "D" provide transient suppression.

Rectifier assembly "E", Figure 57, with silicon rectifiers provides change to DC voltage. **NOTE:** When replacing rectifiers, bleeder resistor "H" must be properly reconnected.

Switch "F" controls feed direction — left, right and stop.

Reactor "G" filters DC power supply to armature. **NOTE:** When power feed unit fails to function properly, check fuse "J", Figure 127. If fuse is blown check motor, motor leads and motor field connections.

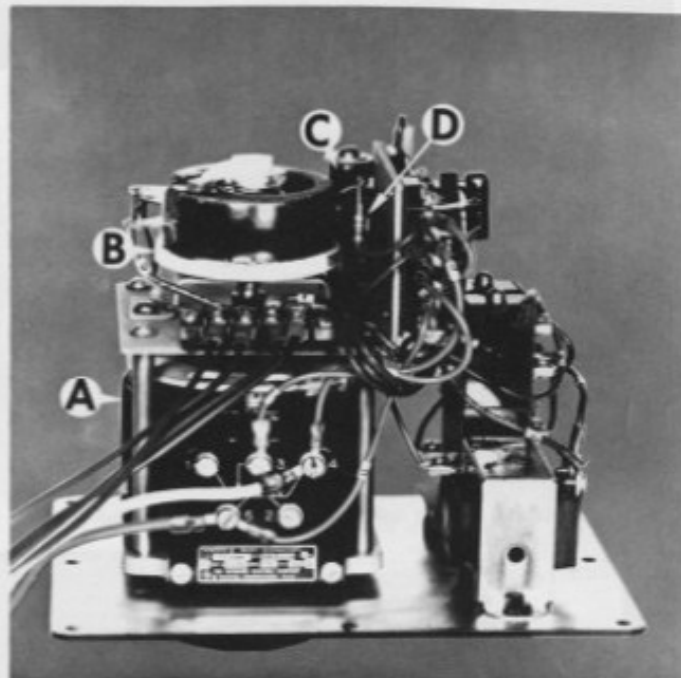
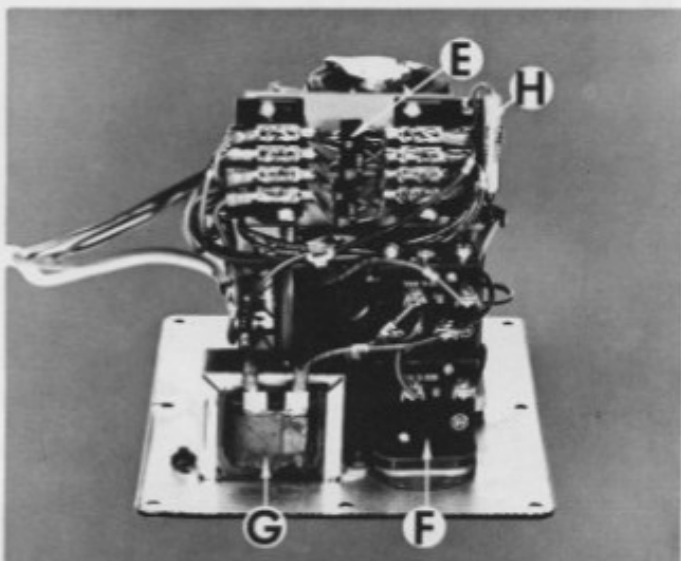

Figure 56 — Power Feed Control Panel

Figure 57 — Power Feed Control Panel



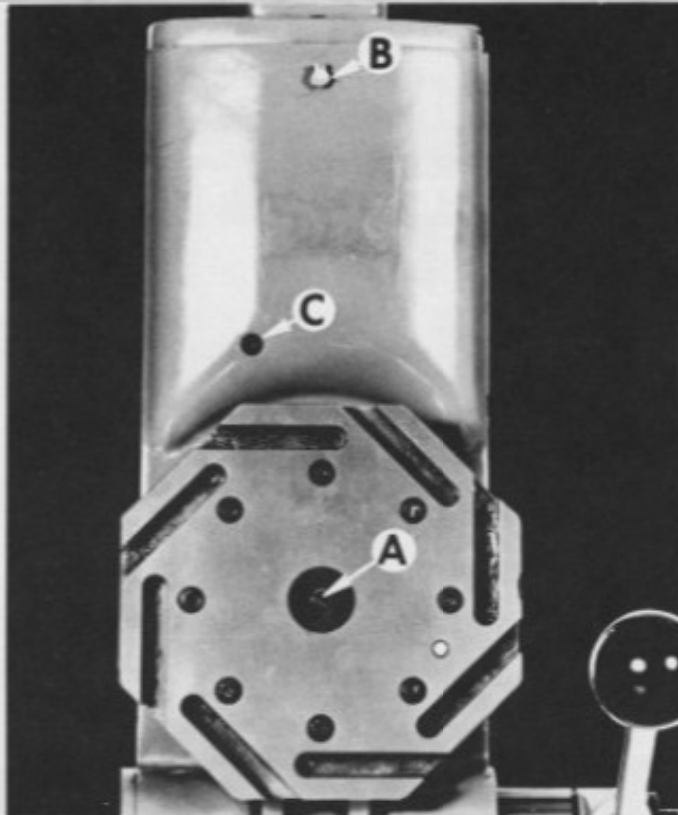

Figure 58 — Turret and Cross Slide

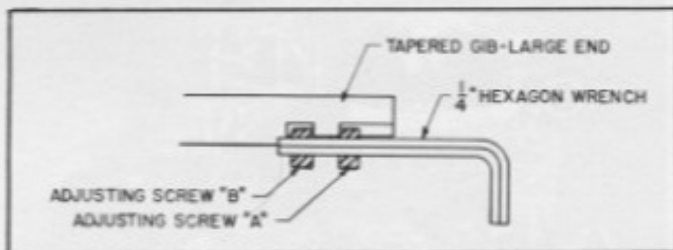
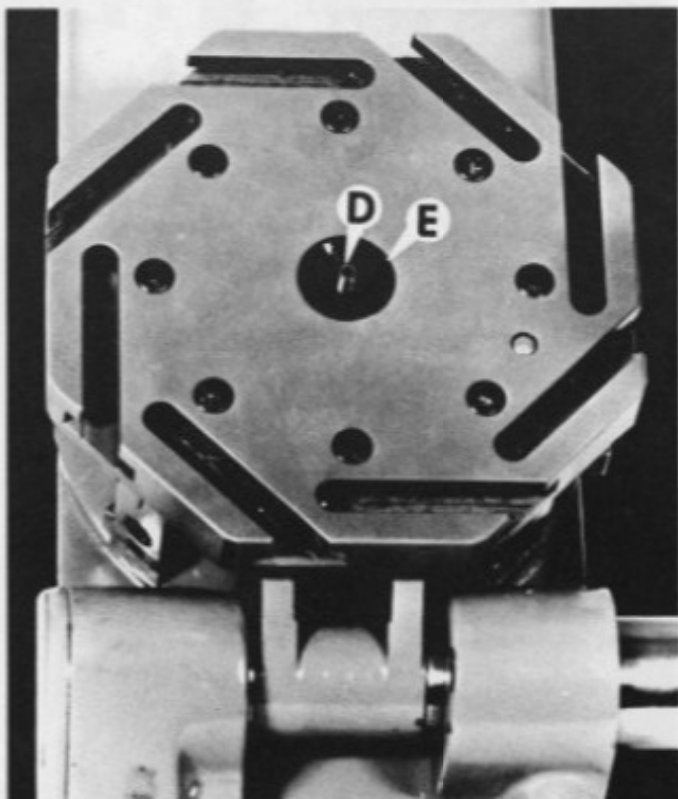

Figure 59 — Taper Gib Adjustment

Figure 60 — Plug and Lock Screw for Turret Clutch



TURRET AND CROSS SLIDE

The eight station turret is mounted on preloaded ball bearings for accuracy and absolute rigidity. The turret bearings are grease packed and sealed requiring no further attention.

TO LUBRICATE THE TURRET INDEXING MECHANISM, remove plug "A", Figure 58. Lubricate monthly with Socony Mobil G.G. Vactra Oil No. 2 or equivalent.

LUBRICATE CROSS SLIDE FEED SCREW NUT monthly at oil cup "B" with Socony Mobil G. G. Vactra Oil No. 2 or equivalent.

Remove cross slide every three months, depending on use, to clean and lubricate cross slide ways.

CROSS SLIDE REMOVAL

1. Remove chip and coolant guard if machine is so equipped.
2. Remove set screw and stop screw in tapped hole "C", Figure 58.
3. Loosen cross slide gib to allow slide to move freely.
 - (a) Remove dot plug "B", Figure 42.
 - (b) Insert $\frac{1}{4}$ " hex pin wrench in screw "A", Figure 59, and loosen one turn.
 - (c) Insert wrench on through into screw "B" and loosen one turn.
4. Remove rear cross slide stop or any other stop in use.
5. Using handwheel, feed cross slide toward rear of machine until travel stops. Pull cross slide off at rear of carriage. **HOLD GIB IN PLACE** to prevent it from dropping out.

CROSS SLIDE REPLACEMENT

1. With gib in place, start cross slide on carriage dovetail and move slowly into position while turning handwheel counterclockwise until feed screw engages feed screw nut. **CAUTION: Do not jam cross slide into position as feed screw nut may be damaged.**
2. Hand feed cross slide toward front of machine until turret has passed spindle centerline. Turn stop screw at "C", Figure 58, down until it bottoms and back off one turn. Replace set screw.
3. Readjust gib with screws "A" and "B", Figure 59. See cross slide gib adjustment, Page 19.

CROSS SLIDE GIB ADJUSTMENT

1. Remove dot plug "B", Figure 42.
2. Insert $\frac{1}{4}$ " hex pin wrench in screw "A", Figure 59, and loosen one turn.
3. Insert wrench on through into screw "B" and advance screw "B" a fraction of a turn.
4. Pull wrench out of "B" and tighten "A" until snug. **Do not overtighten.**
5. Test cross slide for "feel" — the cross slide should have a slight drag, but should not bind.

NOTE: Excessive gib pressure or drag does not improve machine performance.

TURRET DISASSEMBLY

1. Follow steps 1 through 5 under "Cross Slide Removal", Page 18.
2. Remove plug "A", Figure 58.
3. Using $\frac{1}{8}$ " pin wrench remove lock screw "D", Figure 60, which is located directly under plug "A".
4. Remove lock plug "E" and O-ring.
5. Remove clutch assembly from bottom of cross slide, Figure 61.
6. Remove gear "F", Figure 62, to disassemble clutch. Use care so as not to lose pins "G" or springs "H".
7. If necessary, remove stud "J", Figure 63, to remove gear "K".

NOTE: Before proceeding beyond this point it should be noted that the **original accuracy of the turret cannot be guaranteed after removal of preloaded ball bearings.** Should original accuracy be required, turret and cross slide assembly should be returned to Hardinge for necessary repairs.

Figure 61 — Turret Clutch Removal

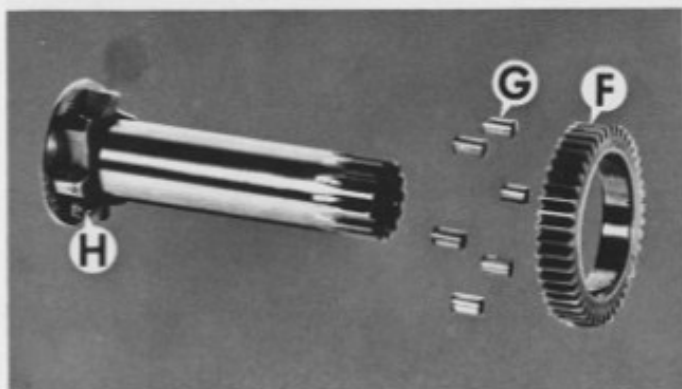
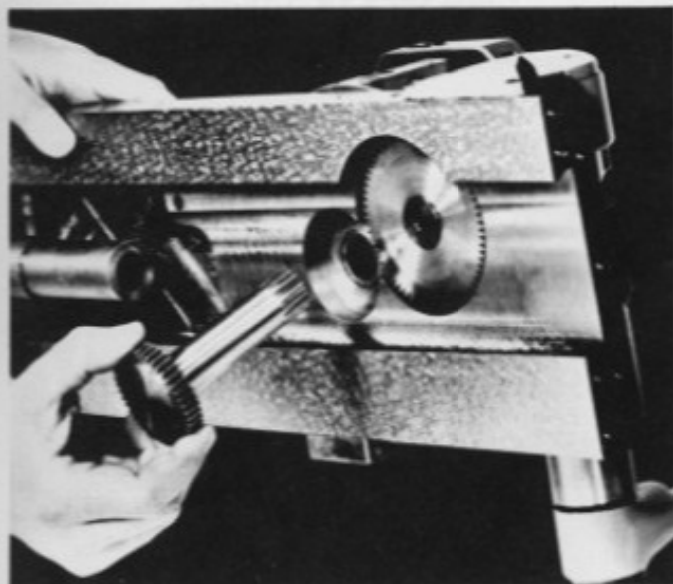

Figure 62 — Turret Clutch

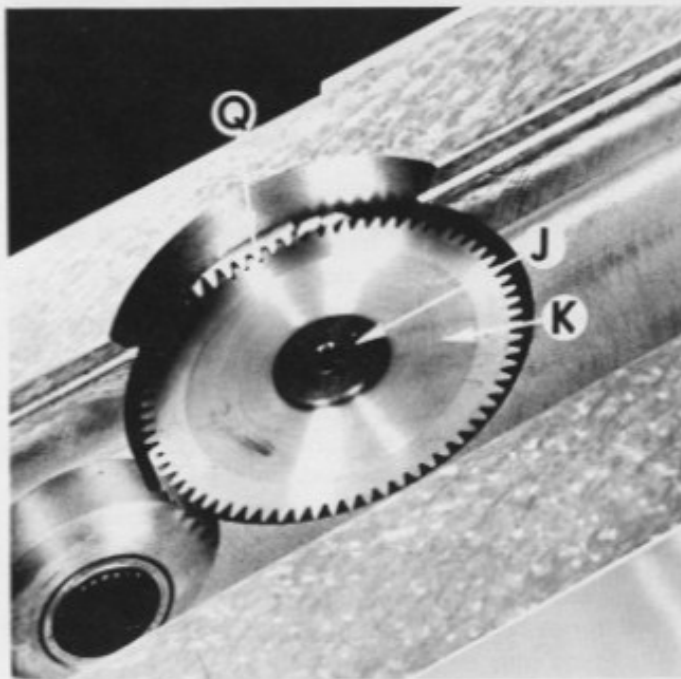
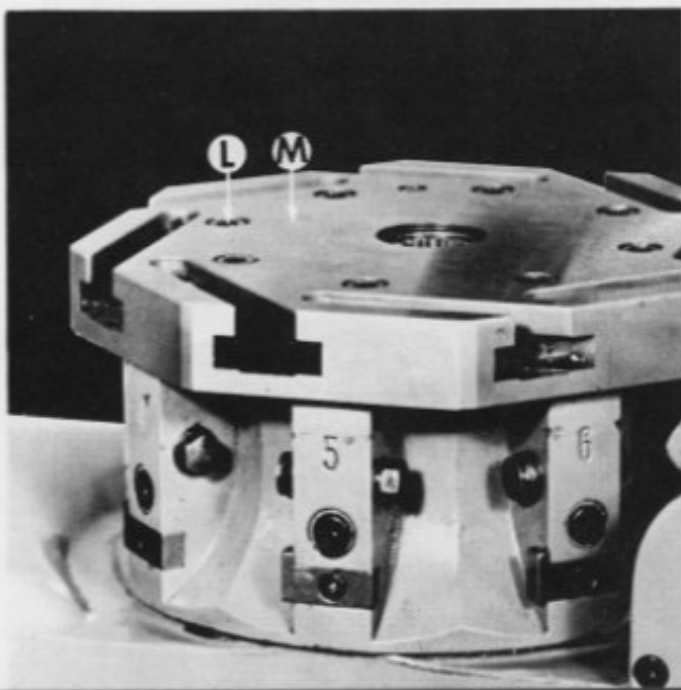

Figure 63 — Turret Rack and Gear

8. Remove eight screws "L", Figure 64, and top plate "M".

Figure 64 — Turret Top Plate



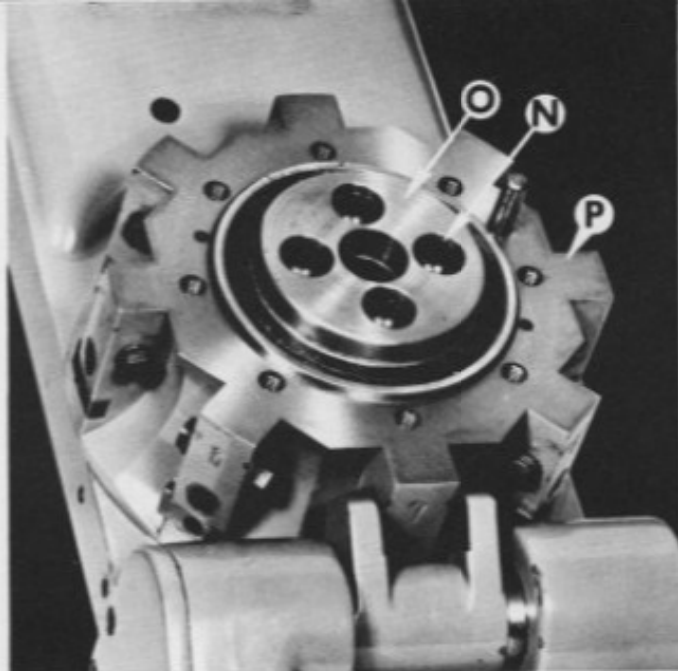

Figure 65 — Retaining Plate for Turret

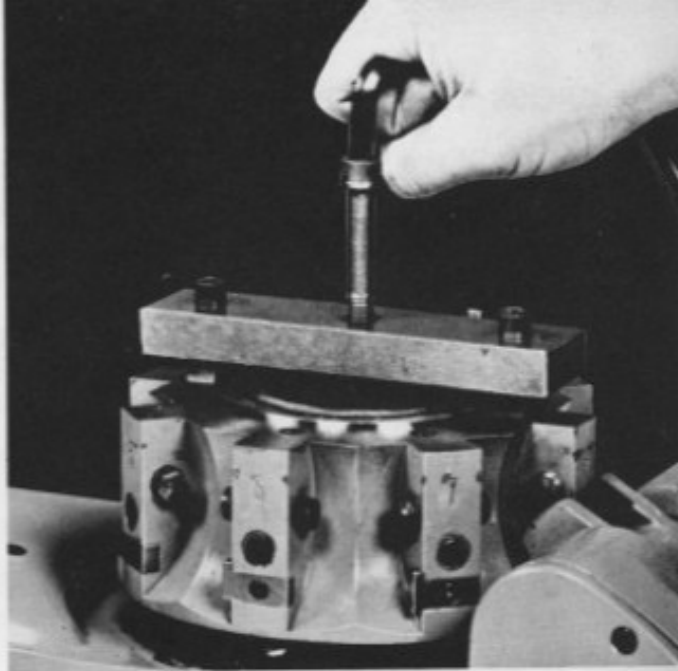

Figure 67 — Turret Body Removal

9. Remove four screws "N", Figure 65, and retaining plate "O".
10. Remove turret body "P". It will be necessary to contrive some sort of puller arrangement as shown, Figures 66 and 67.
11. Ball "Q", Figure 68, spring "R" and sealing ring "S" can now be removed. Remove bearing shield "T", Figure 69.
12. Knockout holes have been provided for bearing removal. If lower bearing "U" remains with turret body, remove bearing by alternately tapping pins as shown, Figure 70. If lower bearing remains with cross slide base, remove bearing by alternately tapping pins as shown, Figure 71. Remove spacer "V", Figure 69.
13. Remove top bearing "W" by alternately tapping pins as shown, Figure 72.

Figure 66 — Puller Arrangement for Turret Body

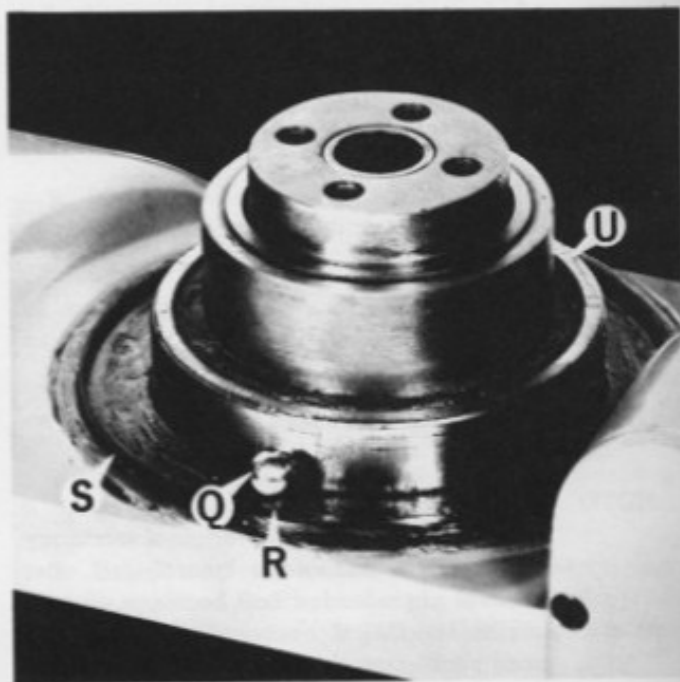
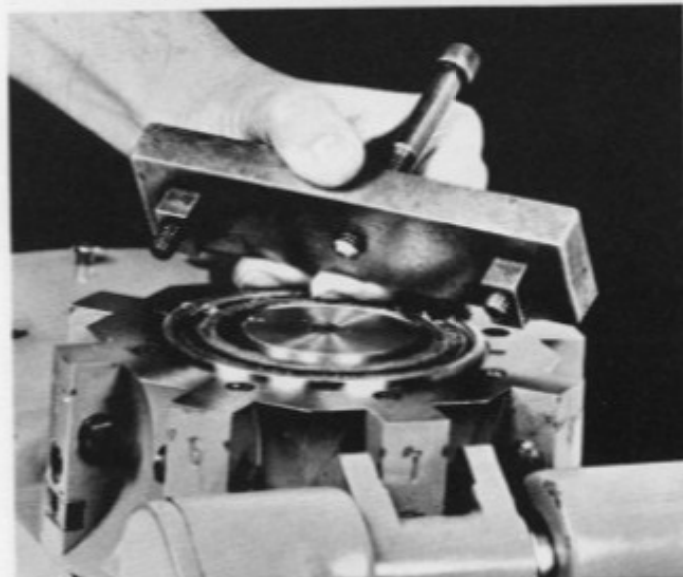
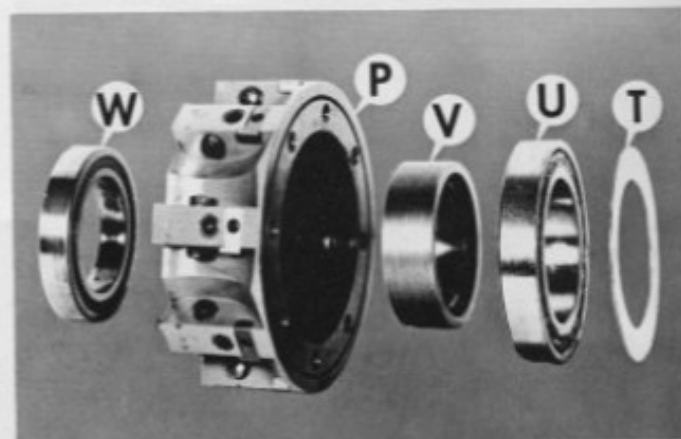

Figure 68 — Post for Turret and Components

Figure 69 — Turret Body and Components



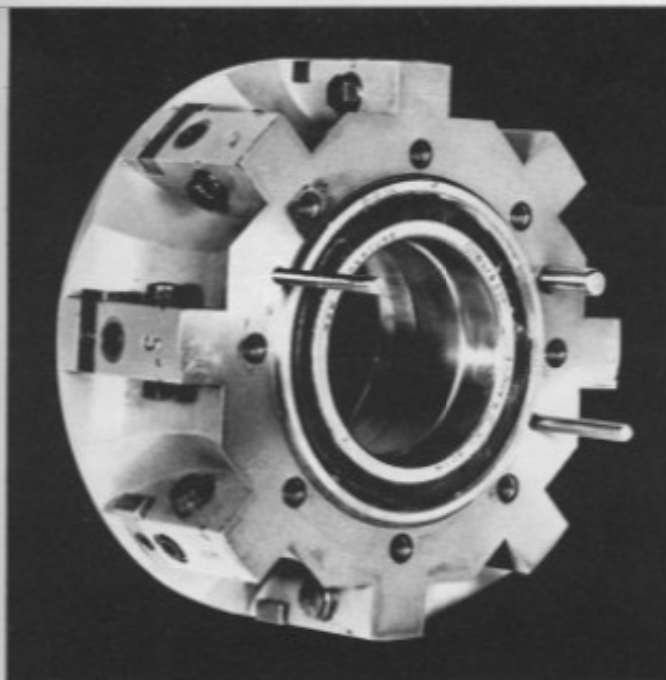

Figure 70 — Knockout Holes for Lower Bearing

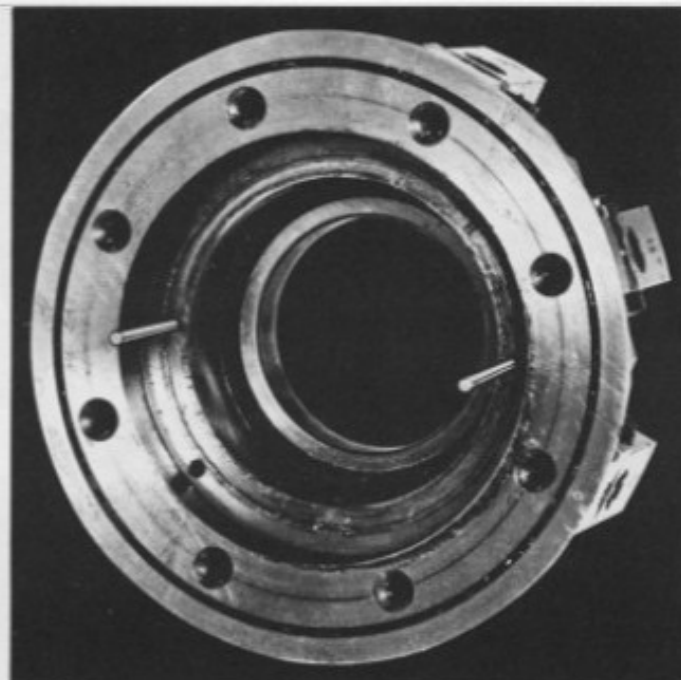

Figure 72 — Knockout Holes for Upper Bearing

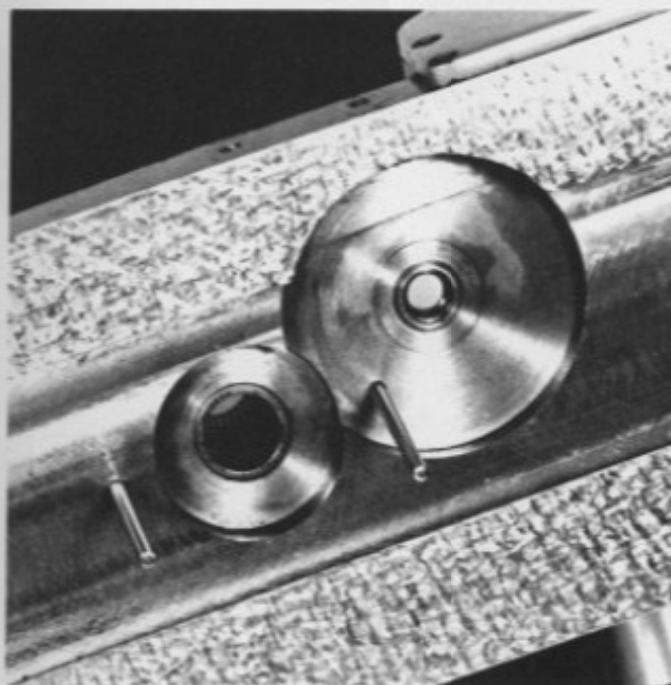

Figure 71 — Knockout Holes for Lower Bearing

TURRET REASSEMBLY

1. Replace ring "S", Figure 68, spring "R" and ball "Q". Pack ring and spring and grease ball with Shell Alvania #3 grease.
2. Replace bearing "U", Figure 69, in body "P". Line up marks indicating bearing high points on inner and outer races with station number one on body. (Open side of bearing faces out.) Replace bearing shield "T".
3. Replace body "P" on cross slide post.
4. Replace spacer "V" and bearing "W". Line up marks indicating bearing high points on inner and outer races with station number one on body. (Open side of bearing faces out.)

5. Replace retaining plate "O", Figure 65, and four screws "N". Tighten screws "N" with torque wrench to 200 inch pounds.
6. Replace top plate "M", Figure 64, and eight screws "L". Permatex seal screws "L".
7. Replace gear "K" and stud "J", Figure 63.
8. Replace gear "F", Figure 62, on clutch shaft. Pins "G" are easily replaced by compressing springs "H" with a small wire.
9. Replace clutch assembly in turret, Figure 61.
10. Assemble lock plug "E" and O-ring, Figure 60. Tighten plug "E" until snug and back off 1/2 turn. Tap head of plug down to seat in counterbore of top plate.
11. Replace set screw "D" and tighten securely.
12. Follow steps 1 through 3 under "Cross Slide Replacement", Page 18.
13. Lubricate turret indexing mechanism as per instructions, Page 18.
14. Replace plug "A" and O-ring, Figure 58.

TO DISASSEMBLE INDEX LEVER AND LOCK ASSEMBLY

1. Follow steps 1 through 5 under "Turret Disassembly", Page 19.
2. Remove seven screws "A", Figure 73, and three wipers "B", "C" and "D".

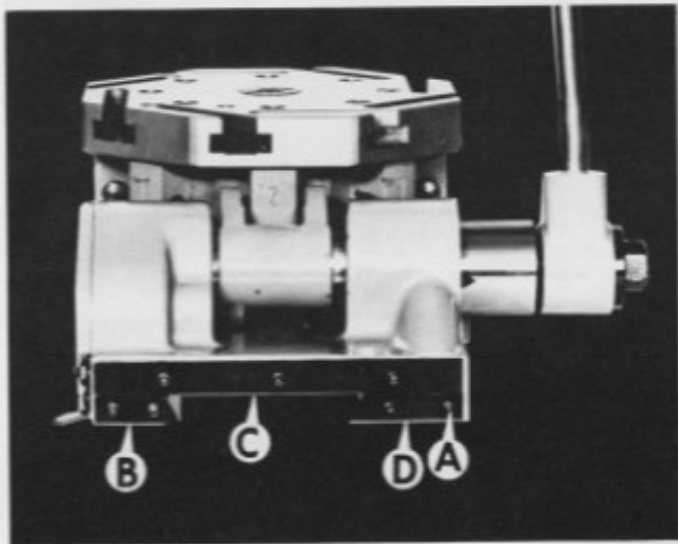

Figure 73 — Doves-tail Wipers for Cross Slide

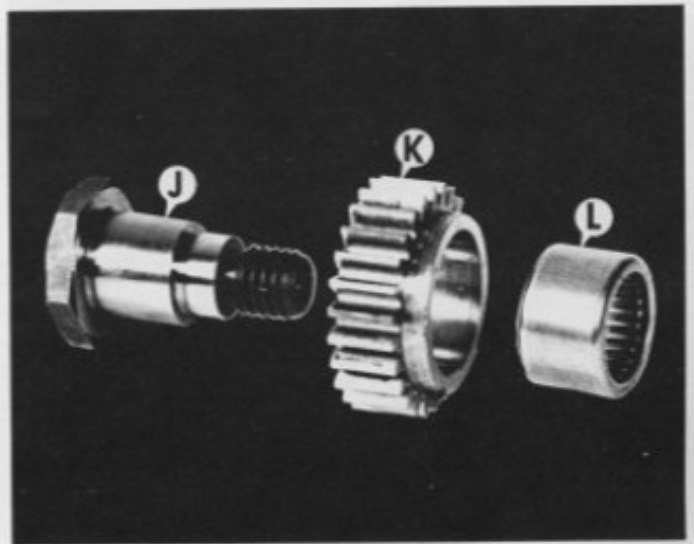

Figure 76 — Rack Gear, Stud and Bearing

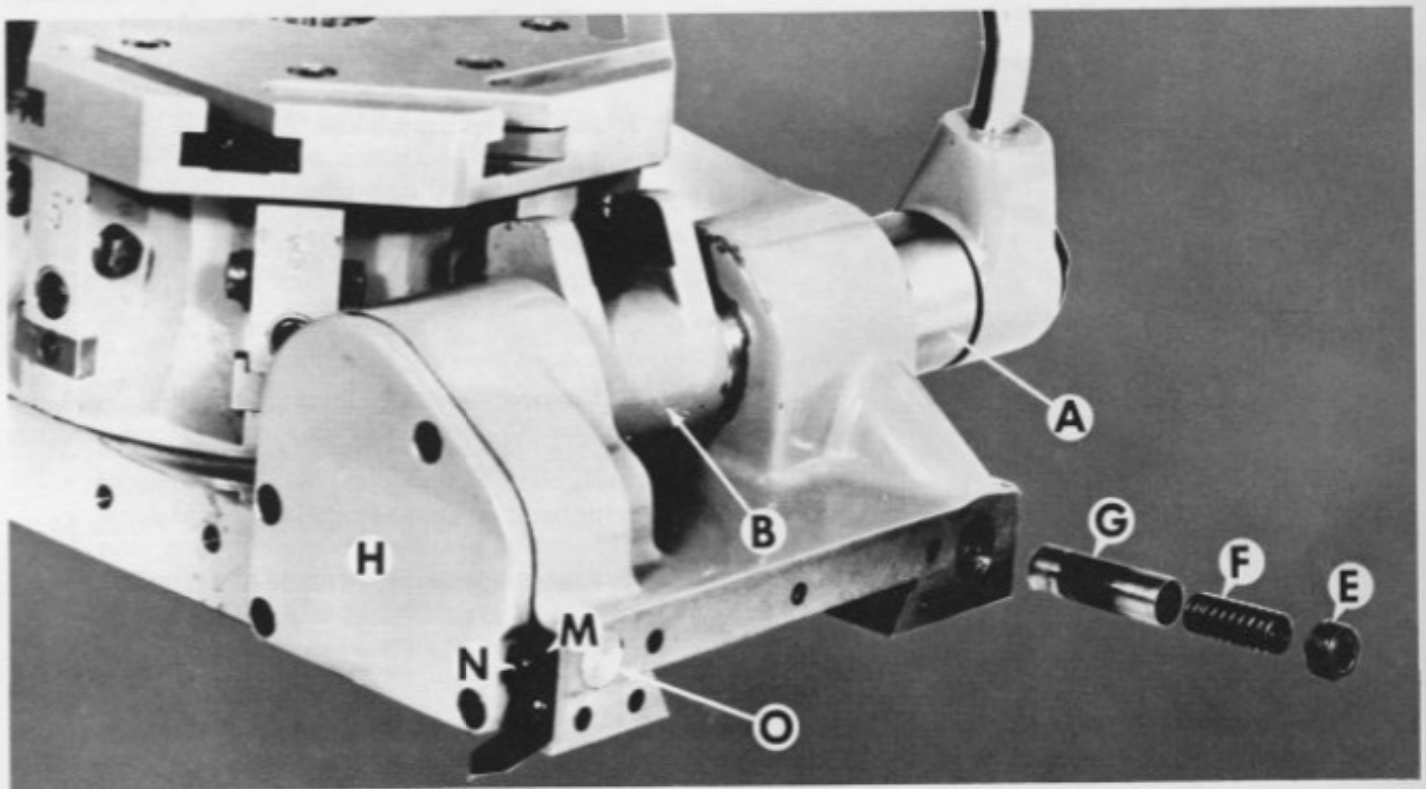
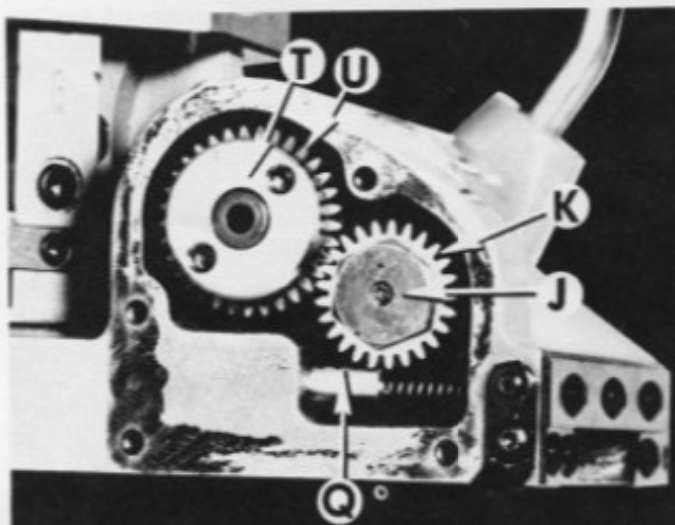

Figure 74 — Index Lever and Lock Assembly

Figure 75 — Turret Indexing Gears and Rack



3. Remove plug "E", Figure 74, spring "F" and plunger "G".
4. Remove cover "H", Figure 74.
5. Remove stud "J" and gear "K", Figure 75. Bearing "L", Figure 76, is pressed into gear "K".
6. Loosen nut "M", Figure 74, and remove screw "N".
7. Remove plug "O", Figure 74, spring "P", Figure 77, and rack "Q". Do not disturb adjusting screw "S" which determines rack travel.
8. Remove nut "T", Figure 75, and gear "U", bushing "V", Figure 78, bearing "W" and spacer "X".

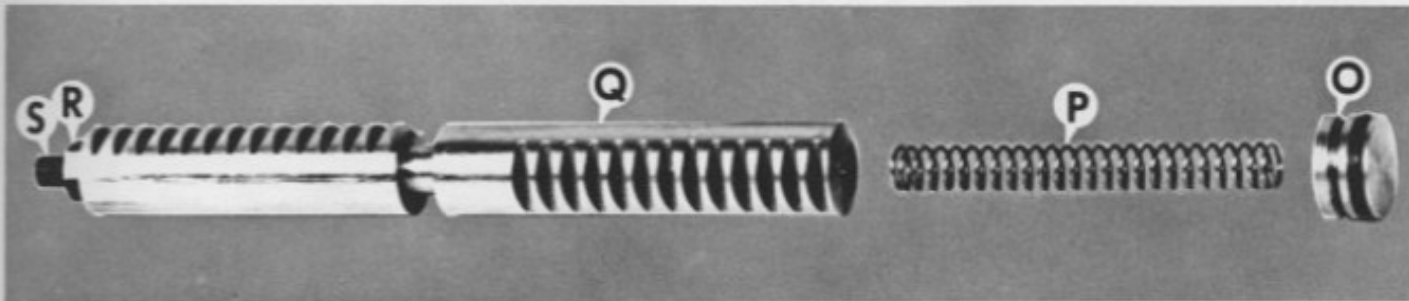

Figure 77 — Turret Rack and Components

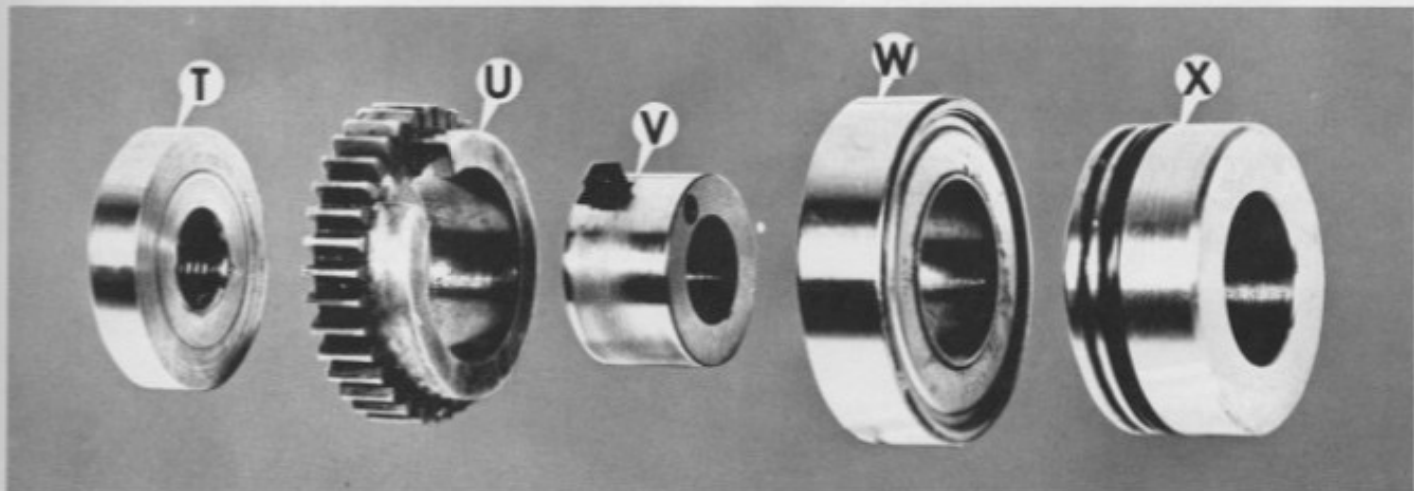

Figure 78 — Turret Indexing Shaft Components

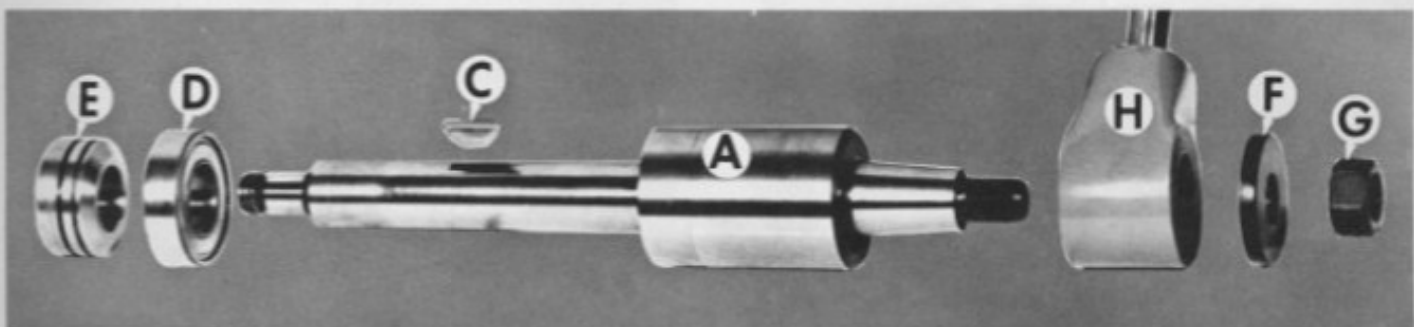

Figure 79 — Turret Indexing Shaft and Components

9. Remove index shaft "A", Figure 74, and fork "B". Use pointed punch in center drilled hole to remove shaft "A".
10. Remove key "C", Figure 79, to remove bearing "D" and spacer "E".
11. Remove nut "G" and washer "F" to remove handle "H". Rap handle at casting with plastic hammer to loosen taper lock.

TO REASSEMBLE INDEX LEVER AND LOCK ASSEMBLY

1. Replace bearing "D", spacer "E" and key "C" on shaft "A", Figure 79.
2. Coat O.D. and notches of shaft at points "A", Figure 80, with molylube. Also coat O.D. of spacer "E", Figure 79, with molylube.
3. Position fork "B", Figure 74, and replace shaft "A".
4. Assemble nut "G", Figure 79, washer "F" and handle "H" on shaft "A".
5. Coat O.D. of spacer "X", Figure 78, and bushing "V" with molylube. Replace spacer and O-ring "X", bearing "W", bushing "V" and gear "U".
6. Replace nut "T", Figure 75, and tighten to 250 inch pounds torque.
7. Coat rack "Q", Figure 77, with Mobil Vactra Oil #2 or equivalent. Replace rack "Q", spring "P", plug "O", screw "N", Figure 74, and lock nut "M". **NOTE:** If adjusting screw "S", Figure 77, has been disturbed, it will be necessary to adjust screw "S" to limit rack travel to a point short of where teeth on gear "K", Figure 63, would hit non-toothed section of rack "Q".

- Coat plunger "G", Figure 74, with Mobil Vactra Oil #2 or equivalent. Replace plunger "G", spring "F" and plug "E". Thread plug "E" in until index lever will not operate and back out until lock fork clears for indexing and 1/3 turn more.
- With rack "Q", Figure 75, at full travel, index lever in locked position and gear "U" turned to right, assemble stud "J" and bearing and gear "K". Should gear "K" fail to mesh or fork fail to lock securely in all stations, adjust screw "S", Figure 77.
- Coat gears with Mobil Vactra Oil #2 or equivalent. Permatex seal and replace cover "H", Figure 74.
- Follow steps 9 through 14 under "Turret Re-assembly", Page 21.
- Replace wipers "B", "C" and "D", Figure 73. Set wipers .0015" above dovetail surfaces.

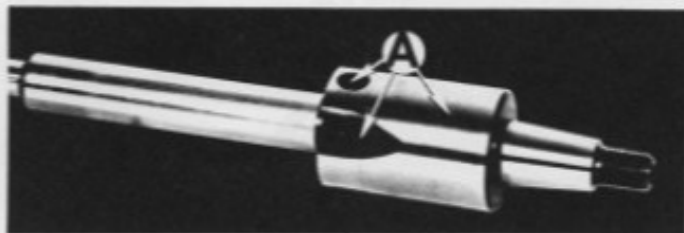

Figure 80 — Indexing Shaft Lubricant Points

CROSS SLIDE FEED SCREW NUT REMOVAL

- Follow steps 1 through 5 under "Cross Slide Removal", Page 18.
- Remove four screws "A", Figure 81, and cover "B".
- Remove nut "C", Figure 82, with adjustable spanner wrench.
- Remove half nut "D" which is threaded into housing "E".
- Remove screw "F", Figure 83, to remove half nut "G".

CROSS SLIDE FEED SCREW NUT REPLACEMENT

- Replace half nut "G", Figure 83, and screw "F".
- Replace half nut "D".
- Follow steps 1 through 3 under "Cross Slide Replacement", Page 18.
- Adjust half nut "D" in for minimum backlash (maximum of two graduations on feed screw dial).
- Replace nut "C". Hold half nut "D" and tighten nut "C" securely.
- Replace cover "B".

CROSS SLIDE FEED SCREW NUT ADJUSTMENT

- Remove four screws "A", Figure 81, and cover "B".
- Loosen nut "C", Figure 82, with adjustable spanner wrench.
- Adjust half nut "D" in for minimum backlash (maximum of two graduations on feed screw dial.)
- Hold half nut "D" and tighten nut "C" securely.
- Replace cover "B".

CARRIAGE GIB ADJUSTMENT

After considerable use it may be necessary to adjust the carriage gib "C", Figure 84. The gib is the tapered type and adjustment is made from the large end shown in Figure 84.

- Insert 1/4" hexagon wrench in adjusting screw "A", Figure 84, and Figure 59. Loosen one full turn.
- Push wrench on through into adjusting screw "B", Figure 59. Advance adjusting screw "B" a fraction of a turn.
- Pull wrench out of "B" and tighten "A" until snug. Do not overtighten.
- Test carriage for "feel" — the carriage should have a slight drag but should not bind.

NOTE: Excessive gib pressure or drag does not improve machine performance.

CARRIAGE LUBRICATION

Keep oil reservoir "D", Figure 84, full with Mobil Vactra Oil #2 or equivalent. Maintain oil level in sight window "E". To lubricate carriage and bed ways, lift plunger, **HOLD BRIEFLY AND RELEASE, ALLOWING PLUNGER TO RETURN OF ITS OWN ACCORD.** Operate pressure oiler as often as required to keep bed ways wet or a minimum of once daily. Should it be necessary to remove lubricator to clean well, remove four screws "A", Figure 86.

Use pressure oil can to lubricate carriage gear rack with light oil weekly.

CLUTCH AND GEAR BOX LUBRICATION

Keep oil in apron assembly in sight window "F", Figure 85. Add oil by removing cap "G", Figure 84. Use automatic transmission fluid — Mobilfluid 350 or equivalent. **CHANGE OIL EVERY 60 DAYS.** To drain oil remove magnetic drain plug "H", Figure 85.

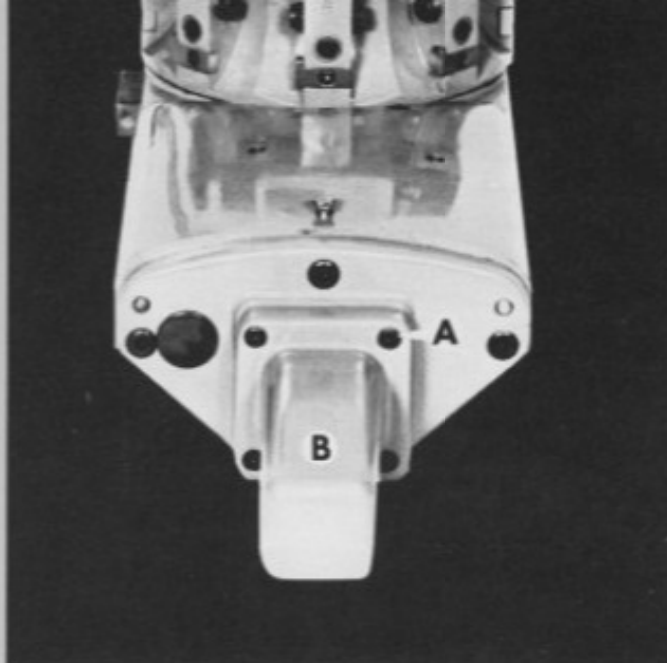

Figure 81 — Cover for Cross Feed Screw Nut

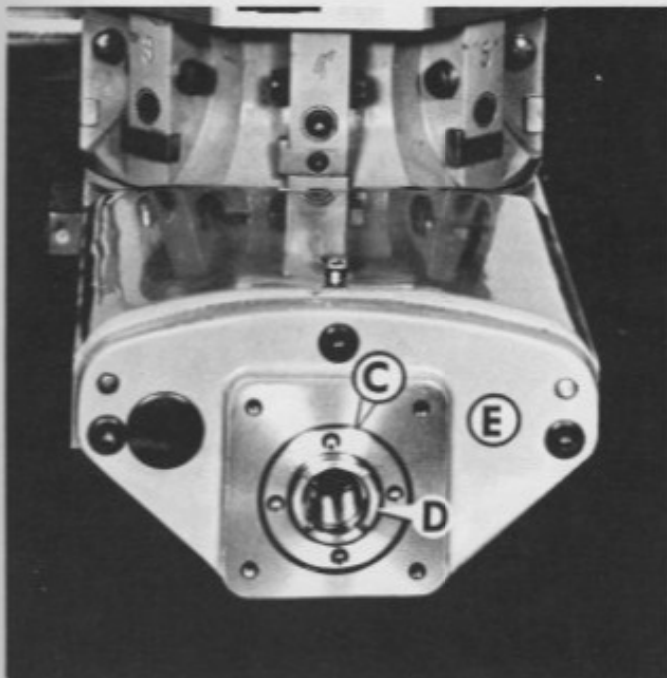

Figure 82 — Cross Feed Screw Nut

Figure 83 — Cross Feed Screw Nut Components

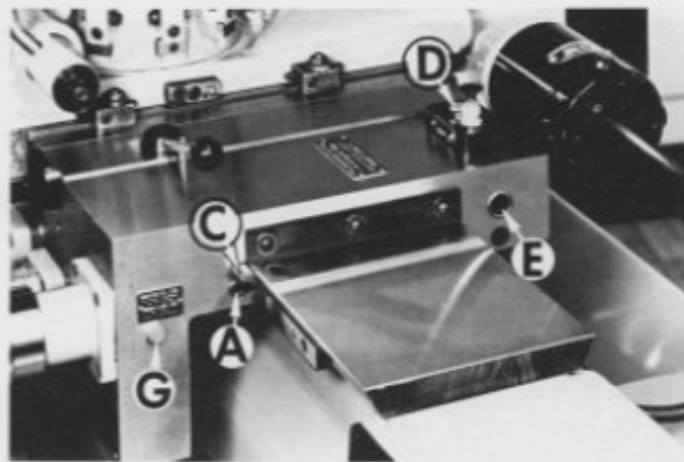
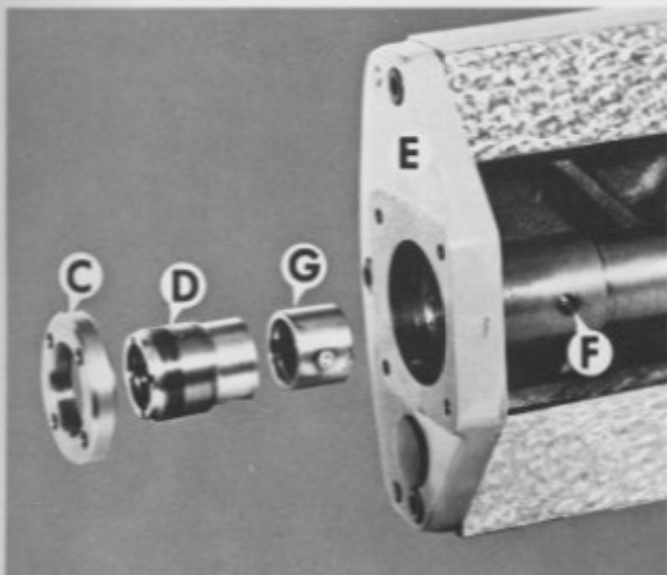

Figure 84

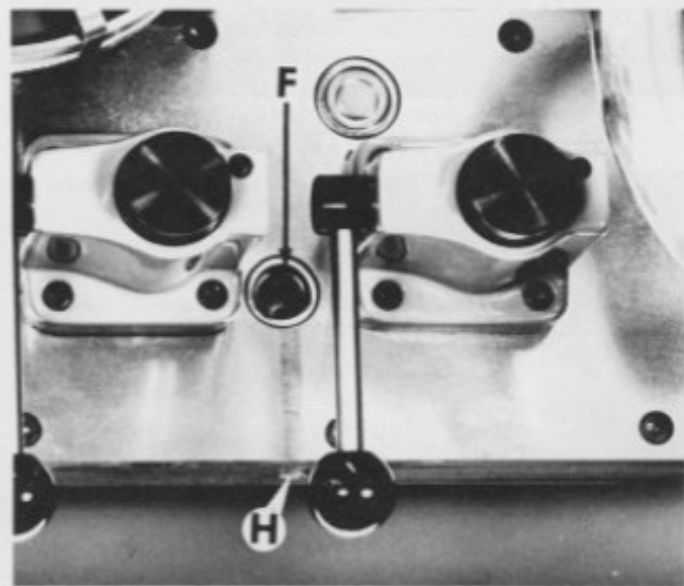
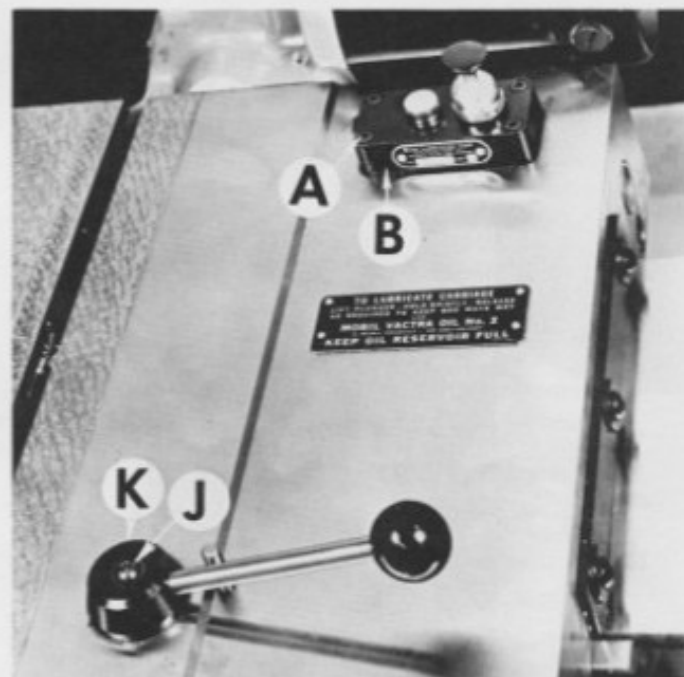

Figure 85 — Lubricant Sight Window and Drain Plug

Figure 86 — Carriage Lubricator and Lock



CARRIAGE LOCK REMOVAL

1. Remove screw "J" and washer, Figure 86.
2. Lift handle and hub "K" off.
3. Unscrew lock bolt "L", Figure 87, from lock plug "M".
4. To reassemble locate plug "M" in socket in carriage with flat side toward bed way.
5. Thread lock bolt "L" into plug "M".
6. Replace hub "K", Figure 86.
7. Lock is in released position as shown, Figure 86, and should lock from 60° to 90° from pin. If this is not the case, remove hub and tighten or loosen lock bolt "L".
8. When lock functions properly, assemble washer and screw "J", Figure 86.

CARRIAGE DISASSEMBLY

Note: For carriage removal and replacement, see Page 40.

1. Drain oil at plug "H", Figure 85.
2. Remove four screws "A", Figure 88, and remove longitudinal handwheel, Figure 89.
3. Remove eight screws "B", Figure 88, and clutch housings.
4. Remove two screws "C" and cover "D", Figure 90. Do not misplace seal under cover "D".
5. Remove nine screws "E", Figure 88.
6. The apron cover is Permatex sealed. To remove cover, pull with left hand while striking cover with plastic mallet as shown in Figure 91. When crack in sealer appears, rap cover back in place. Repeat procedure working cover back and forth until seal is broken and cover can be removed.
7. Remove nut "A", Figure 92. **CAUTION:** Spring is under tension. Clutch parts with the exception of springs are identical on front side of cover. **DO NOT INTERCHANGE SPRINGS.**
8. Remove bearing "B", Figure 93, washer "C", spring "D", spring seat "E" and spacer "F".
9. Remove nut "G" to remove clutch assembly, Figure 94.
10. To disassemble longitudinal clutch:
 - (a) Remove snap ring "A", Figure 95.
 - (b) Remove 70 tooth gear "B", Figure 96, and clutch plate "C".

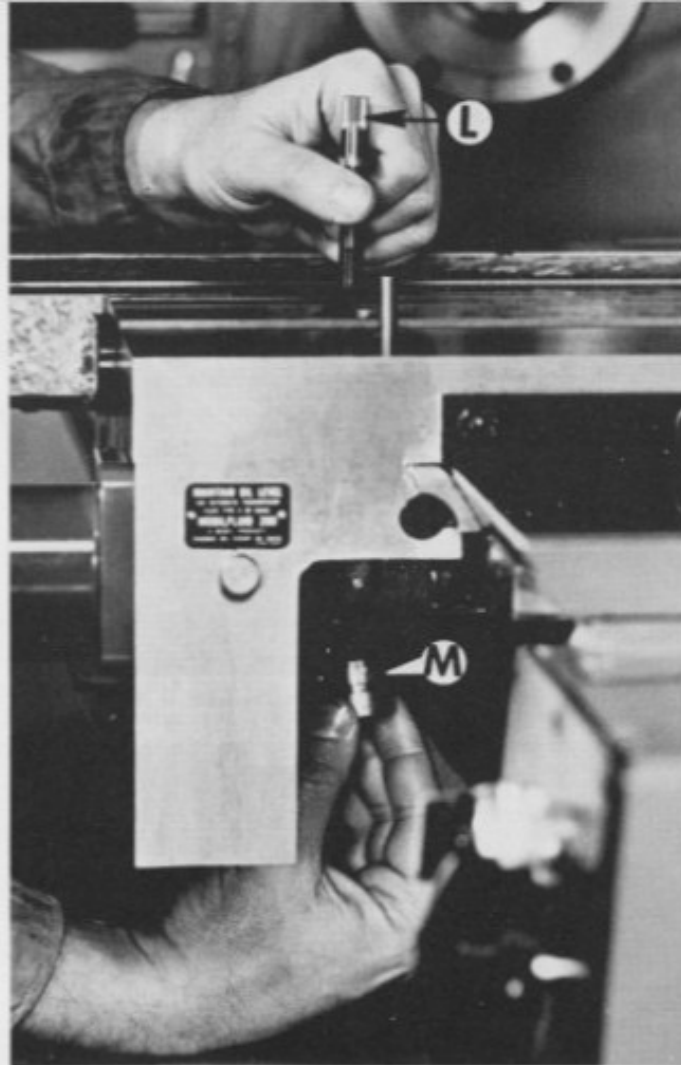

Figure 87 — Carriage Lock Removal

Figure 88 — Carriage Clutches and Handwheel

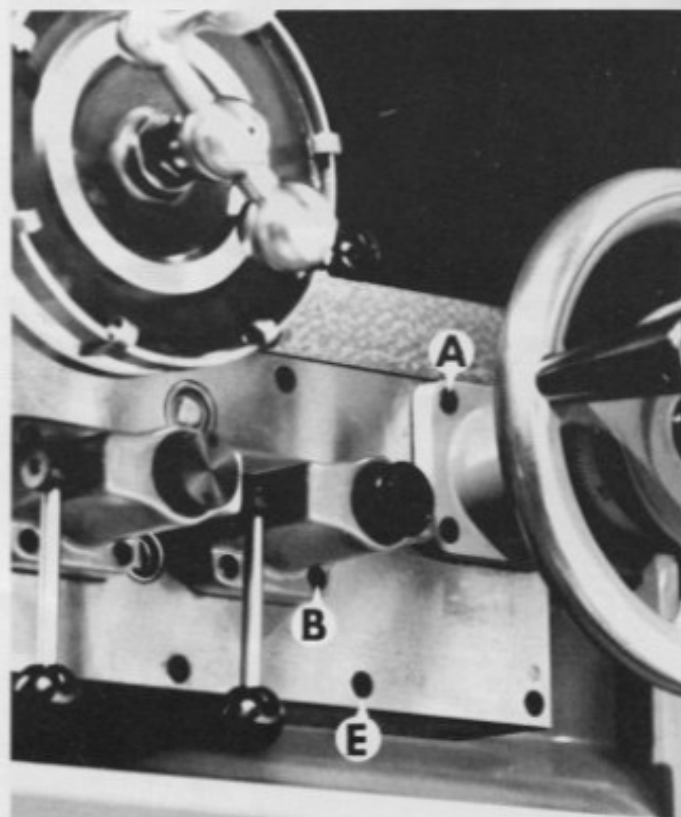



Figure 89 — Carriage Handwheel Removal

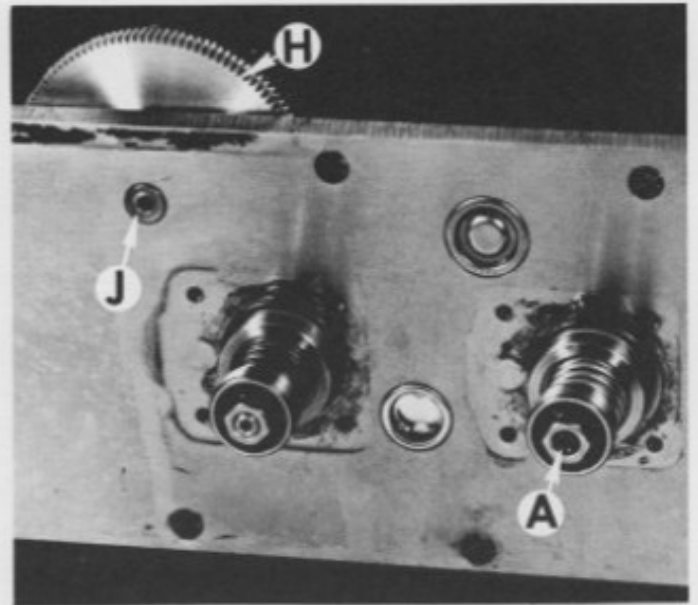

Figure 92 — Apron Cover and Clutches

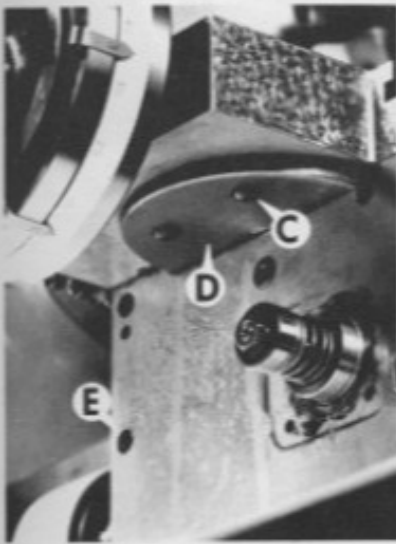

Figure 90 — Carriage Cover

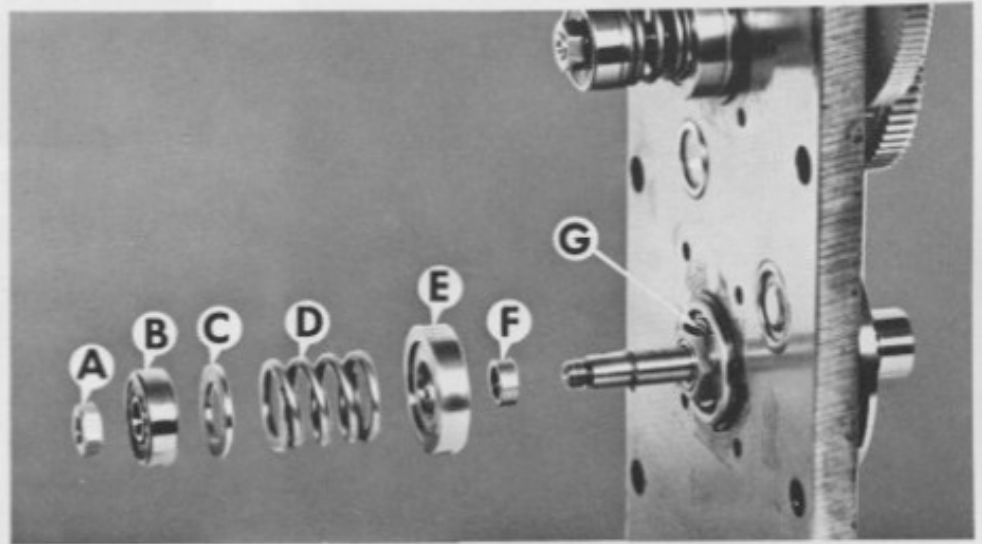

Figure 93 — Power Feed Clutch Components

Figure 91 — Apron Cover Removal

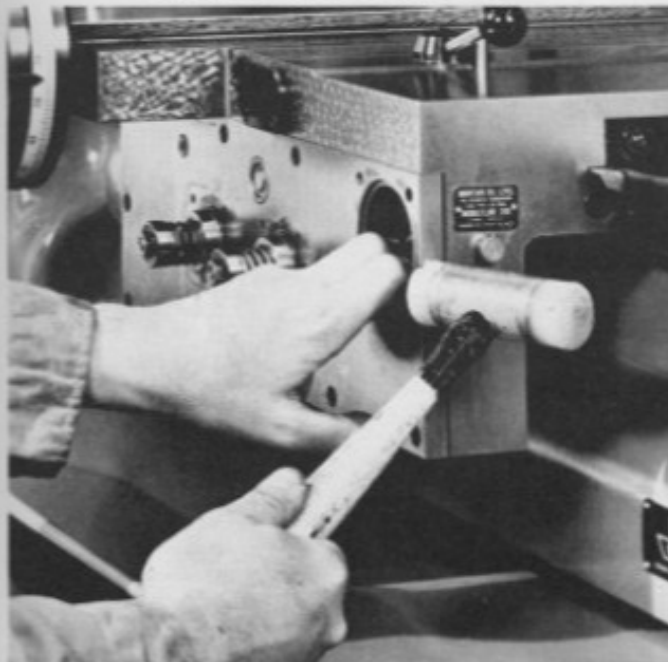
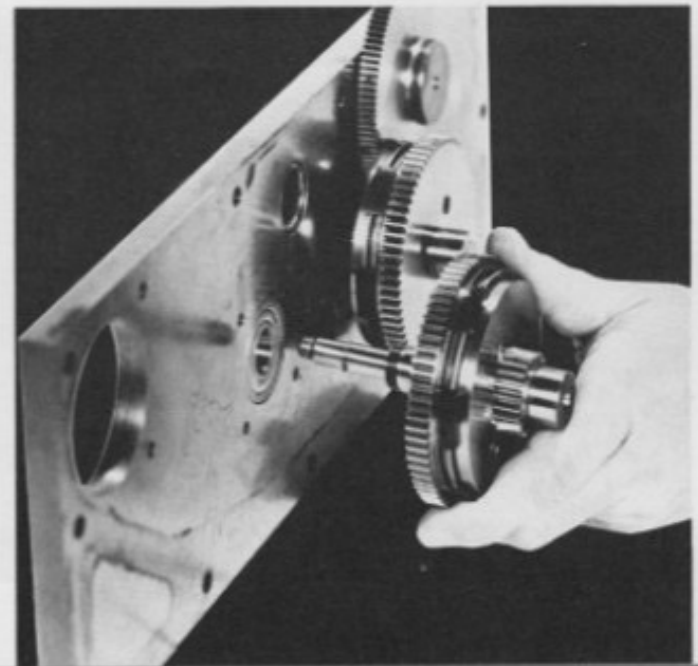

Figure 94 — Power Feed Clutch Removal



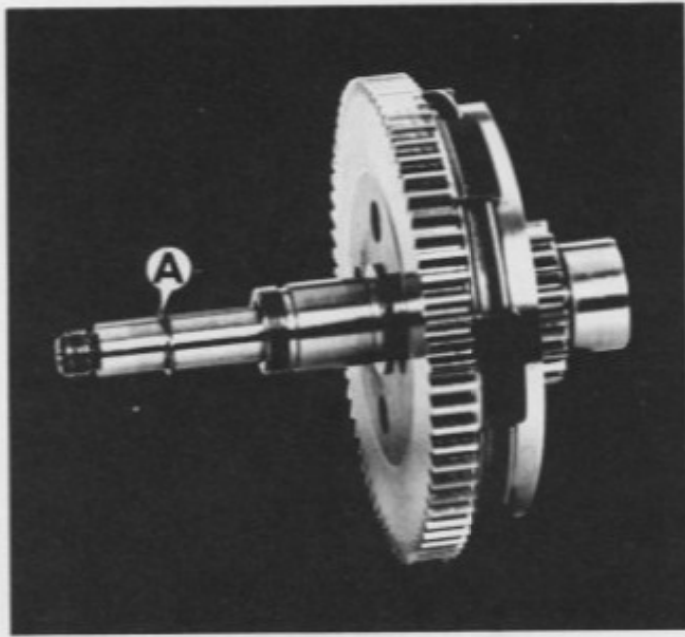

Figure 95 — Longitudinal Clutch

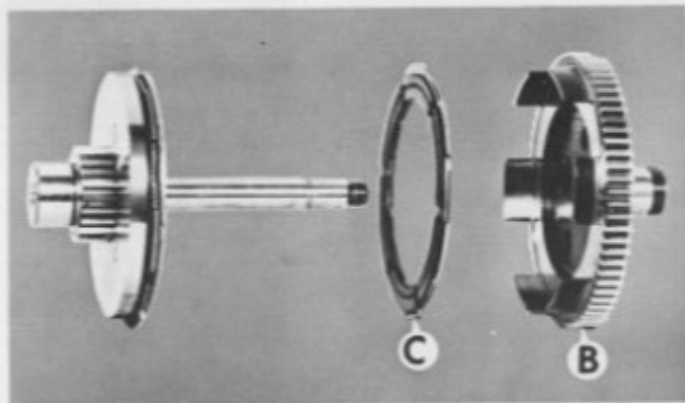

Figure 96 — Longitudinal Clutch Components

Figure 97 — Longitudinal Clutch Components

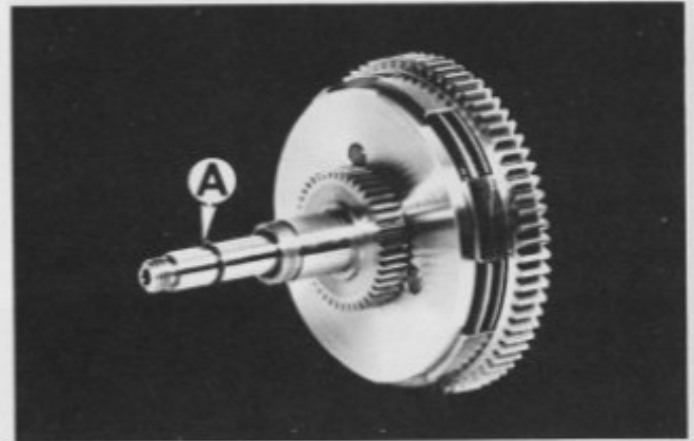

Figure 98 — Cross Feed Clutch

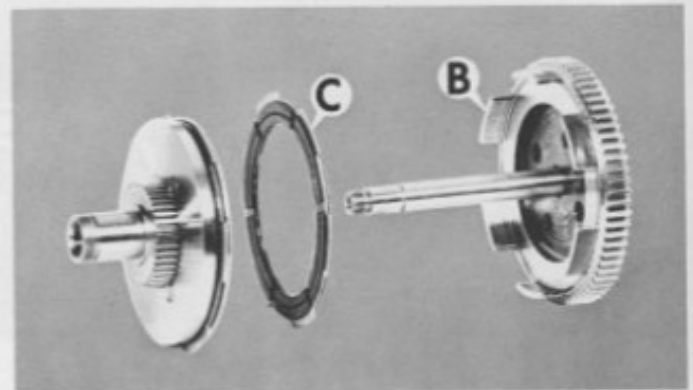

Figure 99 — Cross Feed Clutch Components

(c) Remove snap rings "D", Figure 97, clutch disc "E", clutch plate "F" and wave washer "G".

11. To disassemble cross feed clutch:

(a) Remove snap ring "A", Figure 98.

(b) Remove shaft and 70 tooth gear "B", Figure 99. Remove clutch plate "C".

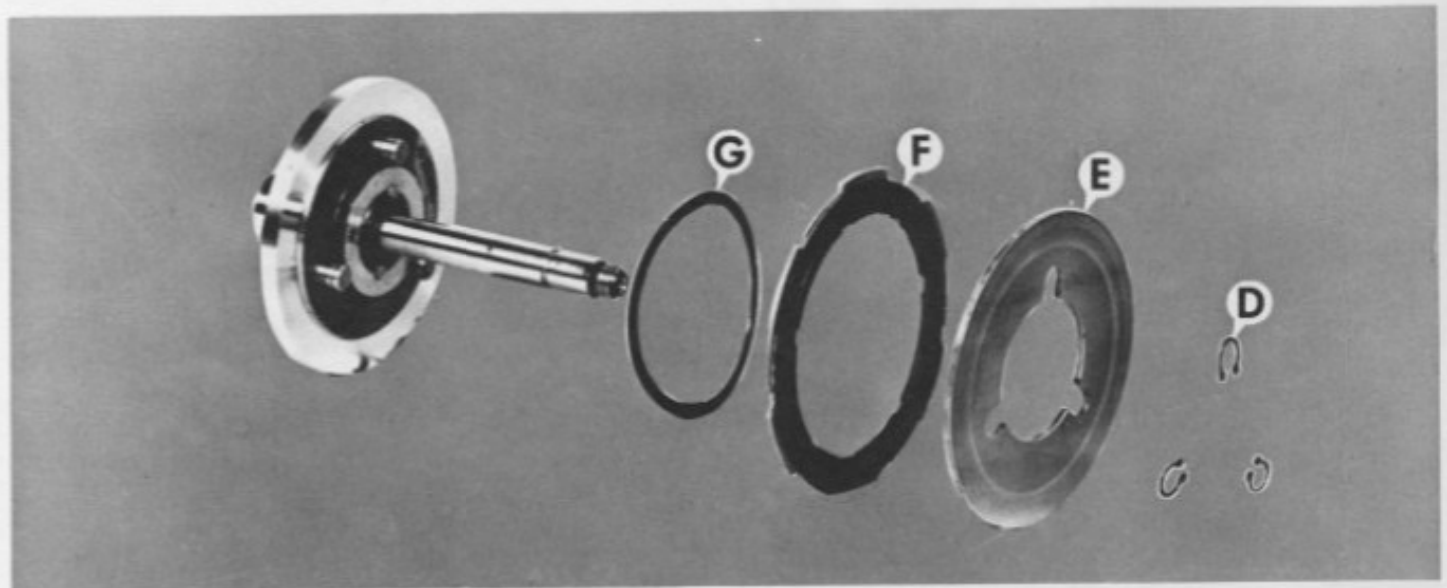

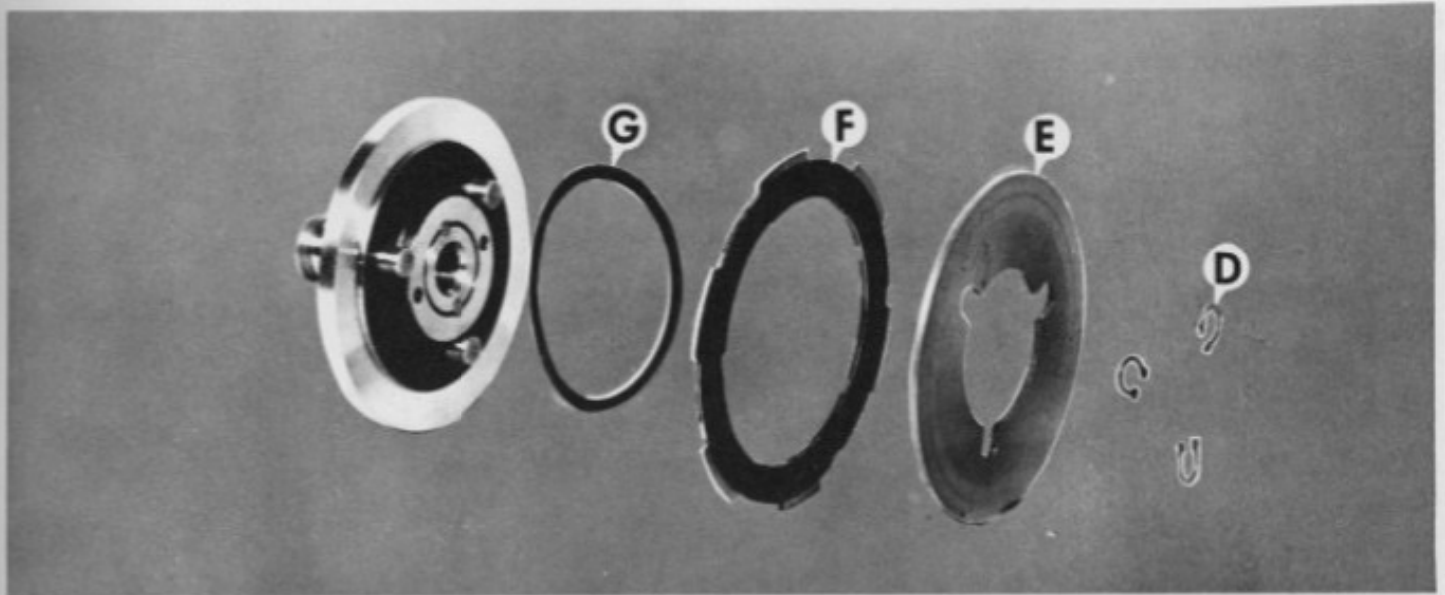

Figure 100 — Cross Feed Clutch Components

(c) Remove snap rings "D", Figure 100, clutch disc "E", clutch plate "F" and wave washer "G".

12. To disassemble clutch housings:

- (a) Remove spring "A", Figure 101, and plunger "B".
- (b) Remove cap "C", Figure 102, and nut "D".
- (c) Loosen screw "E" and remove camshaft "F".
- (d) Remove sleeve "G" and bolt "H".

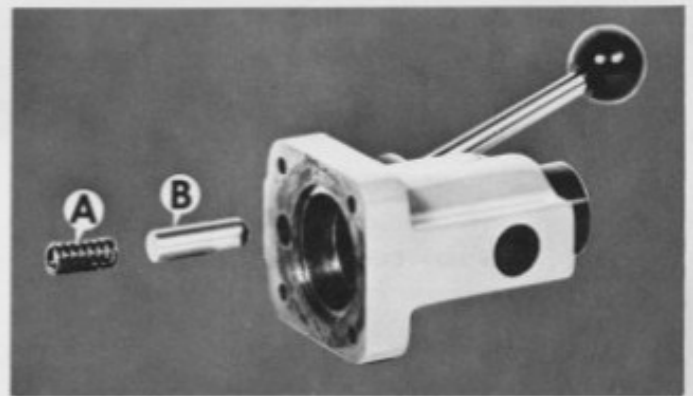
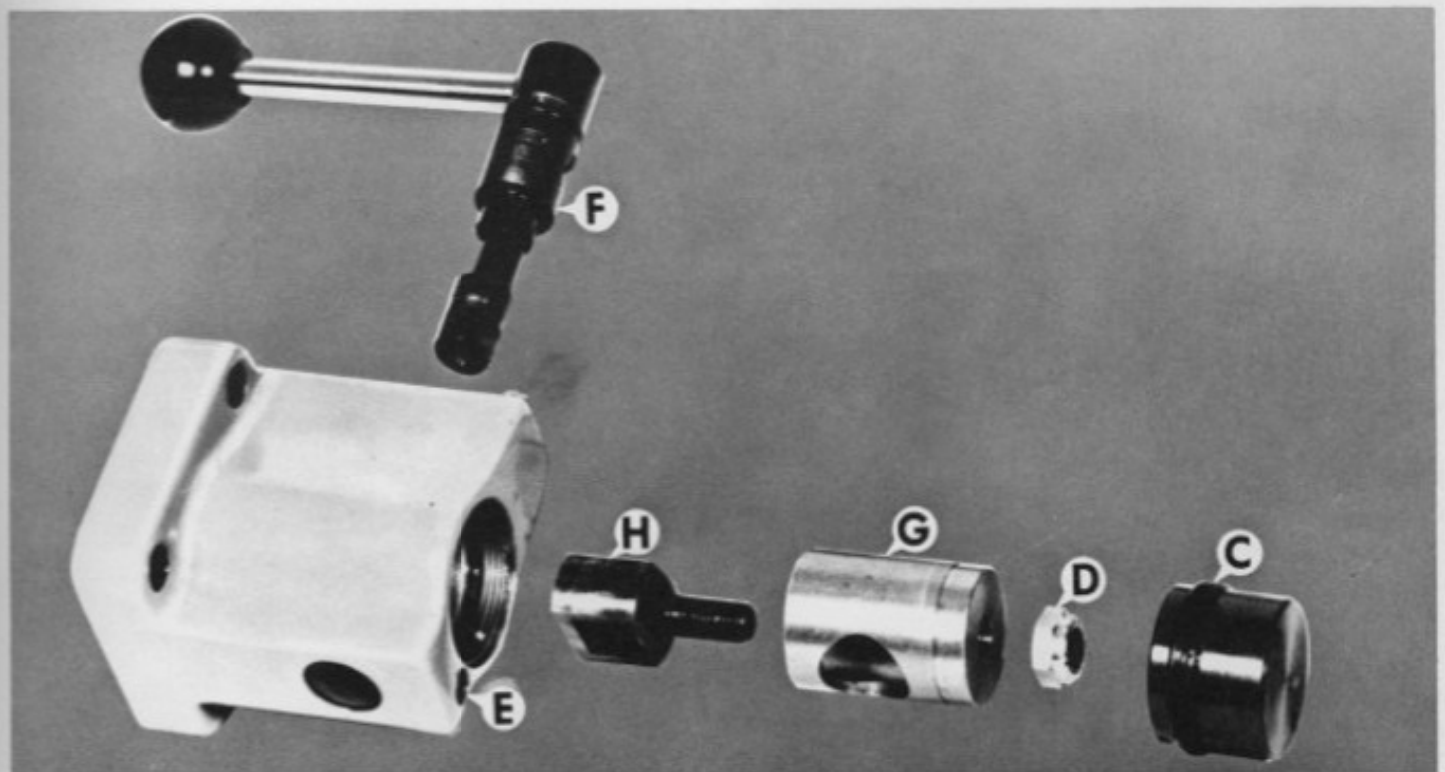

Figure 101 — Clutch Plunger and Spring

Figure 102 — Clutch Housing and Components



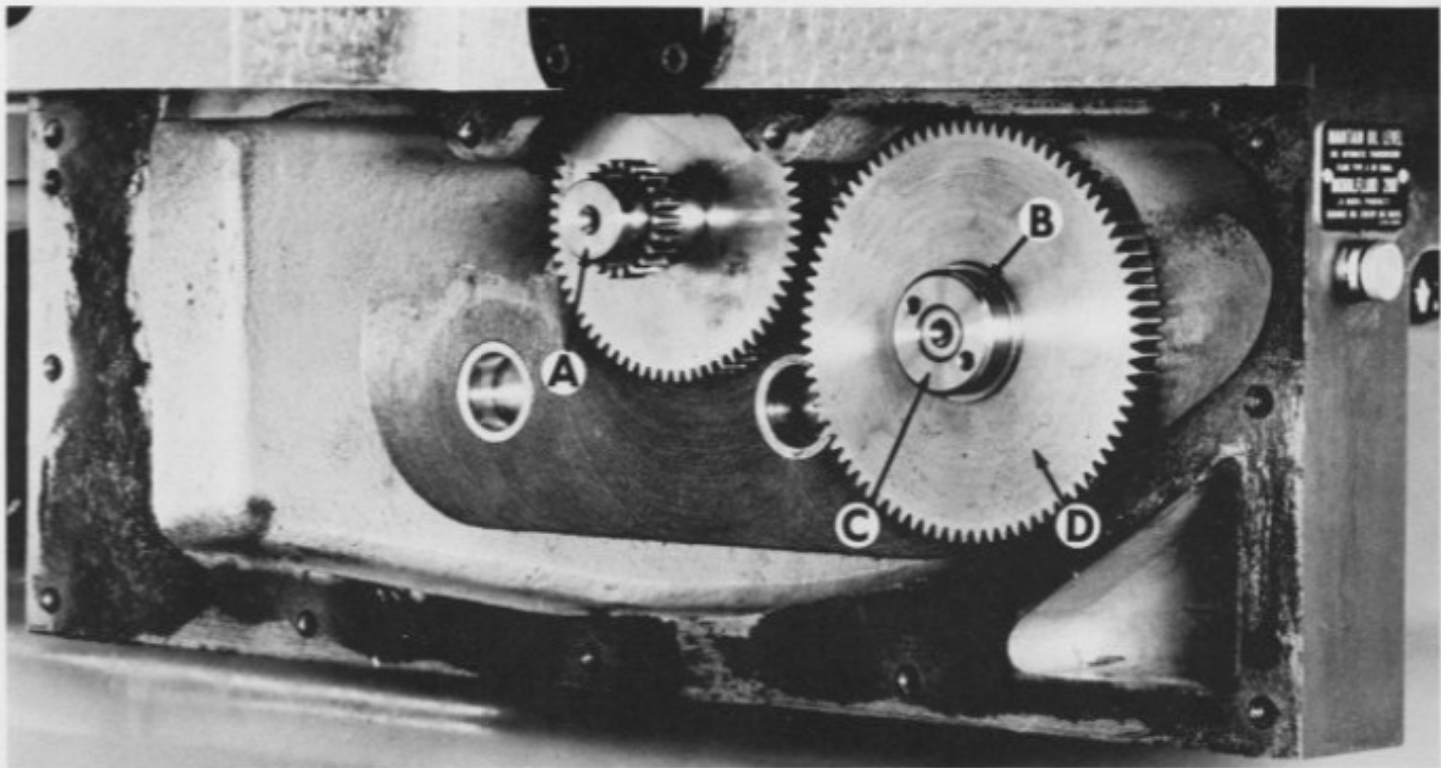

Figure 103 — Clutch Bearing Removal

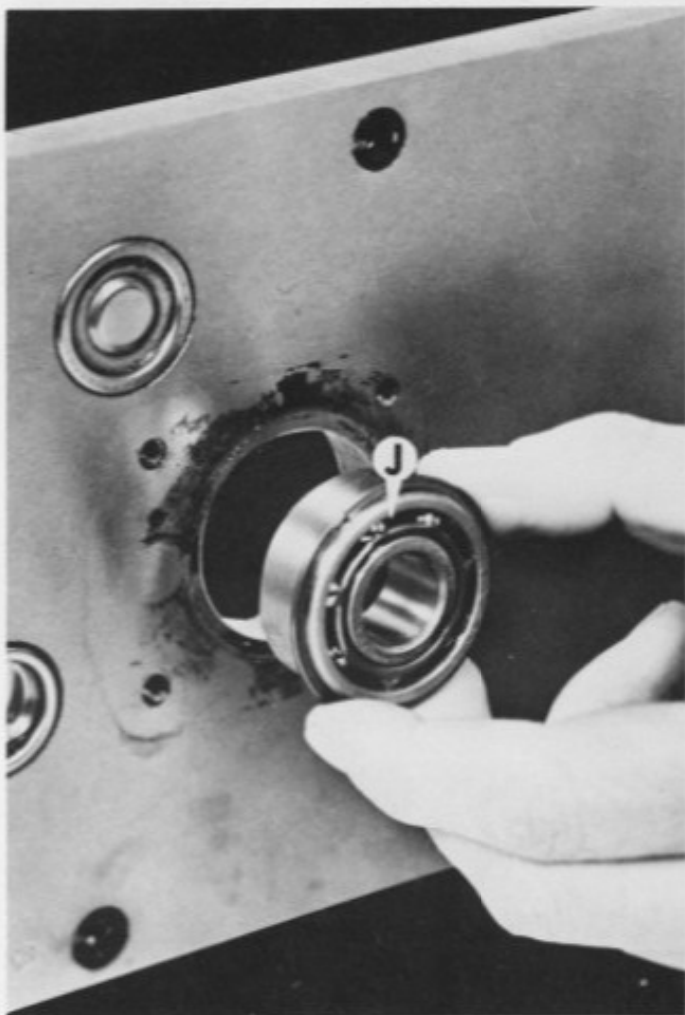
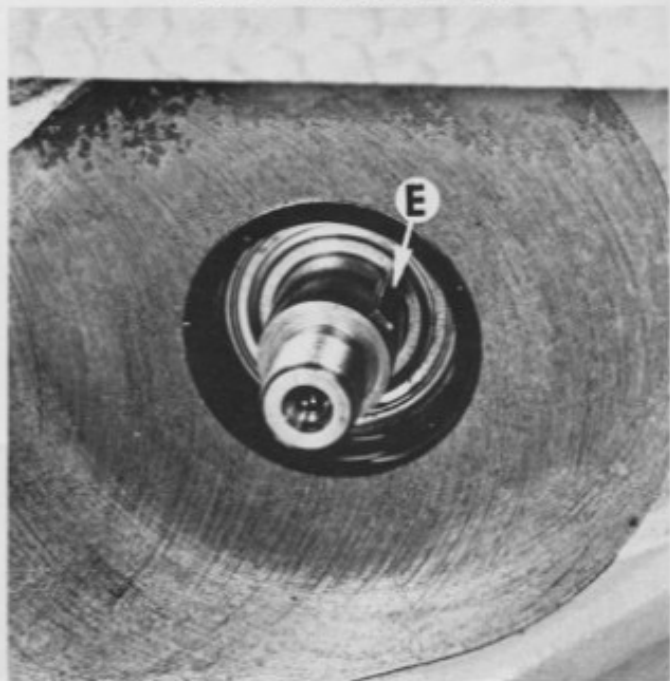

Figure 104 — Carriage Apron with Cover Removed

13. Clutch bearing "J", Figure 103, is removed from face of cover. **IT IS NOT NECESSARY TO REMOVE SNAP RING** on bearing for clutch disassembly.
14. To remove 120 tooth gear "H", Figure 92, drive out with punch at stud "J".
15. Remove intermediate gear "A", Figure 104.
16. Loosen set screw "B" and remove nut "C" with spanner wrench. Do not lose brass plug under set screw "B".
17. Remove washer and 80 tooth gear "D".

Figure 105 — Pinion Shaft and Key



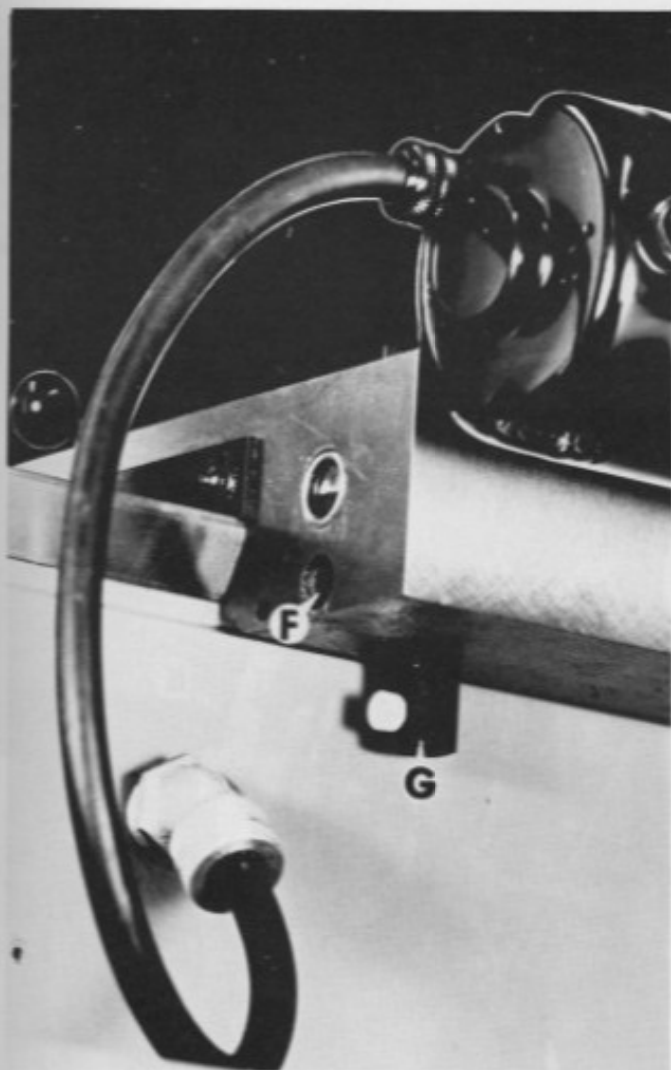

Figure 106 — Carriage Stop

Figure 107 — Rack Pinion Removal

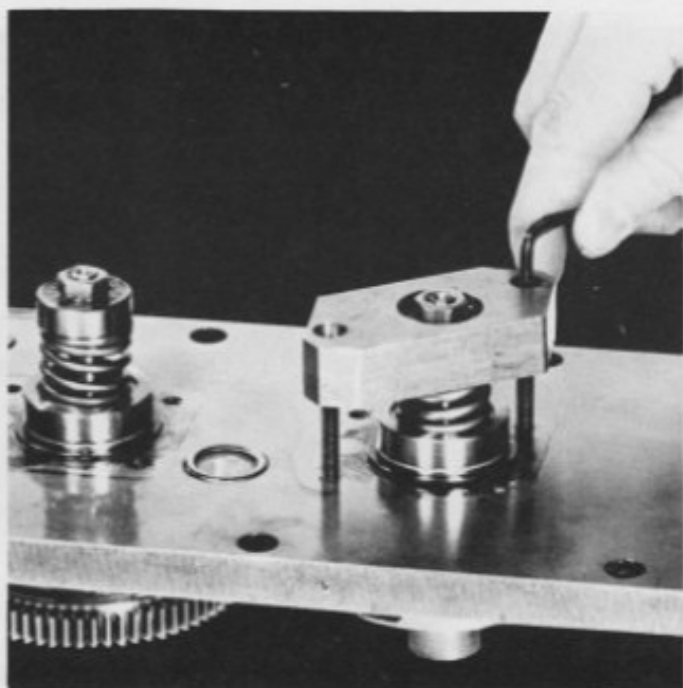

Figure 108 — Clutch Spring Replacement

18. Remove key "E", Figure 105.
19. Loosen screw "F", Figure 106, to remove carriage stop "G".
20. Remove three bolts "B", Figure 43, and set power feed control to rear of coolant pan.
21. Pull carriage past end of bed (so pinion will clear) and remove pinion, Figure 107.

CARRIAGE REASSEMBLY

1. Replace rack pinion, Figure 107.
2. **LIFT BED WIPER**, which is spring loaded, and push carriage back on bed.
3. Replace power feed control and bolts "B", Figure 43.
4. Replace carriage stop "G", Figure 106, and tighten screw "F".
5. Assemble key "E", Figure 105, and washer and 80 tooth gear "D", Figure 104.
6. Assemble nut "C", Figure 104, and tighten set screw "B".
7. Assemble intermediate gear "A", Figure 104, and 120 tooth gear "H", Figure 92.
8. Replace clutch bearings "J", Figure 103.
9. Reassemble clutches and clutch housings. (Reverse steps 10, 11 and 12 under "Carriage Disassembly.")
10. Assemble nut "G", Figure 93, spacer "F", spring seat "E", spring "D", washer "C" and bearing "B".

11. Assemble nut "A". Some method of compressing spring until nut can be threaded on flush with post is necessary. Note bracket used in Figure 108.
12. Permatex carriage cover and replace. Assemble nine screws "E", Figure 88.
13. Permatex cover "D", Figure 90. Assemble seal, cover "D" and two screws "C".
14. Permatex seal clutch housing. Pack spring "A", Figure 101, with Shell Alvania #3 grease. Replace clutch housings and eight screws "B", Figure 88.
15. Permatex handwheel housing. Assemble handwheel and four screws "A", Figure 88.
16. Fill apron with oil per Page 24.
17. Adjust clutches as shown, Figure 109. When properly adjusted clutch will release when ball lever is approximately 25° below horizontal. **CLUTCHES** are spring loaded and **CANNOT BE ADJUSTED FOR MORE PULLING POWER**. With clutch handle in notched position, tighten screw "E", Figure 102.

CROSS FEED SCREW AND DIAL REMOVAL

1. Follow steps 1, 2, 4, 5 and 6 under "Carriage Disassembly", Page 26.
2. Remove lock screw "A", Figure 110, and set screw and pin under lock screw "A". Remove handle "C".
3. Remove nut "B" and dial assembly "D".

Figure 109 — Power Feed Clutch Adjustment

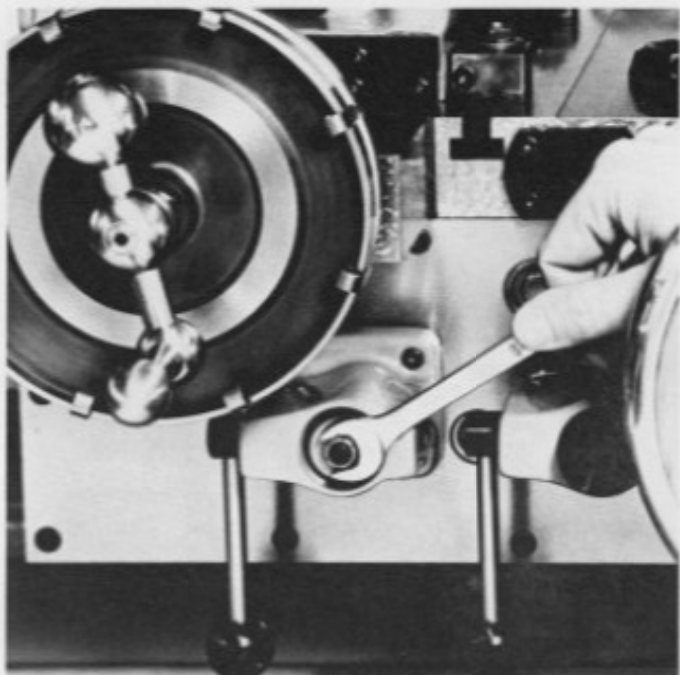

4. Remove nut "E", Figure 111.
5. Remove feed screw, Figure 112. If turret is on machine it may be necessary to mount handle "C" to remove from feed screw nut.
6. Remove two screws "F", Figure 111, and remove bearing housing and zero ring.
7. Bearing "G" and two seals "H" and "J", Figure 113, are pressed into carriage bore.

Figure 110 — Cross Feed Screw Dial

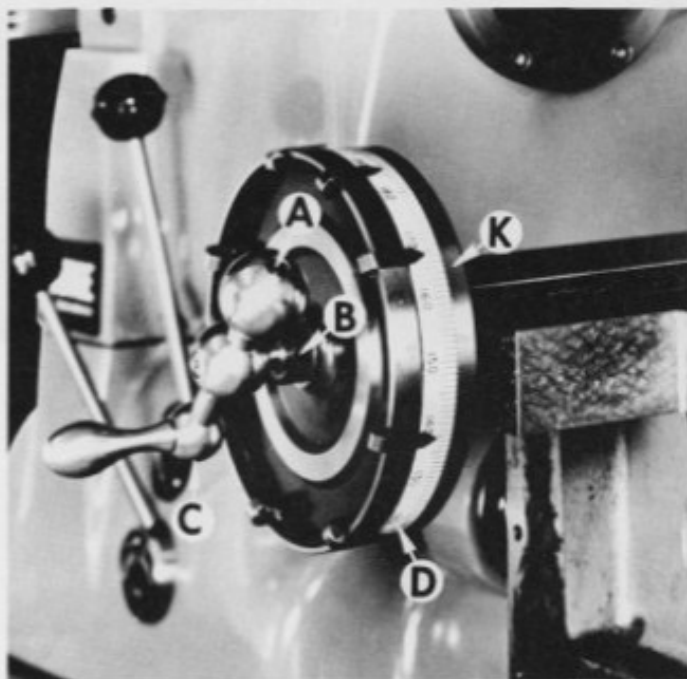
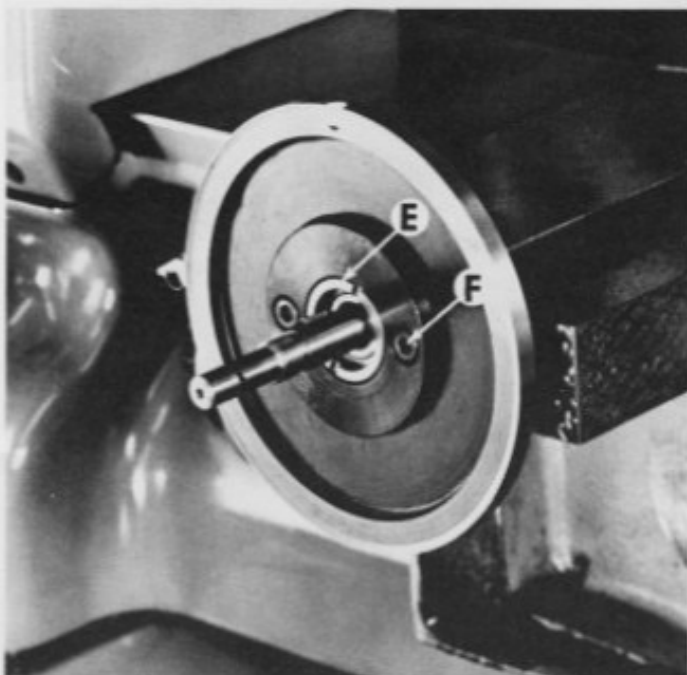

Figure 111 — Feed Screw Bearing Housing



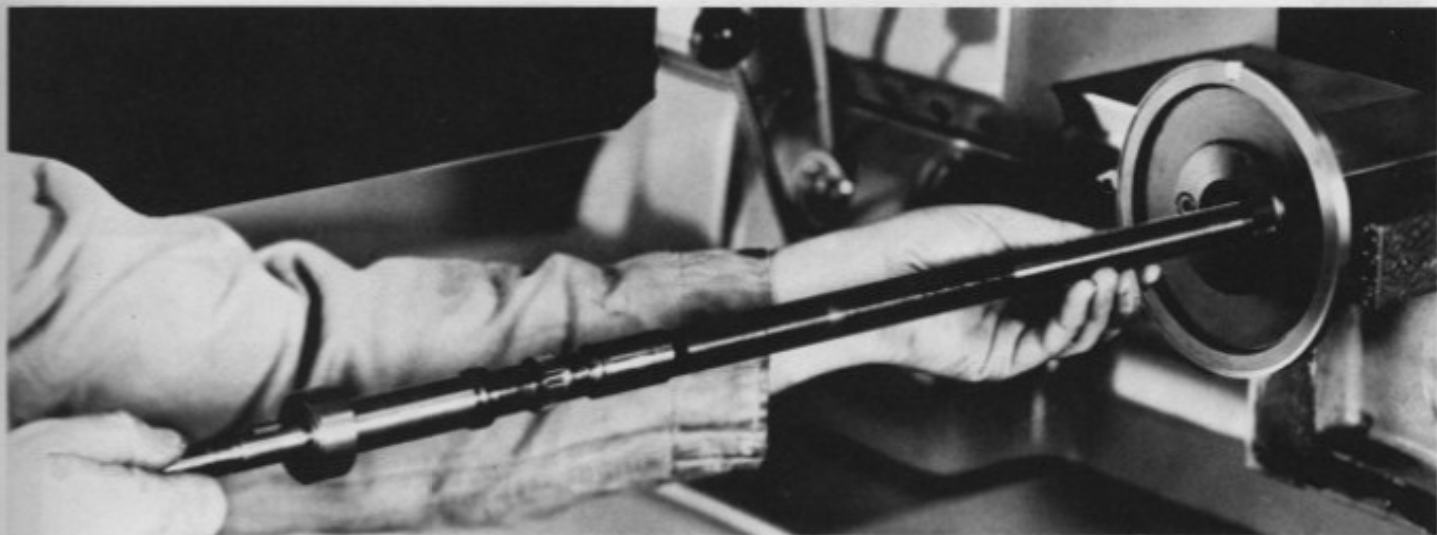
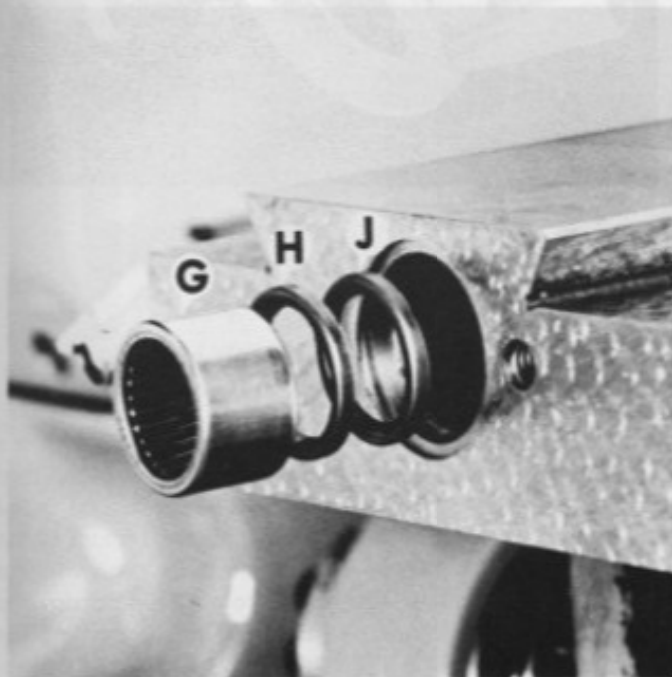

Figure 112—Cross Feed Screw Removal

CROSS FEED SCREW AND DIAL REPLACEMENT

1. Press seal "J", Figure 113, into carriage bore $6\frac{1}{4}$ " from face of carriage. Press seal "H" and bearing "G" to depths of 6" and $4\frac{3}{4}$ " respectively.
2. Replace bearing housing and zero ring and two screws "F", Figure 111.
3. Replace feed screw, Figure 112.
4. Replace nut "E", Figure 111, dial assembly "D" and nut "B", Figure 110.
5. Replace handle "C", pin, set screw and lock screw "A".
6. Follow steps 12, 13, 15, 16 under "Carriage Reassembly", Page 31.

Figure 113—Bearing and Seals for Feed Screw



7. Lubricate cross slide feed screw nut per instructions, Page 18.
8. The gap between dial "D" and zero ring "K", Figure 110, should be set at .002" to .004". To change gap loosen set screw in hub of zero ring "K".

CARRIAGE RACK REMOVAL

1. Remove carriage drum stop.
2. Move carriage to extremes to remove five screws "A", Figure 114.
3. Remove rack "C" by prying alternately at both ends with small sharp screwdriver. It may be necessary to rap rack back in place to position dowels "B" midway in rack for removal.

Figure 114—Carriage Gear Rack

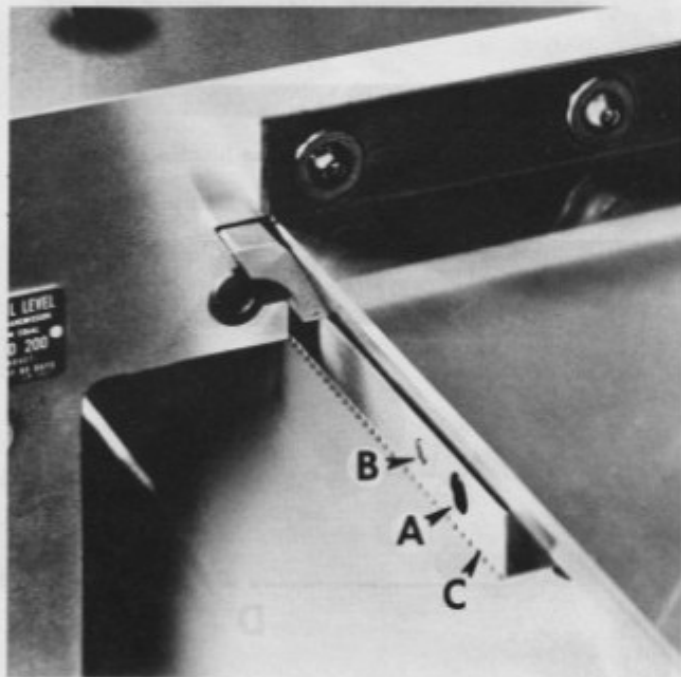

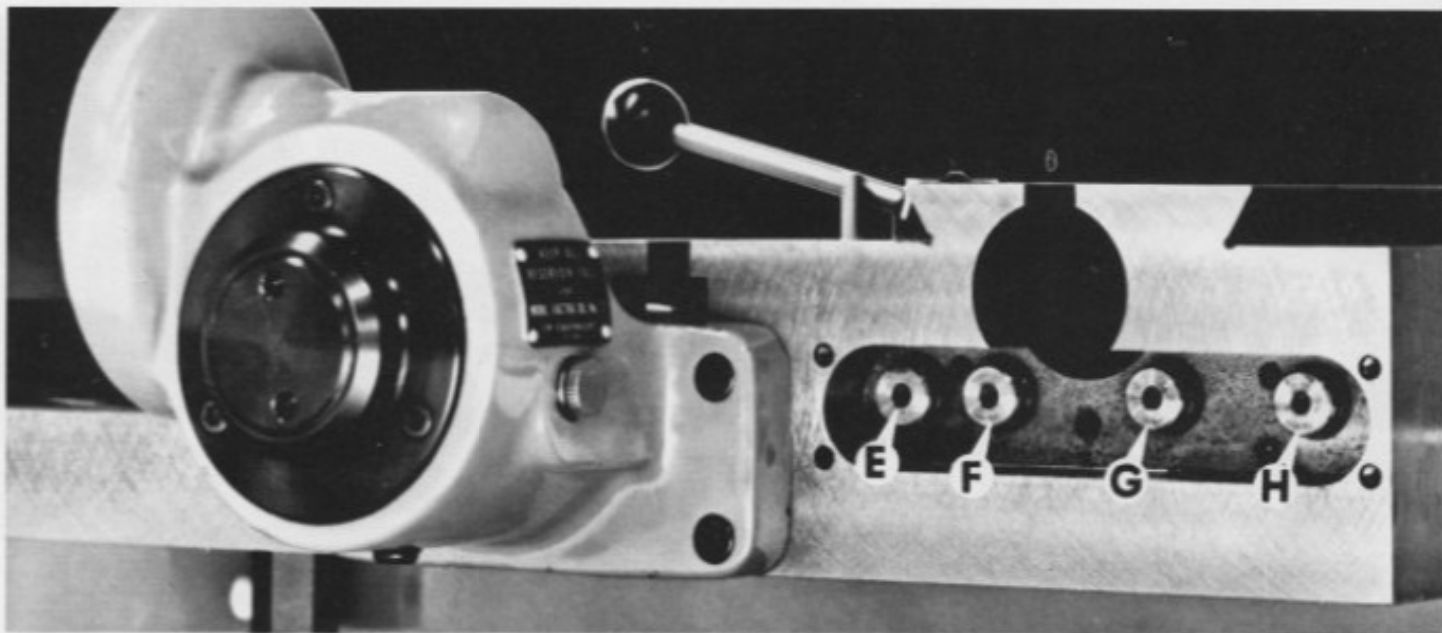

Figure 117 — Carriage Lubricator Assemblies

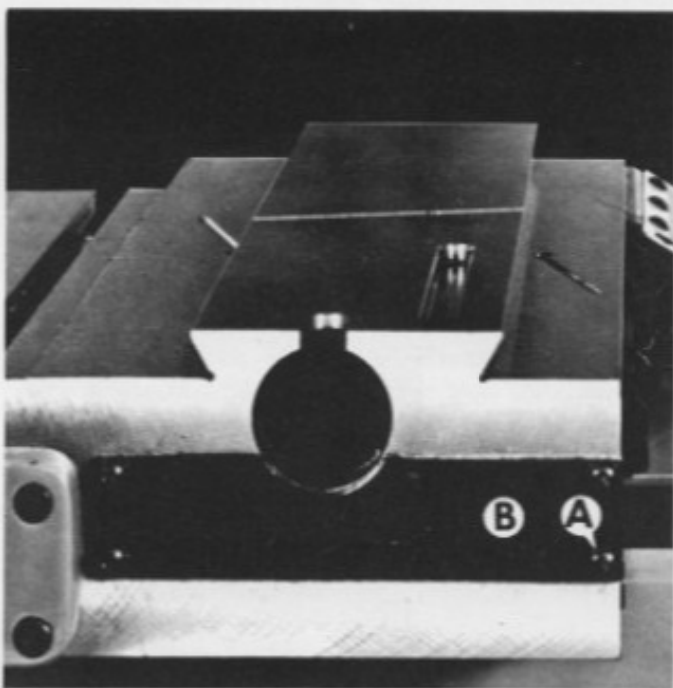

Figure 115 — Cover for Lubricator Junction Block

Figure 116 — Carriage Lubricator Junction Block

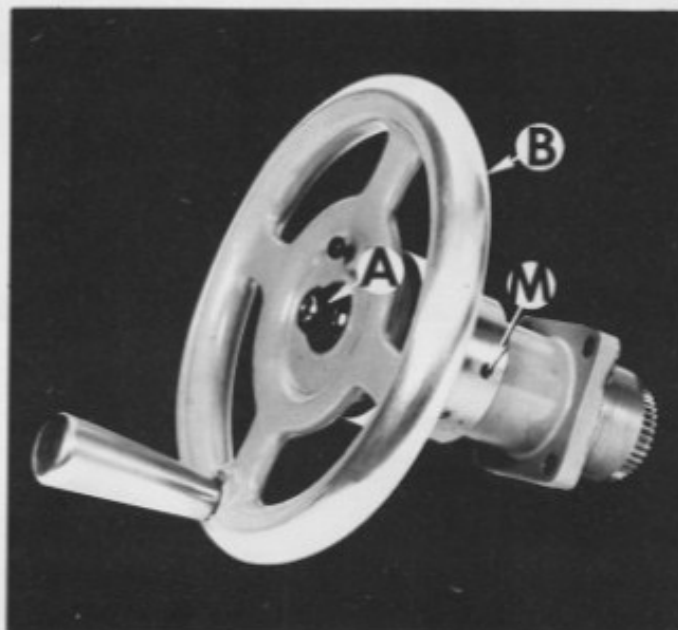
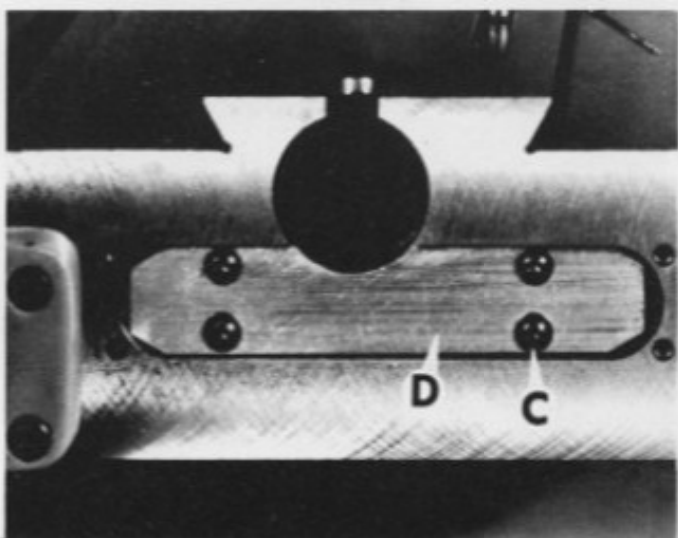

Figure 118 — Carriage Handwheel

CARRIAGE LUBRICATION SYSTEM

Lubricating oil for the carriage is channeled from the lubricator "B", Figure 86, to a junction block at the rear of the carriage. From the junction block the oil is fed in four tubes to channels in the top and bottom of the carriage. Three of these channels can be seen with the cross slide removed. On the bottom of the carriage is a large almost "X" shaped channel for lubricating the bed ways.



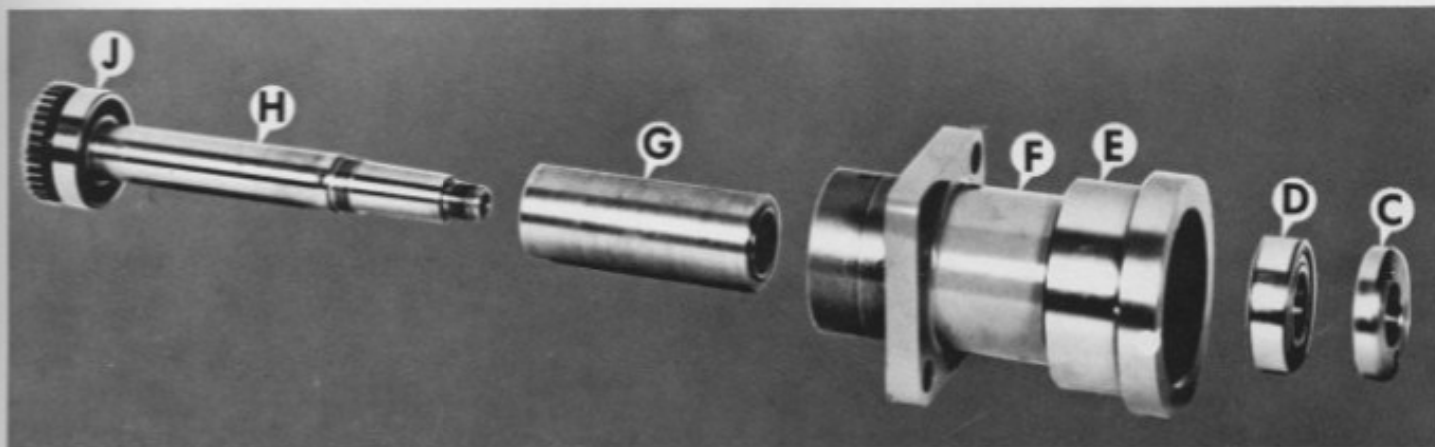

Figure 120 — Carriage Handwheel Components

1. TO GAIN ACCESS TO THE JUNCTION BLOCK, remove four screws "A", Figure 115, and cover "B".
2. Remove four screws "C", Figure 116, and junction block "D".
3. Remove lubricator assemblies "E", "F", "G" and "H", Figure 117. Lubricator assemblies "E", "G" and "H" are for channels in the top of carriage and "F" is for the channel in the carriage bottom. **DO NOT INTERCHANGE LUBRICATOR ASSEMBLIES.**

CARRIAGE HANDWHEEL DISASSEMBLY

1. Remove four screws "A", Figure 88, and remove handwheel assembly, Figure 89.
2. Remove nut "A", Figure 118, and washer.
3. Remove handwheel "B".

Figure 119 — Carriage Handwheel Housing

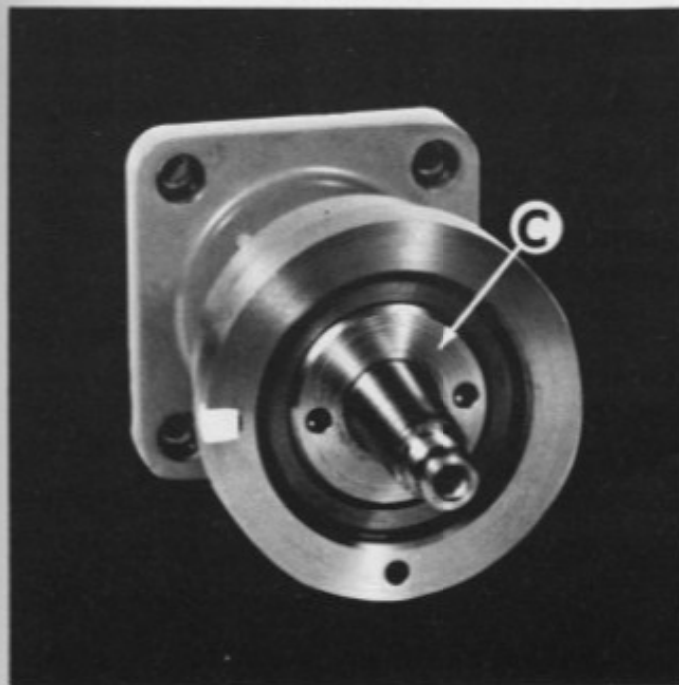

4. Remove nut "C", Figure 119, with spanner wrench.
5. Remove bearing "D", Figure 120, spacer "G" and shaft "H" from housing "F". Bearing "J" is pressed on shaft "H".
6. Remove snap ring "K", Figure 121, to remove dial "L" from handwheel.
7. Reassemble. Permatex seal handwheel housing and replace handwheel assembly. The gap between dial "L", Figure 121, and zero ring "E", Figure 120, should be set at .002" to .004". To change gap loosen set screw "M", Figure 118.

Figure 121 — Carriage Handwheel Dial



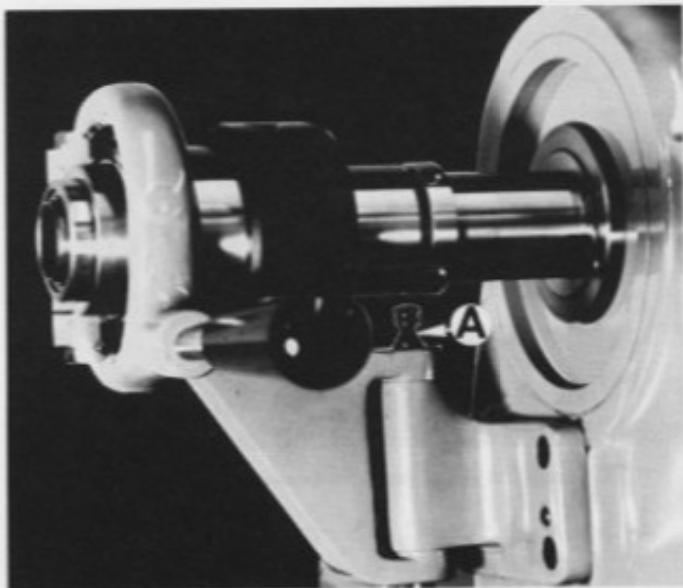

Figure 122 — Collet Closer

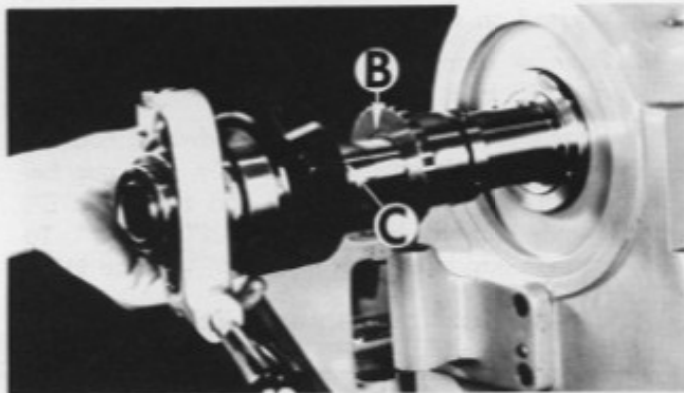

Figure 123 — Collet Closer Removal

COLLET CLOSER REMOVAL

1. Remove link pin "A", Figure 122, only. This pin is easily removed by pulling up and out with fingers.
2. Remove collet closer as shown, Figure 123. To remove adjusting nut "B", pull straight off end of spindle. **DO NOT TURN ADJUSTING NUT—IT IS NOT THREADED TO SPINDLE.** The collet closer should be removed weekly and between set ups for cleaning to prevent loading of chips between collet closer tube and inside of spindle at rear end and collet threads.

COLLET CLOSER REPLACEMENT

1. Clean the inside of the headstock spindle before applying collet closer. Also, clean outside diameter at the rear of spindle where adjusting nut locates. Clean collet closer tube inside and out.

2. Apply a film of light oil on rear of headstock spindle and replace adjusting nut "B", Figure 123. **DO NOT FORCE ADJUSTING NUT ON SPINDLE. IF ADJUSTING NUT GOES ON TIGHT, REMOVE AND EXAMINE FOR BURRS OR SCRATCHES.** Apply a film of light oil on bearing section "C", Figure 123, of collet closer tube, replace closer and insert link pin "A", Figure 122.

SPINDLE LOCK PIN

The electrical interlock between lock pin "A", Figure 124, and the main drive motor is controlled by limit switch "B", Figure 125, located under Hardinge name plate "C", Figure 124. The limit switch "B" is actuated by a plunger moved by lock pin "A".

SPINDLE LOCK PIN LIMIT SWITCH REPLACEMENT

1. Turn disconnect switch to "Off" position.
2. Remove cover "C", Figure 124.
3. Remove screws "D", Figure 125, and limit switch "B" and disconnect wires.
4. When replacing limit switch, connect wires to normally closed and common terminals.
5. Clearance in the mounting holes will allow limit switch "B" to be located in proper position for tripping.

HEADSTOCK SPINDLE BEARING LUBRICATION

The headstock spindle is mounted on precision preloaded ball bearings. The preloading and resulting load-carrying capacity is engineered to take radial thrust or end thrust or a combination of both.

THE PRECISION PRELOADED BALL BEARINGS ARE GREASE PACKED FOR LIFE and require no further lubrication. The entire bearing assembly is housed as a unit and is properly sealed to exclude dirt and foreign matter. The spindle bearing seals are designed to operate at high speed without wear or friction.

HEADSTOCK REMOVAL

For repairs to headstock spindle or bearings, return headstock to Hardinge. Unit should be properly greased to prevent rust.

1. Follow steps 1 through 6 and 8 through 11 under "To Replace Drive Belts", Page 3.
2. Remove threading attachment if machine so equipped. See maintenance manual for automatic threading unit on HC chucking machine.
3. Loosen set screw "E", Figure 124, and remove control head.
4. Remove cover "C", Figure 124, and disconnect wires from limit switch "B", Figure 125.
5. Remove conduit nut "F", Figure 124, and pull wires out of headstock.
6. Loosen five screws "G", Figure 124.
7. Using hoist and sling, Figure 126, slide headstock off and up. **CAUTION:** If sling is placed around headstock spindle, lift head with smooth motion to prevent damage to super-precision spindle. Do not misplace seal under headstock.

TO REPLACE HEADSTOCK

1. Replace headstock and tighten screws "G", Figure 124, alternately and evenly.
2. Assemble other components,

Figure 124

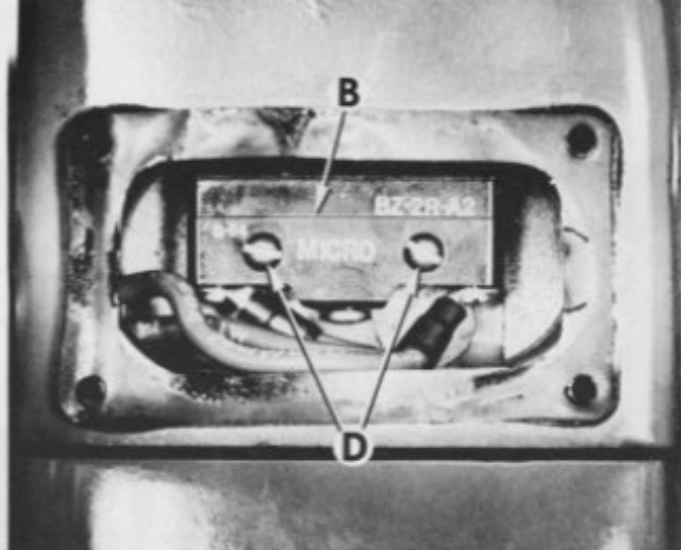

Figure 125 — Spindle Limit Switch

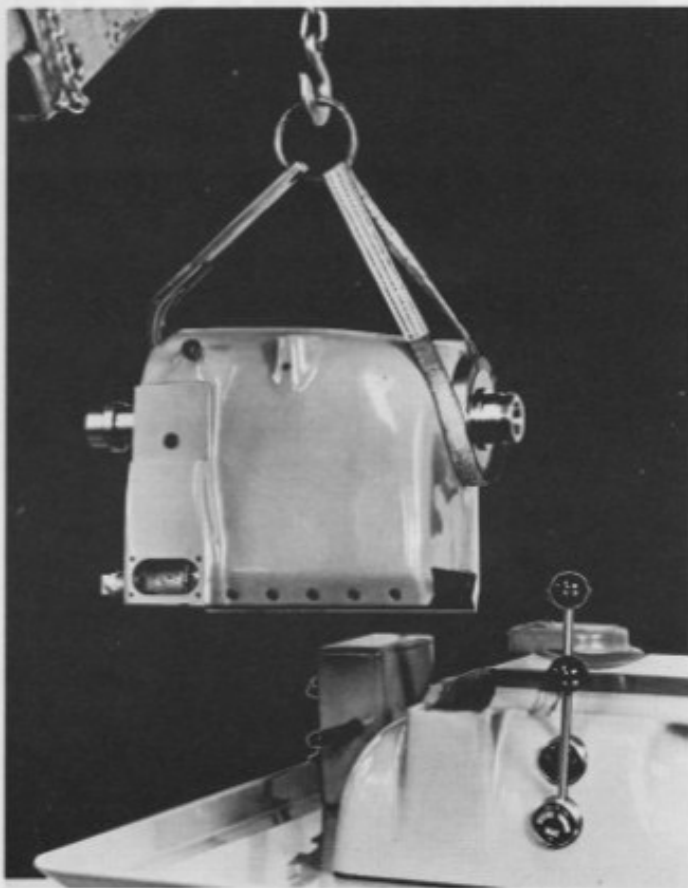

Figure 126 — Headstock Removal

COOLANT FACILITIES

OIL BASE CUTTING FLUIDS ARE RECOMMENDED FOR MAXIMUM MACHINE LIFE.

Clean sump regularly, depending upon type of material being run.

To clean sump, remove four screws and screen cover for sump. Rinse out and drain sump by removing pipe plug at rear of machine. Coolant capacity is three gallons.

The coolant pump motor bearings are greased packed for life and require no further attention.

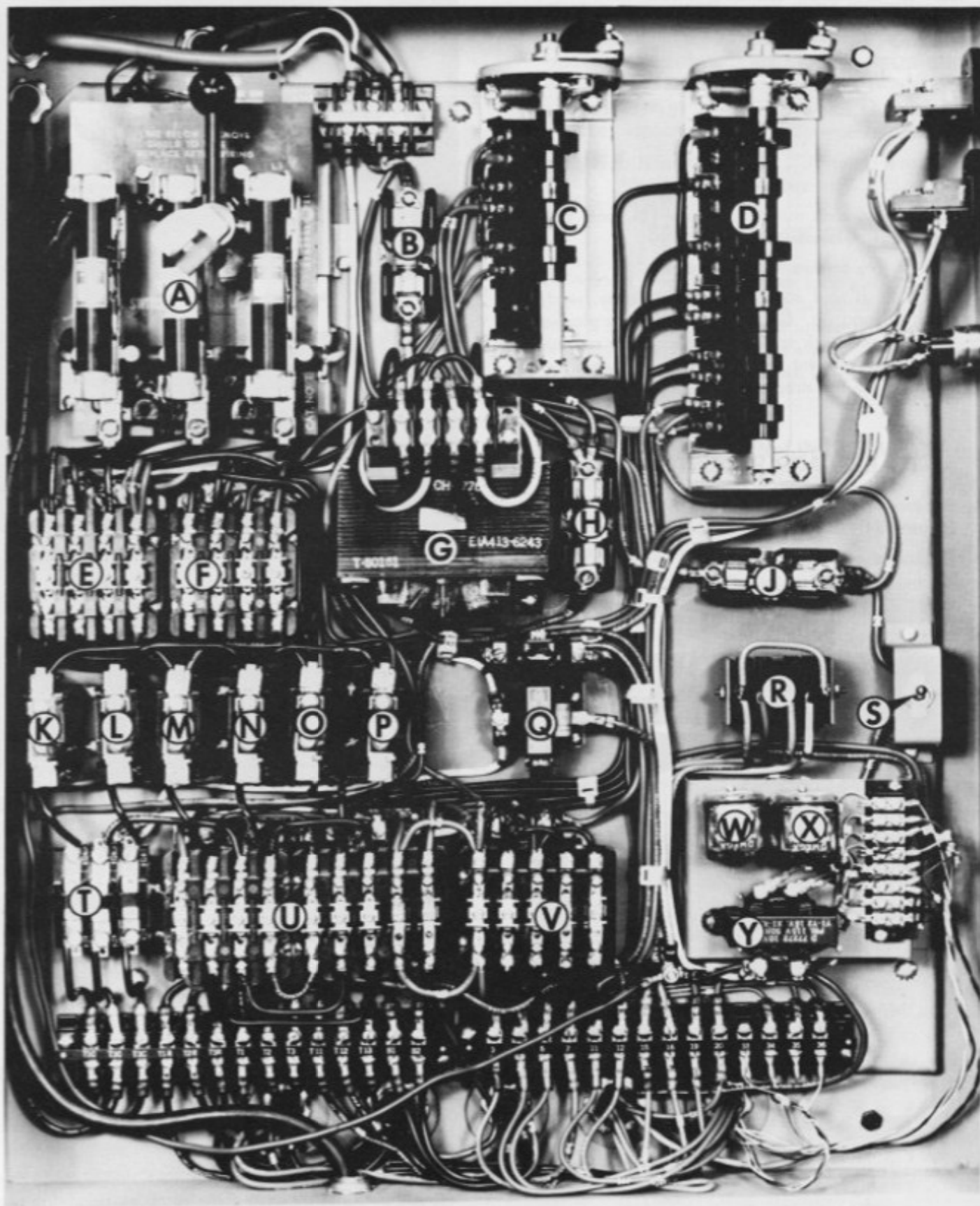

Figure 127 — Main Switch Case

ELECTRIC CONTROL FUNCTIONS

(Figure 127 and 128)

A—Disconnect switch and main line fuses (220 volt—FRS10) (440 volt—FRS5)

B—Fuse for thread chasing attachment (FRN 1-¼)

C—Speed selector drum switch.

D—Forward, reverse drum switch.

E—Starting contactor (energizes complete circuit).

F—Contactor for spindle interlock relay.

G—Control voltage transformer (115 volt output with 10 volt tap for threading attachment).

H—Control circuit fuse (FRN 2-½).

J—Power feed fuse (FRN 1-8/10).

K & L—Overload relays for coolant motor (push to reset).

M & N—Overload relays for speed change motor (push to reset).

O & P—Overload relays for spindle motor (push to reset).

Q—Spindle brake relay (when energized brake is released).

R—Rectifiers providing DC voltage for speed change brake.

S—Variable speed drive safety switch—Switch should not be turned to "On" position until spindle is rotating counterclockwise when viewed from turret end of machine.

T—Coolant pump contactor.

U—Speed change contactor (raise and lower).

V—High, low contactor for spindle motor.

W—Spindle "Raise Speed" Relay
X—Spindle "Lower Speed" Relay

If drive operates in one direction only, interchange "W" and "X" to check for faulty relay.

Y—Variable speed transformer (Speed change power supply).

Figure 128

1. Smoothing capacitors for DC voltage for rheostats.
2. Rectifiers providing DC voltage for rheostats.

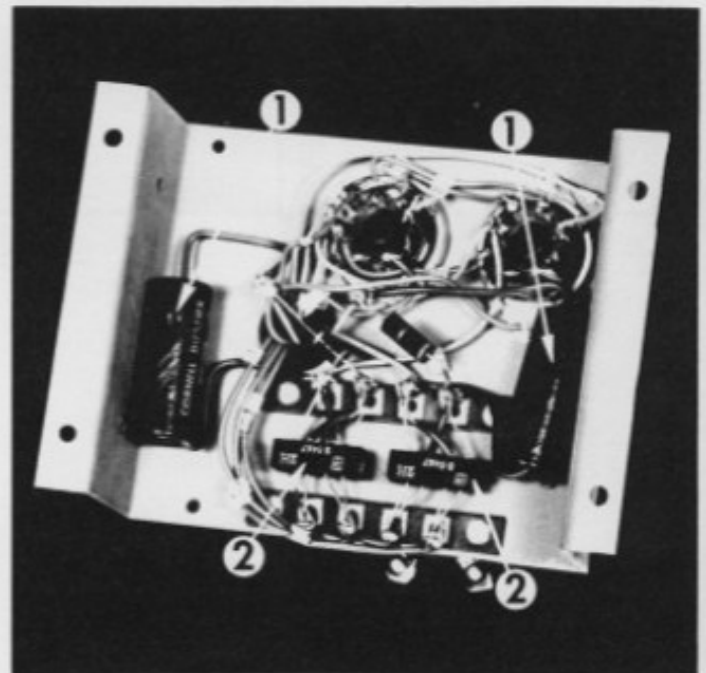

Figure 128 — Power Supply and Relay Assembly

LUBRICANTS AND SEALER

(Use Recommended Product or Equivalent)

Permatex (3D Sealer)
Spindle Oil (Velocite No. 6)
Absorbed Oil #L-4 ½ (Superseded by Cosmolube No. 2)
Andok "B" Grease
Molyube (Anti-Seize)
Vactra Oil No. 2
Automatic Transmission Fluid - Mobilfluid 350
Alvania #3 Grease

Permatex Company, Inc.
Mobil Oil Corporation
Houghton, E. F. and Company
Humble Oil and Refining Company
Bel Ray Company, Inc.
Mobil Oil Corporation
Mobil Oil Corporation
Shell Oil Company

CARRIAGE REMOVAL

1. Follow steps 1 through 5 under "Cross Slide Removal", Page 18.
2. Loosen screw "F", Figure 106, to remove carriage stop "G".
3. Remove three bolts "B", Figure 43, and set power feed control to rear of coolant pan.
4. Follow steps 6 and 7 under "Power Feed Drive Disassembly", Page 15.
5. Insert 1/4" hex pin wrench in screw "A", Figure 84, and loosen one turn. Insert wrench on through into screw "B", Figure 59 and loosen one turn.
6. Using longitudinal handwheel, feed carriage to machine right until travel stops. Pull carriage off end of bed. **Hold gib in place** to prevent it from dropping out.

CARRIAGE REPLACEMENT

1. With gib in place, start carriage on bed. **Lift Bed wiper** and move slowly into position until gear rack and pinion mesh properly. Using longitudinal handwheel, feed carriage toward headstock end of bed.
2. Readjust gib with screws "A" and "B", Figure 59. See "Carriage Gib Adjustment", Page 24.
3. Replace pipe plug "E", Figure 46, power feed drive and three screws "F". Fill reservoir with Mobil Vactra Oil #2.
4. Replace power feed control and three bolts "B", Figure 43.
5. Replace carriage stop "G", Figure 106, and tighten screw "F".
6. Follow steps 1 through 3 under "Cross Slide Replacement", Page 18.

— NOTES —



HARDINGE BROTHERS, INC., ELMIRA, N.Y. 14902
"PERFORMANCE HAS ESTABLISHED LEADERSHIP FOR HARDINGE"™