

**Ersatzteilliste EMCO COMPACT 8**  
**Service parts for EMCO COMPACT 8**  
**Pièces de service pour EMCO COMPACT 8**

Ausgabe 94-11  
 Edition 94-11  
 Edition 94-11

**Inhaltsverzeichnis**

**Table of contents**

**Table des matières**

Seite Page Page	Benennung	Description	Designation
2	Grundausrüstung	Tools	Equipement de base
3	Drehmaschinenbett	Lathe bed	Banc
4	G. Spindelstock	Headstock	Poupée fixe
5	Futterschutz	Chuck guard	Protection de mandrin
7	Antrieb	Drive	Entraînement
9	Riemenspanner	Tensioning roller	Rouleau tendeur
11	E-Ausrüstung	Electrical equipment	Equipement électrique
13	Räderschere	Quadrant	Lyre
15	G. Rädersatz	Set of change gears	Jeu d'engrenages assembles
15	G. Schloßplatte	Apron	Tablier assemble
17	Längs- und Querschlitzen	Saddle and Cross Slide	Trainard et chariot transversal
19	G. Obersupport	Compound	Chariot supérieur
21	G. Reitstock	Tailstock compl.	Poupée mobile assemblée
22	G. Laufhülse	Follower rest	Lunette à suivre
23	G. Stehhülse	Steady rest	Lunette fixe
25	Supportschleifmaschine	Toolpost grinder	Rectifieuse adaptable
27	G. Maschinenständer	Machine stand	Socle-armoire
28	G. Rollkörner	Revolving center	Pointe tournante
28	G. Spannzangenhalter	Collet attachment	Ens. porte-pince



EMCO MAIER Gesellschaft m.b.H. – P.O. Box 131 – A-5400 Hallein/Austria – Tel. (06245) 891 – Fax (06245) 86965

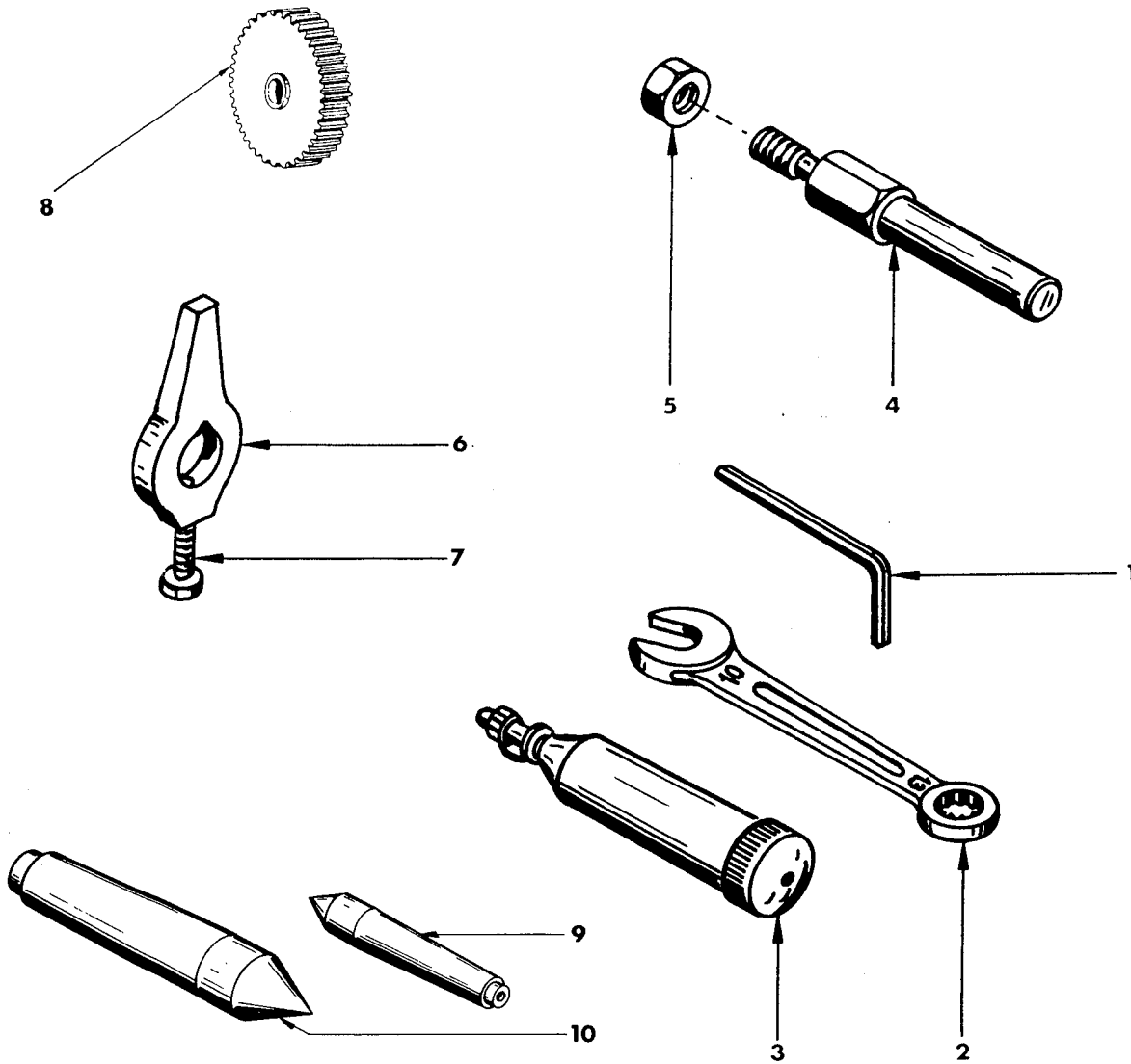

				Grundausrüstung	Tools	Equipement de base
Pos	Ref.No.	DIN		BENENNUNG	DESCRIPTION	DESIGNATION
1	ZWZ 11 0500			Sechskantstiftschlüssel	Hexagonal key	Clé coudée pour 6 pans creux
2	B2A 000 470			Ring - Maulschlüssel	Key wrench	Clé combinée plate et à oeil
3	ZWZ 99 0012			Kleinfettresse	Grease gun	Petite pompe à graisse
4	B1A 140 000 B1A 140 010			G. Mitnehmer Mitnehmerbolzen	Holding bolt Holding bolt	Ensemble pousse-toc Pousse-toc
5	ZMU 34 0800 B2A 130 000	M8 DIN 934		Sechskantmutter G. Drehherz	Nut Lathe dog	Ecrou hexagonal Toc de tour complet
6	B2A 130 010			Drehherz	Lathe dog	Toc de tour seul
7	ZSR 33 0840	M8x40 DIN 933		Sechskantschraube	Hexagon screw	Vis tête hexagonale
8	B2Z 200 070			Wechselrad z = 60	Change gear	Engrenage
9	B2A 000 420			Körnerspitze MK2	Lathe center MT2	Contre-pointe CM2
10	B2A 000 460			Körnerspitze MK3	Lathe center MT3	Contre-pointe CM3

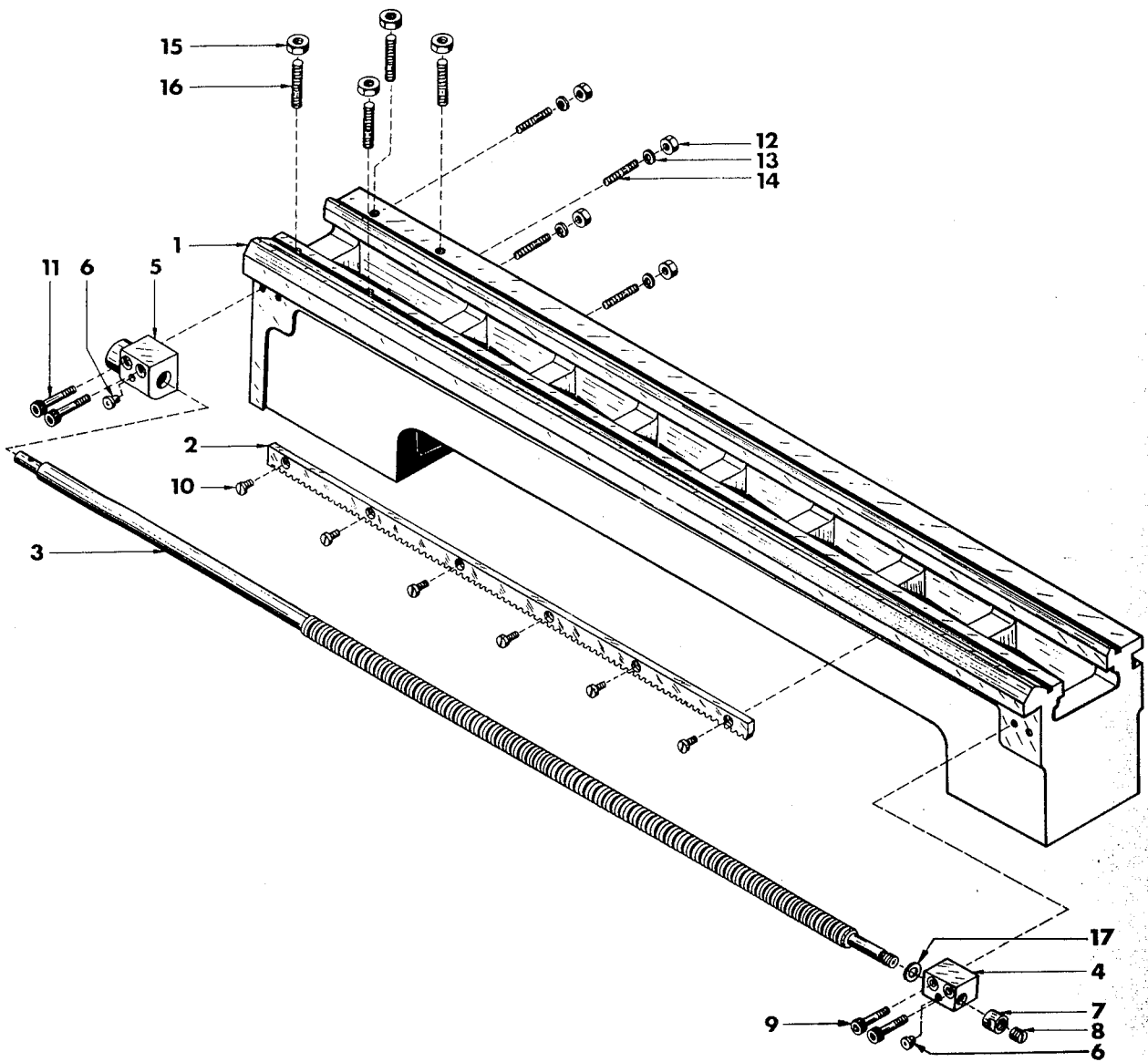

Pos	Ref. No.	DIN	Drehmaschinenbett	Lathe bed	Banc
			BENENNUNG	DESCRIPTION	DESIGNATION
1	B1A 000 030		Bett	Bed	Banc nu
2	B2A 000 020		Zahnstange	Rack	Crémaillère
3	B1A 000 070		Leitspindel metr.	Lead screw metr.	Vis-mère metr.
	B1B 000 070		Leitspindel USA	Lead screw USA	Vis-mère USA
4	B1A 000 221		Spindelträger	Bearing block	Paliersupport de vismère (droite)
5	B2A 000 030		Leitspindelträger	Bearing block	Palier-support de vis-mère (gauche)
6	ZNP 01 1000		Schmiernippel	Grease fitting	Graisseur
7	B2A 000 100		Mutter	Nut	Écrou à 2 pans
8	ZST 51 0806	M8x6 DIN 551	Gewindestift	Set screw	Contre-vis
9	ZSR 12 0630	M6x30 DIN 912	Innensechskantschraube	Allen head screw	Vis tête cylindrique
10	ZSR 84 0410	M4x10 DIN 84	Zylinderschraube	Flat head screw	Vis tête cylindrique
11	ZSR 12 0630	M6x30 DIN 912	Innensechskantschraube	Allen head screw	Vis 6 pans creux
12	ZMU 34 0600	M6 DIN 934	Sechskantmutter	Nut	Écrou hexagonal
13	ZRG 28 0060	B6 DIN 127	Federring	Clip	Rondelle grover
14	ZSR 39 0620	M6x20 DIN 939	Stiftschraube	Stud	Goujon
15	ZMU 34 0800	M8 DIN 934	Sechskantmutter	Nut	Écrou hexagonal
16	ZSR 39 0825	M8x25 DIN 939	Stiftschraube	Stud	Goujon
17	ZSB 12 0805		Paßscheibe	Washer	Rondelle

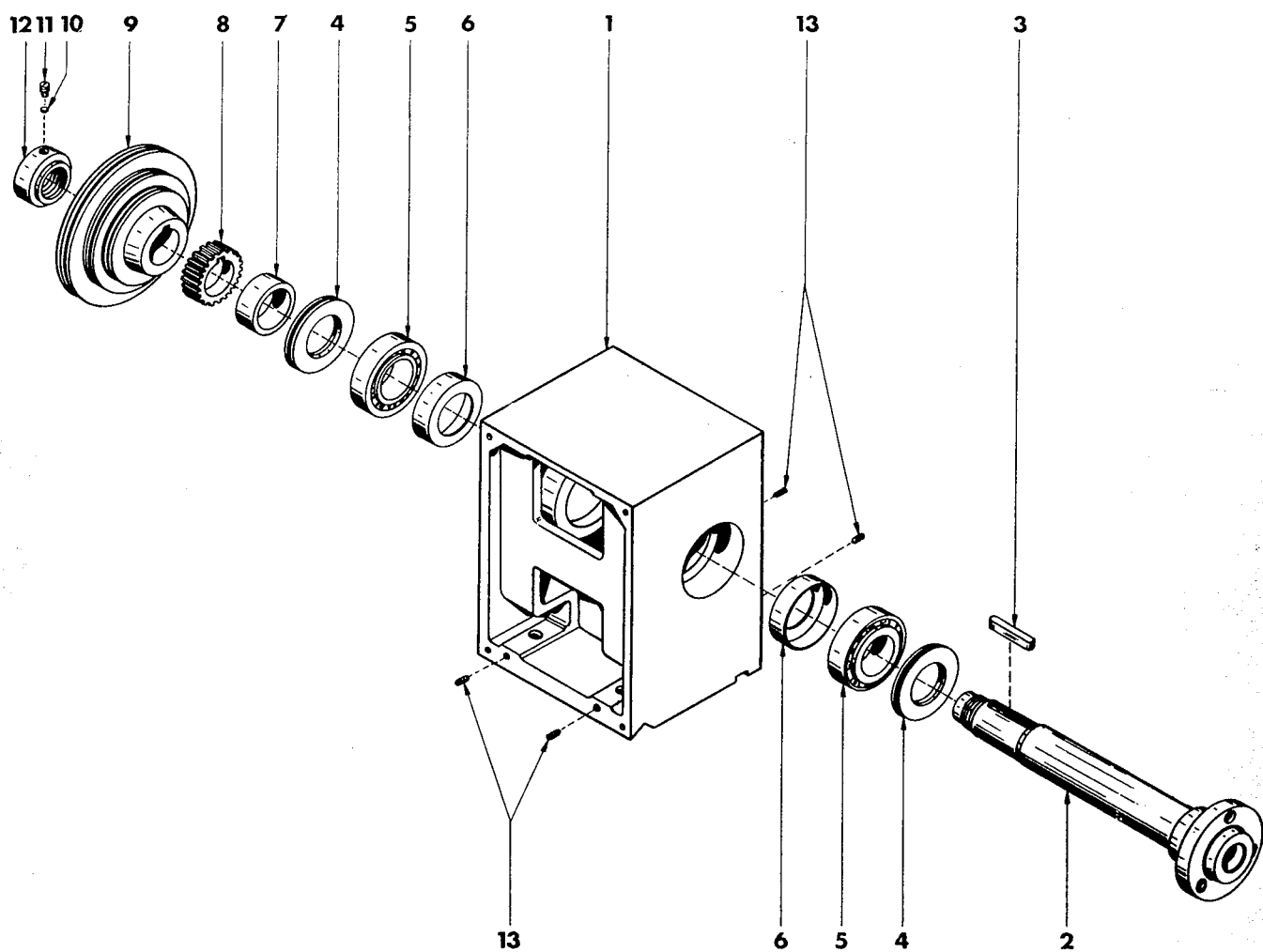

	B1A 030 000			G. Spindelstock	Headstock	Poupée fixe
Pos	Ref. No.	DIN		BENENNUNG	DESCRIPTION	DESIGNATION
1	B1A 030 010			Spindelstock	Headstock	Carter de poupée fixe
2	B1A 030 020			Spindel	Spindle	Broche principale
3	ZFD 85 8536	A8x5x36 DIN 6885		Paßfeder	Key	Clavette
4	B1A 030 050			Dichtscheibe	Gasket	Disque d'étanchéité
5	ZLG 32 0076	32007XC/P6		Kegelrollenlager	Heavy taper roller bearings	Roulement à rouleaux coniques
6	B1A 030 060			Deckel	Cover	Bouchon-cuvette
7	B1A 030 040			Distanzhülse	Bushing	Entretoise
8	B1A 030 030			Zahnrad	Gear	Engrenage
9	B1A 030 070			Riemenscheibe	Pulley	Poulie de broche
10	B2A 030 060			Druckscheibe	Disc	Pastille de pointeau
11	ZST 17 0405	M4x5 DIN 417		Gewindestift	Set screw	Vis pointeau
12	B2A 030 070			Spannmutter	Nut	Écrou canelé
13	ZST 51 0410	M4x10 DIN 551		Gewindestift	Set screw	Goujon

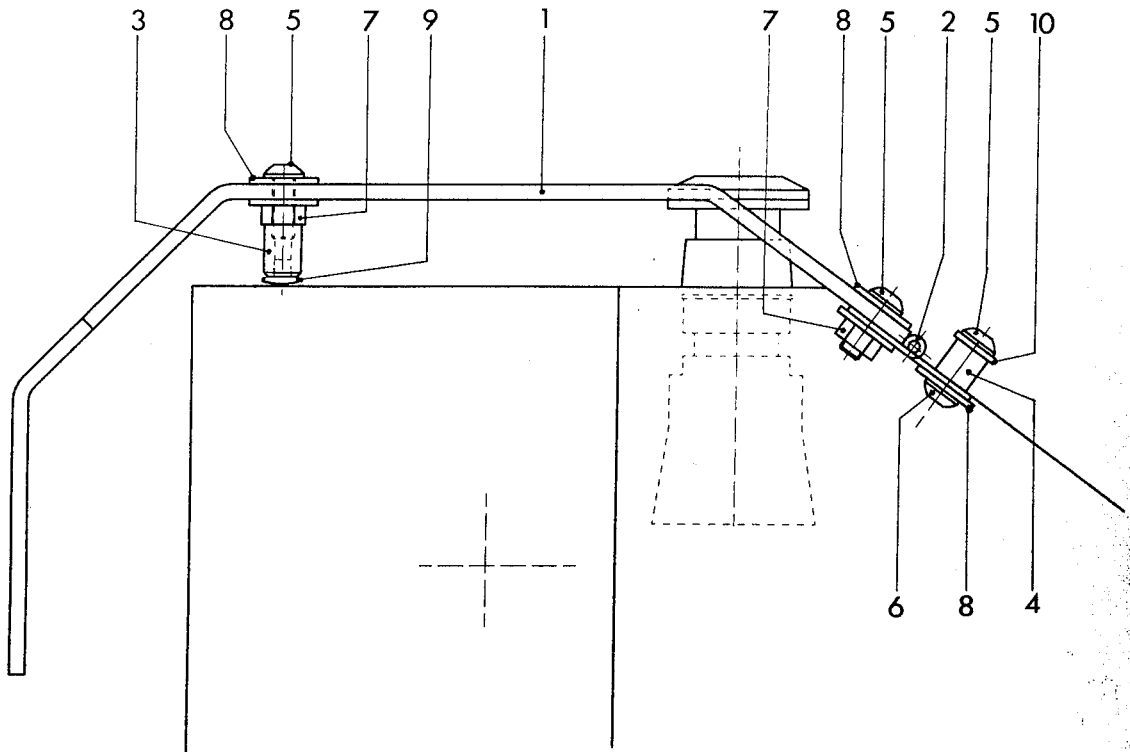

Pos.	Ref.No.	DIN	Benennung	Description	Designation
			<b>Futterschutz</b>	<b>Chuck guard</b>	<b>Protection de mandrin</b>
1	B1A 000 390		Schutz	Guard	Ecran de protection
2	B1P 100 110		Scharnier	Frame joint	Charnière
3	B1A 000 400		Bolzen	Bolt	Boulon
4	B1A 000 410		Träger	Support	Support
5	ZSR 880 616	M6x16-10.9	Linsenschraube	Filister head screw	Vis à tête lentiforme
6	ZSR 880 610	M6x10-10.9	Linsenschraube	Filister head screw	Vis à tête lentiforme
7	ZMU 340 600	M6 DIN934-6	Sechskantmutter	Hexagonal nut	Ecrou hexagonal
8	ZSB 210 640	A 6,4 DIN9021-ST	Scheibe	Washer	Rondelle
9	ZDK 504 052	TL-4-052	Verschlußstopfen	Plug	Bouchon fileté
10	ZSB 250 640	B6,4 DIN125-ST	Scheibe	Washer	Rondelle

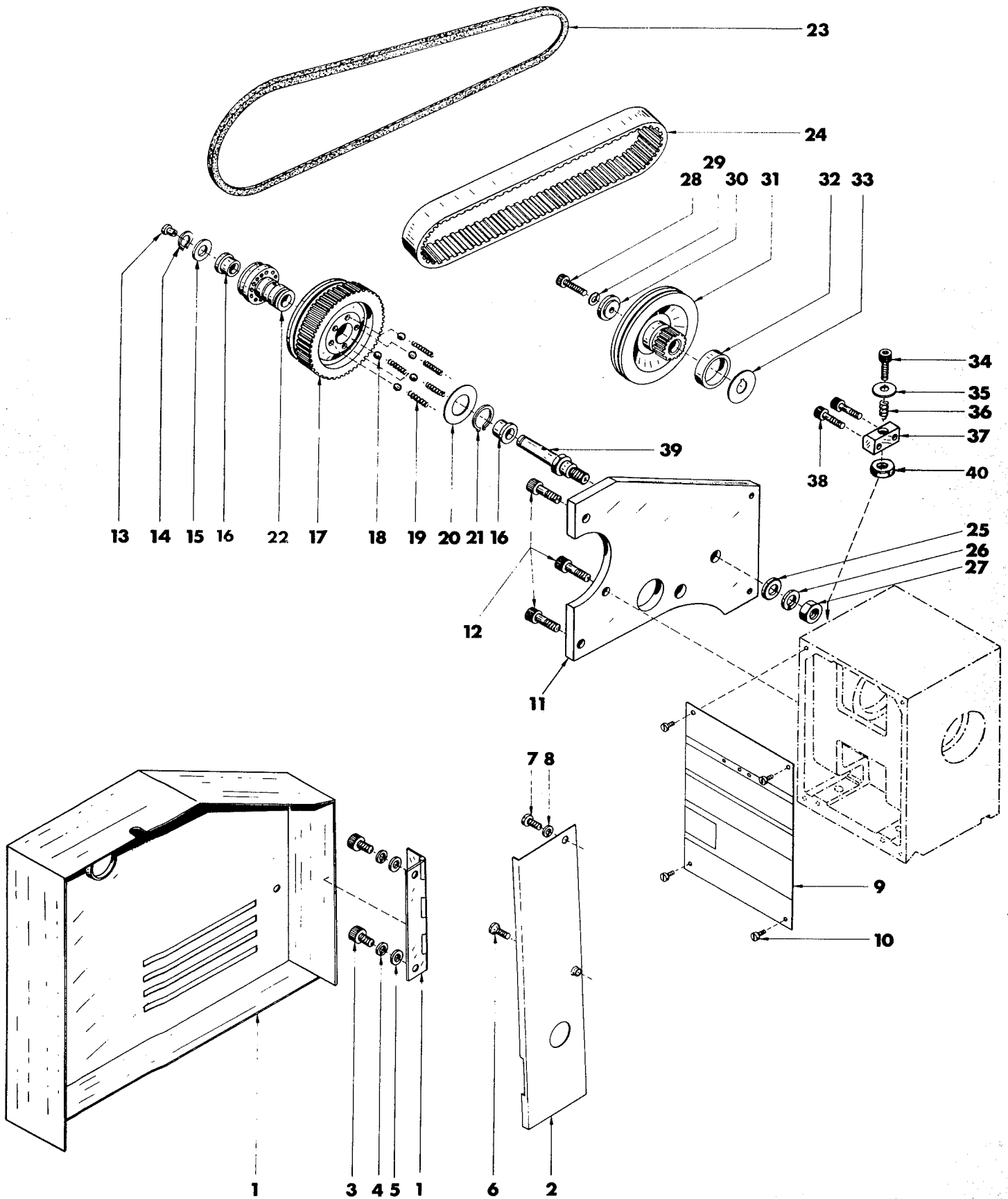

				Antrieb	Drive	Entrainement
Pos	Ref.No.	DIN		BENENNUNG	DESCRIPTION	DESIGNATION
1	B1A 060 000			G. Deckel	Cover	Couvercle assemblé
2	B1A 000 060			Abdeckblech	Covermount	Tôle de couverture
3	ZSR 12 0612	M6x12 DIN 912		Zylinderschraube	Round head screw	Vis tête cylindrique
4	ZRG 28 0060	B6 DIN 127		Federring	Clip	Rondelle grover
5	ZSB 25 0640	B6,4 DIN 125		Scheibe	Washer	Rondelle plate
6	ZSR 63 0512	M5x12 DIN 963		Senkschraube	Flat head screw	Vis tête fraisée
7	ZSR 94 0508	M5x8 DIN 84		Zylinderschraube	Round head screw	Vis tête cylindrique
8	ZSB 25 0530	B5,3 DIN 125		Scheibe	Washer	Rondelle grover
9	B1A 000 180			Frontschild metr. 50 Hz	Plate metr. 50 Hz	Plaque frontale metr. 50 Hz
	B1B 000 180			Frontschild metr. 60 Hz	Plate metr. 60 Hz	Plaque frontale metr. 60 Hz
	B1A 000 380			Frontschild inch 60 Hz	Plate inch 60 Hz	Plaque fr. en pouces 60 Hz
10	ZSR 84 0406	M4x6 DIN 84		Zylinderschraube	Round head screw	Vis tête cylindrique
11	B1A 210 000			G. Trägerplatte	Bracket plate	Plaque support assemblée
12	ZSR 12 0820	M8x20 DIN 912		Zylinderschraube	Round head screw	Vis tête cylindrique
13	ZNP 01 1000			Schmiernippel	Grease nipple	Graisser
14	ZRG 71 1210	12x1 DIN 471		Sicherungsring	Clips	Circlip
15	ZSB 10 2181	22x18x1		Stützscheibe	Washer	Rondelle plate
16	B1A 211 000			G. Kupplung	Clutch	Embrayage assemblé
17	B2A 030 130			Bundlager	Bearing bush	Palier d'assemblage
17	B1A 000 090			Vorgelegeriemenscheibe	Countershaft pulley	Poulie de renvoi pour courroie crantée
18	ZKG 00 1060	6,0GK3 DIN 5401		Stahlkugel	Ball	Bille acier
19	B1A 000 340			Druckfeder	Feed spring	Ressort de compression
20	ZLG 77 2542	AS 2542		Axiallagerscheibe	Thrust bearing washer	Disque
21	ZRG 71 2512	25x1,2 DIN 471		Sicherungsring	Clip	Circlip
22	B1A 000 320			Kupplungsriemenscheibe	Belt pulley	Poulie trapézoïdale de l'embrayage
23	ZRM 45 0690	Gates 5M-690		Keilriemen	Vee belt	Courroie trapézoïdale
24	ZRM 51 7170	170XL 050		Zahnriemen	Drive belt	Courroie crantée
25	ZSB 25 1050	B10,5 DIN 125		Scheibe	Washer	Rondelle plate
26	ZRG 28 0100	B10 DIN 127		Federring	Clip	Rondelle grover
27	ZMU 34 1000	M10 DIN 934		Sechskantmutter	Nut	Ecrou hexagonal
28	ZSR 12 0525	M5x25 DIN 912		Zylinderschraube	Round head screw	Vis tête cylindrique
29	ZRG 28 0050	B5 DIN 127		Federring	Clip	Rondelle grover
30	B1A 000 100			Scheibe	Washer	Rondelle plate épaulée
31-33	B1A 215 000			G. Motorriemenscheibe	Pulley	Poulie moteur assemblée
32	B1A 000 130			Anlauftring	Start sleeve	Douille entretoise
33	B1A 000 120			Anlaufscheibe	Spacer	Disque à rainure de clavette
34	ZSR 12 0620	M6x20 DIN 912		Zylinderschraube	Round head screw	Vis tête cylindrique
35	ZSB 21 0640	A6,4 DIN 9021		Scheibe	Washer	Rondelle plate
36	C3A 062 040			Druckfeder	Feed spring	Ressort de compression
37	B1A 000 050			Klemmleiste	Clamp piece	Lardon de blocage
38	ZSR 12 0622	M6x22 DIN 912		Zylinderschraube	Round head screw	Vis tête cylindriques
39	B1A 000 110			Riemenscheibenwelle	Belt pulley shaft	Arbre des poulies
40	ZMU 34 0600	M6 DIN 934		Sechskantmutter	Hexagon nut	Ecrou hexagonal

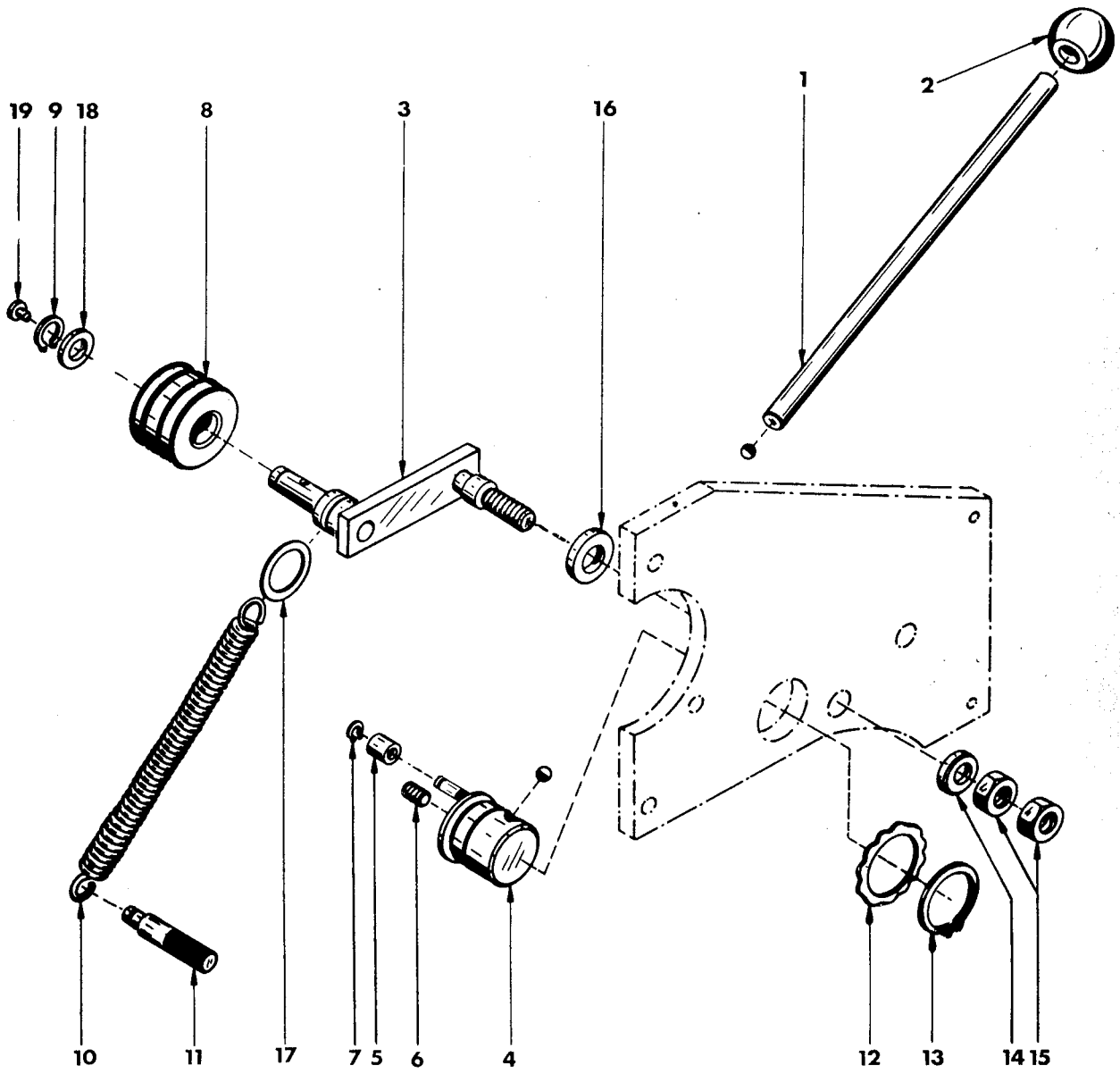



				Riemenspanner	Tensioning roller	Rouleau tendeur
Pos	Ref.No.	DIN		BENENNUNG	DESCRIPTION	DESIGNATION
1+2	B1A 213 000			G. Hebel	Lever	Levier
2	ZGF 20 3212	KK 32 - 12		Kugelknopf	Plastics ball	Sphère de matiere comprimée
3	B1A 190 000			G. Spannhebel	Lever	Levier
4-7	B1A 212 000			G. Drehbolzen	Bolt	Boulon
5	B1A 000 310			Hülse	Sleeve	Manchon
6	ZST 16 0812	AM 8x12 DIN 916		Gewindestift	Set screw	Vis pointeau
7	ZRG 71 0607	6x0,7 DIN 471		Sicherungsring	Clip	Bague fendue
8	B1A 214 000			G. Spannrolle	Roller	Rouleau
9	ZRG 71 1210	12x1 DIN 471		Sicherungsring	Clip	Bague fendue
10	B1A 000 150			Zugfeder	Spring	Ressort de traction
11	B1A 000 170			Bolzen	Bolt	Boulon
12	ZSB 02 6204	6204/K2		Ausgleichscheibe	Washer	Rondelle
13	ZRG 71 3717	37x1,75 DIN 471		Sicherungsring	Clip	Bague fendue
14	ZSB 25 1050	B10,5 DIN 125		Scheibe	Washer	Rondelle
15	ZMU 34 1000	M10 DIN 934		Sechskantmutter	Nut	Ecrou
16	B1A 000 290			Scheibe	Washer	Rondelle
17	ZSB 12 2601	PS 26x37x1		Paßscheibe	Washer	Rondelle
18	ZSB 10 2181	SS 12x18x1,2		Stützscheibe	Washer	Rondelle
19	ZNP 01 1000			Schmiernippel	Grease nipple	Graisseur

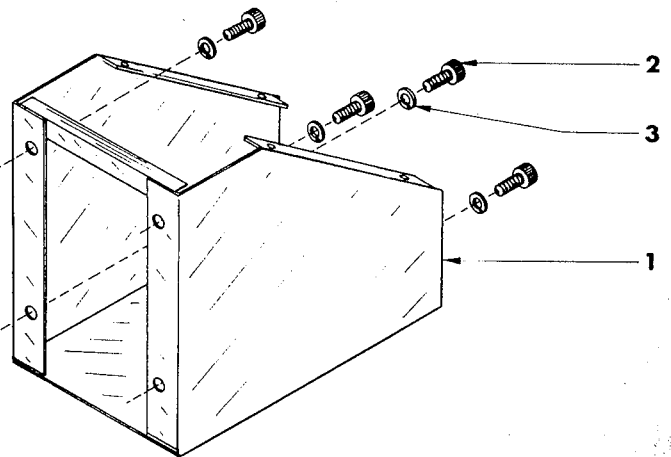
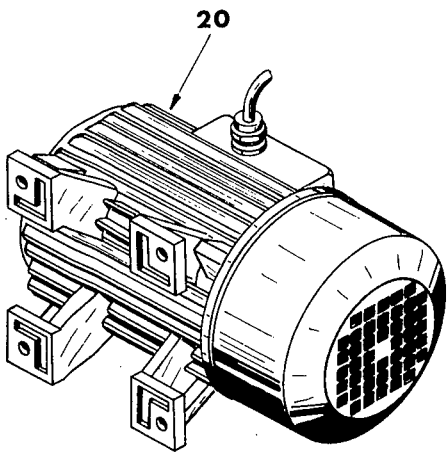
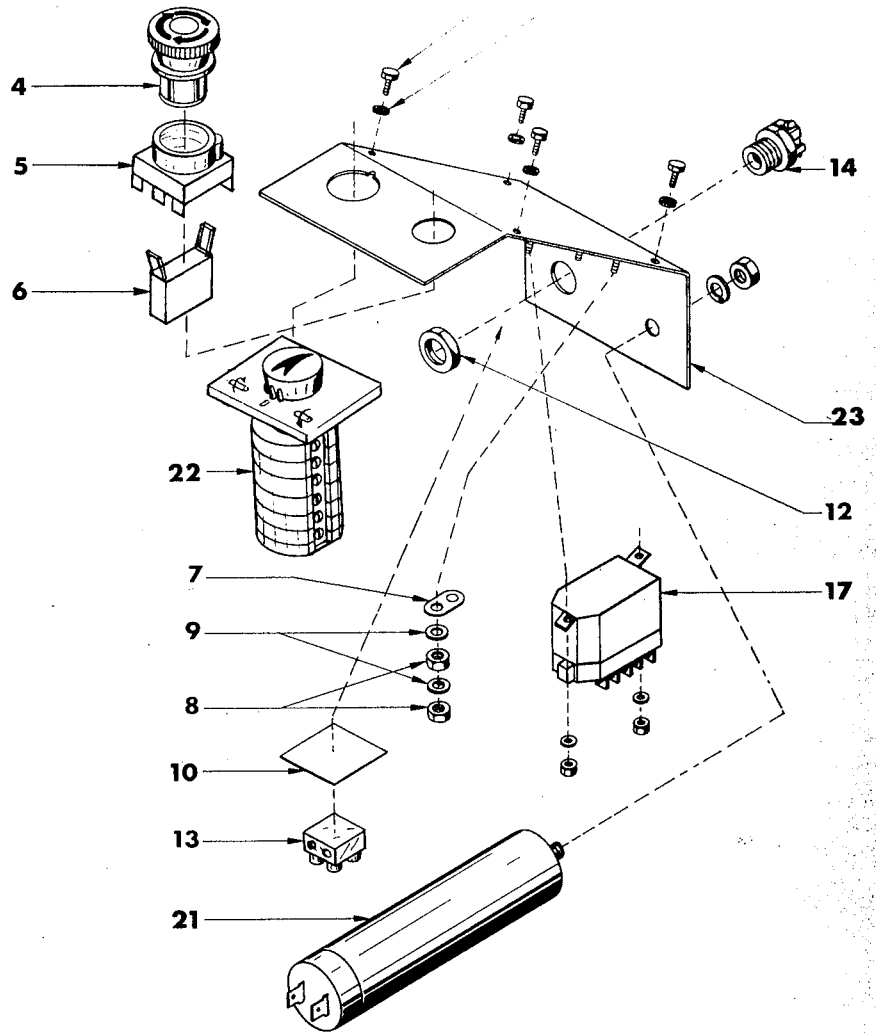

				E-Ausrüstung	Electrical equipment	Equipement électrique
Pos.	Ref.No.	DIN		Benennung	Description	Designation
1	B1A 170 000			Gr. E-Gehäuse	E-housing compl.	Ens. boîtier électrique
2	ZSR 120 612	M6x12 DIN 912		Zylinderschraube	Socket head screw	Vis 6 pans creux
3	ZRG 280 060	B6 DIN127		Federring	Clip	Ressort élastique
4	ZEL 401 010*			NOT AUS Taste	Emergency off button	Touche arrêt d'urgence
5	ZEE 710 701*			Kupplung	Coupling	Pièce d'intermédiaire
6	ZEL 491 040*			Unterbrecher	Contact unit	Unité de contact
7	H1E 100 010			Erdungsschild	Grounding plate	Lardon prise de terre
8	ZMU 340 401	M4 DIN934		Sechskantmutter	Hexagon nut	Ecrou hexagonal
9	ZSB 970 430	A4,3 DIN6797		Zahnscheibe	Serrated lock washer	Rondelle dentée
10	B1A 100 020			Isolierplatte	Insulating plate	Plaque d'isolation
12	ZGP 201 100	PG11		Gegenmutter	Lock nut	Contre-écrou
13	ZEL 010 002			Bruchklemme	Breakage clamp	Borne de rupture
14	ZPG 100 007	MZB 11		PG-Verschraubung	Screw coupling	Raccordement à vis
15	ZSR 330 508	M5x8 DIN933		Sechskantschraube	Hexagon head screw	Vis hexagonal
16	ZSB 980 530	A5,3 DIN6798		Fächerscheibe	Serrated lock washer	Rondelle éventail
17	ZEL 115 220*			Schütz	Relay	Relais

\*...nur CE-Variante

Variante	Spannung	Frequenz	Pos. 20 Motor	Pos. 21 Kondensator	Pos. 22 Schalter	Pos. 23 E-Deckel	
Variant	Voltage	Frequency	Pos. 20 motor	Pos. 21 condenser	Pos. 22 switch	Pos. 23 Roofing	
Variante	Tension	Frequence	Pos. 20 moteur	Pos. 21 condensateur	Pos. 22 interrupteur	Pos. 23 Couvercle	
Standard	220-240V	50 Hz	ZMO 951 220	ZKO 240 120	12 $\mu$ F	ZEL 223 318	B1A 101 001
CE	220-240V	50 Hz	ZMO 951 220	ZKO 240 120	12 $\mu$ F	ZEL 224 348	B1U 101 001
CSA, USA	115V	60 Hz	ZMO 941 115	ZKO 240 400	40 $\mu$ F	ZEL 223 318	B1C 100 042
Japan	100V	50 Hz	ZMO 951 100	ZKO 226 500	50 $\mu$ F	ZEL 223 318	B1C 100 042



				Räderschere	Quadrant	Lyre
Pos	Ref.No.	DIN		BENENNUNG	DESCRIPTION	DESIGNATION
1	B1A 000 010			Schere	Quadrant	Lyre nue
2	ZSR 12 0630	M6x30 DIN 912		Zylinderschraube	Flat head screw	Vis tête cylindrique
3	B2A 000 300			Scheibe	Washer	Rondelle plate
4	B2A 000 310			Keilhülse	Bush	Douille - clavette
5	B2A 000 350			Scherstift	Bushing	Goupille de cisaillement
6	B2A 000 270			Wechselrad 80	Gear 80	Engrenage 80 dents
7	B2A 000 280			Zwischenring	Bushing	Douille - entretoise
8	B2A 000 450			Sicherungsring	Clip	Rondelle fer à cheval
9	ZSR 33 0610	M6x10 DIN 933		Sechskantschraube	Hexagonal screw	Vis tête hexagonale
10	B2Z 200 010			Wechselrad 25	Gear 25	Engrenage 25 dents
11	B2A 000 270			Wechselrad 80	Gear 80	Engrenage 80 dents
12	B1A 000 190			Zahnrad 80	Gear 80	Engrenage 80 dents
13	B2Z 200 020			Wechselrad 30	Gear 30	Engrenage 30 dents
14	B2A 000 310			Keilhülse	Bush	Douille - clavette
15	B2A 071 020			Scheibe	Washer	Rondelle plate
16	B2A 071 040			Nutenstein	T-nut	Ecrou en T
17	B1A 000 020			Scherbolzen	Shaft	Boulon-axe
18	B1A 000 040			Scheibe	Washer	Rondelle fer à cheval
19	ZNP 01 1000			Schmiernippel	Grease fitting	Graisseur

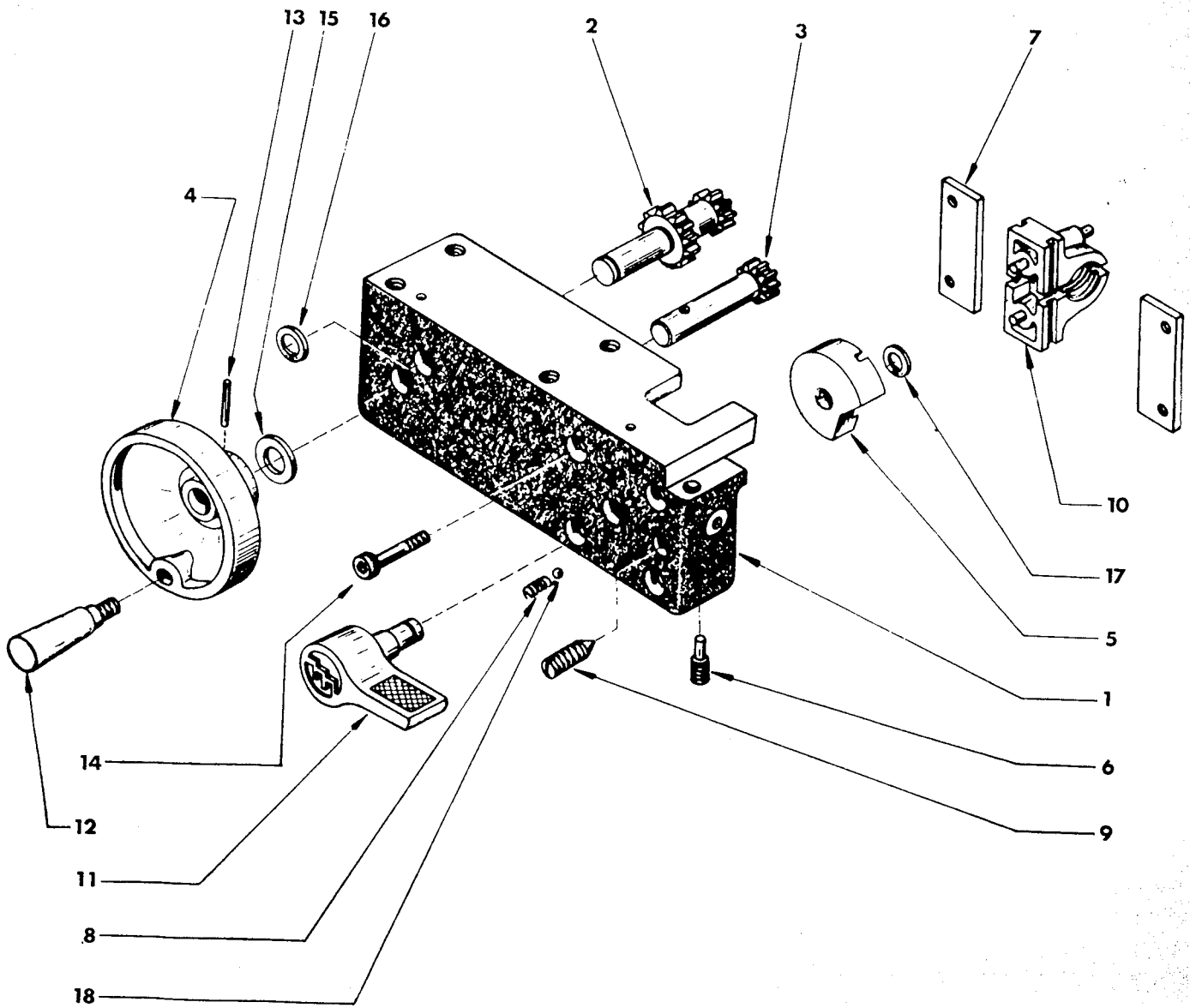
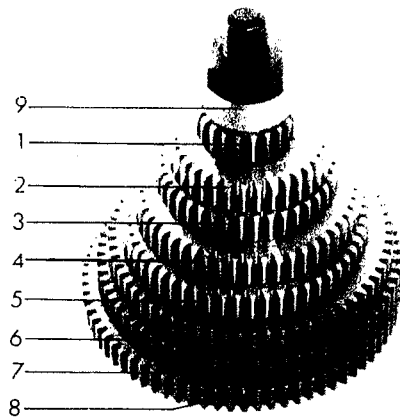

	700 010			G. Rädersatz	Set of change gears	Jeu d'engrenages assembles
Pos	Ref.No.	DIN		BENENNUNG	DESCRIPTION	DESIGNATION
1	B2A 000 250			Wechselrad Z = 20	Change gear	Engrenage 20 dents
2	B2A 000 290			Wechselrad Z = 35	Change gear	Engrenage 35 dents
3	B2Z 200 030			Wechselrad Z = 40	Change gear	Engrenage 40 dents
4	B2Z 200 050			Wechselrad Z = 50	Change gear	Engrenage 50 dents
5	B2Z 200 060			Wechselrad Z = 55	Change gear	Engrenage 55 dents
	B2Z 200 070			Wechselrad Z = 60	Change gear	Engrenage 60 dents
6	B2Z 200 080			Wechselrad Z = 65	Change gear	Engrenage 65 dents
7	B2Z 200 090			Wechselrad Z = 70	Change gear	Engrenage 70 dents
8	B2A 000 260			Wechselrad Z = 75	Change gear	Engrenage 75 dents
9	B2A 000 280			Zwischenring	Bushing	Douille-entretoise

				G. Schloßplatte	Apron	Tablier assemble
Pos	Ref.No.	DIN		BENENNUNG	DESCRIPTION	DESIGNATION
1	B2A 010 010			Schloßplatte	Apron casting	Tablier nu
2	B2A 010 020			Zwischenrad	Gear	Pignon double intermédiaire
3	B2A 010 030			Ritzel	Shaft gear	Pignon du volant
4	B4A 010 011			Handrad	Hand wheel	Volant
5	B2A 010 050			Schloßscheibe	Locking cam	Verrou de la noix
6	B2A 010 060			Nachstellschraube	Adjusting screw	Vis-pointeau de réglage
7	B2A 010 070			Führungsschiene	Guide	Languettes de guidage
8	H1A 000 380			Druckfeder	Feed spring	Ressort de compression
9	B2A 010 090			Einstellschraube	Adjusting screw	Vis-pointeau de réglage
10	B2A 011 000			Gr. Schloßmutter metr.	Half nut metr.	Noix = 2 demi-noix metr.
	B2B 011 000			Gr. Schloßmutter USA	Half nut USA	Noix = 2 demi noix USA
11	B2A 012 000			Gr. Schloßhebel	Handle	Levier d'enclenchement assemblé
12	C6A 130 000			Gr. Kegelgriff	Handle	Manneton assemblé
13	ZHL 81 0322	3x22 DIN 1481		Spannhülse	Grooved pin	Goupille fendue
14	ZSR 12 0630	M6x30 DIN 912		Innensechskantschraube	Allen head screw	Vis tête six pans creux
15	ZFD 93 2001	20x10,2x0,9 DIN 2093		Tellerfeder	Spring washer	Rondelle assiette
16	ZRG 21 0100	WR 10		Sprengring	Clip	Rondelle grower
17	ZRG 21 0080	WR 8		Sprengring	Clip	Rondelle grower
18	ZKG 00 1040	4,0GK3 DIN 5401		Stahlkugel	Ball	Bille acier

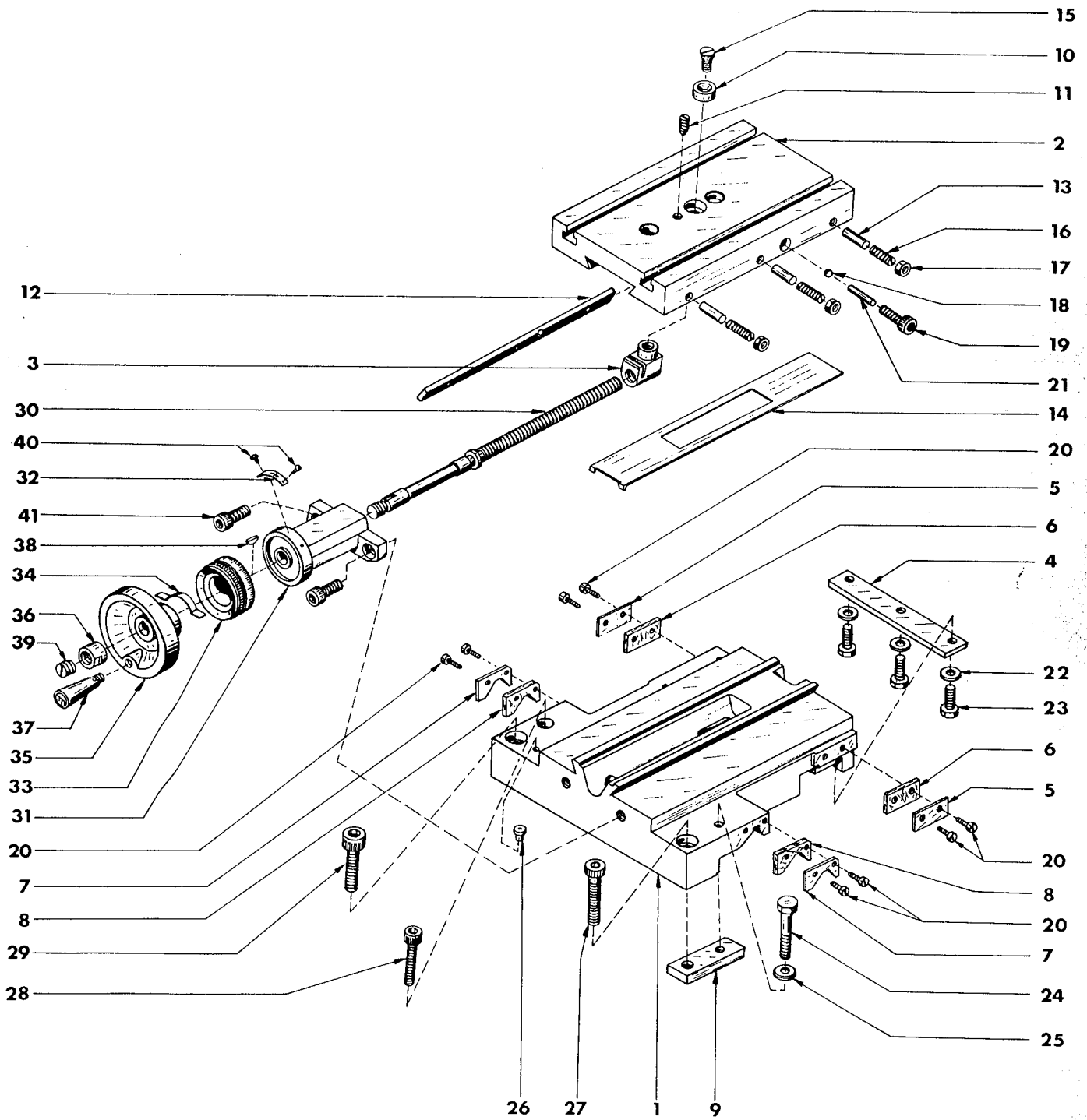



				Längs- und Querschlitzen	Saddle and Cross Slide	Trainard et chariot transversal
Pos	Ref.No.	DIN		BENENNUNG	DESCRIPTION	DESIGNATION
1	B4A 000 110			Schlitten	Carriage	Trainard nu
2	B4A 000 120			Querschlitzen	Cross-slide-table	Transversal nu
3	B2A 000 130			Quermutter metr.	Cross-slide-nut metr.	Noix du transversal metr.
	B2B 000 130			Quermutter USA	Cross-slide-nut USA	Noix du transversal USA
4	B2A 000 180			Bettleiste	Gib	Languette de guidage
5	B4A 000 170			Abstreifer	Cover mount	Plaquette couvre-racleur
6	B4A 000 180			Abstreiffilz	Way cover	Racleur en feutre
7	B4A 000 190			Abstreifer	Cover mount	Plaquette couvre-racleur
8	B4A 000 200			Abstreiffilz	Way cover	Racleur en feutre
9	B2A 000 660			Klemmstück	Binding piece	Plaque de blocage
10	B2A 000 150			Senkscheibe	Bushing	Douille fraisée
11	B2A 000 140			Nachstellschraube	Adjusting screw	Vis-pointau de réglage
12	B2A 000 210			Einstelleiste	Gib	Lardon de réglage
13	B2A 000 220			Druckstift	Stud	Cheville de pression
14	B4A 000 240			Deckblech	Cover mount	Tôle de recouvrement
15	ZSR 63 0612	M6x12 DIN 963		Senkschraube	Flat head screw	Vis tête fraisée
16	ZST 51 0412	M4x12 DIN 551		Gewindestift	Set screw	Vis de réglage
17	ZMU 34 0400	M4 DIN 934		Sechskantmutter	Nut	Contre-écrou
18	ZKG 00 2316	3/16GK3 DIN5401		Stahlkugel	Ball	Bille acier
19	ZSR 12 0616	M6x16 DIN 912		Innensechskantschraube	Allen head screw	Vis tête 6 pans creux
20	ZSR 84 0408	M4x8 DIN 84		Zylinderschraube	Flat head screw	Vis tête cylindrique
21	ZST 08 0512	548x12 DIN 7		Zylinderstift	Flat screw	Cheville
22	ZSB 25 0530	B5,3 DIN 125		Scheibe	Washer	Rondelle plate
23	ZSR 33 0516	M5x16 DIN 933		Sechskantschraube	Hexagon head screw	Vis tête hexagonale
24	ZSR 31 0635	M6x35 DIN 931		Sechskantschraube	Hexagon head screw	Vis tête hexagonale
25	ZSB 25 0640	B6,4 DIN 125		Scheibe	Washer	Rondelle plate
26	ZNP 01 1000			Schmiernippel	Grease fitting	Graisser
27	ZSR 12 0835	M8x35 DIN 912		Innensechskantschraube	Allen head screw	Vis tête 6 pans creux
28	ZSR 12 0630	M6x30 DIN 912		Innensechskantschraube	Allen head screw	Vis tête 6 pans creux
29	ZSR 12 0830	M8x30 DIN 912		Innensechskantschraube	Allen head screw	Vis tête 6 pans creux
	B4A 020 000			G.Querspindel metr.	Lead screw compl. metr.	Broche de commande du transversal n
	B4B 020 000			G.Querspindel USA	Lead screw compl. USA	Broche de commande du transversal L
30	B4A 020 010			Querspindel metr.	Lead screw metr.	Broche de commande du transversal n
	B4B 020 010			Querspindel USA	Lead screw USA	Broche de commande du transversal L
31	B4A 020 020			Querspindelträger	Lead screw mount	Support-palier de broche
32	B2A 000 060			Skalenschild metr.	Plate metr.	Plaquette graduée metr.
	B2B 040 030			Skalenschild USA	Plate USA	Plaquette graduée USA
33	B4A 020 030			Skalenring metr.	Micrometer collar metr.	Vernier metr.
	B4B 020 030			Skalenring USA	Micrometer collar USA	Vernier USA
34	B2A 000 080			Bogenfeder	Spring	Lame ressort courbe
35	B2A 000 070			Handrad	Handwheel	Volant
36	B2A 000 100			Mutter	Nut	Ecrou 2 pans
37	C6A 130 000			Gr. Kegelgriff	Handle	Manneton
38	ZFD 88 0337	3x3,7 DIN 6888		Scheibenfeder	Key	Clavette demi-lune
39	ZST 51 0806	M8x6 DIN 551		Gewindestift	Set screw	Vis-pointau de réglage
40	ZNA 76 0144	1,4x4 DIN 1476		Kerbnagel	Rivet	Rivet
41	ZSR 12 0616	M8x16 DIN 912		Innensechskantschraube	Allen head screw	Vis tête 6 pans creux

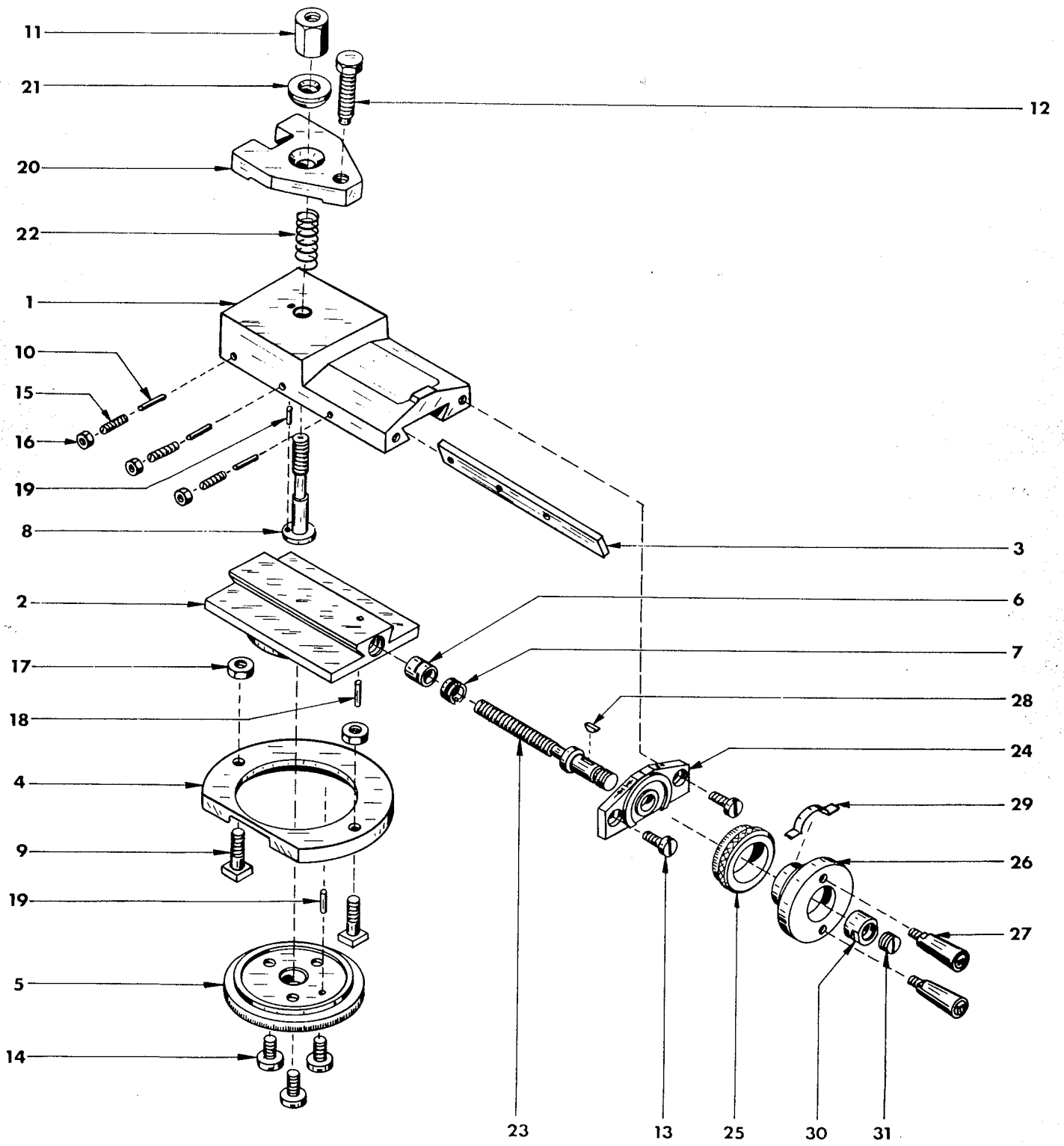

				G. Obersupport	Compound	Chariot supérieur
Pos	Ref.No.	DIN		BENENNUNG	DESCRIPTION	DESIGNATION
1	B4A 050 010			Obersupport	Compound	Chariot supérieur nu
2	B2A 050 020			Oberplatte	Swivel base	Support-glissière
3	B2A 050 030			Einstelleiste	Gib	Lardon de réglage
4	B2A 050 041			Klemmring	Clamping ring	Bague de blocage
5	B2A 050 050			Skalenring	Micrometer collar	Embase graduée
6	B2A 050 060			Obermutter metr.	Lead screw nut metr.	Noix metr.
	B2B 050 060			Obermutter USA	Lead screw nut USA	Noix USA
7	B2A 050 070			Einstellschraube	Adjusting screw	Bague-écrou de réglage
8	B4A 050 080			Schraube	Screw	Boulon de fixation du porte-outil
9	B2A 050 090			Nutenschraube	T-nut screw	Boulon en T
10	B2A 050 100			Druckstift	Stud	Cheville
11	B2A 040 100			Sechskantmutter	Nut	Ecrou hexagonal
12	ZSR 61 0830	AM8x30 DIN 561		Sechskantschraube	Hexagon head screw	Vis à tête hexagonale
13	ZSR 84 0512	M5x12 DIN 84		Zylinderschraube	Flat head screw	Vis tête cylindrique
14	ZSR 84 0610	M6x10 DIN 84		Zylinderschraube	Flat head screw	Vis tête cylindrique
15	ZST 51 0410	M4x10 DIN 551		Gewindestift	Set screw	Vis-pointau de réglage
16	ZMU 34 0400	M4 DIN 934		Sechskantmutter	Nut	Contre-écrou
17	ZMU 34 0600	M6 DIN 934		Sechskantmutter	Nut	Ecrou hexagonal
18	ZHL 81 0212	2x12 DIN 1481		Spannhülse	Lock pin	Goupille fendue
19	ZHL 81 0312	3x12 DIN 1481		Spannhülse	Lock pin	Goupille fendue
20	B4A 050 110			Spannklaue	Tool clamp	Bride de serrage d'outil
21	B4A 050 120			Ballenscheibe	Washer	Rondelle sphérique
22	B4A 050 130			Druckfeder	Spring	Ressort de compression
	B4A 051 000			G.Oberspindel metr.	Lead screw metr.	Broche du chariot supérieur assemblee metr.
	B4B 051 000			G.Oberspindel USA	Lead screw USA	Broche du chariot supérieur assemblee USA
23	B2A 051 010			Oberspindel metr.	Lead screw metr.	Broche nue metr.
	B2B 051 010			Oberspindel USA	Lead screw USA	Broche nue USA
24	B2A 051 020			Oberspindelträger metr.	Lead screw mount metr.	Palier-support de broche metr.
	B2B 051 020			Oberspindelträger USA	Lead screw mount USA	Palier-support de broche USA
25	B2A 020 030			Skalenring metr.	Micrometer collar metr.	Vernier metr.
	B2B 020 030			Skalenring USA	Micrometer collar USA	Vernier USA
26	B4A 051 010			Handrad	Handwheel	Volant
27	B2A 051 040			Kegelgriff	Handle	Manneton
28	ZFD 88 0337	3x3,7 DIN 6888		Scheibenfeder	Key	Clavette demi-lune
29	B2A 000 080			Bogenfeder	Spring	Lame ressort courbe
30	B2A 000 100			Mutter	Nut	Ecrou 2 pans
31	ZST 51 0806	M8x6 DIN 551		Gewindestift	Set screw	Vis de réglage

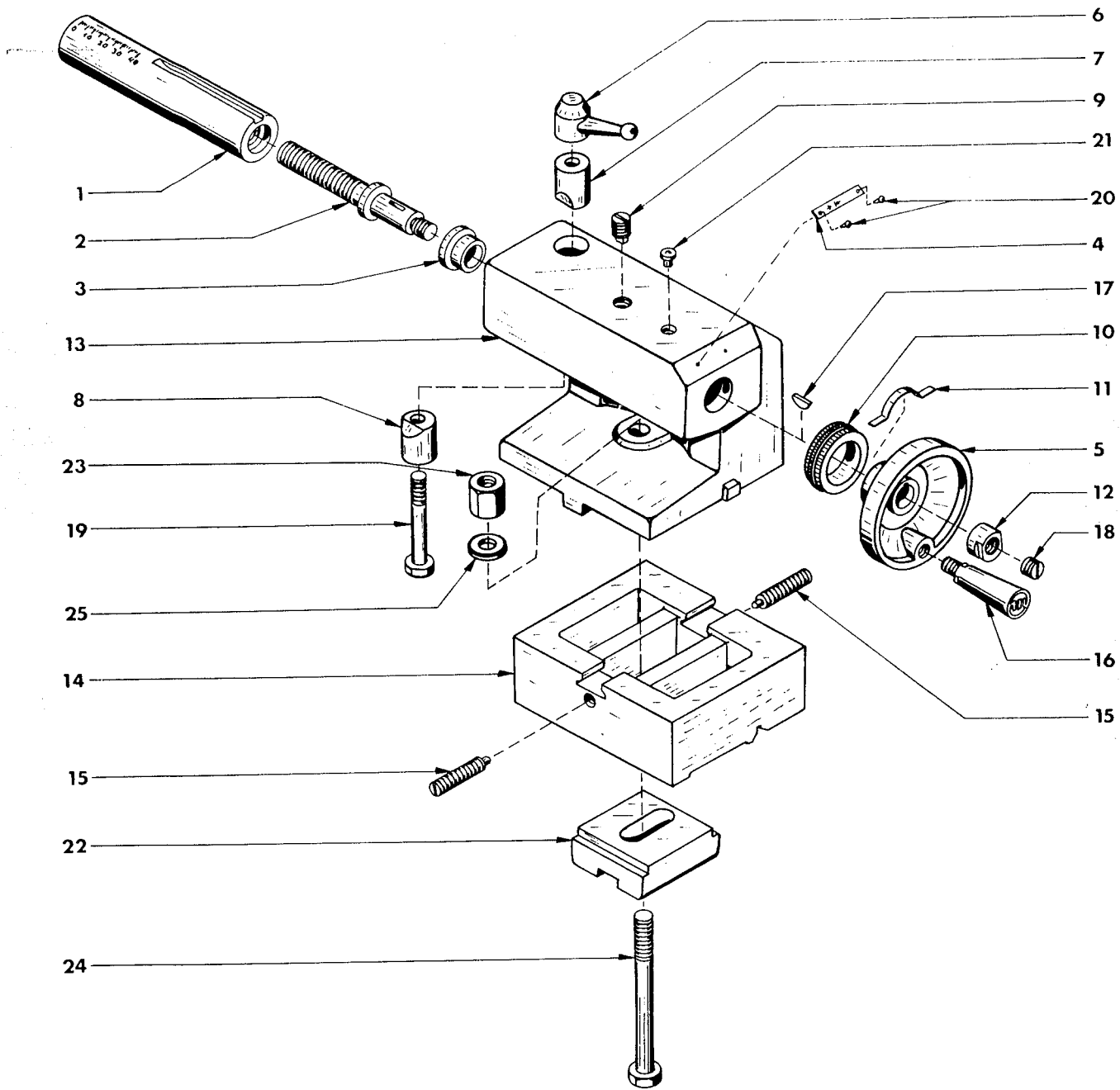

Pos.	Ref.No.	DIN	Benennung	Description	Designation
			<b>G. Reitstock</b>	<b>Tailstock compl.</b>	<b>Poupée mobile assemblée</b>
1	B4A 044 000 B4B 044 000		Reitstockpinole metr. Reitstockpinole USA	Tailstock ram metr. Tailstock ram USA	Canon metr. Canon USA
2	B2A 040 020 B2B 040 020		Triebsschraube metr. Triebsschraube USA	Lead screw metr. Lead screw USA	Broche metr. Broche USA
3	B2A 040 030		Bundbüchse	Bushing	Douille d'assemblage
4	B2A 000 060 B2B 040 030		Skalenschild metr. Skalenschild USA	Plate metr. Plate USA	Plaquette graduée metr. Plaquette graduée USA
5	B4A 040 010		Handrad	Handwheel	Volant
6	B2A 040 050		Knebelgriff	Lever	Levier de blocage du canon
7	B2A 040 060		Klemmbacke	Clamp	Mors de blocage supérieur
8	B2A 040 070		Klemmstück	Binding piece	Mors de blocage inférieur
9	B2A 040 080		Führungsschraube	Guide pin	Vis de guidage
10	B2A 000 090 B2B 020 030		Skalenring metr. Skalenring USA	Micrometer collar metr. Micrometer collar USA	Bague du vernier metr. Bague du vernier USA
11	B2A 000 080		Bogenfeder	Feed spring	Lame ressort courbe
12	B2A 000 100		Mutter	Nut	Ecrou 2 pans
13-15	B4A 041 000		G. Reitstockplatte	Tailstock base compl.	Embase de la contre- poupée assemblée
13	B2A 041 010		Reitstock	Tailstock	Corps de la contre- poupée nue
14	B4A 041 020		Reitstockplatte	Tailstock base	Embase nue
15	ZST 17 0630	M6x30 DIN417	Gewindestift	Set screw	Vis de réglage antérieure ou postérieure
16	C8A 130 000		Kegelgriff	Handle	Manneton
17	ZFD 88 0037	3x3,7 DIN6888	Scheibfeder	Key	Clavette demi-lune
18	ZST 51 0806	M8x6 DIN551	Gewindestift	Set screw	Vis de réglage
19	ZSR 31 0650	M6x50 DIN931	Sechskantschraube	Hexagonal screw	Boulon tête hexagonale
20	ZNA 76 0144	1,4x4 DIN1476	Kerbnagel	Rivet	Rivét
21	ZNP 01 1000		Schmiernippel	Grease fitting	Graisseur
22	B2A 040 090		Klemmplatte	Clamping plate	Plaque de blocage
23	B2A 040 100		Mutter	Nut	Ecrou 2 pans
24	ZSR 310 890	M8x90 DIN931	Schraube	Screw	Vis
25	ZSB 250 840	8,4 DIN125	Scheibe	Washer	Rondelle

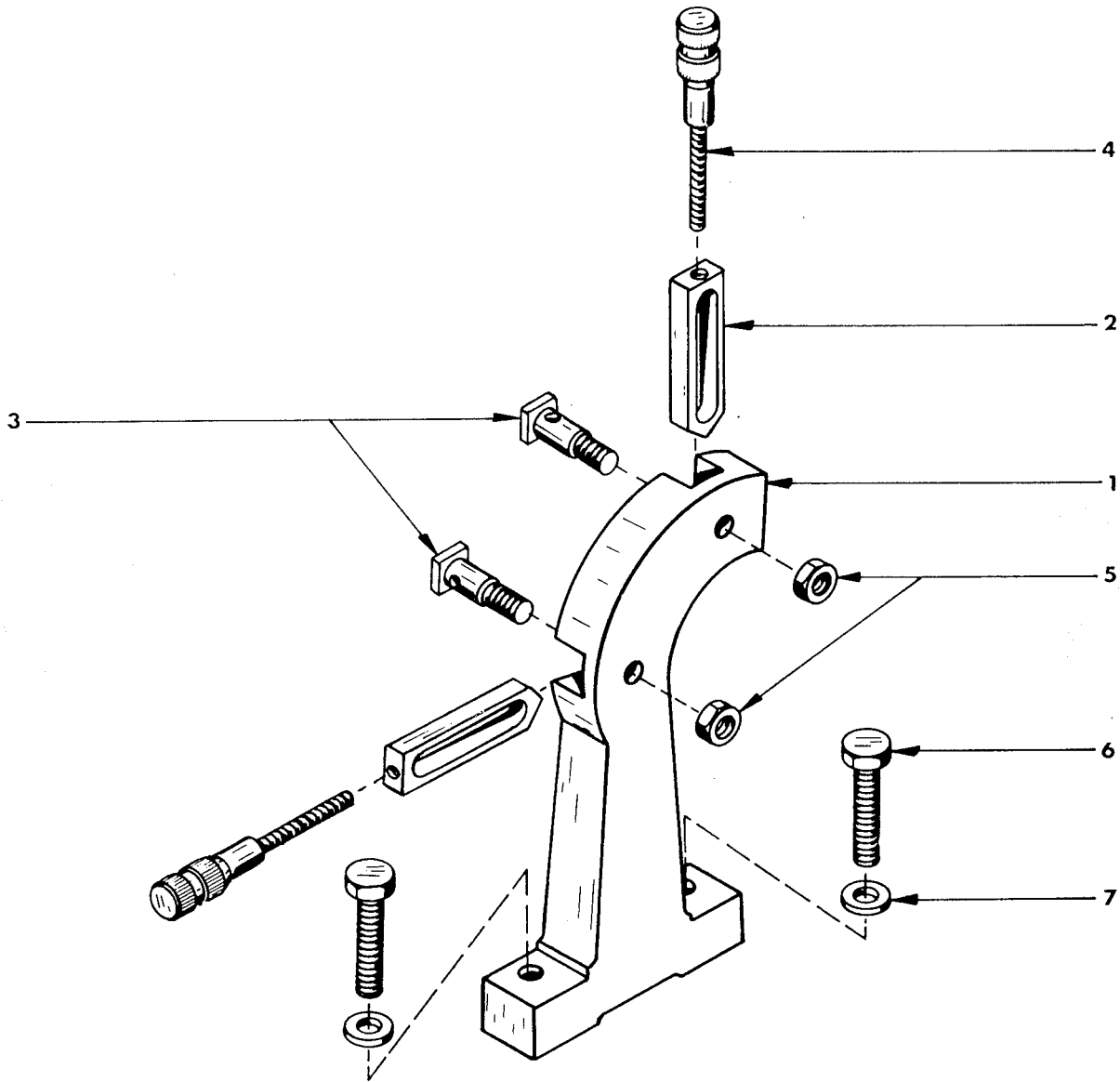

	743 800			G. Laufflünette	Follower rest	Lunette a suivre
Pos	Ref.No.	DIN		BENENNUNG	DESCRIPTION	DESIGNATION
1	B4Z 230 010/1			Laufflünette	Housing	Corps
2	B2Z 230 020			Gleitbacke	Jaw	Touche
3	B2Z 230 030			Nutschraube	Screw	Boulon en T
4	B2Z 230 040			Stellschraube	Thumb screw	Vis tête moletée
5	ZMU 34 0800	M8 DIN 934		Sechskantmutter	Nut	Ecrou hexagonal
6	ZSR 33 0625	M6x25 DIN 933		Sechskantschraube	Hexagonal screw	Vis tête hexagonale
7	ZSB 25 0640	B6,4 DIN 125		Scheibe	Washer	Rondelle plate

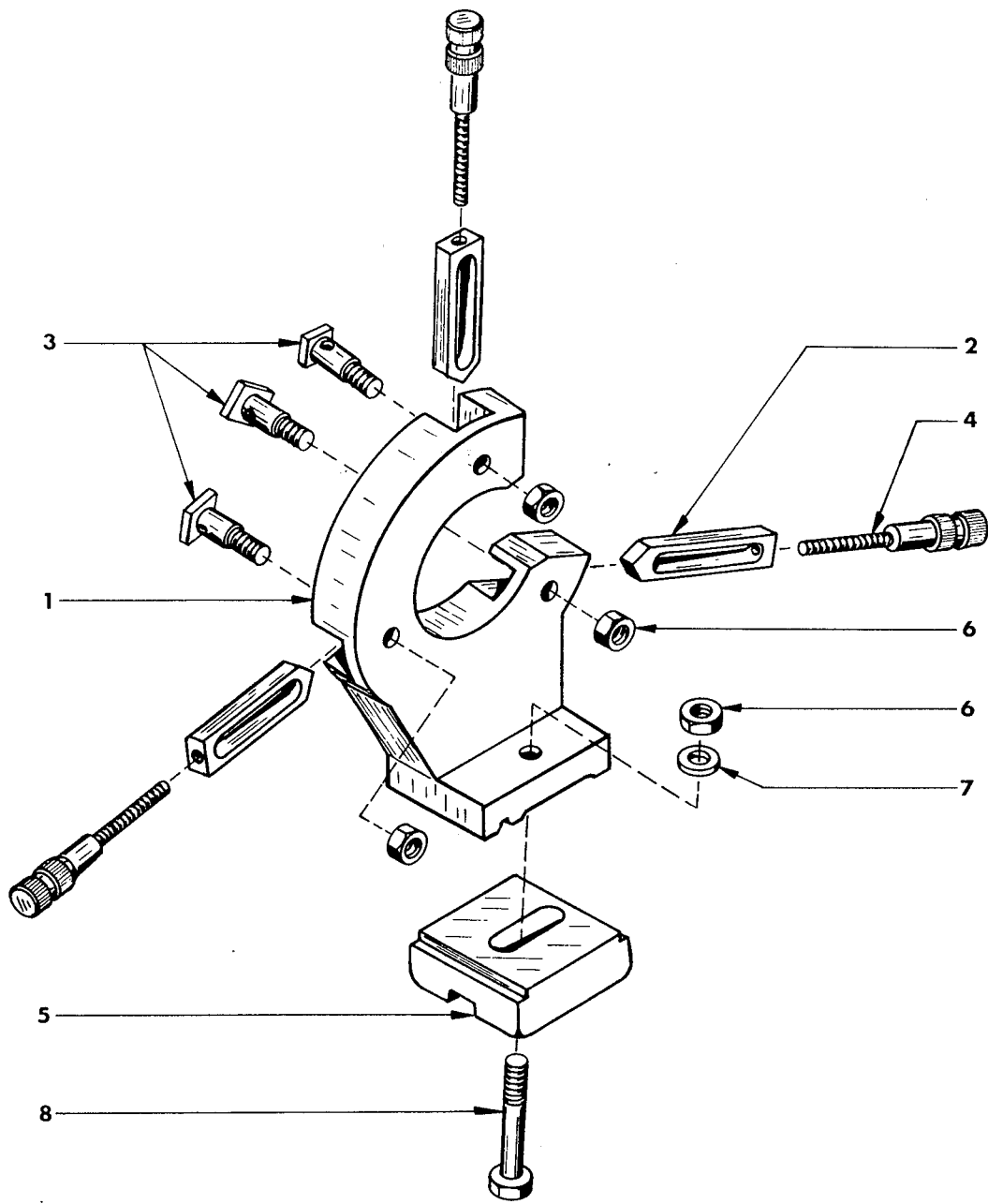

	742 800			G. Stehlünette	Steady rest	Lunette fixe
Pos	Ref.No.	DIN		BENENNUNG	DESCRIPTION	DESIGNATION
1	B4Z 240 010/1			Stehlünette	Housing	Corps
2	B2Z 230 020			Gleitbacke	Jaw	Touche
3	B2Z 230 030			Nutschraube	Screw	Boulon en T
4	B2Z 230 040			Stellschraube	Thumb screw	Vis tête moletée
5	B2A 040 090			Klemmplatte	Clamping plate	Contre-plaque de blocage
6	ZMU 34 0800	M8 DIN 934		Sechskantmutter	Nut	Ecrou hexagonal
7	ZSB 25 0840	B8,4 DIN 125		Scheibe	Washer	Rondelle plate
8	ZSR 31 0850	M8x50 DIN 931		Sechskantschraube	Hexagonal screw	Boulon tête hexagonale

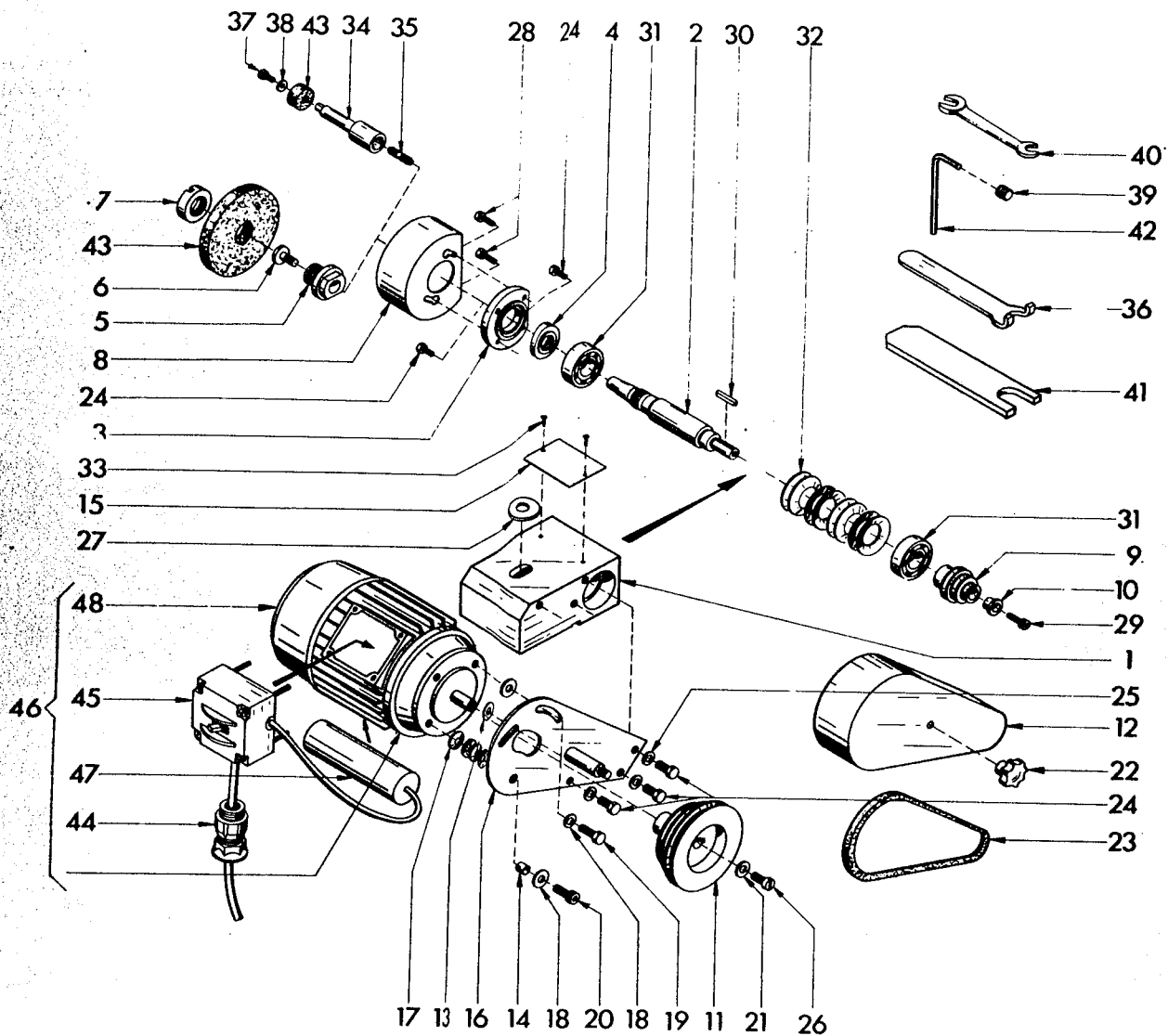

Spannung Voltage (V) Tension	Frequenz Frequency Frequence	Ref. Nr. für Motor Ref. Nr. for motor Ref. Nr. moteur	Ref. Nr. für Kondensator Ref. Nr. for condenser Ref. Nr. condensateur
100	50	ZMO 61 1100	ZME 20 0031
110	50	ZMO 61 1110	ZME 20 0032
220	50	ZMO 61 1220	ZME 20 0033
230	50	ZMO 61 1230	ZME 20 0033
240	50	ZMO 61 1240	ZME 20 0033
250	50	ZMO 61 1250	ZME 20 0034
100	60	ZMO 62 1100	ZME 20 0031
115	60	ZMO 62 1115	ZME 20 0035
220	60	ZMO 62 1220	ZME 20 0033



Pos.	Ref. No.	DIN	Benennung	Description	Désignation
	701 O.C		<b>Supportschleifmaschine</b>	<b>Toolpost grinder</b>	<b>Rectifieuse adptable</b>
1	SOC 000 010		Körper	Main base	Embase
2	SOD 000 020		Schleifspindel	Grinding spindle	Broche
3	SOD 000 030		Lagerflansch	Flange	Flasque
4	SOD 000 040		Gewinding	Threaded collar	Bague filetée
5	SOD 000 050		Schleifdorn	Grinding arbour	Broche
6	SOD 000 060		Klemmschraube	Tensioning screw	Vis de serrage
7	SOD 000 070		Schlitzmutter	Nut	Ecrou
8	SOD 000 080		Scheibenschutz	Wheel guard	Protecteur de meule
9	SOD 000 090		Riemenscheibe	Pulley	Poulie
10	SOD 000 100		Spannscheibe	Tensioning washer	Rondelle de serrage
11	SOD 000 110		Motorriemenscheibe	Motor pulley	Poulie du moteur
12	SOD 000 120		Riemenschutz	Belt guard	Protecteur de courroie
13	SOD 000 130		Distanzscheibe	Compensating washer	Rondelle d'ecartement
14	SOD 000 140		Hülse	Spacer	Douille
15	SOC 000 160		Drehzahlschild	Rating plate	Plaquette de vitesses
16	SOD 020 000		Trägerplatte	Carrier plate	Plaque
17	ZFD 93 1500	15x8,2x0,8 DIN 2093	Tellerfeder	Disc spring	Ressort belleville
18	ZSB 22 0530	B5,3 DIN 2091	Scheibe	Washer	Rondelle
19	ZSR 33 0516	M5x16 DIN 933-5.6	Sechskantschraube	Hexagon head screw	Vis hexagonale
20	ZSR 12 0516	M5x16 DIN 912-6.9	Zylinderschraube	Socket head screw	Vis 6 pans creux
21	ZSB 21 0430	A4,3 DIN 9021	Scheibe	Washer	Rondelle
22	ZGF 36 2506	25xM6 DIN 6336	Sterngriff	Star handle	Poigné - étoile
23	ZRM 05 0406	406 x 5 x 3	Keilriemen	V-belt	Courroie-V
24	ZSR 33 0512	M5x12 DIN 933-5.6	Sechskantschraube	Hexagon head screw	Vis hexagonale
25	ZSB 25 0530	B5,3 DIN 125	Scheibe	Washer	Rondelle
26	ZSR 84 0410	M4x10 DIN 84-4.8	Zylinderschraube	Flat head screw	Vis à tête cylindrique
27	ZSB 21 0840	A 8,4 DIN 9021	Scheibe	Washer	Rondelle
28	ZSR 84 0416	M4x16 DIN 84-4.8	Zylinderschraube	Flat head screw	Vis à tête cylindrique
29	ZSR 12 0416	M4x16 DIN 912-6.9	Zylinderschraube	Socket head screw	Vis 6 pans creux
30	ZFD 85 3316	A3x3x16 DIN 6885	Paßfeder	Parallel key	Clavette parallele
31	ZLG 62 0206		Rillenkugellager	Ball bearing	Roulement à billes
32	ZFD 94 3461	34,6x20,4x0,4	Tellerfeder	Disc spring	Ressort belleville
33	ZNA 76 0144	1,4x4 DIN 1476-4.6	Kernnagel	Rivet	Rivet de fixation
34	SOD 000 150		Schleifdorn	Grinding arbour	Broche de réctification
35	SOD 000 170		Stiftschraube	Stud	Goujon
36	SOD 000 180		Schlitzmutterndreher	Special wrench	Clé spéciale
37	ZSR 84 0308	M3x8 DIN 84-4.8	Zylinderschraube	Flat head screw	Vis à tête cylindrique
38	ZSB 25 0320	A3,2 DIN 125	Scheibe	Washer	Rondelle
39	ZST 13 1010	M10x10 DIN 913-45H	Abdrückschraube	Forcing screw	Vis de dégagement
40	ZWZ 95 0810	8x10 DIN 895	Doppelmaulschlüssel	Open-ended spanner	Clé plate simple
41	SOD 000 190	SW19 DIN 894	Einmaulschlüssel	Single-ended spanner	Clé de service
42	ZWZ 11 0500	SW5 DIN 911	Sechskantschraubendreh.	Hexagonal key	Clé à six pans
43			Schleifscheibe	Grinding wheel	Meule
			<b>E-Ausrüstung</b>	<b>Electrical equipment</b>	<b>Electrique equipment</b>
44	ZPG 10 0008	MZB 13	Kabelverschraubung	Screw-type conduit fitting	Raccordement à vis
45	ZME 20 0030		Schalter mit Gehäuse	Switch with housing	Interrupteur avec corps
46	ZMO ... .. *		Motor	Motor	Moteur
47	ZKO ... .. *		Kondensator	Condenser	Condensateur
48	ZME 20 0036		Lüfterhaube	Fan cover	Carter de ventilateur

Ref. Nr. siehe Tabelle

Ref. Nr. see table

Ref. Nr. voir tableau

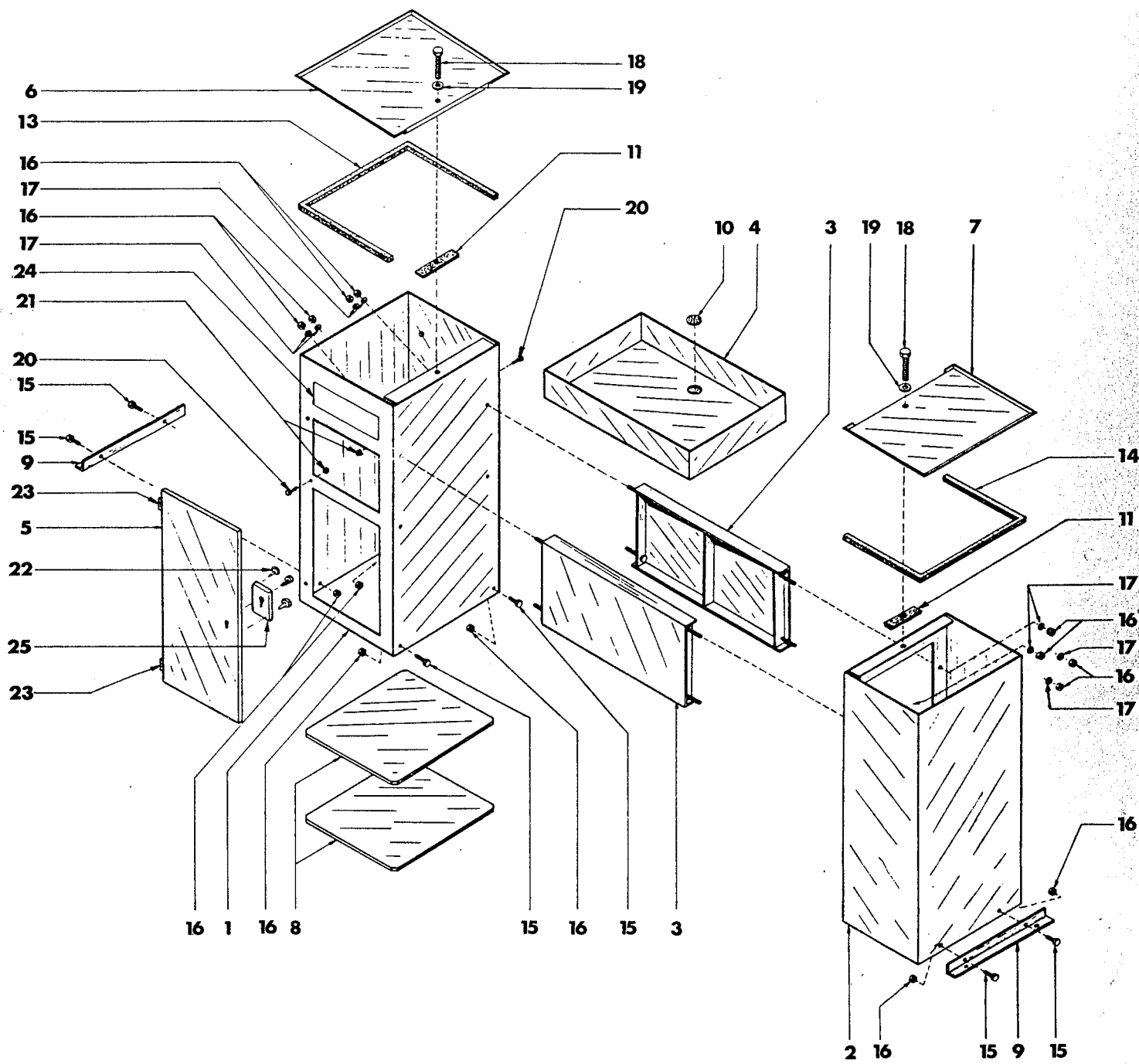

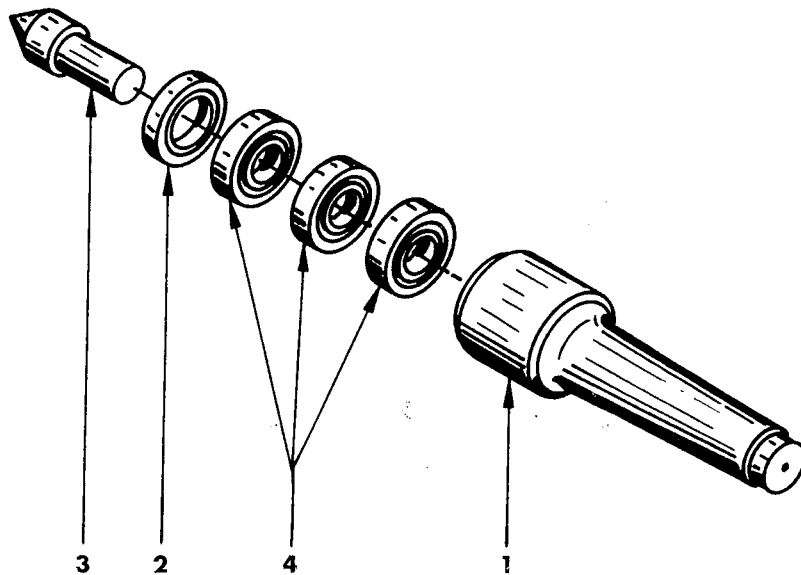

Pos	Ref.No.	DIN	BENENNUNG	DESCRIPTION	DESIGNATION
	<b>732 000</b>		<b>G. Rollkörner</b>	<b>Revolving center</b>	<b>Pointe tournante</b>
1	B2Z 260 010		Körper	Tapered shank	Corps
2	B2Z 260 020		Abdeckring	Cover	Bague de fermeture
3	B2Z 260 030		Körner	Center	Pointe
4	ZLG 06 0800	608 EL8	Rillenkugellager	Ball bearing	Roulements à billes

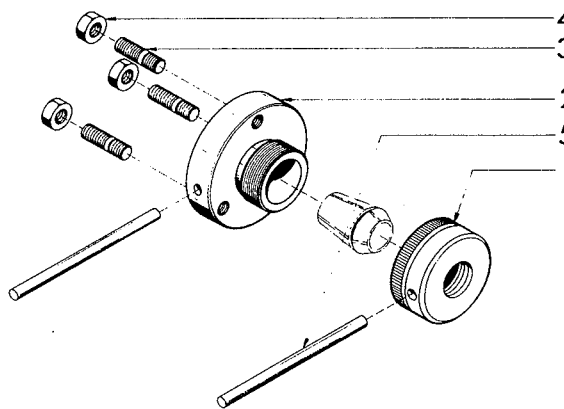

Pos.	Ref. No.	DIN	Benennung	Description	Designation
	<u>700 060</u>		<u>Gr. Spannzangenhalter für Spannzangen ESX 25</u>	<u>Collet attachment compl. for collets ESX 25</u>	<u>Ens. porte-pince pour pinces ESX 25</u>
1	A5Z o4o o2o		Spannmutter	Locking ring	Ecrou de serrage
2	B1Z o61 o1o		Zangenhalter	Collet holder	Porte-pince
3	ZSR 39 o82o	M8x2o DIN 939-5.9	Stiftschraube	Stud	Goujon
4	ZMU 34 o8oo	M8 DIN 934-6	Sechskantmutter	Hexagon nut	Ecrou 6 pans
5	ZST 11 o71o	6h11 x 1oo DIN 7	Zylinderstift	Dowel pin	Tige de serrage

Pos.	Ref.No.	DIN	Benennung	Description	Designation
1-25	750 000		Maschinenuntersatz	Machine base	Socle machine
1	B2Z 361 000		Linker Ständerfuß	Table leg left	Fût de gauche
2	B2Z 362 000		Rechter Ständerfuß	Table leg right	Fût de droite
3	B2Z 364 000		Mittelteil	Mid-section	Panneau de jonction
4	B2Z 366 000		Spanwanne	Chip tray	Bac à copeaux
5	B2Z 363 000		Türe	Door	Porte
6	B2Z 360 030		Linke Tasse	Holder left	Plateau de gauche
7	B2Z 360 040		Rechte Tasse	Holder right	Plateau de droite
8	B2Z 360 070		Einlageplatte	Insert	Etagères
9	C4Z 220 110		Winkel	Angle plate	Cornières
10	C4Z 220 150		Abflußgitter	Sink grid	Crépine
11	C4Z 220 090		Gummieinlage	Rubber packing	Insert en caoutchouc
13	B2Z 360 050		Moosgummi	Sectional strandrubber	Bande de caoutchouc mousse
14	B2Z 360 060		Moosgummi	Sectional strandrubber	Bande de caoutchouc mousse
15	ZSR 33 0812	M8x12 DIN933	Sechskantschraube	Hexagon head screw	Vis tête hexagonale
16	ZMU 34 0800	M8 DIN934	Mutter	Hexagon nut	Ecrou hexagonal
17	ZRG 27 0080	A8 DIN127	Federring	Spring washer	Rondelle grower
18	ZSR 33 1035	M10x35 DIN933	Sechskantschraube	Hexagon head screw	Vis tête hexagonale
19	ZSB 25 1050	B10,5 DIN125	Scheibe	Washer	Rondelle plate
20	ZSR 33 0508	M5x8 DIN933	Sechskantschraube	Hexagon head screw	Vis tête hexagonale
21	ZMU 34 0500	M5 DIN934	Mutter	Hexagon nut	Ecrou hexagonal
22	ZSR D1 2916	B2,9 DIN7972	Blechschaube	Sheet metal screw	Vis à tôle
23	ZXM 300 055		Scharnier	Hinge	Charnière
24	C4Z 220 180		EMCO Folie	EMCO foil	EMCO feuille
25	ZXM 022 000		Anschlagschloß	Lock	Serrure