

# B SOFTWARE DESCRIPTION

## 1. VOCABULARY EXPLANATIONS

bit (b)	Binary sign = smallest memory unit of the computer (e.g., current - not current or magnetic - not magnetic)
Byte (B)	Memory unit to store a letter, a number or a sign (1 byte = 8 bit) <u>Kilobyte (K, kB):</u> usual unit (measurement) for the memory capacity of a computer (1 kilobyte = $2^{10}$ bytes = 1024 bytes) <u>Megabyte (MB):</u> 1 megabyte = 1024 kilobytes
CAD	<u>Computer Aided Design</u> = tool construction (see chapter 4.2)
CAM	<u>Computer Aided Manufacturing</u> = determining the machining cycle (see chapter 4.3)
CNC	<u>Computer Numerical Control</u>
Coprocessor	Additional arithmetic unit as a support for the microprocessor
Disk	Exchangable, magnetic plastic disk, to store software (memory capacity, e.g., 5½ inches disk with 360 + kB or 1.2 MB or 3½ inches disk with 720 kB or 1.44 MB)
Hard disk	Magnetized disks permanently located in the computer, to store software (memory capacity for PC, e.g., up to 80 MB)
Graphics card	Shapes the computer signals for the screen
Hardware	Are all usable objects
Compatibility	Two devices are compatible, if they can operate with each other without any additional equipment or can be exchanged for each other
Menu	List of the possibilities offered
Microprocessor	Central arithmetic unit of the PC
NC program	List of all information, which a machine tool needs to manufacture a work piece
PC	<u>Personal Computer</u> = multi-purpose, small computer for one person
Postprocessor	Converts a program into information, which the CNC machine tool understands and receives
RAM	<u>Random Access Memory</u> = operational memory = component, which loses information, when the device is switched off (memory capacity of the RAM usually amounts to 640 + kB for PC)
Interface	Connection element for connecting external devices to the PC <u>Serial interface:</u> processes 1 bit <u>Parallel interface:</u> processes 1 byte (= 10-fold information flow speed)
Software	The software is a thought-defined product (e.g., a program on a disk), which controls the computer. <u>System software:</u> basic, administrative program; contains the operating system (e.g., DOS = <u>Disk Operating System</u> ) and facilitates the running of the application software <u>Application software:</u> special operational program (e.g., Unimat PC software). The hardware can carry out the tasks given by this program.

## 2. SOFTWARE INSTALLATION , ACCESS INTO PROGRAM

### 2.1 Possible PC configuration

In order to operate with this EMCO software, you require a PC with the following capabilities:

- IBM compatible (PC, PC/XT, PC/AT, PC/AT-386)
- Operating system MS-DOS from version 3.1
- 640 kB RAM (main memory)
- 1 Hercules graphics card with a parallel interface (Centronics) or 1+ EGA colour graphics card
- Monochrome screen or EGA colour screen capable of graphics
- 2 disk drives or 1 disk drive + 1 hard disk with 20 MB
- 1 parallel interface for the use of an EGA colour graphics card (for the connection of a printer = option)

An arithmetic coprocessor is not absolutely necessary for the operation with this EMCO software.

This coprocessor is, above all, recommended for PCs with a slow processing speed (e.g.: PC/XT with a cycle frequency of 4.77 or 8 MHz), however, since it executes the arithmetic operations much faster.

The use of a coprocessor is not required for PCs with a cycle frequency of over 10 MHz (PC/AT).

Example: IBM compatible PC/AT with

- 640 kB RAM
- 1 disk drive 1.2 MB
- 1 hard disk 44 MB
- 1 EGA graphics card
- EGA screen capable of graphics
- keyboard
- operating system MS-DOS version 3.3
- 1 parallel interface

#### Compatibility problems

The software runs on all 100 % IBM compatible PCs. Upon request, EMCO informs you of all those processors, on which this EMCO software was tested.

### 2.2 PC with hard disk and 1 disk drive

#### Installation

Start DOS (Disk Operating System). If necessary, consult the DOS manual, which was supplied with your computer.

The files INT10.COM and HGC.COM or HGC.EXE must be available on your hard disk (in the main index) and be called up when using a Hercules graphics card in order to initialize this card. These files may not be supplied by us due to copyright laws. If you install this EMCO software on a PC with a Hercules graphics card, the recall of these files is automatically written into the file AUTOEXEC.BAT during the installation of the software.

When the DOS prompt "C: \ >" appears, insert the installation disk 1 into the drive A.

Enter the following command:

Screen display	Entry	Explanation
C: \ >	A : ↵	Change to drive A
A: \ >	I ↵	Call up installation program

After entering the command "I" and pressing the ENTER key, the registration screen for setting the language appears.

Control menu:

```

emco
COMPACT 5-PC INSTALLATION 1.0

CONFIGURE      IBM GRAPHIC
UNIT           METRIC
PATH           C:\COMPACT\

Are specifications correct ?
YES            NO
    
```

The previous specifications are displayed:

- YES ... The previous specifications are correct, the software is installed.
- NO ... The previous specifications are incorrect, the installation begins again with "Entering the type of PC".

Select the desired menu point with the arrow keys and confirm it.

If the menu point YES was selected and confirmed, the following appears on the screen:

```

emco
COMPACT 5-PC INSTALLATION 1.0

The COMPACT 5 PC SOFTWARE is
compiled and copied into
the given path ...

Please wait !

Copying ...

C:\COMPACT\
    
```

The individual files are copied from the drive A into the sub-directory determined by you.

The following message appears after a short time:

```

Disk 2 in drive A:  insert
    
```

Remove the installation disk 1 from the drive A and insert the installation disk 2 and confirm it.

The following appears:

```

Copying ... 5-10 minutes
    
```

If the software was installed correctly in the PC, the following appears:

```

emco

Installation is finished
    
```

The PC registers with drive A.

Changing the drive:

Screen display	Entry
A: \>	C : ←
C: \>	

The software can be called up (see next page).

## Access

After the DOS prompt "C: \>" appears, enter the following commands:

Screen display	Entry
C: \>	C D [ ] C O M P A C T [ ]
C: \COMPACT>	

\* Space bar

In this way, you change to the sub-directory COMPACT.

### Calling up the program:

If you have altered the program path (=sub-directory) during the installation of the software, you must enter your selected sub-directory name (here COMPACT).

Screen display	Entry
C: \COMPACT>	C O M P A C T [ ]

The title screen appears:

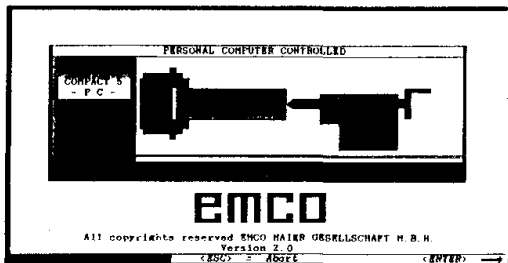

Pressing ENTER:

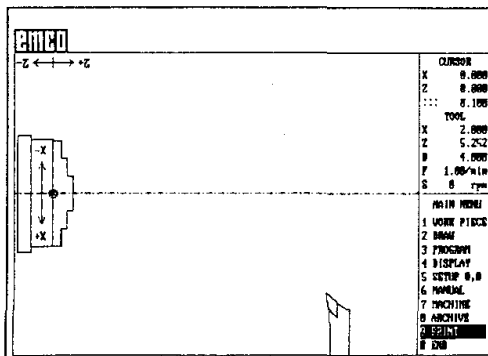

You are now in the program.

### 3. EXPLANATIONS FOR THE SOFTWARE

#### 3.1 The differences in the input keyboards

Small PC keyboard

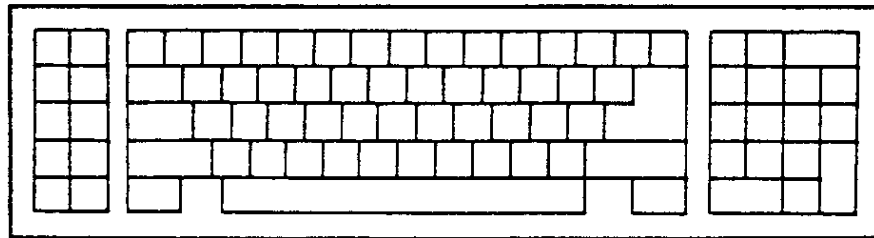

Large PC keyboard

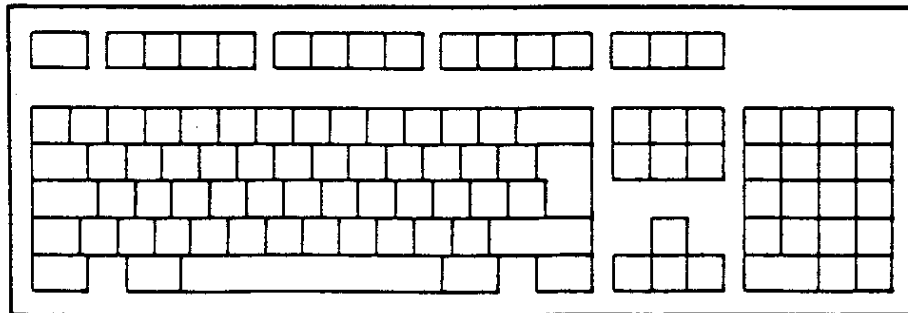

The same key functions are arranged and designated differently on these two types of keyboard.

**Differences in the key designation**

Small PC keyboard	Large PC keyboard

**Note**  
The keys of the large PC keyboard are used in these instructions.

**Preceding zeros**

**Following zeros**

Zeros before a number and after the comma can but do not need to be entered.

**Plus/minus sign**

Plus signs (+) are not entered. The minus sign (-) must be entered before the number.

**Entering large, small letters**

Letters can be entered as large or small letters.

**Enter key**



Inputs are confirmed or stored with the "ENTER" key.

**Decimal point**



The decimal point is entered with this key.

**Separating two entries**



Two subsequent entries are separated with the comma key.

**Example**

For a work piece compilation, the PC requests:

Diameter, work piece length?

Input: 23.5, 46

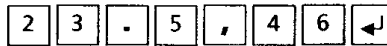

**Error correction**

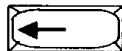

The entry can be corrected with this key. The previously entered character is deleted.

**Interrupting selected commands**



The selected command is interrupted with this key. The previously selected menu level can also be returned to with the Esc. key.

## 3.2 Important key functions

**SHIFT key**

If the SHIFT key is pressed at the same time as the desired key, the upper case of the respective key is selected.

**Example**



If the SHIFT key is not active, the lower case (+) is selected.

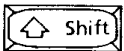

If the SHIFT key is pressed, the upper case (\*) is selected.

**Note**

Only the selected key case is shown in these instructions for easier reading.

### 3.3 Coordinate system

The piece of information "Move the longitudinal slide towards the head stock" is a long piece of information; it would also be different in every language. Thus, the directions of movement for NC machines are described in a coordinate system.

#### Coordinate system of the machine

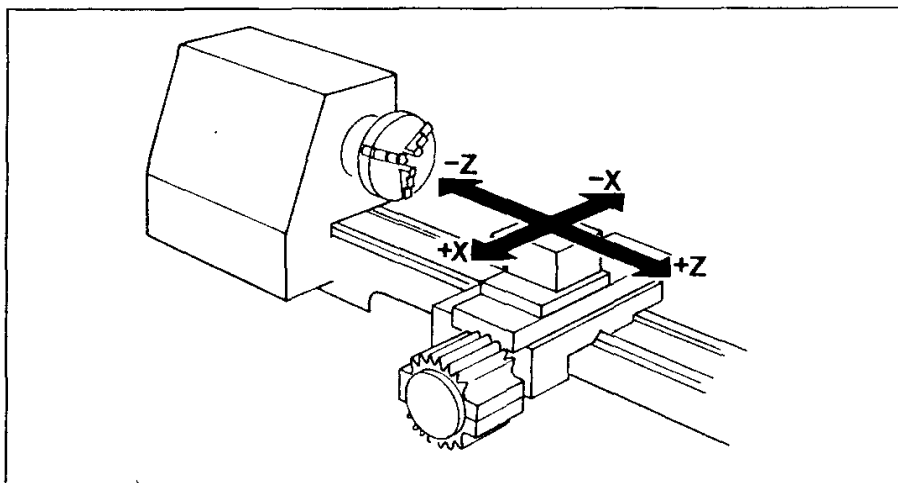

**Z axis** = Axis parallel to the rotary axis

**X axis** = Axis perpendicular to the rotary axis

**- Z movement** = Movement of the longitudinal slide towards the head stock

**+ Z movement** = Movement of the longitudinal slide away from the head stock

**+ X movement** = Movement of the cross slide away from the rotary axis

**- X movement** = Movement of the cross slide towards the rotary axis

#### Representing the coordinate system on the screen

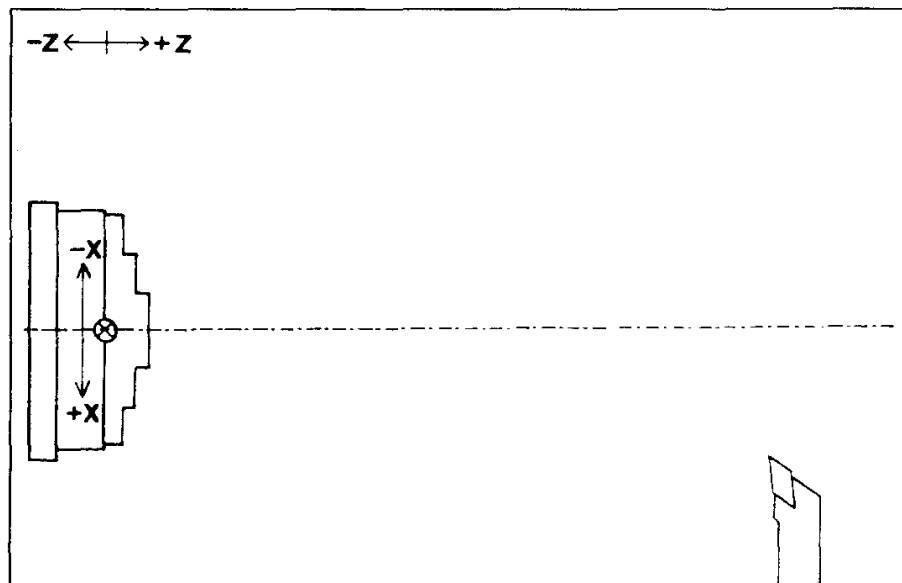

### 3.4 Screen cursor

A cursor (graticule) is shown on the screen. This cursor can be moved on the screen.

#### Moving the screen cursor

The cursor is moved on the screen by means of the 4 arrow keys.

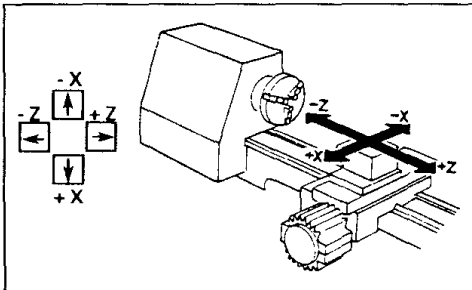

#### Further key functions



Doubling the step size of the cursor



Halving the step size of the cursor



The cursor jumps to the middle of the screen





The cursor jumps to the reference point

Step size .... distance of movement each time the key is pressed

#### Showing the screen cursor

There are two ways of showing the cursor on the screen:

1.  Cursor as a graticule  
Normal representation of the cursor
2.  Reduced cursor  
A reduced cursor is shown, when the key "<" is pressed.

The cursor is shown as a graticule again, when the key ">" is pressed.

#### Cursor programming methods

You can describe the path of the screen cursor in the program: there are generally two ways of describing this path.

#### Absolute value programming (reference value programming)

The points, to which the screen cursor is to proceed, are given starting from a zero point (reference point R).

#### Example

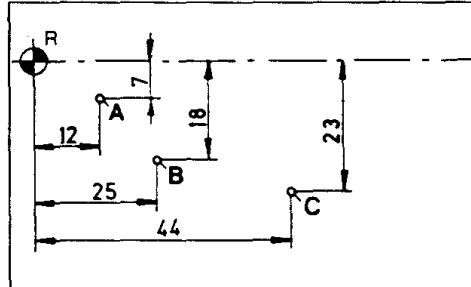

#### Incremental value programming

Chain dimensions are entered for the incremental value programming. The correct position of the screen cursor is the starting point for every path description.

#### Example

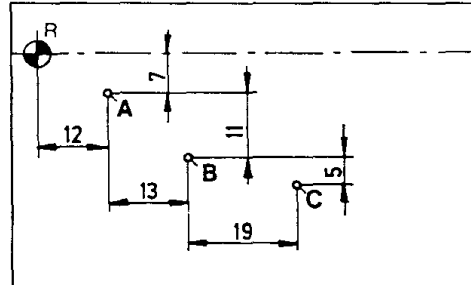



### 3.5 Menu structure

This EMCO software is divided into menus (= selection possibilities). Divisions into main menu, menus and submenus are used depending on the hierarchy. Jumps back- and forwards between these individual menus can be made without limitations.

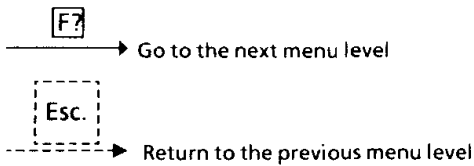
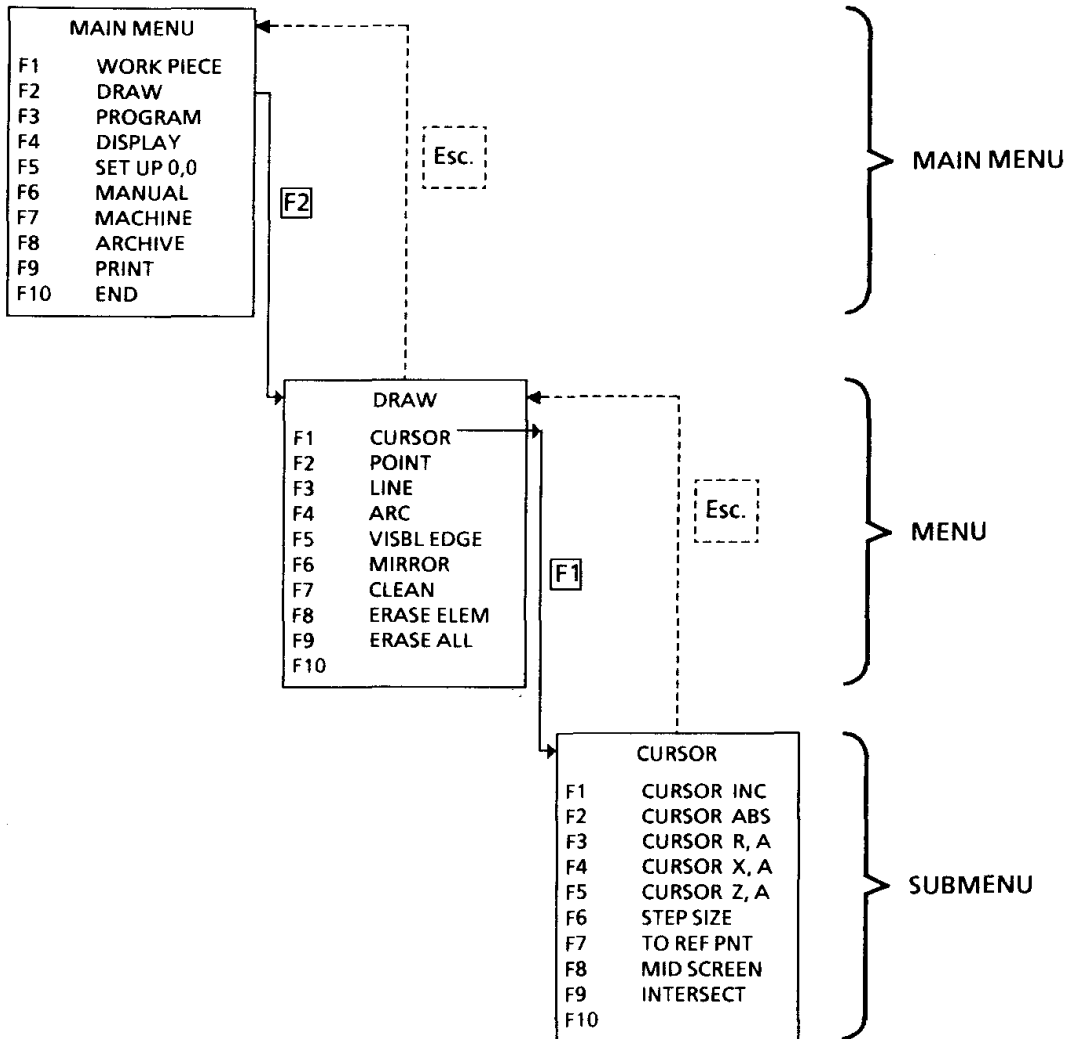



# Menu summary

## Notes

You can select and activate the individual menu points with the function keys F1 to F10 or with the space bar.

A command can be interrupted or a return to the previous menu level activated with the key Esc.

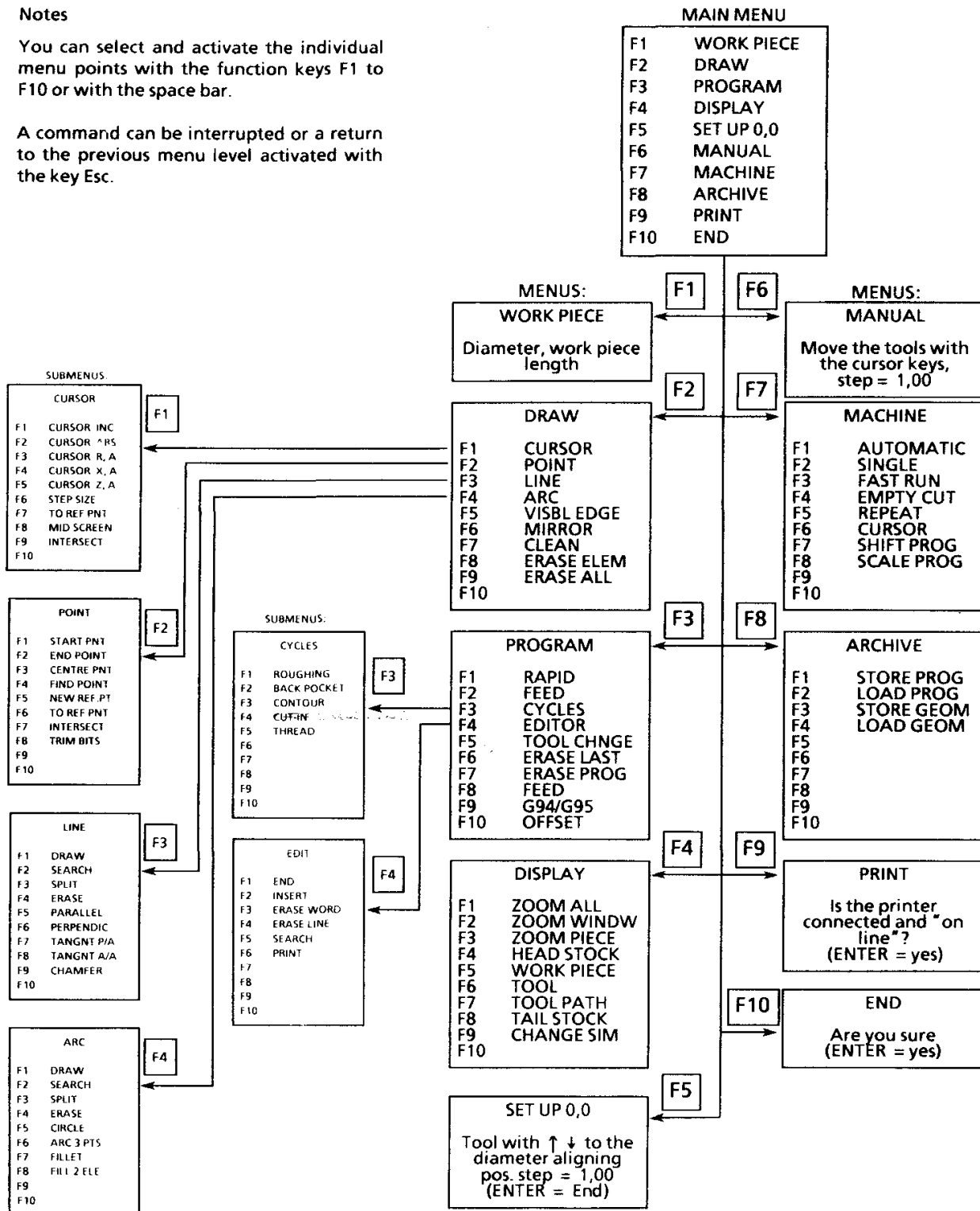



### 3.6 Screen display

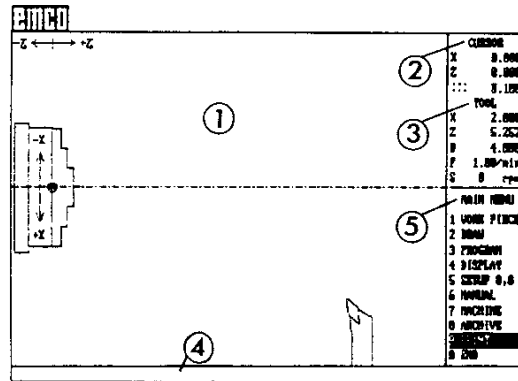

- 1 Diagrammatic representation of the working area
- 2 Displaying the cursor position [mm]  
X, Z ... Position of the cursor  
::: ... Step size of the cursor (distance travelled every time a key is pressed)
- 3 Displaying the tool position  
X, Z ... Position of the tool [mm]  
D ... Diameter position of the tool [mm]  
F ... Feed speed [mm/min]  
S ... Main spindle speed [rpm]
- 4 Displaying the screen messages
- 5 Menu display

### 3.7 Selection / deselection of the menu points

There are two possibilities:

Possibility 1

By means of the space bar and

Example

Activating the PROGRAM menu

	Go to the desired menu point with the space bar
	Confirm entry and activate PROGRAM menu
	Return to the main menu

Possibility 2

By means of the function keys F1 to F10

Example

Activating the PROGRAM menu

	Selection and activation of the PROGRAM menu
	Return to the main menu

PROGRAM	
F1	RAPID
F2	FEED
F3	CYCLES
F4	EDITOR
F5	TOOL CHNGE
F6	ERASE LAST
F7	ERASE PROG
F8	ERASE

**Note**

The activation of the individual

## 4. MENU POINTS

<b>4.1</b>	<b>Work piece</b>	<b>54</b>
<b>4.2</b>	<b>Draw</b>	<b>55</b>
4.2.1	Cursor	56
4.2.2	Point	59
4.2.3	Line	61
4.2.4	Arc	64
4.2.5	Visible edges	68
4.2.6	Mirroring	68
4.2.7	Cleaning	68
4.2.8	Erasing the geometric element	69
4.2.9	Erasing all	69
4.2.10	Hotkeys - draw	70
	Specimen example 1	71
	Specimen example 2	72
	Specimen example 3	73
<b>4.3</b>	<b>Program</b>	<b>74</b>
4.3.1	Moving in the rapid	74
4.3.2	Moving with feed speed	74
4.3.3	Cycles	74
	Roughing cycle	75
	Back pocket cycle	77
	Follow contour cycle	79
	Cut-in cycle	81
	Threading cycle	83
4.3.4	Edit (see chapter 6)	90
4.3.5	Tool change	91
4.3.6	Erase the last movement	91
4.3.7	Erasing the machining program	91
4.3.8	Entering the feed values	91
4.3.9	Change feed unit	91
4.3.10	Entering the finishing offsets	91
<b>4.4</b>	<b>Display</b>	<b>92</b>
4.4.1	Zoom all	92
4.4.2	Zoom window	92
4.4.3	Zoom work piece	93
4.4.4	Removing, inserting the head stock	93
4.4.5	Removing, inserting the work piece	93
4.4.6	Removing, inserting the tool	93
4.4.7	Removing, inserting the tool path	94
4.4.8	Inserting, removing the tail stock	94
4.4.9	Changing the simulation display	94
4.4.10	Hotkeys - machine	95
<b>4.5</b>	<b>Set up 0,0</b>	<b>96</b>
<b>4.6</b>	<b>Manual</b>	<b>97</b>
<b>4.7</b>	<b>Machine</b>	<b>98</b>
4.7.1	Automatic	98
4.7.2	Single	98
4.7.3	Fast run	98
4.7.4	Empty cut step	98
4.7.5	Repeating the program	99
4.7.6	Moving the tool to the cursor	99
4.7.7	Shifting the program	99
4.7.8	Altering the scale program	99
<b>4.8</b>	<b>Archive</b>	
4.8.1	Storing the program	100
4.8.2	Loading the program	100
4.8.3	Storing the geometry	101
4.8.4	Loading the geometry	101
<b>4.9</b>	<b>Print</b>	<b>101</b>
<b>4.10</b>	<b>End</b>	<b>101</b>



## 4.1 Work piece (F1)

The work piece is defined in this menu, and it is displayed clamped in the chuck.

Unit: [mm]

Example

F1

Screen message

Diameter, work piece length:

22,100

Diameter, length of the drill hole (ENTER = no)

no

yes

4,10

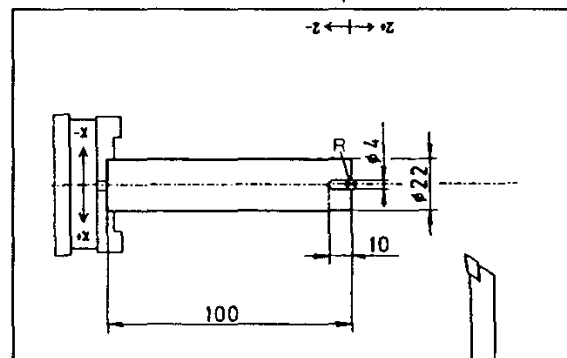
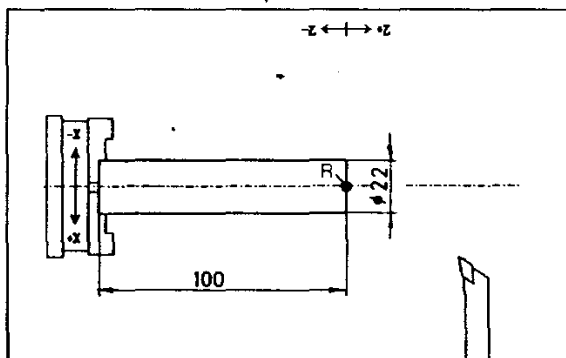

The work piece clamped in the chuck appears on the screen, and the exit from the WORK PIECE menu takes place at the same time.

Note

The reference point = R (point X = 0, Z = 0 of the coordinate system) is situated on the Z axis at the right-hand end of the work piece, when the work piece is called up.





## 4.2 Draw (F2)

The contour of the work piece is determined in this menu.

### Preliminary explanations

You only have to draw the lower half of the work piece contour on the screen, without circumferential edges. Circumferential edges are added after drawing the work piece contour, and by mirroring around the Z + axis, you automatically receive the complete representation of the work piece contour. The compilation of the work piece contour is carried out in the submenus described on the following pages.

### Summary of sub menus

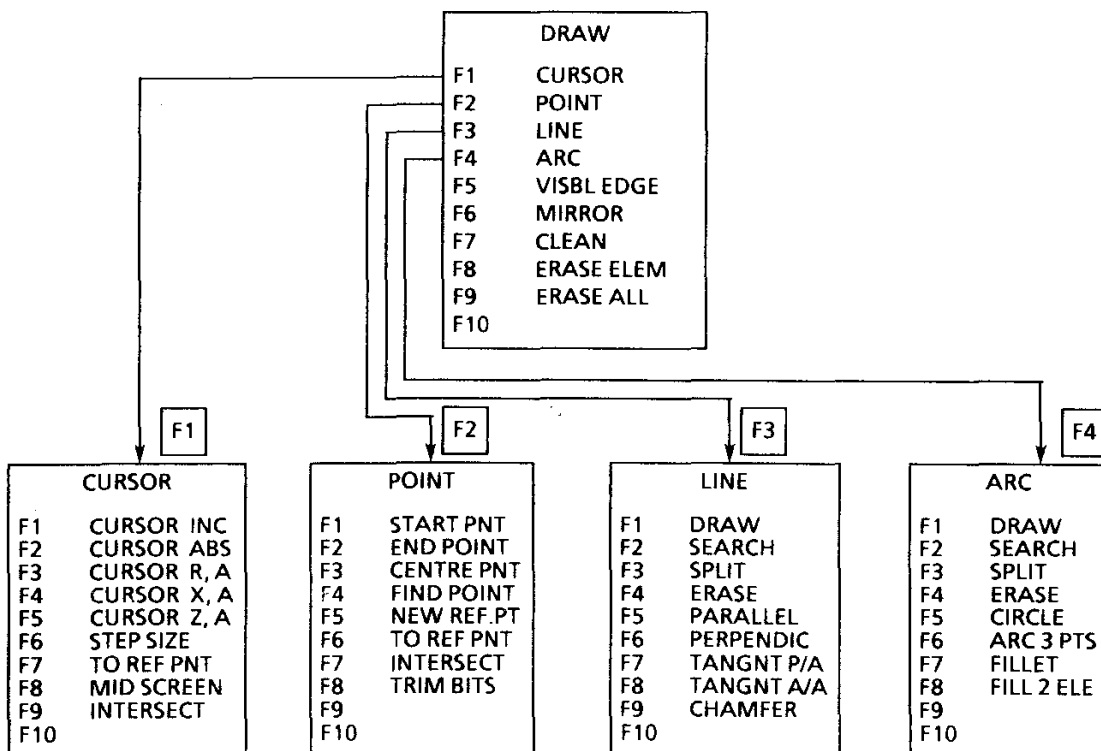



## Description of the individual sub-menus

### 4.2.1 Cursor (F1)

In this submenu, it is determined, how the cursor is to be positioned on the screen.



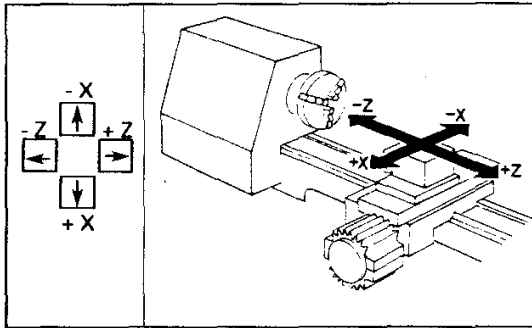

CURSOR	
F1 CURSOR INC	F6 STEP SIZE
F2 CURSOR ABS	F7 TO REF PNT
F3 CURSOR R, A	F8 MID SCREEN
F4 CURSOR X, A	F9 INTERSECT
F5 CURSOR Z, A	F10

#### Moving the screen cursor

The cursor is moved on the screen by means of the 4 arrow keys.





#### Further key functions

-  Doubling the step size of the cursor
-  Halving the step size of the cursor
-  The cursor jumps to the middle of the screen
-  The cursor jumps to the reference point

Step size .... distance of movement each time the key is pressed

#### Showing the screen cursor

There are two ways of showing the cursor on the screen:

1.  Cursor as a graticule  
Normal representation of the cursor
2.  Reduced cursor  
A reduced cursor is shown, when the key "<" is pressed.

The cursor is shown as a graticule again, when the key ">" is pressed.

#### Calculating functions in the CURSOR submenu

For every menu point in the CURSOR submenu, where a number is prompted, there are many calculating functions available to you for the entry of arithmetical functions. In this way, you possess an aid capable of performance, which gives valuable help, especially for coordinate entries and angle calculations.

The following signs or mathematical functions can be used:

Entry	Function
+	Addition
-	Subtraction
*	Multiplication
:	Division
**	To the power of
(	Open bracket
)	Close bracket
SIN	Sin
COS	Cos
TAN	Tan
DSIN	Sin in degrees
DCOS	Cos in degrees
DTAN	Tangent in degrees
ASIN	Arc sin
ACOS	Arc cos
ATAN	Arc tangent
DASIN	Arc sin in degrees
DACOS	Arc cos in degrees
DATAN	Arc tangent in degrees
SQRT	Square root
PI	3.1415927

Any arithmetical function can be entered instead of a simple number for numerical entries (= numbers). The use of brackets is allowed. These can be nested as much as is required.

#### Note



Entered functions must be written in brackets (see example).

#### Example

You are in the CURSOR submenu. An incremental coordinate is to be calculated.

$$X = 10 \frac{\sqrt{3}}{2}, Z = 50$$

Therefore, enter the following:

  $10 * \text{SQRT}(3) : 2, 50$  

A cursor step of 8.66 in X and 50 in Z is the result.

**Positioning the cursor incrementally (F1)**

Unit: [mm]

The cursor is shifted from the present position by the entered values.

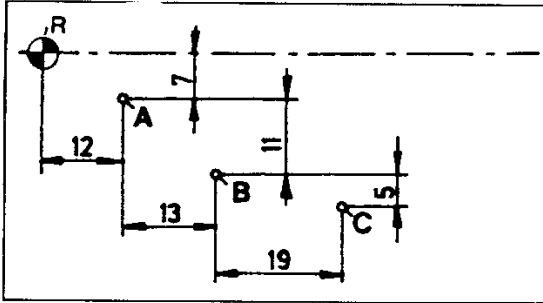

**Positioning the cursor absolutely (F2)**

Unit: [mm]

The cursor is shifted by the values entered (always measured from the reference point).

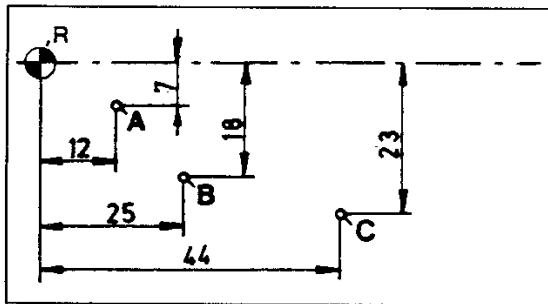

**Positioning the cursor with the radius and angle (F3)**

Unit: [mm], [°]

The cursor is shifted from the present position by the radius and angle entered.

Example: R = 24 mm, A = -30° (clockwise)

Screen message	Entry
	<b>F3</b>
Radius, angle movement from the cursor?	24, -30 <input type="text"/>

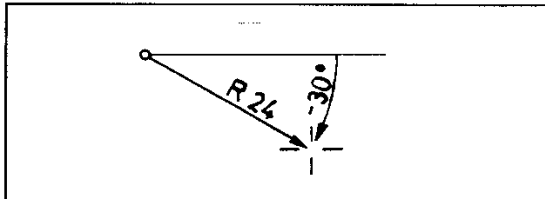

Note: Angle entry

Positive (+) sign = angle in the anti-clockwise direction.

Negative (-) sign = angle in the clockwise direction.

**Positioning the cursor with X dimension and angle (F4)**

Unit: [mm], [°]

Entering the X dimension incrementally

Example: X = 19 mm, A = -45°

Screen message	Entry
	<b>F4</b>
X, angle movement from the cursor?	19, -45 <input type="text"/>

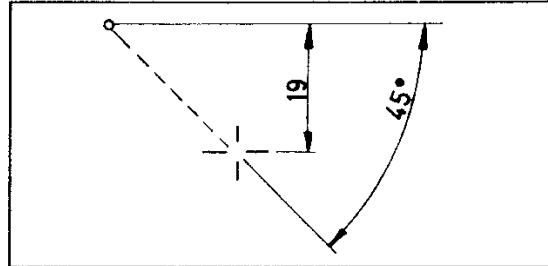

**Positioning the cursor with Z dimension and angle (F5)**

Unit: [mm], [°]

Entering the Z dimension incrementally

Example: Z = 15 mm, A = -35° (clockwise)

Screen message	Entry
	<b>F5</b>
Z, angle movement from the cursor?	15, -35 <input type="text"/>

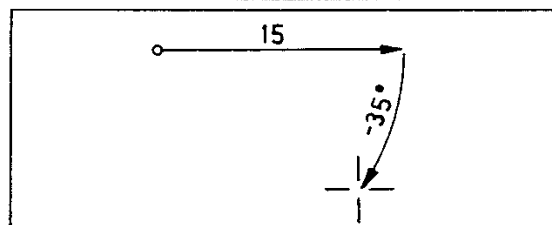

**Determining the step size of the cursor (F6)**

Unit: [mm]

The step size is the distance the cursor moves every time a key is pressed.

The step size of the cursor is 1 mm when you call up the software.

Example: Cursor step should amount to 2.5 mm

Screen message	Entry
	<b>F6</b>
Cursor step 1.000 New step (ENTER = no change)	2,5 <input type="text"/>

Cursor to the reference point (F7)

The reference point is the origin of the coordinate system shown on the screen (reference point = position  $X = 0 / Z = 0$  of the coordinate system).

Position of the reference point

No work piece:

The reference point is situated on the Z axis at the stop of the clamping device.

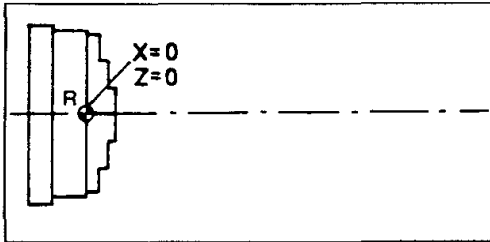
Workpiece compiled:

The reference point is situated on the Z axis at the right-hand edge of the work piece.

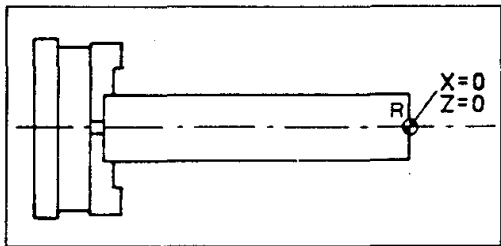

The cursor jumps to the reference point, when the key F7 is pressed.

Find the point of intersection (F9)

Position the cursor by means of the arrow keys near to the point of intersection to be found.

The cursor jumps to the neighbouring point of intersection, when the key F9 is pressed.

Possibilities for the point of intersection

- two lines
- two circles
- a line and a circle

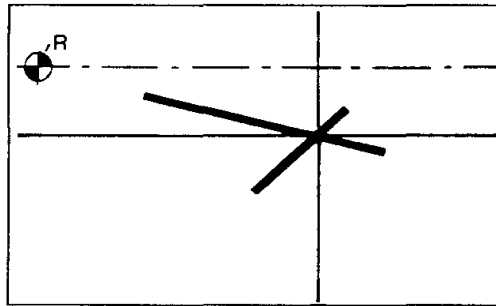
Cursor to the middle of the screen (F8)

The cursor jumps to the middle of the screen, when the key F8 is pressed.

### 4.2.2 Point (F2)

Secondary points for drawing the work piece contour are determined on the screen in this submenu.

The basis of the definition of the geometry (= contour of the work piece) are secondary points.

E.g., a line is defined by a starting point and an end point.

POINT	
F1	START PNT
F2	END POINT
F3	CENTRE PNT
F4	FIND POINT
F5	NEW REF.PT
F6	TO REF.PNT
F7	INTERSECT
F8	TRIM BITS
F9	
F10	

#### Determining the starting point (F1)

The point, on which the cursor is located, is defined as the starting point of an element of geometry (line, circle or arc) by pressing the key F1.

The active starting point is shown on the screen by the symbol ">".

#### Determining the end point (F2)

The point, on which the cursor is located, is defined as the end point of an element of geometry (a line, circle or arc) by pressing the key F2.

The active end point is shown on the screen by the symbol "<".

#### Determining the centre point (F3)

The point, on which the cursor is located, is defined as the centre point of a circle or an arc by pressing the key F3.

The active centre point is shown on the screen by the symbol "o".

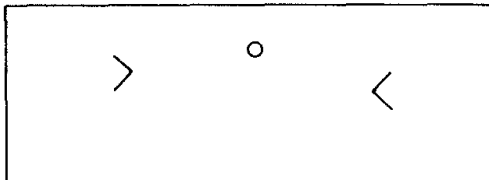

Representation of a starting point, centre point and end point

#### Find point (F4)

Position the cursor by means of the arrow keys near to the point found.

The cursor jumps to the neighbouring point, when the key F4 is pressed.

Purpose:

If machining is to continue from an available point, this must be approached exactly with F4.

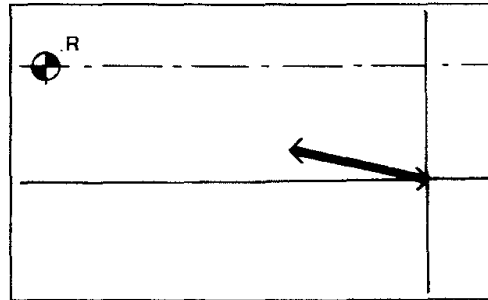

Example:

The cursor is located at the starting point of the line.

#### Re-defining the reference point (F5)

The point, on which the cursor is located, is defined as the new reference point by pressing the key F5.

Reference point (R) = origin of the coordinate system ( $X = 0 / Z = 0$ ).

#### Cursor to the reference point (F6)

The cursor returns to the reference point, when the key F6 is pressed.

#### Find the point of intersection (F7)

Position the cursor by means of the arrow keys near to the point of intersection to be found.

The cursor jumps to the neighbouring point of intersection, when the key F7 is pressed.

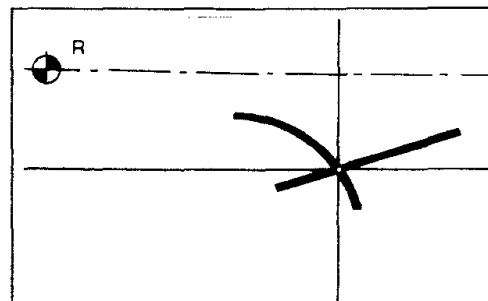

Trim bits (F8)

Trim bits = deleting protruding parts of an element of geometry

Example

Two intersecting lines should result in a bit.

Position the cursor by means of the arrow keys near to the bit to be trimmed.

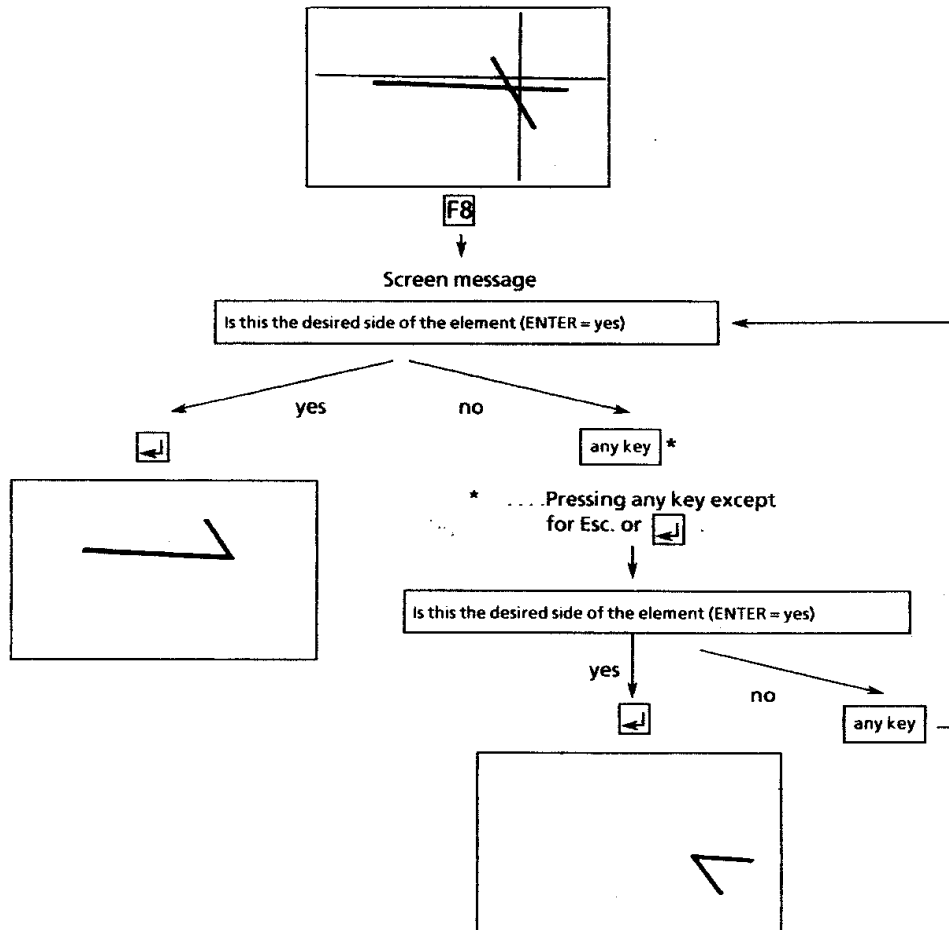





### 4.2.3 Line (F3)

Lines are drawn, altered or erased in this submenu.

LINE	
F1	DRAW
F2	SEARCH
F3	SPLIT
F4	ERASE
F5	PARALLEL
F6	PERPENDIC
F7	TANGNT P/A
F8	TANGNT A/A
F9	CHAMFER
F10	

#### Drawing a line (F1)

A line is drawn, whose starting and end points are already determined.

##### Example

Starting point: X = 35 mm, Z = 65 mm  
 End point: X = 25 mm, Z = 55 mm

A line between the two points is drawn by pressing the key F1.

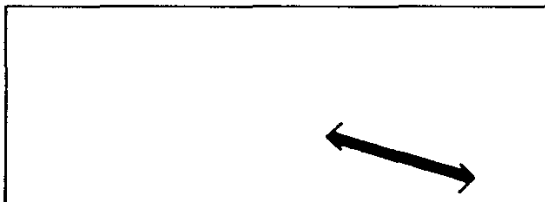

#### Searching for a line (F2)

Position the cursor by means of the arrow keys near to the line to be searched for. The cursor jumps to the neighbouring line, when the key F2 is pressed.

Purpose: If a line is to be machined further, this must first be determined with F2.

#### Splitting a line (F3)

Position the cursor by means of the arrow keys on the splitting point of the line.

This line is divided into two lines, when the key F3 is pressed. (The point of splitting is invisible.)

Purpose: If only a part of a line is to be machined further, this part must be

#### Erasing a line (F4)

Position the cursor by means of the arrow keys near to the line to be erased and press the key F4.

#### Drawing a parallel line (F5)

Unit: [mm]  
 A parallel line is drawn to an existing line (e.g., distance = 5 mm).

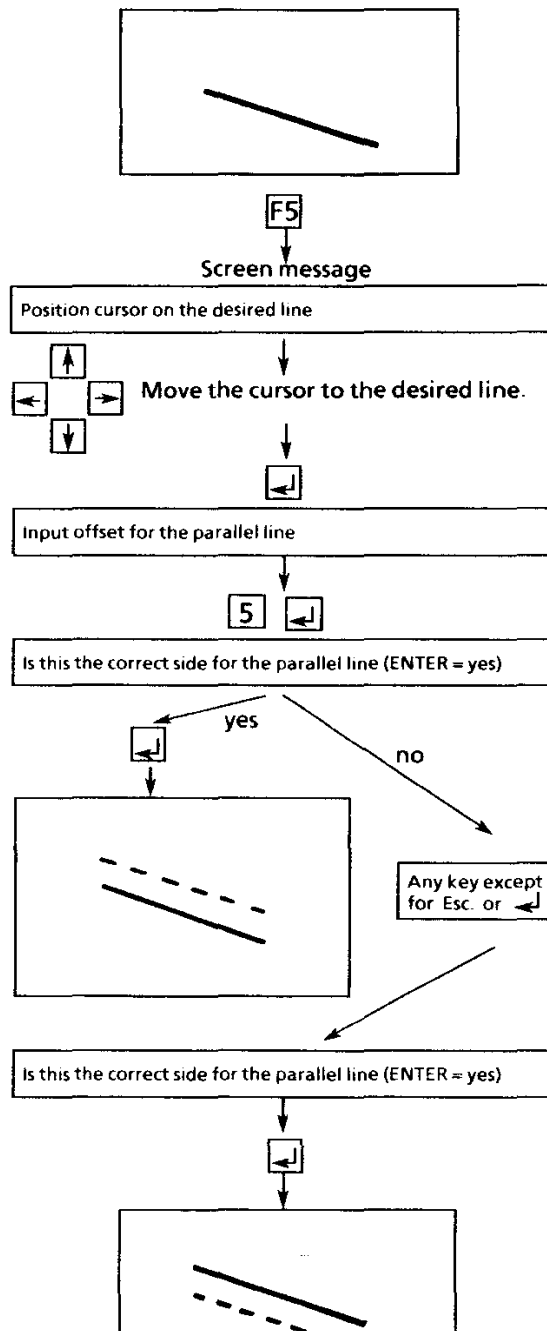



Drawing a perpendicular (90°) to a line (F6)

A perpendicular (90°) is drawn to an existing line.

Move the cursor to the point, where the perpendicular should start.

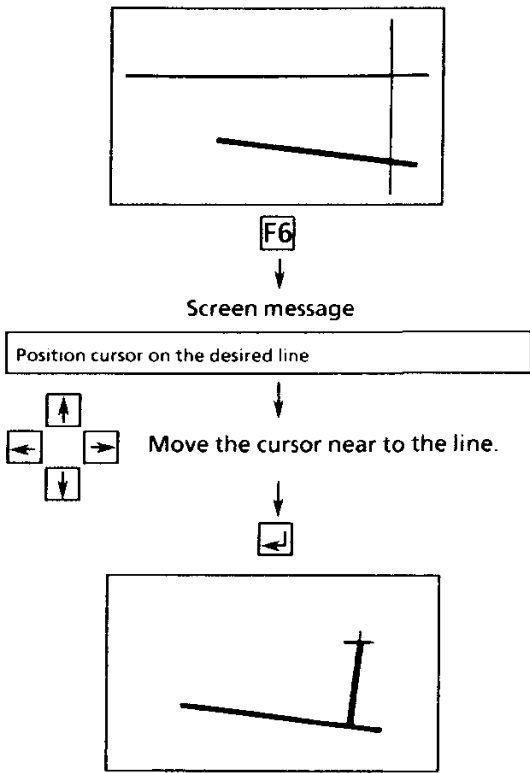

Drawing a tangent point/arc (F7)

A tangent from the current cursor position to an arc is drawn.

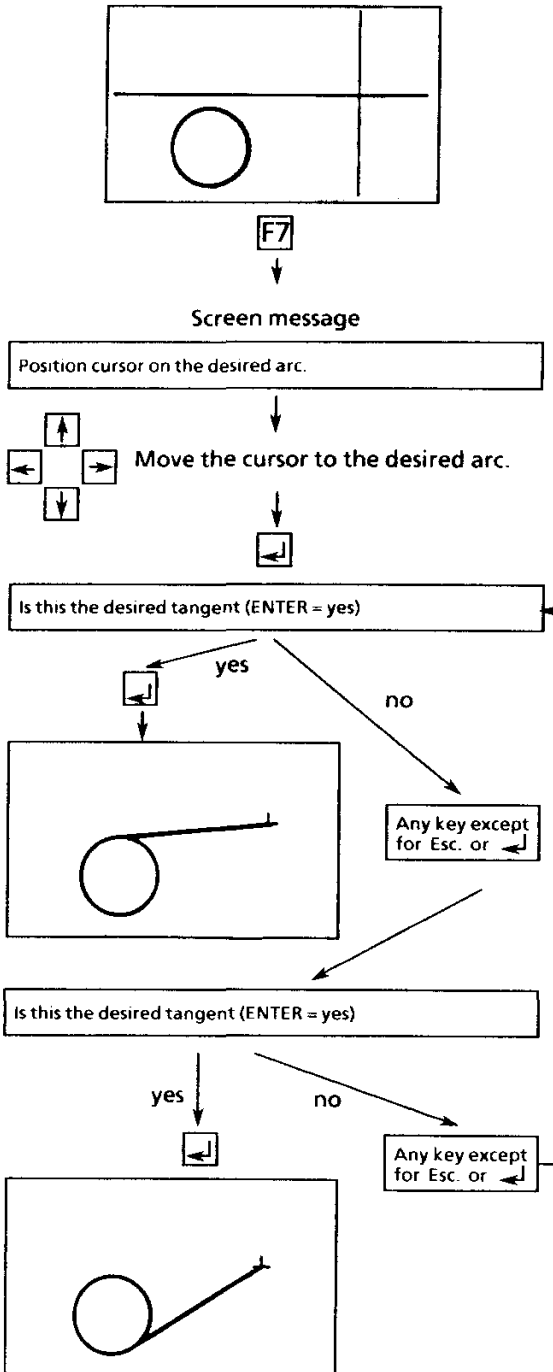



Drawing a tangent arc/arc (F8)

A tangent from an arc to a second arc is drawn.

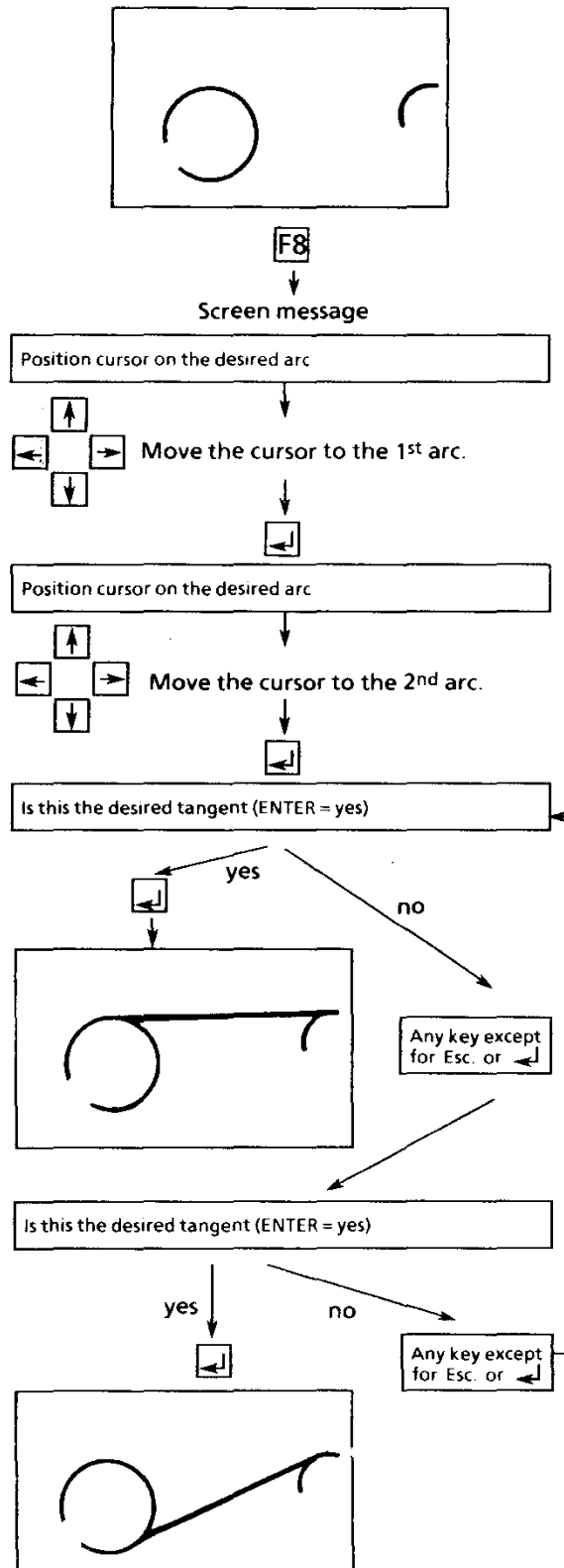

Adding a chamfer (45°) (F9)

Unit: [mm]

Condition:

1. Both lines contact each other at this point (do not intersect).
2. The cursor must be positioned near to this bit.

Example: chamfer = 3 x 3 mm

Screen message	Entry
	<b>F9</b>
Size of the chamfer	3 <input type="text"/>
Is the chamfer correct (ENTER = yes)	<input type="text"/>

Possibilities:

ENTER = Confirming the desired chamfer  
 Any other key = interruption of this command "Adding a chamfer".

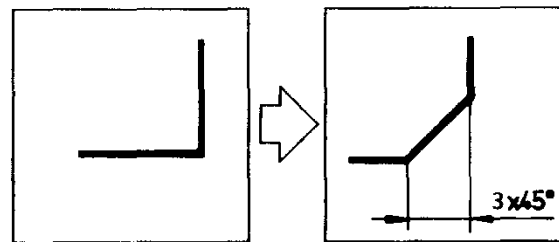

1. Both lines contact each other at this point (do not intersect).  
 2. The cursor must be positioned near to this bit.

### 4.2.4 Arc (F4)

Arcs are drawn, altered or erased in this submenu.

ARC	
F1	DRAW
F2	SEARCH
F3	SPLIT
F4	ERASE
F5	CIRCLE
F6	ARC 3 PTS
F7	FILLET
F8	FILL 2 ELE
F9	
F10	

#### Drawing an arc (F1)

An arc is drawn, whose starting, centre and end points are already determined.

Example:

Starting point: X = 35 mm, Z = 66 mm

Centre point: X = 30 mm, Z = 58 mm

End point: X = 25 mm, Z = 55 mm

An arc (clockwise) is drawn from the starting point to the end point by pressing F1.

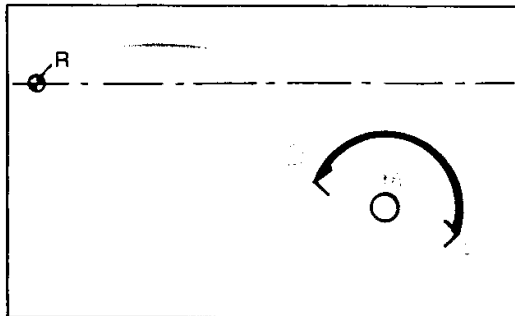

Note:

Arcs are always drawn clockwise.

You can define the position of the arc by the selection of the starting and end points.

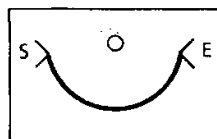
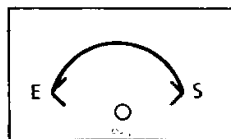

#### Searching for an arc (F2)

Position the cursor by means of the arrow keys near to the arc to be searched for.

The cursor jumps to the neighbouring arc, when the key F2 is pressed.

Purpose

If an arc is machined further, this must be defined with F2 first.

#### Splitting an arc (F3)

Position the cursor by means of the arrow keys on the splitting point of the arc.

The arc is split, when the key F3 is pressed. (The splitting point is not visible.)

Purpose:

If only a part of an arc is to be machined further, this part must first be split from the rest.

Application example:

You must split arcs over 90°, since a starting point of the back pocket must be determined in the program menu (for back pocket).

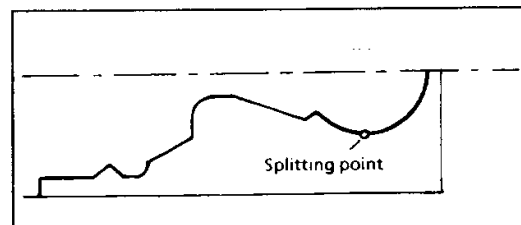

#### Erasing an arc (F4)

Position the cursor by means of the arrow keys near to the arc to be erased and press the key F4.

Attention!

The command "Erase" can no longer be reversed, after it has been carried out!





**Drawing a complete circle (360°) (F5)**

Unit: [mm]

Position the cursor by means of the arrow keys on the centre point of the desired complete circle. Press F5, enter the radius of the circle and confirm it.

Example:

Constructing a complete circle R = 15 mm

Screen message	Entry
	F5
Circle radius 10.000 (ENTER = no change):	15

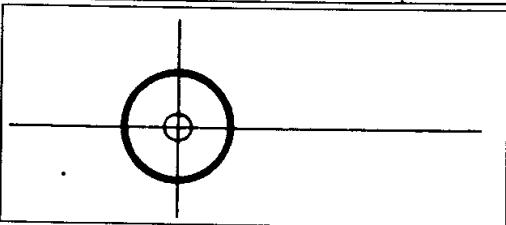

**Adding a fillet (F7)**

Unit: [mm]

- Both lines must contact at this point.
- The cursor must be positioned near to this bit.

Example: Radius = 5 mm

Screen message	Entry
	F7
Radius for the corner?	5
Is the radius correct (ENTER = yes)	

Possibilities:

ENTER = confirming the desired radius  
Any other key = interruption of this command "Adding the fillet".

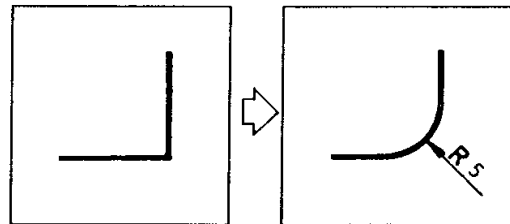

**Drawing an arc with three points (F6)**

Determine the starting point and the end point. Position the cursor on the circumference of the desired arc (= third point). An arc is drawn through the starting, end point and cursor position, when the key F6 is pressed.

Note:

Arcs are always drawn anti-clockwise.

You can define the position of the arc by the selection of the starting and end points.

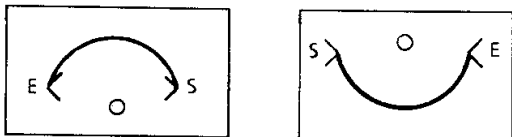

Example:

Starting point: X = 25 mm, Z = 36 mm

End point: X = 16 mm, Z = 25 mm

Cursor position: X = 18 mm, Z = 32 mm

The arc is drawn, when F6 is pressed.

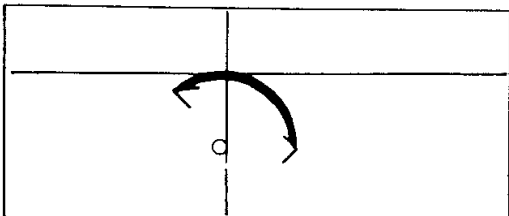

**Fill two elements (F8)**

Geometric elements (points, lines, circles or arcs) are filled tangentially by an arc.

Note:

If you want to fill a circle or an arc, the prompt from the system for the type of filling appears. There are two possibilities.

Filling 1: in front of the circle

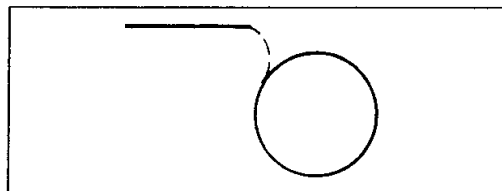

Filling 2: including the circle

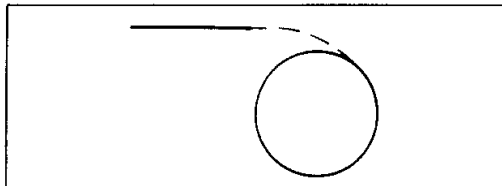

Small radii with small offsets do not work

Example 1

Filling the point of one line with a point of another line.

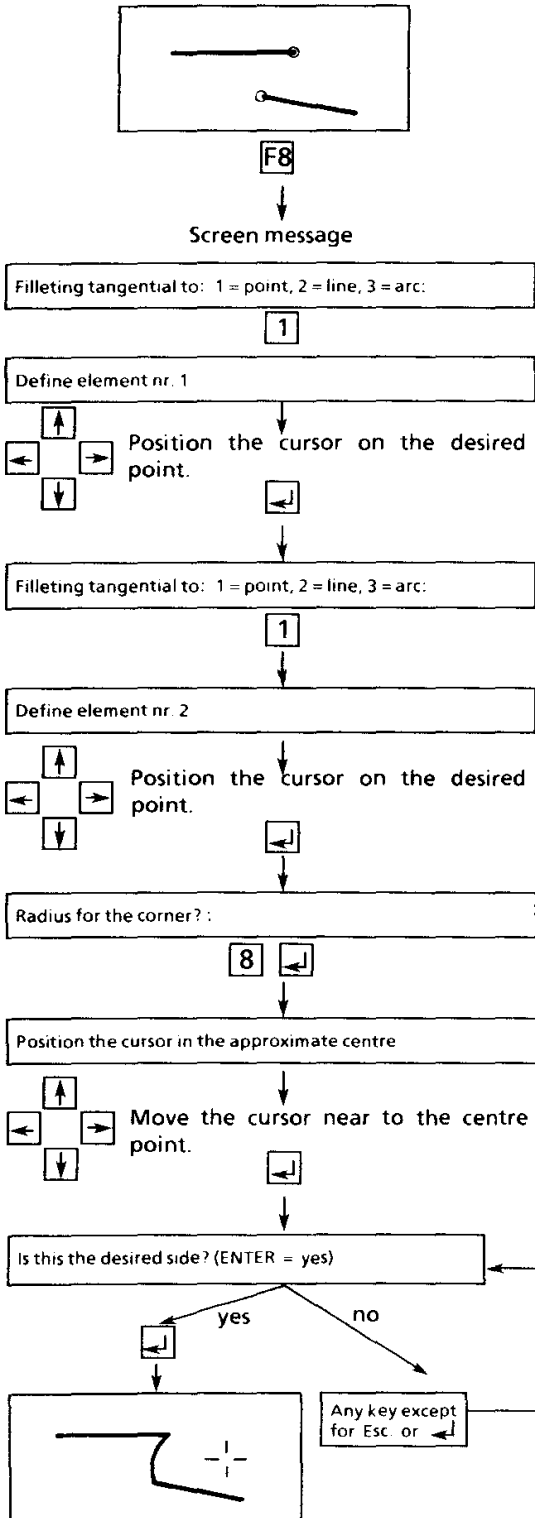

Example 2

Filling the point of a line with a line.

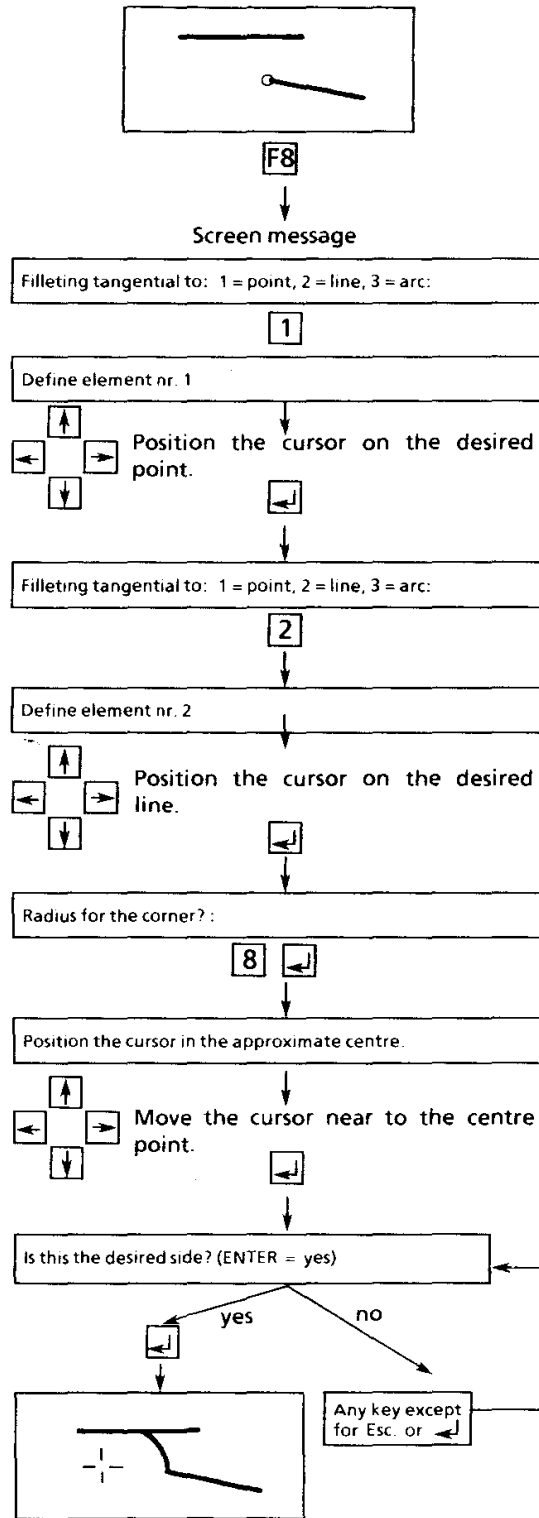

Example 3

Filling the point of a line with an arc.

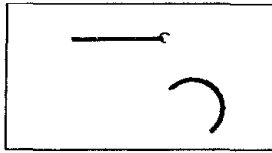

F8

Screen message

Filleting tangential to: 1 = point, 2 = line, 3 = arc:

1

Define element nr. 1

Position the cursor on the desired point.

Filleting tangential to: 1 = point, 2 = line, 3 = arc:

3

Filleting type?: 1 = before the arc, 2 = include the arc:

1

Define element nr. 2

Position the cursor on the desired circle.

Radius for the corner?:

6

Position the cursor in the approximate centre

Move the cursor near to the centre point.

Is this the desired side? (ENTER = yes)

yes

no

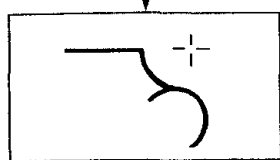

Any key except for Esc. or

Example 4

Filling a straight line with an arc.

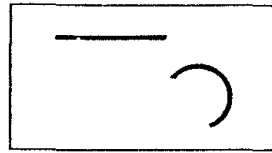

F8

Screen message

Filleting tangential to: 1 = point, 2 = line, 3 = arc:

2

Define element nr. 1

Position the cursor on the desired line.

Filleting tangential to: 1 = point, 2 = line, 3 = arc:

3

Filleting type?: 1 = before the arc, 2 = include the arc:

1

Define element nr. 2

Position the cursor on the desired circle.

Radius for the corner?:

6

Position the cursor in the approximate centre

Move the cursor near to the centre point.

Is this the desired side? (ENTER = yes)

yes

no

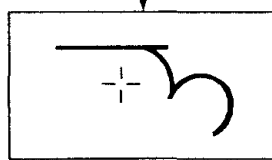

Any key except for Esc. or

#### 4.2.5 Drawing visible edges (circumferential edges) (F5)

Drawing in the visible edges is not required for the production on a lathe; it only serves to create a complete representation according to the standards.

Procedure:

- The cursor was positioned near to the desired visible edge.
- The visible edge is drawn up to the Z axis, when the key F5 is pressed.
- This procedure is repeated for every visible edge.

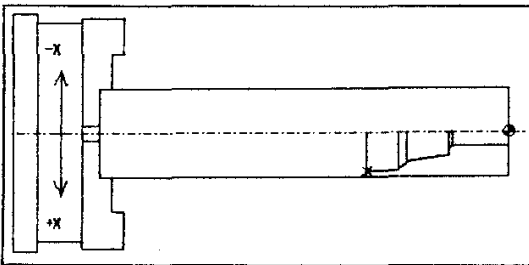

#### 4.2.6 Mirroring the work piece contour (F6)

Only the lower half of the work piece must be drawn on the screen for the production on a lathe.

The upper half of the work piece can be created by mirroring around the Z axis.

Procedure

Press F6 key

The command F6 - mirroring remains. This means, that all contour parts programmed after this function are also mirrored.

The command is deselected again, when "F6" is pressed again.

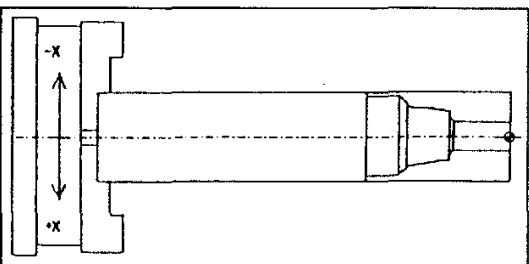

#### 4.2.7 Cleaning the work piece contour (F7)

At the beginning of a geometric definition, it will often be the case that two or more contour elements are cut uncleanly. For the machining of the work piece, however, continuous contours are required. The points of intersection must be "cleaned" (for example, see next page).

Note:

The prompt from the system for the type of contour appears during the cleaning. There are two possibilities.

Possibility 1: open contour

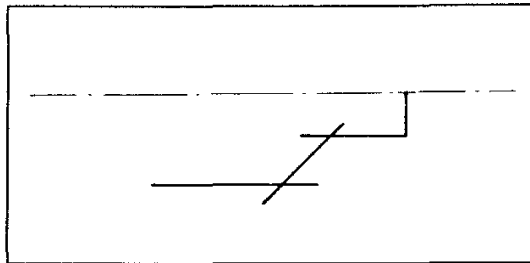

Possibility 2: closed contour

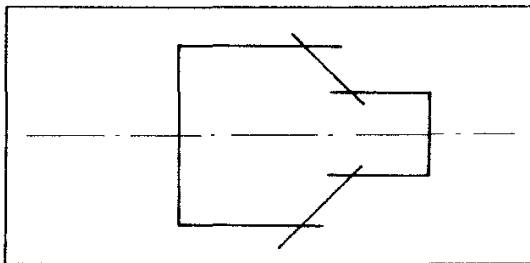

Example: Cleaning

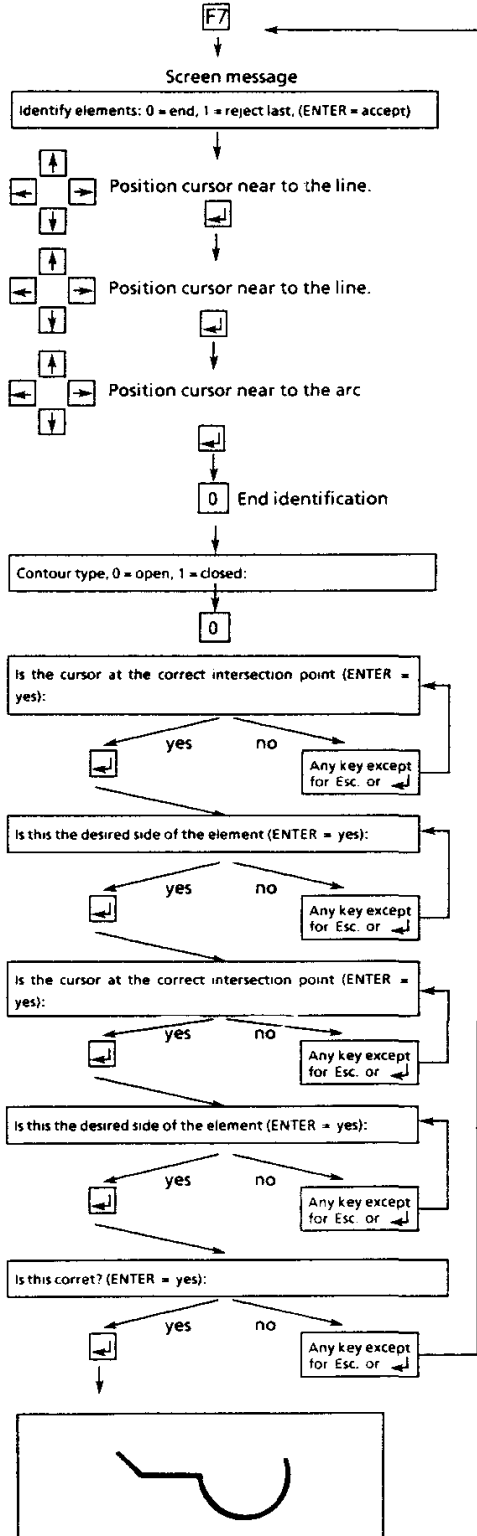
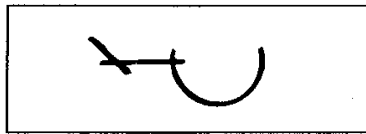

### 4.2.8 Erasing the geometric element (F8)

The cursor was positioned near to the element to be erased (line, circle or arc). The neighbouring geometric element is erased, when the key F8 is pressed.

**Attention!**  
The command "Erase" can no longer be reversed, after it has been carried out.

### 4.2.9 Erasing all (F9)

All the drawing elements shown on the screen are erased.

**Attention!**  
The command "Erase" can no longer be reversed, after it has been carried out.

Screen message	Entry
	F9
Are you sure? (ENTER = yes)	[ENTER]

Possibilities:  
ENTER = drawing is erased  
Any other key = erasion command is interrupted

### 4.2.10 Hotkeys - draw

In order to facilitate a more efficient programming, so-called "hotkeys" were introduced in this software. Hotkey = single-key commands, which are effective in every menu level. You can display a work piece contour on the screen more quickly with the use of these hotkeys.

Example: Constructing a line







Possibility 1 - Menu





1. F2 Recall - menu DRAW
2. F2 Recall - submenu POINT
3. Moving the cursor to the starting point
4. F1 Determining the starting point
5. Moving the cursor to the end point
6. F2 Determining the end point
7. Esc. Exit from the submenu POINT
8. F3 Recall - submenu line
9. F1 Drawing a line





Possibility 2 - hotkeys



1. Moving the cursor to the starting point
2. S Determining the starting point
3. Moving the cursor to the end point
4. + Drawing the line to the cursor position, a new starting point at the same time





#### Summary - hotkeys

Key	Cursor commands
	Position the cursor incrementally
	Position the cursor by entering the radius and angle
	Cursor to the middle of the screen
	Cursor to the reference point
	Doubling the step size of the cursor
	Halving the step size of the cursor

Key	Screen commands
	Redrawing the screen contents
	Zooming a screen window
	Zooming the work piece
	Cursor as a graticule
	Reduced cursor

Key	Searching commands
	Finding the point
	Searching for the line
	Searching the circle, arc
	Searching any point of intersection

Key	Point commands
	Determining the starting point
	Determining the end point
	Determining the centre point

Key	Geometric commands
	Adding a fillet
	Adding a chamfer (45°)
	Cleaning the bit
	Drawing a line to the cursor
	Erasing the element

Note:  
Letters can be entered as capitals or small letters.

Specimen example 1

Creating a work piece with F1

∅ = 22 mm, length = 100 mm, no bore hole

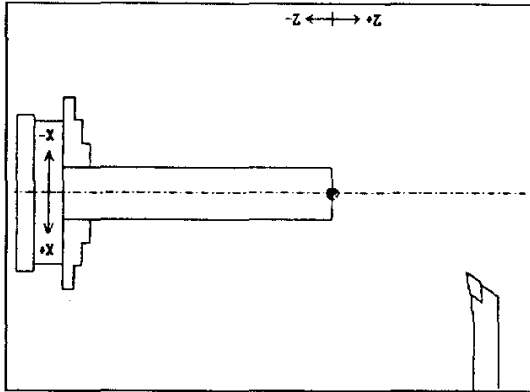

The work piece is enlarged over the whole of the screen surface by means of the hotkey **[Z]**.

Adding the visible edges with F2, submenu F5

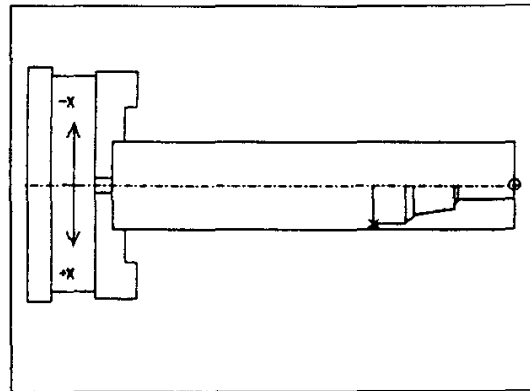

Reflecting the work piece contour with F2, submenu F6

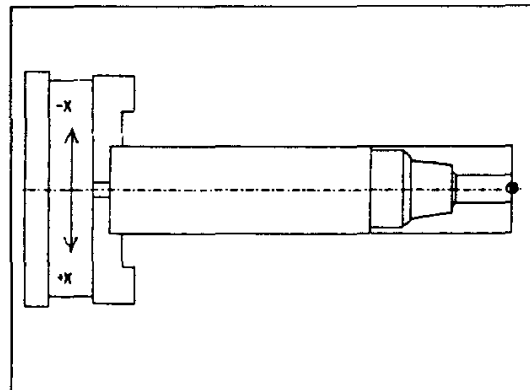

Creating the lower half of the work piece contour with F2

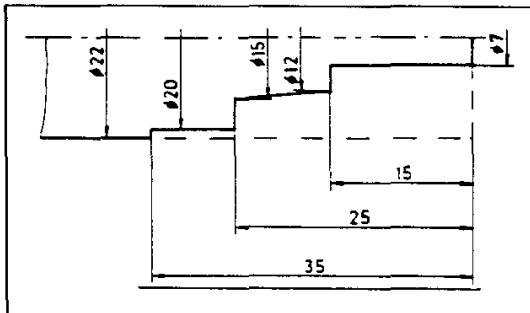

Storing the work piece contour with F8

Adding the radii and chamfers with F2

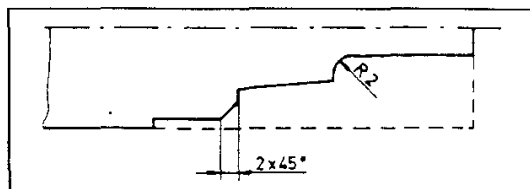

**Specimen example 2**

**Creating a work piece with F1**

Ø = 22 mm, length = 100 mm, no bore hole

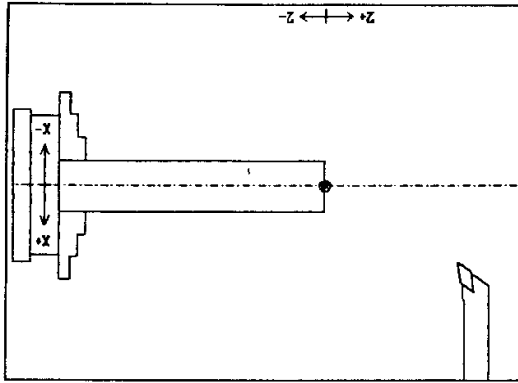

The work piece is enlarged over the whole of the screen surface by means of the hotkey **Z**

**Adding the visible edges with F2, submenu F5**

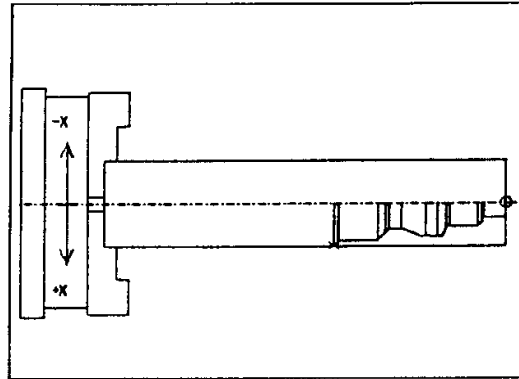

**Reflecting the work piece contour with F2, submenu F6**

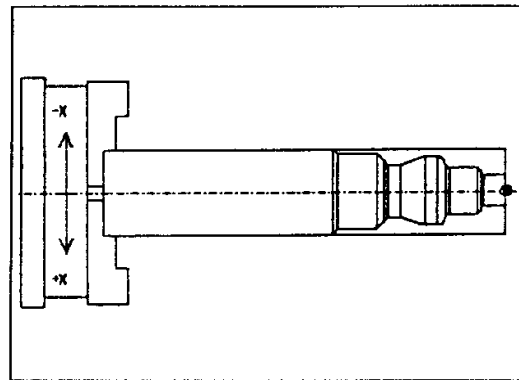

**Creating the lower half of the work piece contour with F2**

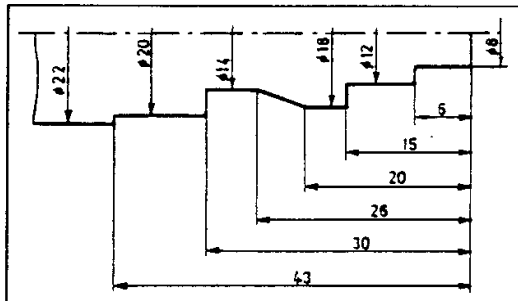

**Adding the radii and chamfers with F2**

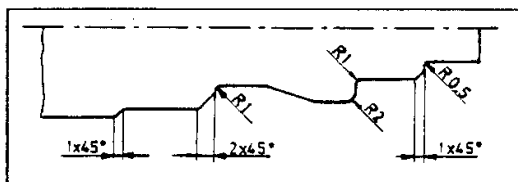

**Storing the work piece contour with F8**



Specimen example 3

Creating a work piece with F1  
 $\varnothing = 22 \text{ mm}$ , length = 100 mm, no bore hole

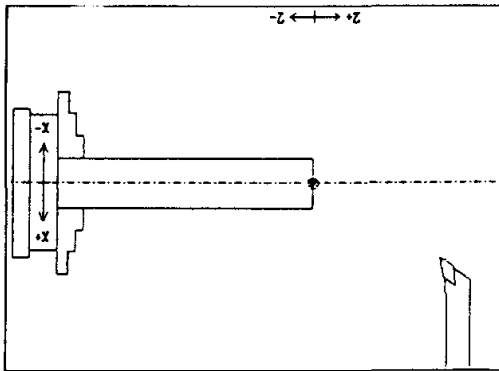

The work piece is enlarged over the whole of the screen surface by means of the hotkey **Z**.

Adding the visible edges with F2, submenu F5

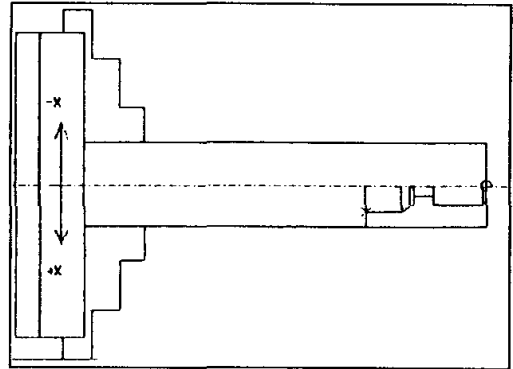

Creating the lower half of the work piece contour with F2

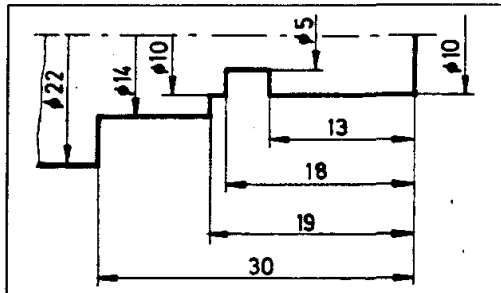

Reflecting the work piece contour with F2, submenu F6

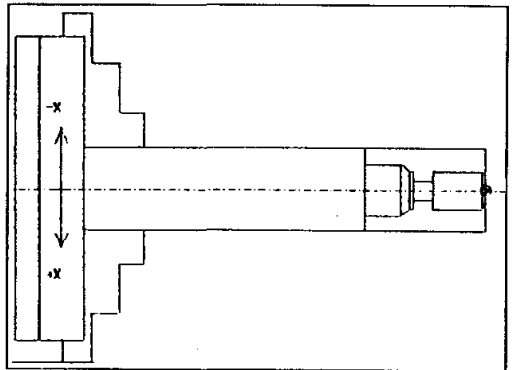

Adding the radii and chamfers with F2

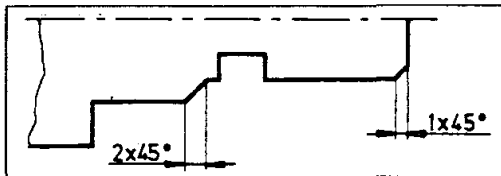

Storing the work piece contour with F8

### 4.3 Program (F3)

The machining cycle is determined for a work piece drawn and simulated on the screen in this menu. The tool path is shown graphically. The machining program is compiled automatically.

The tool moves to the cursor position with the feed speed set to the time (see F9), when the key F2 is pressed.

PROGRAM	
F1	RAPID
F2	FEED
F3	CYCLES
F4	EDITOR
F5	TOOL CHNGE
F6	ERASE LAST
F7	ERASE PROG
F8	FEED
F9	G94/G95
F10	OFFSET

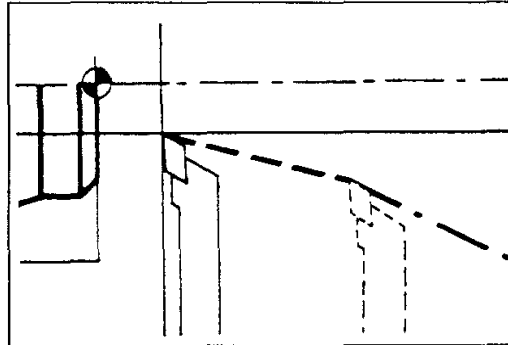

#### Possibilities PROGRAM

##### 4.3.1 Moving in the rapid (F1)

Moving in the rapid is a movement without chip removal and only serves to position the tool. The slides move with the highest possible speed (200 mm/min).

Representation on the screen: - - - - -

The tool moves to the cursor position in the rapid, when the key F1 is pressed.

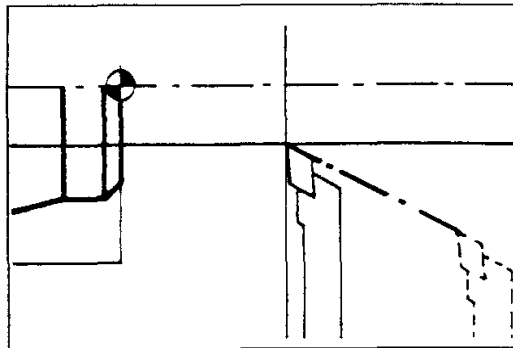

##### 4.3.3 CYCLES (F3)

PROGRAM	
F1	ROUGHING
F2	BACK POCKET
F3	CONTOUR
F4	CUT-IN
F5	THREAD
F6	
F7	
F8	
F9	
F10	

A cycle is a pointed tool movement, which is enclosed and composed of many parts. A circle is composed of the rapid and feed movements or thread-cut movements.

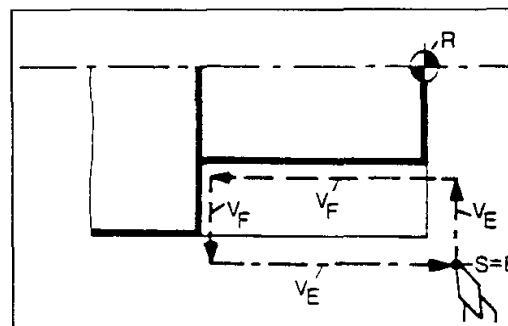

##### 4.3.2 Moving with feed speed (F2)

The slides move with the programmed feed speed (= machining movement, see F9).

Representation on the screen: - - - - -

- S = Starting point
- E = End point
- V<sub>F</sub> = Feed speed
- V<sub>E</sub> = Rapid speed

## Roughing cycle (F1)

The roughing cycle is a movement sequence, where the "coarse contour" of the work piece is machined with the greatest possible chip removal.

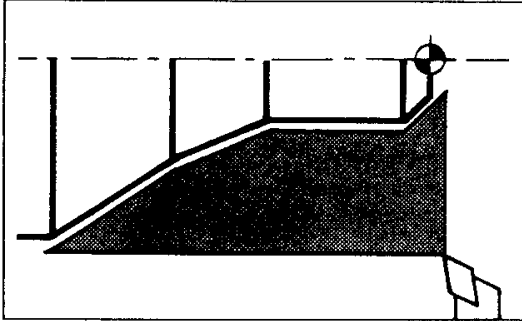

If your work piece is designed in such a way that the diameter of the work piece contour decreases to the left, this is not taken into consideration by the roughing cycle. This work piece area must be back pocketed in its own machining procedure.

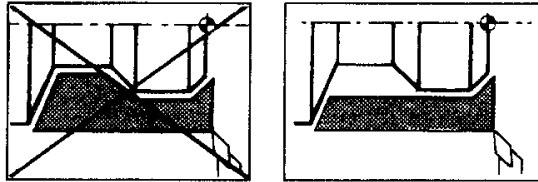

### Condition

The work piece contour created in the menu draw may not be interrupted, since otherwise an interruption of the roughing cycle takes place.

### Procedure

1. Position the tool in the rapid (F1) or with the feed speed (F2) on a sensibly selected starting point (A) of the cycle and press F3.

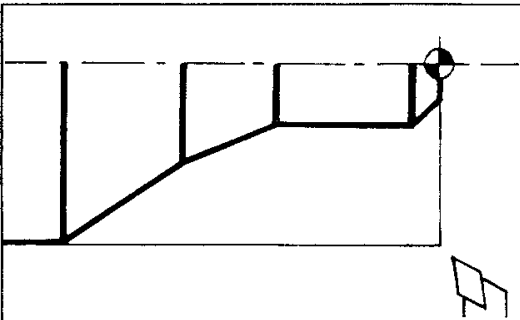

## 2. Determining the starting point

The starting point (S) of the roughing cycle must always be the outermost point on the work piece contour in the Z direction.

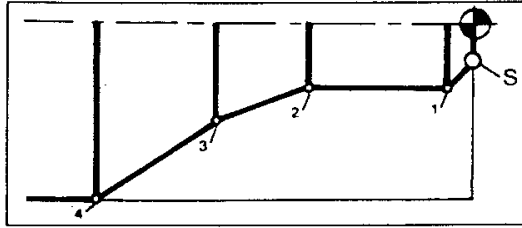

Examples: Starting point for roughing cycles

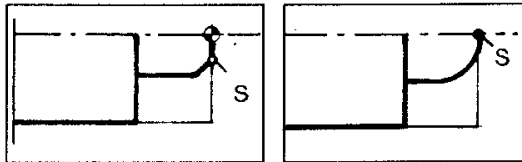

If F3 - roughing cycle is pressed, the point nearest to the cursor is suggested by the program as the starting point.

Possibilities

- Confirm the starting point
- Any key Another point is suggested as the starting point.

## 3. Determining the contour points

After the starting point has been determined, the contour points (1, 2, ...) of the work piece contour drawn must be determined. These contour points are suggested to you.

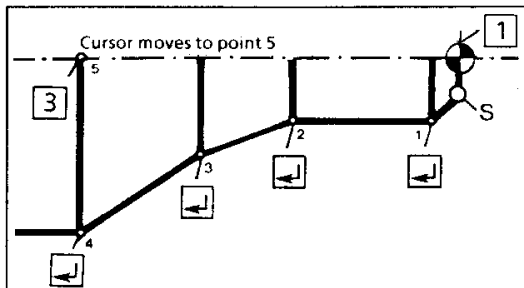

Possibilities

- Confirm the contour point
- 1 Display the next contour point in the opposite direction
- 2 Omit the suggested contour point
- 3 End of the contour point determination, if all contour points have + been made known to the program.

You can also confirm the points of a back pocket, but these are not taken into account by the roughing cycle and must be machined with back pocket cycles.

4. Entering the technological data

After the contour points have been determined, the following prompts appear on the screen one after the other.

Screen display	Entry example
Finishing offsets [mm] X=0, Z=0	0.1, 0.2
In-feed per cut 1 mm	0.8
Feed speed 150 mm/min	

Either confirm the suggested values with ENTER or enter new values.

The values confirmed here are suggested for the following machining variants (back pocket, follow contour).

The data for X values refer to the radius and not to the diameter of the work piece.

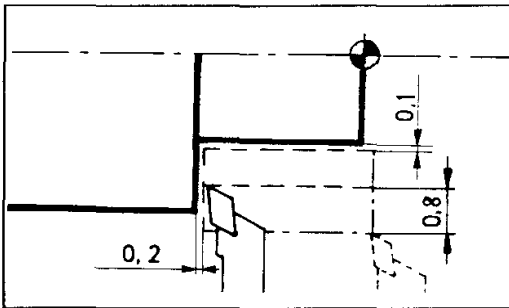

After entering the feed speed, the finishing cycle is processed on the screen. If it is not processed, there are the following causes of errors:

1. No enclosed contour (line draw).
2. Incorrect definition of the contour points.
3. The finishing offset is larger than the contour to be machined.
4. The cutting depth is larger than the contour to be machined.

Example - Roughing cycle

Call up the specimen example 2 (from page 72). Position the tool near to the work piece. Position the cursor near to the starting point.

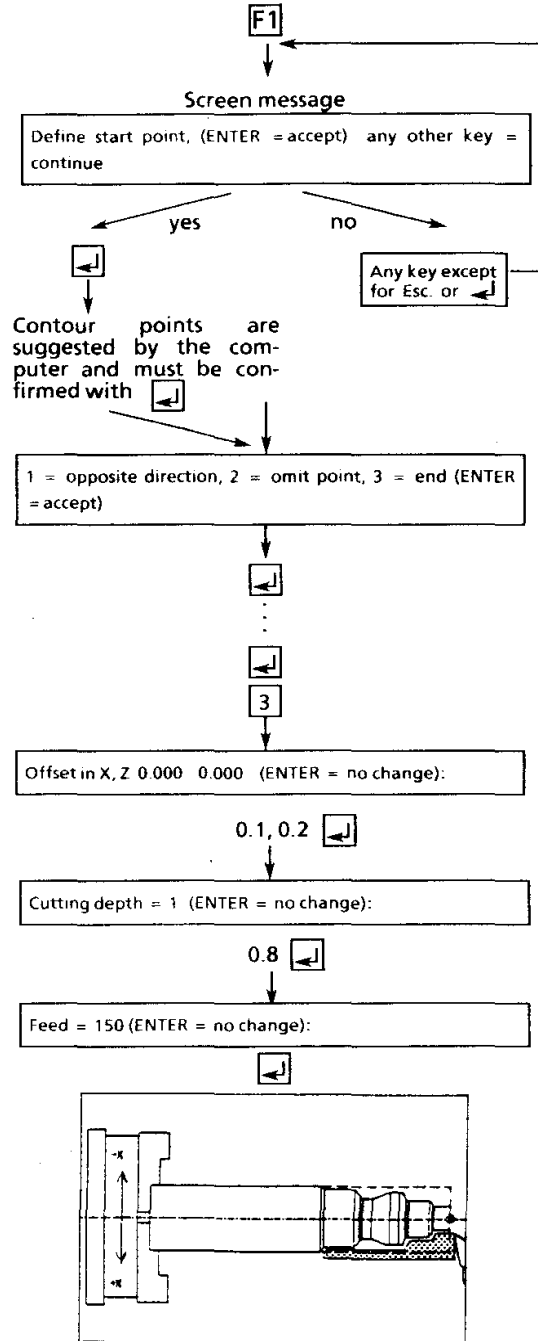
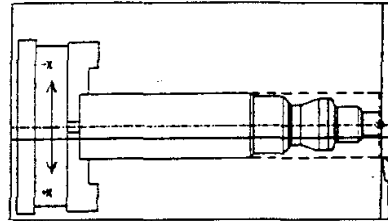

## Back pocket (F2)

Machining a work piece area, which was not taken into consideration by the roughing cycle (work piece diameter decreases to the left).

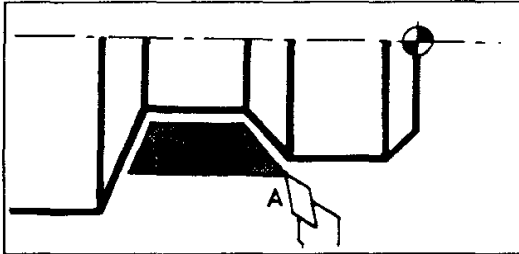

### Condition

The work piece contour created in menu draw may not be interrupted, since otherwise an interruption of the back pocket takes place.

### Procedure

1. Position the work piece on a sensibly selected starting point (A) in the rapid (F1) or in the feed speed (F2) and press F4.

### Note

If a cycle was previously machined, the following message appears on the screen:

New or last contour (ENTER = last):

Re-machine the last defined contour.

Defining a new contour.

### 2. Determining the starting point

The starting point (S) of the back pocket must always be the outermost point of the machined contour in the Z direction.

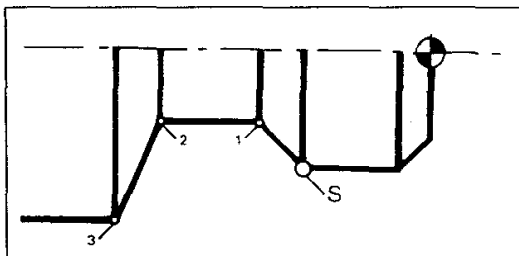

If F2 - back pocket is pressed, the point next to the cursor is suggested by the program as the starting point.

Possibilities:

Confirm the starting point

Another point is suggested as the starting point.

### Examples - Starting point for back pockets



### Special case for turning out an arc with two different tools

#### Procedure

- Split the arc (point T)
- Draw the auxiliary line (H) from the splitting point (T) to the starting point (S1).

Reason: The tool would otherwise cut above the arc and collide.

- Put an additional point (P) on the arc (or on the line).

Reason: In this way, you can determine whether the tool is to travel the path S1 - T (= arc) or the path S1 - P - T (= line) during the determination of the contour points.

- Carry out the back pocket with the right lateral tool.

Starting point .... S1

Following contour points .... T, P, S1

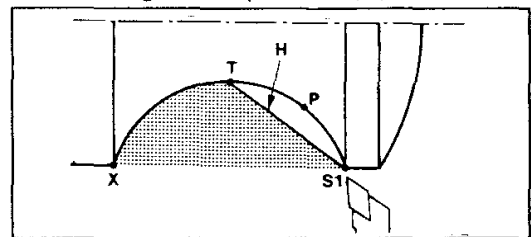

- Change the tool and move to the new starting point (S2).

- Machine the rest from T to S1 with the roughing cycle (there is no more back pocket).

Starting point .... S2

Following contour points ... T, P, S1

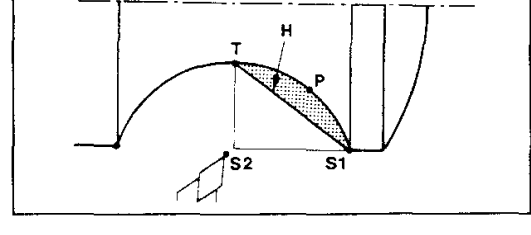

**Attention!**

Arcs (larger than 90°), which are back pocketed, must be split before the machining (see page 64).

**Reason**

The system only recognizes the starting and end points of the arc. A new starting point must be defined for the back pocket. (The starting point of the back pocket is the point, which has come into being, when the arc was split.)

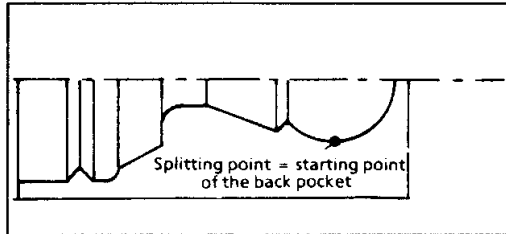

**3. Determining the contour points**

After the starting point was determined, the contour points (1, 2,...) of the back pocket drawn must be determined. These contour points are suggested to you.

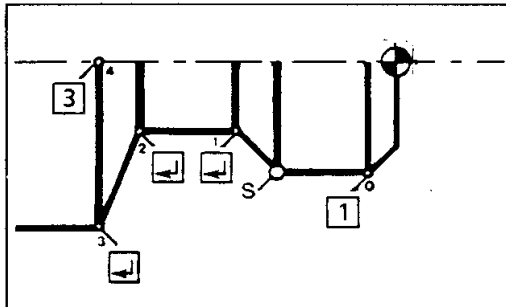

**Possibilities**

- ..... Confirm the contour point
- ..... Display the next contour point in the opposite direction
- ..... Omit the suggested contour point
- ..... Finish the contour point determination

The last contour point of the back pocket must lie on the same level in the X direction or higher than the starting point.

**4. Entering the technological data**

This is carried out in the same way as described in the chapter "roughing cycle".

**Example - Back pocket**

The specimen example 2 (from page 72) is called up. The menu point roughing was carried out. Move the tool near to the starting point of the back pocket. Position the cursor near to the starting point.

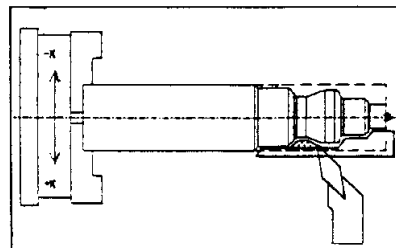
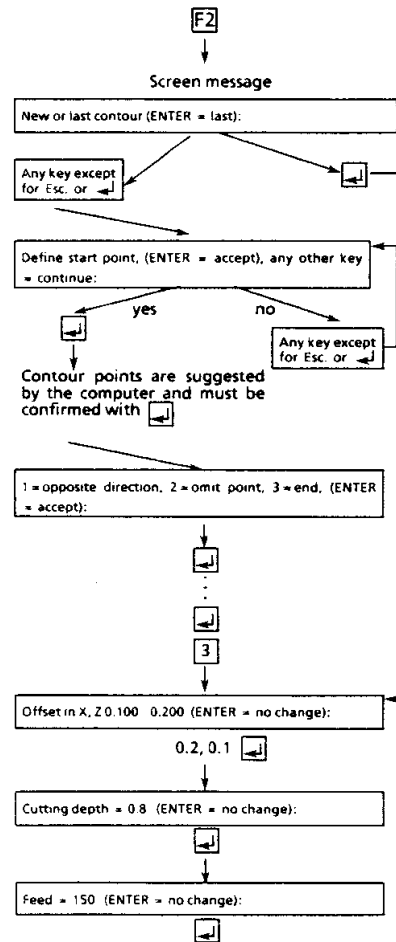
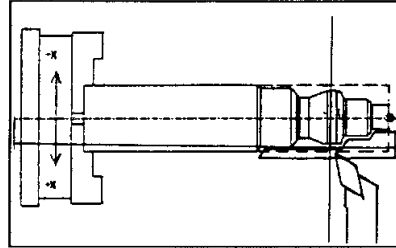

### Follow contour cycle (F3)

If a finishing offset was determined in the menu points roughing or back pocket, this is machined with the follow contour cycle.

Finishing = Dimension-accurate finishing of the work piece contour

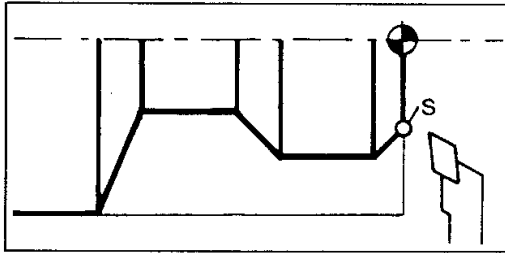

#### Procedure

1. Position the tool near to the starting point (S) in the rapid (F1) or with the feed speed (F2) and press F3.

#### Note

If a cycle was previously machined, the following message appears on the screen:

New or last contour (ENTER = last):

Re-machine the last defined contour.

Define the new contour.

#### 2. Determining the starting point

The starting point of the follow contour cycle must always be the outermost point on the machined contour in the Z direction.

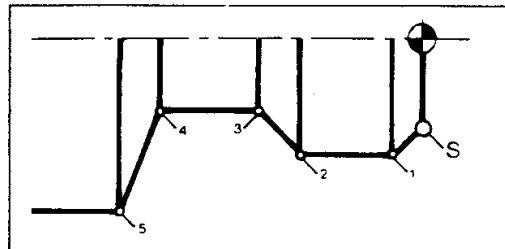

S ..... Starting point

If F3 - follow contour is pressed, the point nearest to the cursor is suggested as the starting point.

#### Possibilities



Confirming the starting point



Another point is suggested as the starting point.

#### 3. Determining the contour points (1, 2, 3, 4, 5)

After the starting point has been determined, the contour points of the work piece contour drawn must be determined. These contour points are suggested to you.

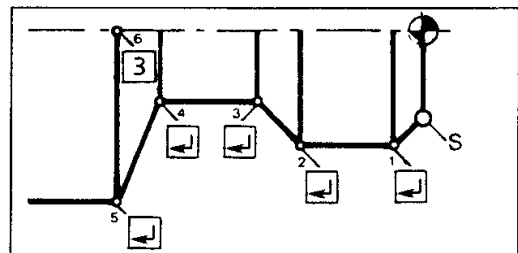

#### Possibilities



..... Confirming the contour point



..... Displaying the next contour point in the opposite direction



..... Omitting the suggested contour point



..... Ending the contour point determination

#### Note

Only the points of the machining, which can be finished with the selected tool, are confirmed as contour points.

E.g., the holes (point 3, 4, 7, 8) may not be confirmed.

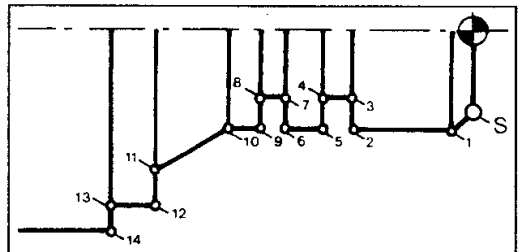

#### 4. Entering the technological data

The input of the finishing offset and feed speed is carried out exactly as described in the chapter "roughing cycle".





### Cut-in cycle (F4)

With this cycle a cut-in can be produced.

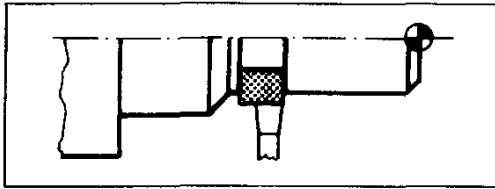

**Procedure:**

1. Select cut-in tool (see menu PROGRAM/CHANGE TOOL - F5)
2. Place the cut-in tool with rapid motion (F1) or feed speed (F2) at the level (direction X) of the initial point of the cycle (A) and press F3.

**Note:**

You have to place the cut-in tool only in direction X at the initial point (A) of the cut-in cycle. Before working-off the cycle the tool moves automatically to the initial point in direction Z.

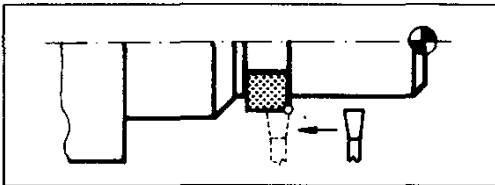

**3. F4 - select cut-in cycle**

**4. Determine the starting point**

If the key F4 was pressed, the following message appears on the screen:

Identify starting point for cut-in.

By using the cursor keys move next to the starting point (S) and confirm with ENTER.

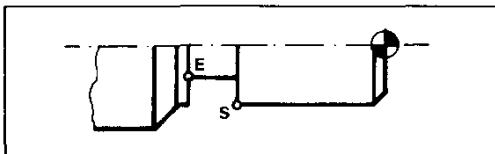

**5. Determine final point:**

After determining the starting point the following message appears:

Determine final point for cut-in:

By using the cursor keys move next to the final point (E) and confirm with ENTER.

**6. Enter technological data:**

After having determined the starting and the final point of the cut-in off the following inquiries appear on the screen in series:

Screen message	Input
Enter cutter width	3 <input type="text"/>
Enter feed in mm/min = 150	70 <input type="text"/>
Enter infeed depth	1 <input type="text"/>

**7. Confirm inputs:**

After entering the technological data the following message appears on the screen:

End of input (ENTER = accepted):

**Possibilities:**

- The cut-in cycle is worked off.
- Any key Exit

**Example cut-in cycle:**

Training example 3 is called up. Menu point 3 roughing and contour sequences have been executed. The cut-in tool has been selected and moved next to the starting point of the cycle.

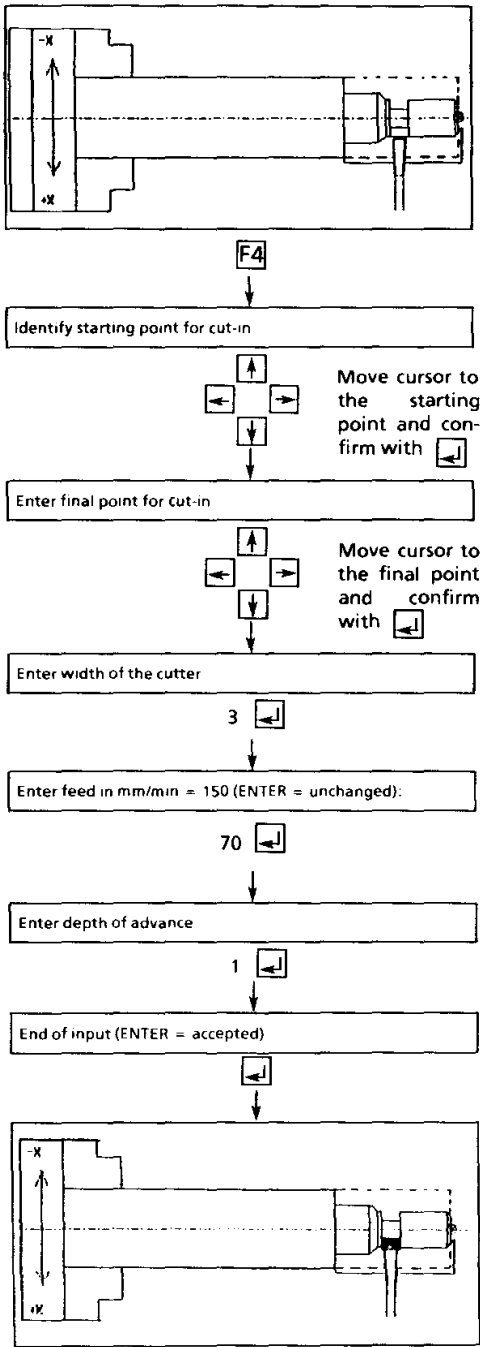

## Threading cycle (F5)

### Possible threads:

- With this machine you can tap and thread right-hand and left-hand threads.
- Possible thread pitches:  
PC/AT: 0,5 - 3 mm (0,025" - 0,11")  
PC/XT: 0,5 - 1,5 mm (0,025" - 0,062")
- Metric threads:  
PC/AT: M3 - M24  
PC/XT: M3 - M10
- Inch threads:  
PC/AT: 0,112" - 3/4"  
PC/XT: 0,112" - 3/8"
- Flank angle 60° (with threading tool supplied)
- Speed: Smallest speed range

### Theoretical knowledge

#### Function of thread-cutting

At each workpiece revolution the threading tool has to advance at a certain length (= threading pitch P). For this the main spindle and the slide feed have to be synchronized.

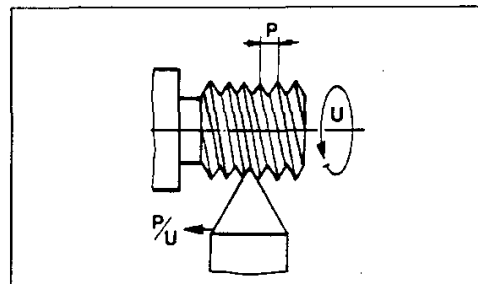

#### Finding of thread turn

A thread is always cut in several operations. At the start command for thread-cutting the main spindle must have a certain angular position. At the start command for the next screw the main spindle must have the same angular position, so that the threading tool finds its way into the thread turn.

## Synchronization of speed and feed

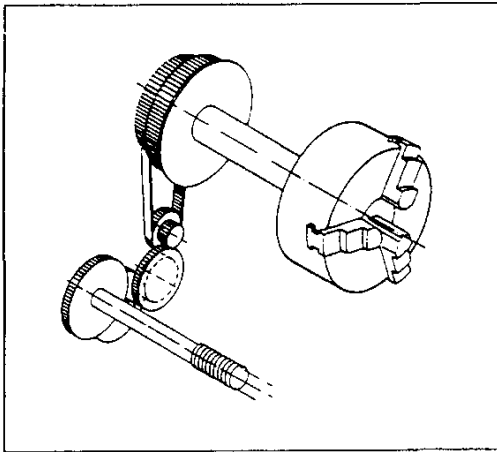
Hand-operated lathe

With a hand-operated lathe the slide feed is carried out from the main spindle via toothed belts, translating gear wheels and leadscrew to the longitudinal slide. There is a closed, mechanical power flux. If the main spindle turns slower, e.g. because of load, the main spindle turns slower at the same rate. The thread pitch always remains the same.

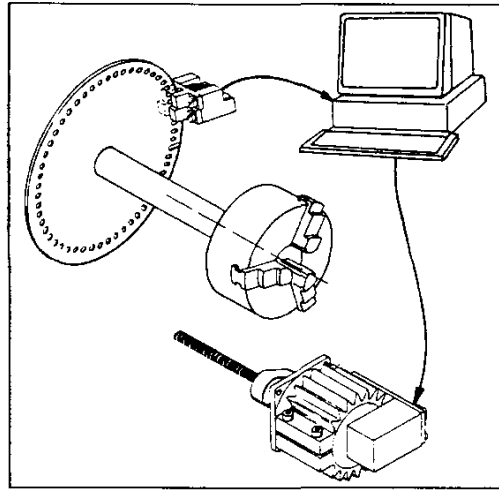
CNC lathe

At the spindle there is an aperture disk with light barrier (= encoder). The encoder reports the respective speed and angular position of the main spindle to the computer.

The computer converts this information and provides the necessary impulses for start and feed speed to the feed motor of the longitudinal slide.

## Thread design

When conforming to standard metric ISO threads a separate radius of curvature (R1) is assigned to each thread pitch.

This means that for each pitch a separate threading tool is needed.

Solution:

On this machine we use a threading tool with a radius  $R2 = 0,04$  mm for all pitches from 0,5 to 2 mm.

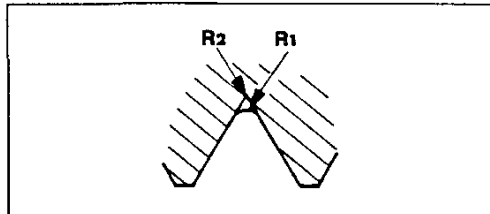

Disadvantage:

The radius of curvature R2 does not conform to standard. The thread turns become a little deeper, thus resulting in a smaller core diameter (see tables) than with standard threads. These threads naturally can be screwed with standard screws and nuts.

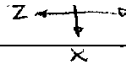

### 3. Design of a thread

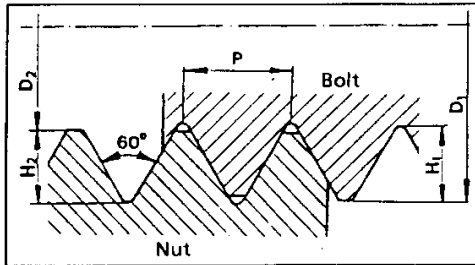

During the design of a thread mind the following items:

#### Thread dimensions

The threads cut in accordance with this table can be screwed with standardized screws and nuts.

Metric threads (dimensions in mm)

Thread designation	Pitch P	Bolt		Nut	
		Nominal diameter $D_1$	Thread height $H_1$	Core diameter $D_2$	Thread height $H_2$
M3	0,5	3,00	0,337	2,459	0,285
M3,5	0,6	3,50	0,416	2,850	0,355
M4	0,7	4,00	0,490	3,242	0,414
M4,5	0,75	4,50	0,529	3,688	0,448
M5	0,8	5,00	0,551	4,134	0,479
M6	1,0	6,00	0,717	4,917	0,609
M8	1,25	8,00	0,907	6,647	0,771
M10	1,5	10,00	1,100	8,376	0,934
M12	1,75	12,00	1,285	10,106	1,098
M14	2,0			11,835	1,257
M16	2,0			13,835	1,257

\* M.. stands for metric standard threads

Inch threads according to US-standard (dimensions in inch)

Thread designation	Turns per inch	Pitch P	Bolt		Nut	
			Nominal diameter $D_1$	Thread height $H_1$	Core diameter $D_2$	Thread height $H_2$
.112 (4)	40	0,0250	0,1120	0,0174	0,0813	0,0147
.125 (5)	40	0,0250	0,1250	0,0174	0,0943	0,0147
.138 (6)	32	0,0313	0,1380	0,0243	0,0997	0,0188
.164 (8)	32	0,0313	0,1640	0,0243	0,1257	0,0188
.190 (10)	24	0,0417	0,1900	0,0330	0,1389	0,0252
.216 (12)	24	0,0417	0,2160	0,0330	0,1649	0,0252
1/4	20	0,0500	0,2500	0,0386	0,1887	0,0309
5/16	18	0,0556	0,3125	0,0447	0,2443	0,0346
3/8	16	0,0625	0,3750	0,0502	0,2983	0,0391
7/16	14	0,0714	0,4375	0,0577	0,3499	0,0449
1/2	13	0,0769			0,4056	0,0485
9/16	12	0,0833			0,4603	0,0526
5/8	11	0,0909			0,5135	0,0576

1" = 25,4 mm

**Chamfer**

Start and end of a thread are usually provided with a chamfer of 45° or 60° to avoid a burr during thread-cutting.

The 30° chamfer can still be turned with the right lateral tool and saves an additional changing of the turning tool.

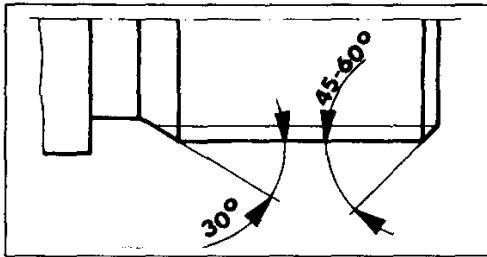

**Design of core diameter for bolts**

- Draw one straight line between starting point (S) and final point (E) with the correct thread height H1 (see table)
- Search intersecting point (X) and delete projecting line

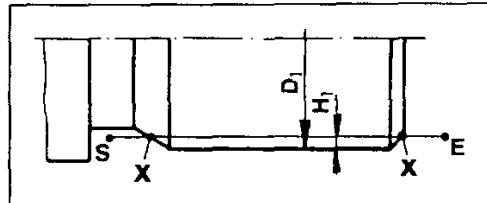

**Design of nominal diameter for nut**

Similar to description for core diameter of bolt.

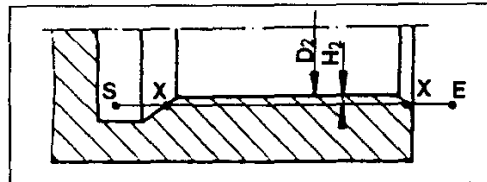

**Thread lead-in - Thread lead-out**

At the start and end of a thread-cutting procedure the slides (with threading tool) have to be accelerated or decelerated.

This acceleration path (approx. 3 mm) and deceleration path (approx. 1 mm) has no constant thread pitch and therefore must be outside of the cutting process. The necessary free space for the turning tool has to be taken into account during the design of the workpiece.

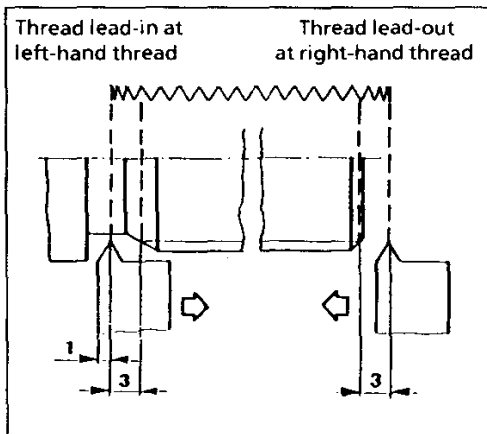

### 4. Machining data

#### Tool change

Select tool for thread-cutting (see menu program - F3/change tool - F6).

#### Enter number of machine cuts

After selecting the thread cycle the following message appears at the screen:

Enter number of machine cuts (10)  
(ENTER = accept):

The recommended number of machine cuts is 10 to 20 according to thread height (H). The software adjusts the feed depth so that at each cut the chip cross-section has the same size. The feeds are carried out only in X-direction.

#### Right-hand thread - left-hand thread

If the tool is at the right side of the thread (A) a right-hand thread is cut. If you move the tool (in rapid motion) to the left side of the thread (B) a left-hand thread is cut.

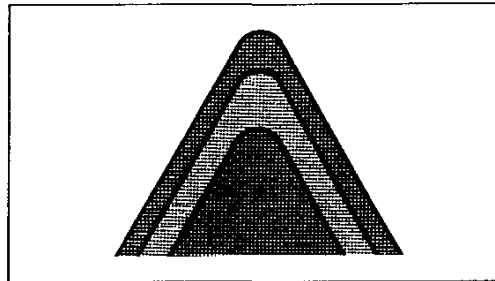
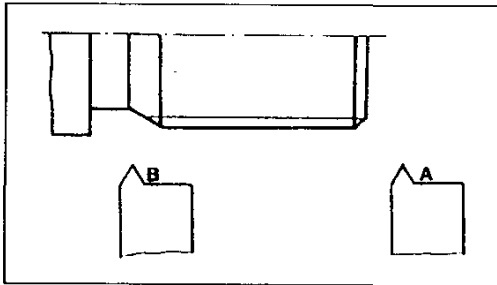

#### Thread lead-in - thread lead-out

Screen message:

Enter thread lead-in = 3.000, lead-out = 1.000  
(ENTER = no change)

For thread lead in a length of at least 3 mm should be entered because the slide (with thread tool) needs an acceleration path. For thread lead-out enter approx. 1 mm. At left-hand threads these values must be provided with a negative sign.

#### Call-up thread cycle

Select the key F3 in the menu program and the submenu CYCLES appears. Select the thread cycle with F4.

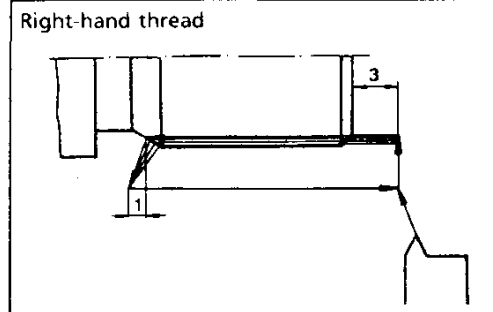
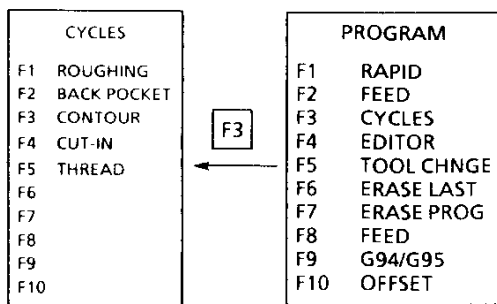

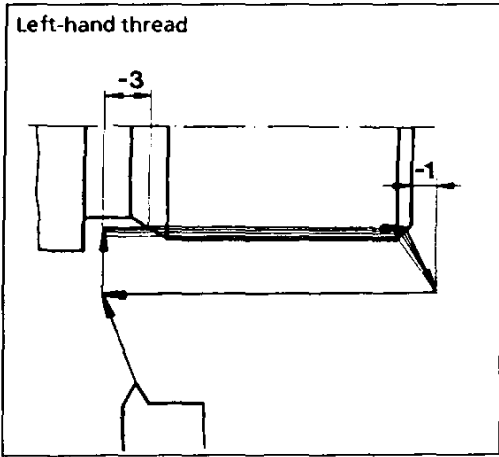

**Acknowledge inputs**

End of input (ENTER = accepted)

You have two possibilities:

The thread cycle is worked off on the screen.

Any key Exit from the thread cycle. The values entered last are suggested at the next call-up of the thread cycle.

**Thread pitch**

Screen message:

Pitch = 1.000 (ENTER = no change):

Thread-cutting tools offered are designed for pitches of  $P = 0,5 - 2$  mm or 11-40 turns per inch. You can see the pitches for standardized threads from the table of the chapter "thread dimensions".

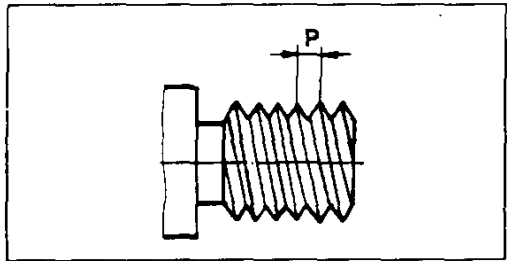

**Notes for working off the thread cycle at the machine**

Speed:  
Adjust the smallest speed range (BC1 = 200 rpm).

**Indicate nominal and core diameter**

Enter nominal diameter element:

Place the cursor to the nominal diameter and acknowledge with ENTER. The following message appears:

Enter core diameter element:

Place the cursor to the core diameter and acknowledge with ENTER.

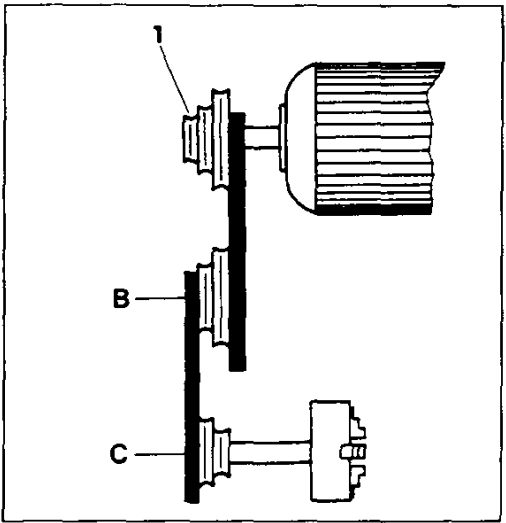



**Example: Generation of a special screw**

- Unmachined part:  $\varnothing 22,100$  with bore  $\varnothing 3,5$
- Drawing:

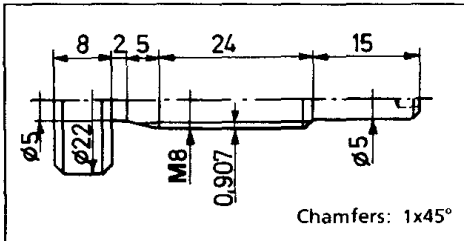

- Roughing
- Back-off
- Execute contour cycle
- Select thread tool
- Position thread-cutting tool at the right side of the thread
- Select submenu "thread"

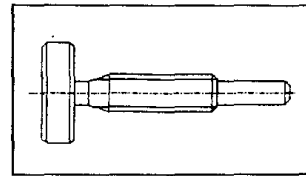

F4

Enter number of machine cuts (10)  
(ENTER = accepted):

15

Enter thread lead in = 3.000, lead out = 1.000  
(ENTER = no change)

↵

Enter pitch = 1.000 (ENTER = no change):

1.25

Enter nominal diameter element:

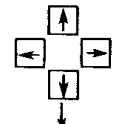

Cursor to nominal diameter and acknowledge with ↵

Enter core diameter element:

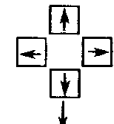

Cursor to core diameter and acknowledge with ↵

End of input (ENTER = accepted)

↵

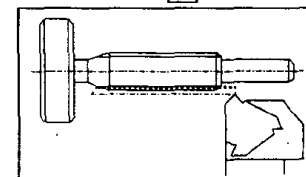

**Important:** During machining and particularly during thread-cutting the work-piece is to be supported in any case by a lathe center.

### 4.3.4 Edit (F4)

By pressing the key F4 you enter the "Edit" program. In Edit you can work in the same way as with the original CNC

machine and set up NC programs according to standards (acc. to DIN 66025 and ISO 1056). For an exact description see chapter 6 "EDIT".

### Machining possibilities (Survey)

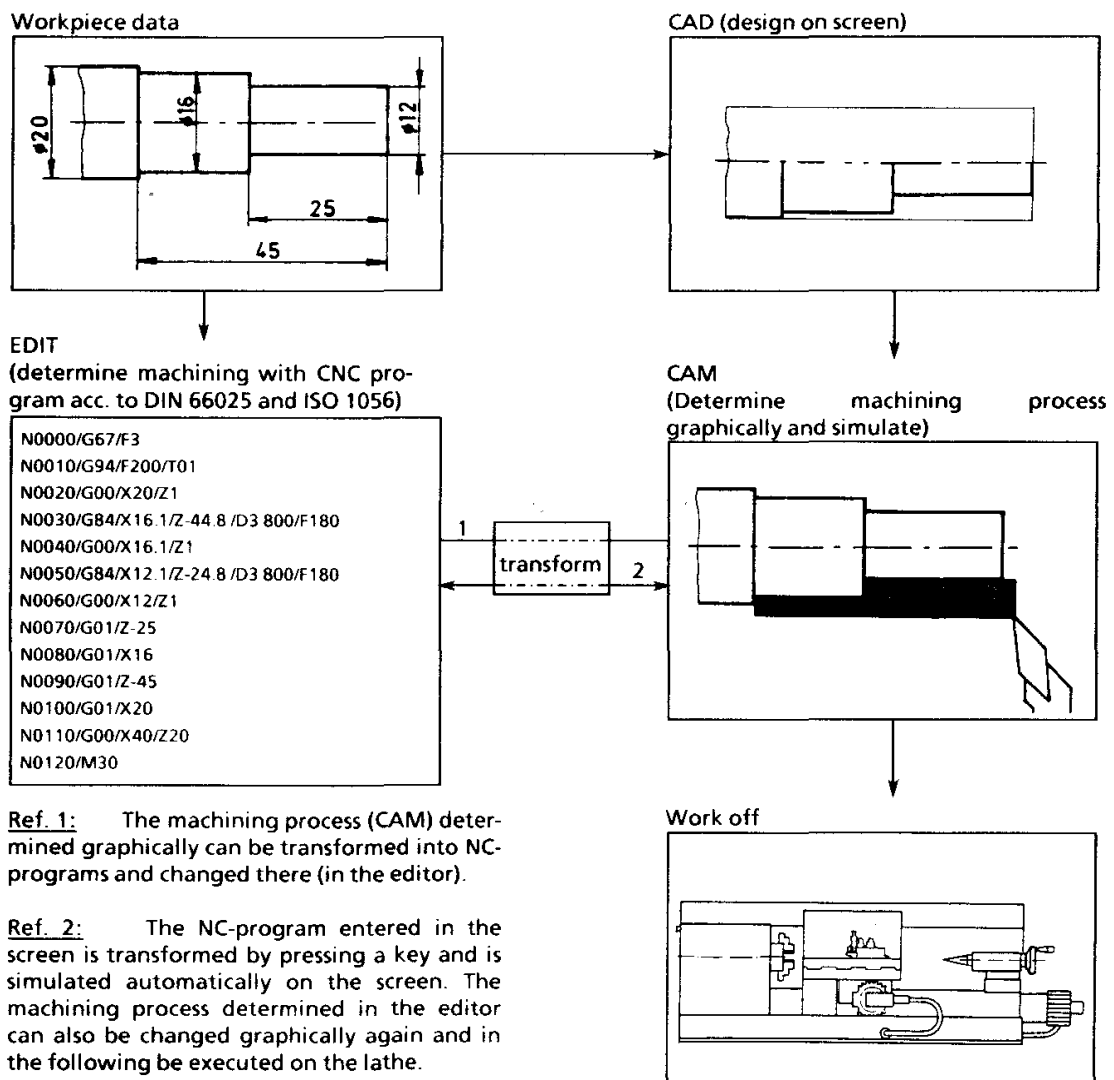



### 4.3.5 Tool change (F5)

#### Tool change during the compilation of the machining program

##### Procedure

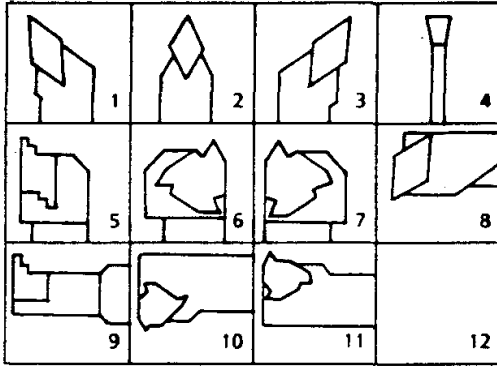
- Move the current tool to a tool change position (with F1 = rapid)
- Press F6, a tool range appears on the screen.



- Select the tool (e.g., 3 )
- The machining program to be compiled can be continued with the new tool after the tool change.
- The travelling movements of the new (active) tool are shown in light blue, those of the old tool in dark blue.

#### Tool change during the processing of a machining program

The machining program remains on the machine during the processing and automatically stops before the tool change on the PC (= intermediate stop).

Carry out the tool change on the PC

1. Select the menu program
2. Press F6
3. Enter the desired tool number and confirm with Enter

Carry out the tool change on the machine

4. Change the tool by hand
5. Select the menu setup and re-synchronize the machine - PC
6. Select the menu machine
7. Select automatic
8. Press enter

### 4.3.6 Erasing the last movement (F6)

The previously entered movement is erased, when the key F7 is pressed.

### 4.3.7 Erasing the machining program (F7)

The complete program is erased.

### 4.3.8 Entering the feed values (F8)

The set feed value for F2 (= moving with feed speed) can be altered, when the key F8 is pressed.

Screen message	Entry
	<b>F8</b>
Feed = 30 (ENTER = no change):	40 

### 4.3.9 Change feed unit (F9)

A feed value can be entered in two different units:

- in mm/min (= G94)
- in mic/r (= G95)  
= 1µm/r = 1/1000 (0.001) mm/r

F (mm/min) = F (mm/r) x S (r/min)													
By pressing the F9 key the feed unit on the screen changes. The adjusted nominal value remains the same.	<table border="1"> <thead> <tr> <th></th> <th>TOOL</th> </tr> </thead> <tbody> <tr> <td>X</td> <td>2.000</td> </tr> <tr> <td>Z</td> <td>5.252</td> </tr> <tr> <td>D</td> <td>4.000</td> </tr> <tr> <td>F</td> <td>1.00/min</td> </tr> <tr> <td>S</td> <td>8 rpm</td> </tr> </tbody> </table>		TOOL	X	2.000	Z	5.252	D	4.000	F	1.00/min	S	8 rpm
	TOOL												
X	2.000												
Z	5.252												
D	4.000												
F	1.00/min												
S	8 rpm												

#### Example:

F = 80 mm/min means: The cutting tool travels 80 mm in one minute, no matter how often the workpiece turns.

F = 80 mic/r means: The cutting tool travels 0,08 mm during one workpiece revolution.

At a speed of e.g. 200 rpm there is a feed of 0,08 mm x 200 rpm = 16 mm/min.

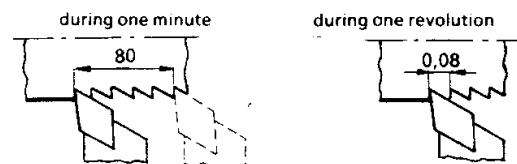

### 4.3.10 Entering the finishing offsets in X and Z (F10)

The set finishing offsets can be altered, when the key F10 is pressed.

#### Note

The entry of the finishing offset in the X direction refers to the radius of the work piece.

Screen message	Entry
	<b>F10</b>
Offset in X, Z 0.100 0.200 (ENTER = no change):	0.05, 0.1 

## 4.4 DISPLAY (F4)

The screen display is determined or altered in this menu.

DISPLAY	
F1	ZOOM ALL
F2	ZOOM WINDW
F3	ZOOM PIECE
F4	HEAD STOCK
F5	WORK PIECE
F6	TOOL
F7	TOOL PATH
F8	TAIL STOCK
F9	CHANGE SIM
F10	

### 4.4.1 Zoom all (F1)

Everything shown on the screen (head stock, work piece, work piece contour, ...) is enlarged, so that it can still be displayed within the screen.

**F1** ... The complete screen area is enlarged.

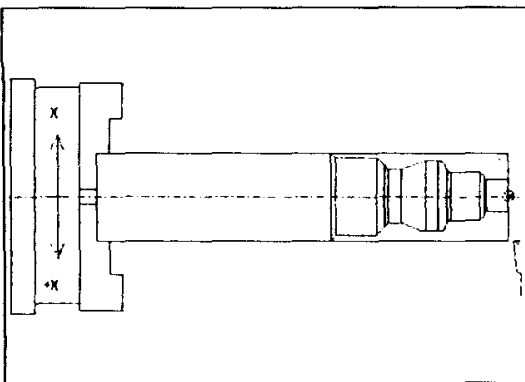

### 4.4.2 Zoom window (F2)

A "screen window" is defined and enlarged across the whole of the screen area.

Two diagonal bits are determined with the cursor keys and ENTER. The right-hand bit defined in this way is then enlarged across the whole of the screen surface.

Example

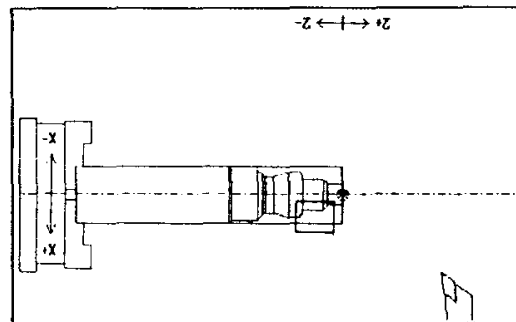

**F2**

Screen message

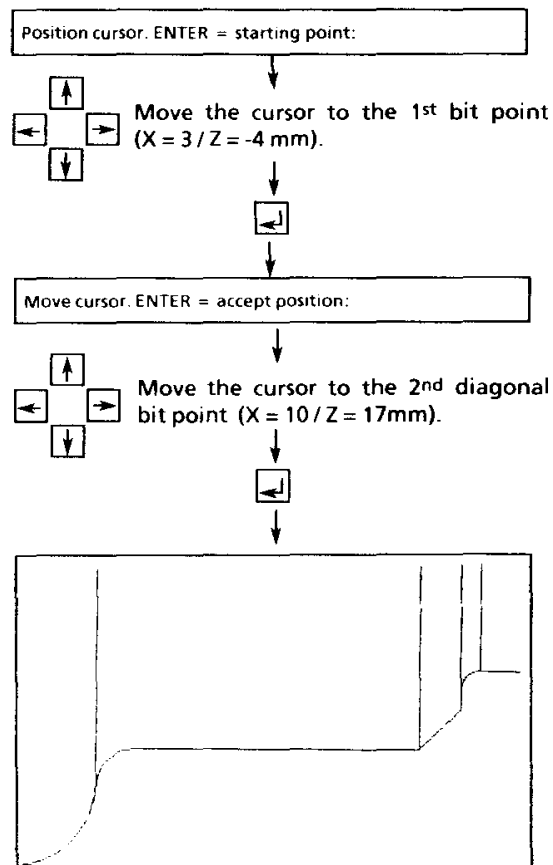

### 4.4.3 Zoom work piece (F3)

The work piece shown on the screen is enlarged, so that it is still shown within the screen, when the key F3 is pressed.

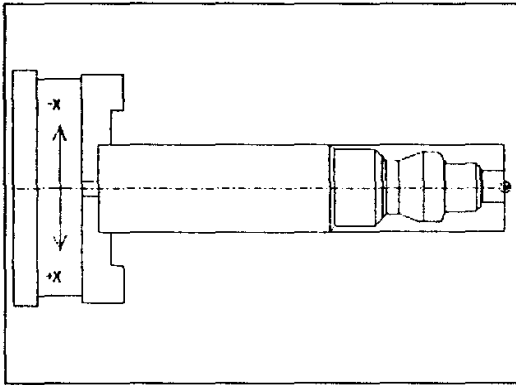

### 4.4.5 Removing, inserting the work piece (F5)

The work piece shown on the screen can be removed with the key F5.

The work piece can be re-inserted, when F5 is pressed again.

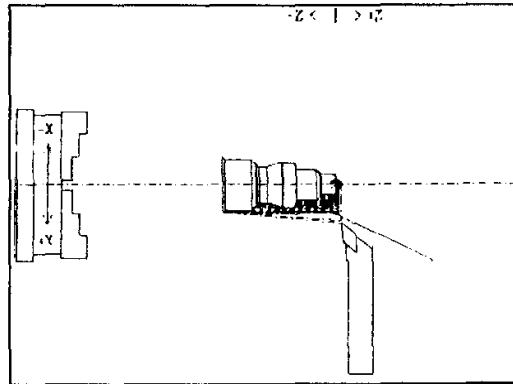

### 4.4.4 Removing, inserting the head stock (F4)

The head stock shown on the screen can be removed with the key F4.

The head stock is re-inserted, when F4 is pressed again.

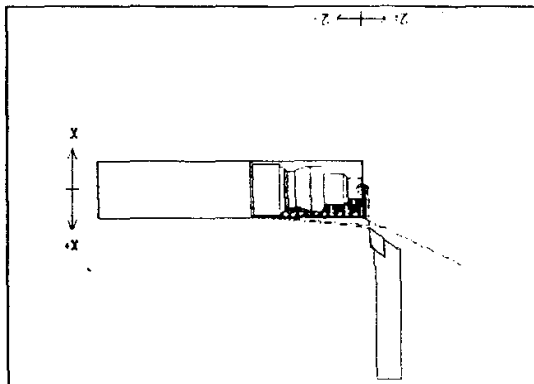

### 4.4.6 Removing, inserting the tool (F6)

The tool shown on the screen can be removed with the key F6.

The tool is re-inserted, when F6 is pressed again.

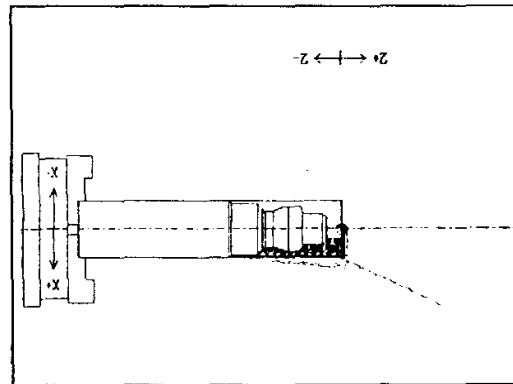

#### 4.4.7 Removing, inserting the tool path (F7)

The tool path shown on the screen can be removed with the key F7.

The tool path is re-inserted, when F7 is pressed again.

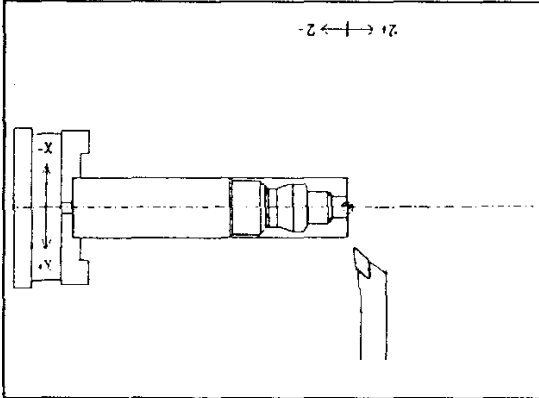

#### 4.4.8 Inserting, removing the tail stock (F8)

The tail stock can be inserted on the screen with the key F8.

The tail stock is removed again, when F8 is pressed again.

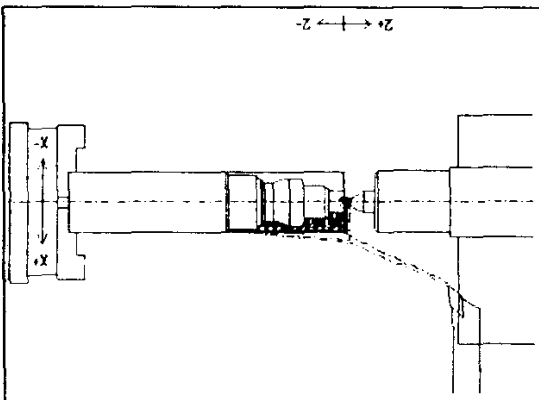

#### 4.4.9 Changing the simulation display (F9)

You can select two simulation displays with the key F9.

1. Displaying the tool path  
(= basic setting)

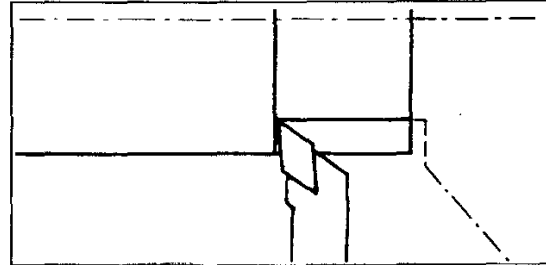



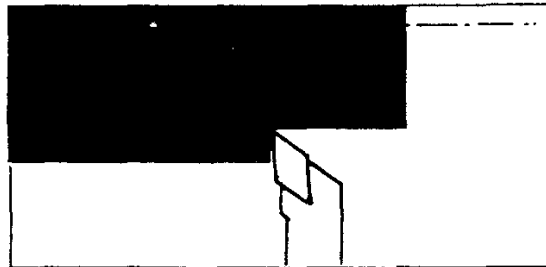







2. Simulating the cutting





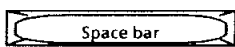



### 4.4.10 Hotkeys - machine













You can move the slides and influence the machining cycles by means of these keys.

	Move the slides in the -X direction
	Move the slides in the + X direction
	Move the slides in the -Z direction
	Move the slides in the + Z direction
	Enlarge the travel path of the stepping motors
	Reduce the travel path of the stepping motors
	Increase the feed
	Reduce the feed
	Stop the slides (= intermediate stop)
	Interrupt the machining

#### Travel path of the stepping motors

	10 mm (= largest travel path)
	5 mm
	1 mm (= switch-on condition)
	0,5 mm
	0,1 mm
	0,05 mm
	0,01 mm (= smallest travel path)

#### Altering the programmed feed

	200 %
	150 %
	120 %
	100 % (= switch-on condition)
	80 %
	60 %
	50 %
	40 %
	30 %
	20 %
	10 %
	5 %
	0 %

### 4.5 Set up 0,0 (F5)

The measuring system of the machine and the PC must be synchronized with one another. This is carried out with the "scratching" (on the diameter and the length) of the clamped work piece.

**Note**

You must synchronize the machine and PC, before you select the menu points MANUAL or MACHINE.

**Procedure**

- Press F5
- Switch on the main spindle
- Move the tool with the arrow keys (see hotkeys - machine) to the diameter of the clamped work piece (in rapid) and "scratch" the work piece.

**Note**

In order to position the work piece exactly, you must reduce the step size with the  key.

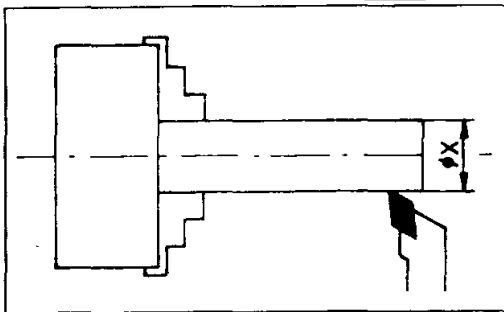

- After reaching the desired diameter, press the enter key.
- Enter the X value (diameter values) of the work piece and confirm it.
- Move the tool with the arrow keys to the face of the clamped work piece and "scratch" the face of the work piece.

**Note**

In order to position the tool exactly, you must reduce the step size with the  key.

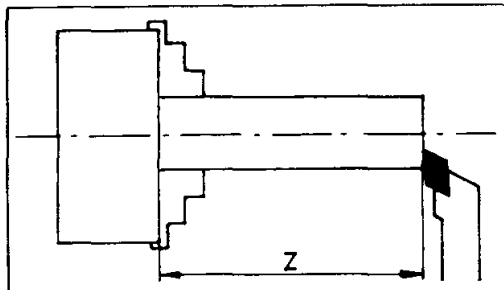

- After reaching the desired length, press enter.
- Enter the Z value (length) of the work piece.

- The measuring system of the machine and PC is now synchronized. You can process your compiled machining program on the machine.

**Example**

Workpiece Ø 20 mm, length = 100 mm

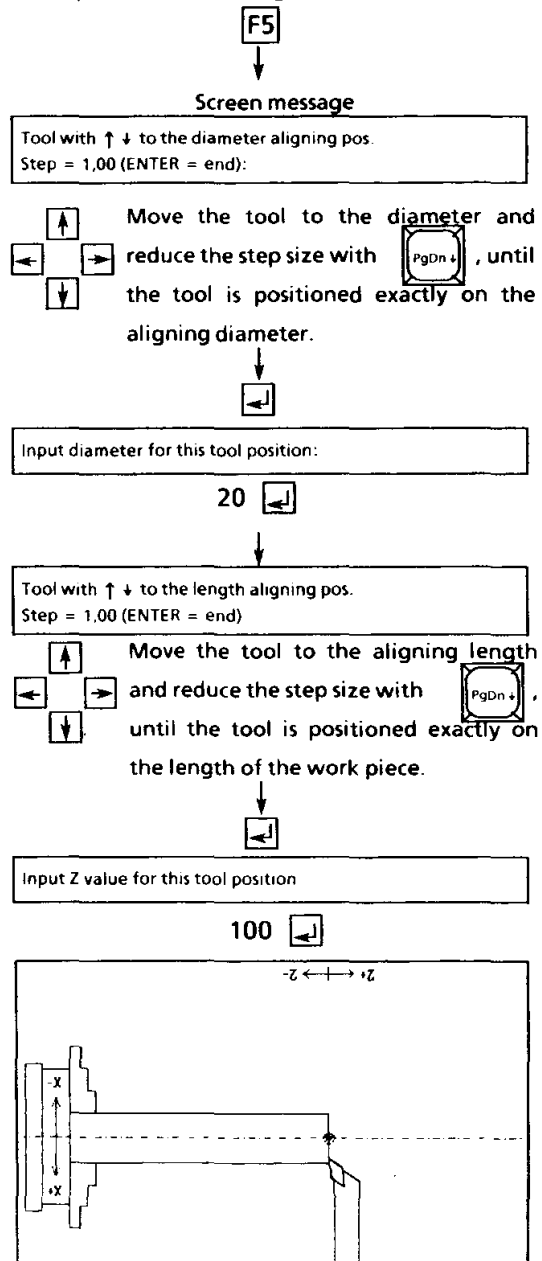



## 4.6 Manual (F6)

Moving the machine in "manual mode". You can move the tool in rapid on the machine and screen at the same time by means of the arrow keys (see hotkeys - machine).

### Condition

The machine was aligning (menu aligning).

### Procedure

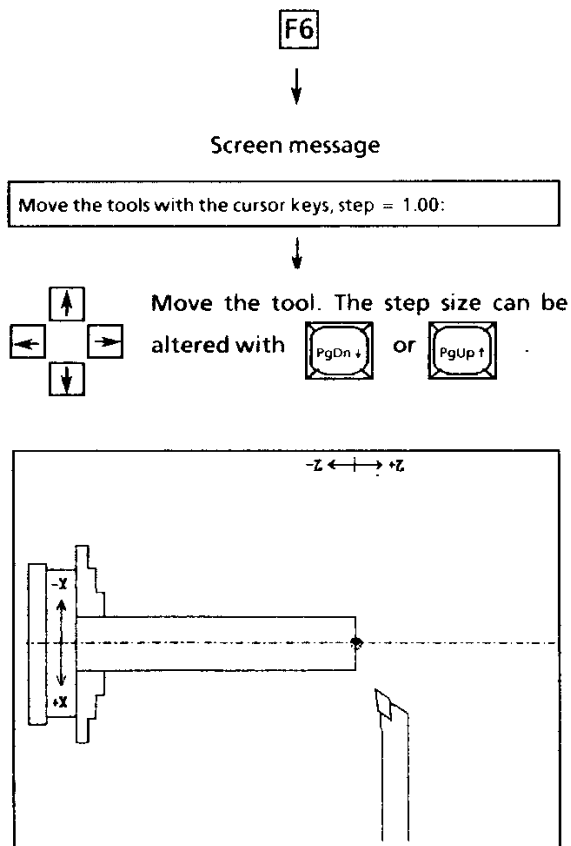

The respective position of the tool is displayed on the screen.

## 4.7 Machine (F7)

Processing the compiled machining program on the machine

### Condition





The machine was aligning (menu aligning).

MACHINE	
F1	AUTOMATIC
F2	SINGLE
F3	FAST RUN
F4	EMPTY CUT
F5	REPEAT
F6	CURSOR
F7	SHIFT PROG
F8	SCALE PROG
F9	
F10	

### 4.7.1 Automatic (F1)

The machining program compiled on the program menu is processed automatically.

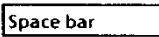
#### Affecting the machining

	.... Increasing the feed
	.... Reducing the feed
	.... Intermediate stop, the slides stop
	.... Interruption of the machining

### 4.7.2 Single (F2)

The machining program is processed in blocks. Every program block must be confirmed with the enter key before the processing.

You exit from this menu point with the Esc. key.

### 4.7.3 Fast run (F3)

The complete machining program is automatically processed in the rapid.

#### Application

Testing a machining program without a work piece

### 4.7.4 Empty cut step (F4)

Move to the desired machining step with the arrow key. The machining program can be started from this block.

#### Procedure









Screen message

Position at desired program steps with + ↑ keys (ENTER = end):

#### Possibilities

	.... Searching block by block from the start of the program
	.... Searching block by block from the end of the program
	.... Return block by block
	.... Forwards block by block
	.... Confirm the desired block

The machining program can be started from this desired block.

(Automatic, single or fast run)

#### Application

Re-machining of certain contour parts

E.g., finishing the fit on a tool with overmeasure. Measure the fit on the clamped tool after the machining.

Move to the fit with "F4 empty cut step".

Process the required differential measure in Single in the X direction with "F7 shift program".

### 4.7.5 Repeating the program (F5)

Unit: [mm]

A machining program can be shifted in the X and Z direction (X = radius dimension) and be repeated. The number of the steps determines how often the machining program is to be shifted and repeated.

#### Application

Finishing several, similar parts from one work piece

#### Procedure

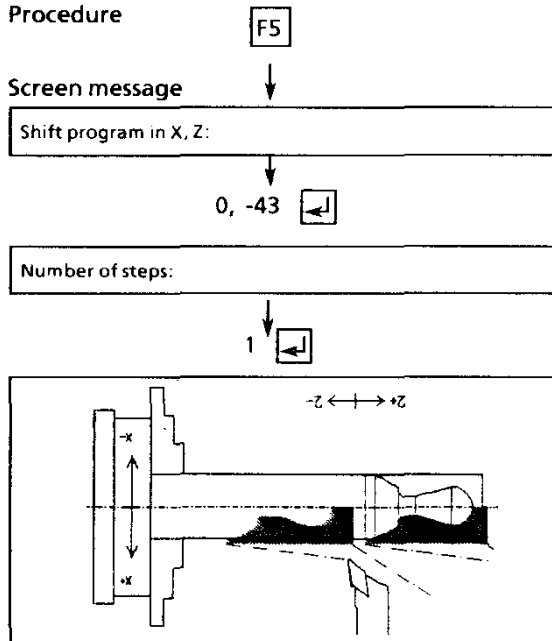

### 4.7.8 Altering the scale program (F8)

A machining program can be enlarged or reduced. The altered scale is assumed as the new scale M1:1 after the enlargement or reduction.

#### Examples:

##### Reduction

Input: 0.5 = M1:2

##### Enlargement

Input: 2 = M2:1

#### Procedure

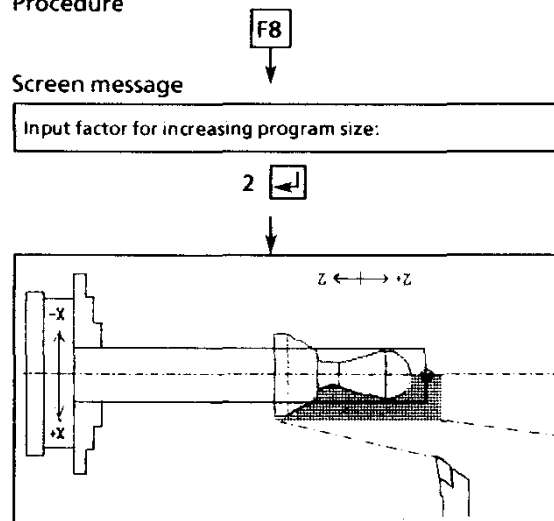

#### Attention!

Observe the size of your work piece, if you alter the machining program in the scale.

### 4.7.6 Moving the tool to the cursor (F6)

The tool is moved from its present position to the cursor position with the set feed, whereby the machine moves along the same movement.

This movement is not copied into the machining program.

### 4.7.7 Shifting the program (F7)

Unit: [mm]

A machining program can be shifted in the X and Z direction (X = radius measurement).

#### Application

Re-turning the work piece contour

## 4.8 Archive (F8)

The programs compiled by you are stored or recalled in this menu.

Drawings created by you or machining programs must be stored as files before leaving the program.

### 4.8.1 Storing the program (PRG) (F1)

Screen message	Entry
	<b>F1</b>
Input file name to be stored:	demo1 

The machining program is stored under the name "demo1".

In the sub directory (e.g. COMPACT) a program is stored in two files:

**DEMO1.GEO**  
**DEMO1.NCP**

**DEMO1** is the name you have chosen (max. 8 signs) and an automatic addition (.GEO resp. NCP).

**.GEO** in this file there are the informations about workpiece, drawing (CAD) and tool path (CAM).

**.NCP** in this file the NC-program is stored.

### 4.8.2 Loading the program (PRG) (F2)

A stored machining program can be recalled.

Example 1: Call-up of a program



Screen message	Entry
	<b>F2</b>
Input file name to be retrieved:	demo1 

The machining program "demo 1" is loaded.

Example 2: Listing all stored programs

All stored programs are displayed in the area menu display, when the sign  is entered.

Screen message	Entry
	<b>F2</b>
Input file name to be retrieved:	* 

The stored programs are displayed and can be selected by means of the   keys and recalled with .

### 4.8.3 Storing the geometry (GEO) (F3)

A work piece drawing can be stored.

Screen message	Entry
	<b>F3</b>
Input file name to be stored:	part 1 <input type="text"/>

The work piece drawing is stored under the name "part 1".

The work piece geometries ( are stored under the name entered by you in your sub-directory (e.g.: COMPACT) and are automatically provided with the suffix .DXF.

The suffix .DXF means that the work piece geometries are stored in the DXF format. I.e.: you can read AUTOCAD drawings in the DXF format into this software or work piece geometries created with this software can be copied into the AUTOCAD software.

### 4.8.4 Loading the geometry (GEO) (F4)

A stored work piece drawing can be recalled.

Screen message	Entry
	<b>F4</b>
Input file name to be retrieved:	part1 <input type="text"/>

The work piece drawing "part1" is loaded.

Listing all stored work piece drawings works as with programs (chapter 4.8.2).

#### Erasing the stored programs and geometries

- Exit the software (remain in the sub-directory COMPACT).
- All files in the sub-directory COMPACT are listed by means of the DOS command "DIR".
- Erasing the respective file (see DOS manual).

### 4.9 Print (F9)

The respective screen display is printed.

#### Condition

The printer is connected, switched on and set in the IBM graphics mode (see printer manual).

Screen message	Entry
	<b>F9</b>
Is the printer connected and on "line"? (ENTER = yes)	<input type="text"/>

#### Possibilities

ENTER = printing

Any other key = interruption

### 4.10 End (F10)

Exit from the program

#### Attention!

You must store the programs compiled by you beforehand (archive menu).

Screen message	Entry
	<b>F10</b>
Are you sure? (ENTER = yes):	<input type="text"/>

#### Possibilities

ENTER = exit from the program

Any other key = remaining in the program

The title screen appears again:

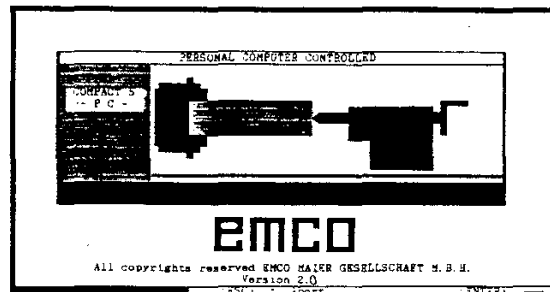

... Return to DOS



# 5. SPECIMEN EXAMPLES

## Chess figures

These specimen examples serve to re-inforce the knowledge acquired concerning the programming of this EMCO software.

The creation of the contour of these examples is explained step by step on the following pages.

We recommend you to use aluminium and brass with a diameter of 20 and a length of 50-70 mm for the chess figures due to chip removal reasons.

You will find the technological data, like

- max. main spindle speeds
- max. feed
- max. cutting depths

in chapter A "machine description".

The figures are designed in such a way that the back-off cycles can be worked off with the right lateral steel.

When preparing the program it is advantageous to execute the roughing cycle at the extreme right as last processing cycle. Thus workpieces can be supported with the lathe center until the last working cycle.

The lathe center has to be removed in time in the last working cycle to avoid a collision with the tool.

### Pawn

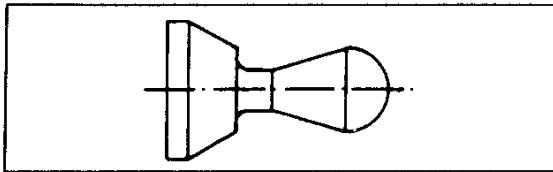

**1. Creating a work piece**

(See work piece (F1))

Ø = 20 mm, length = 52 mm, center hole = 4,5

Drawing aid

The work piece is enlarged across the whole of the screen surface by means of the hotkey **Z**.

**2. Drawing the work piece contour**

(See submenu point, line/hotkeys)

Note

Only the lower half of the work piece contour must be drawn.

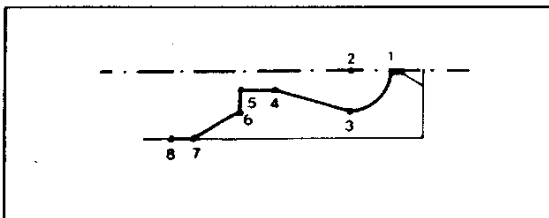

Contour points	X direction	Z direction
1	0	-5
2	0	-11
3	6	-11
4	3	-22
5	3	-27
6	6	-27
7	10	-34
8	10	-37

**3. Adding the radii and chamfers**

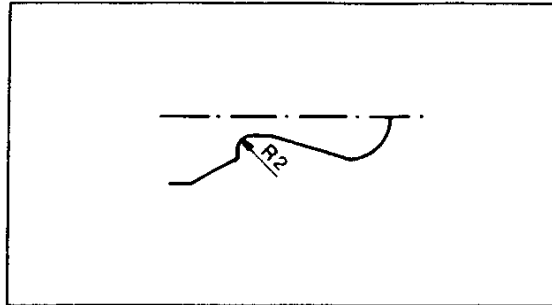

**4. Cleaning**

**5. Splitting the arc (F4)**

**6. Adding the visible edges (F5)**

**7. Mirroring the work piece contour (F6)**

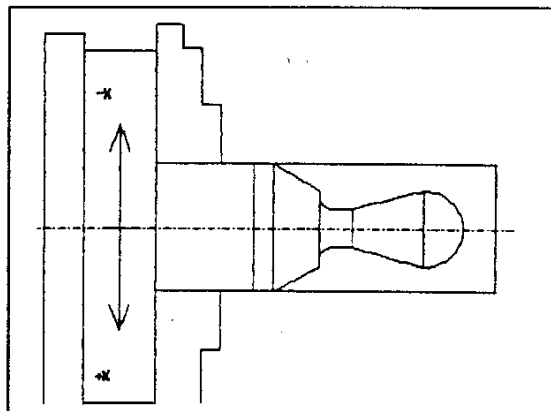

**8. Storing the work piece contour**

(See ARCHIVE (F8))





### Bishop

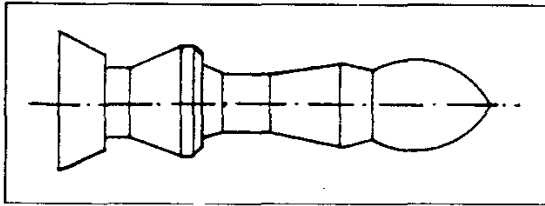

#### 1. Creating a work piece

(See work piece (F1))

Ø = 20 mm, length = 85 mm, center hole = 4,5

Drawing aid

The work piece is enlarged across the whole of the screen surface by means of the hotkey **[Z]**.

#### 2. Drawing the work piece contour

(See submenu point, line/hotkeys)

Note

Only the lower half of the work piece contour must be drawn.

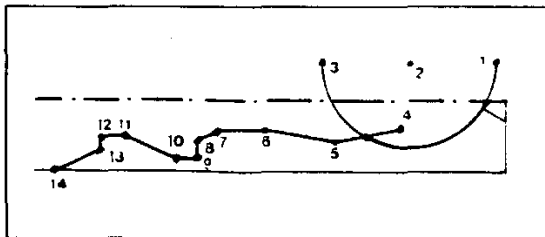

Contour points	X direction	Z direction
1	-5	-1
2	-5	-13,5
3	-5	-26
4	4	-15
5	6	-25
6	4	-35
7	4	-42
8	6	-45
9	8	-45
10	8	-48
11	5	-55
12	5	-59
13	7	-59
14	10	-65

#### 3. Cleaning

#### 4. Adding the radii and chamfers

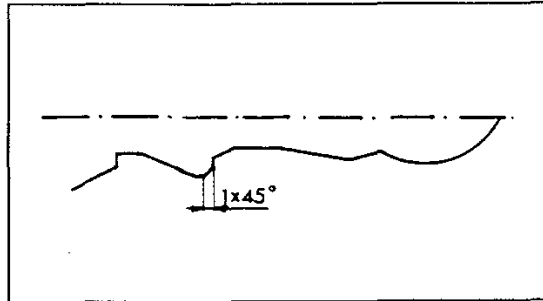

#### 5. Splitting the arc (F4)

#### 6. Adding the visible edges (F5)

#### 7. Mirroring the work piece contour (F6)

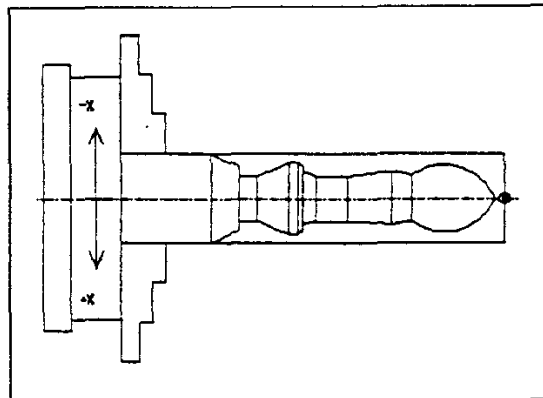

#### 8. Storing the work piece contour

(See ARCHIVE (F8))



Queen

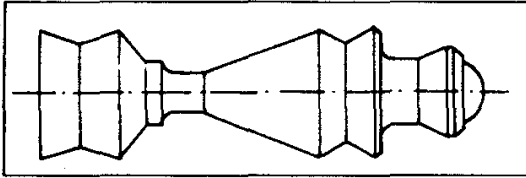

1. Creating a work piece

(See work piece (F1))

$\varnothing = 20$  mm, length = 87 mm, center hole = 4,5

Drawing aid

The work piece is enlarged across the whole of the screen surface by means of the hotkey **[Z]**.

2. Drawing the work piece contour

(See submenu point, line/hotkeys)

Note

Only the lower half of the work piece contour must be drawn.

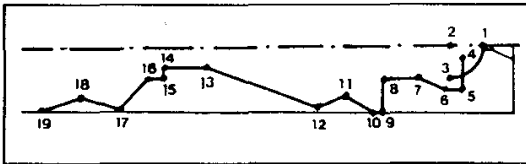

Contour points	X direction	Z direction
1	0	-5
2	0	-10
3	5	-10
4	2	-8
5	7	-8
6	7	-10
7	5	-15
8	5	-20
9	10	-20
10	10	-22
11	8	-25
12	10	-30
13	3	-47
14	3	-53
15	5	-53
16	5	-55
17	10	-60
18	8	-66
19	10	-72

3. Cleaning

4. Adding the radii and chamfers

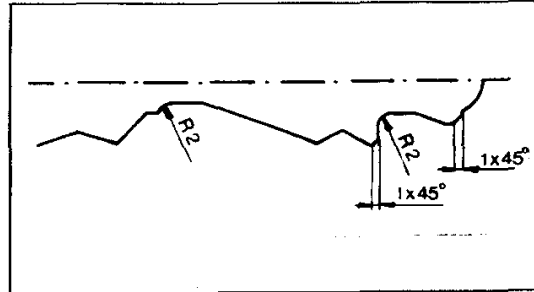

5. Adding the visible edges (F5)

6. Mirroring the work piece contour (F6)

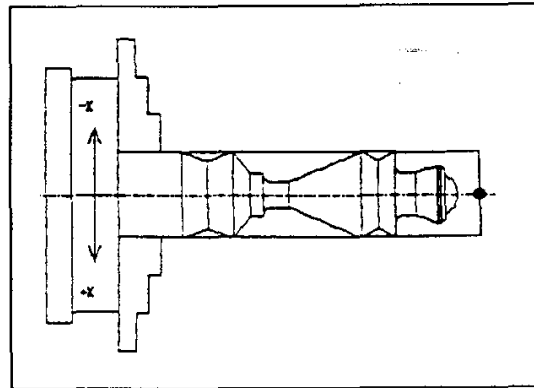

7. Storing the work piece contour

(See ARCHIVE (F8))

King

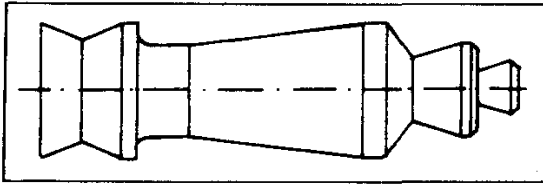

1. Creating a work piece

(See work piece (F1))

$\varnothing = 20$  mm, length = 90 mm, center hole = 4,5

Drawing aid

The work piece is enlarged across the whole of the screen surface by means of the hotkey **Z**.

2. Drawing the work piece contour

(See submenu point, line/hotkeys)

Note

Only the lower half of the work piece contour must be drawn.

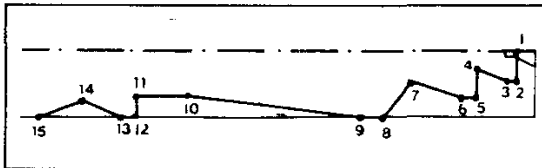

Contour points	X direction	Z direction
1	0	-3
2	4,5	-3
3	4,5	-4,5
4	3	-8
5	7	-8
6	7	-10
7	5	-18
8	10	-22
9	10	-25
10	7	-50
11	7	-58
12	10	-58
13	10	-60
14	8	-66
15	10	-72

3. Adding the radii and chamfers

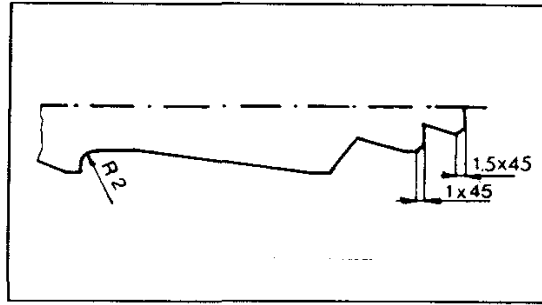

4. Adding the visible edges (F5)

5. Mirroring the work piece contour (F6)

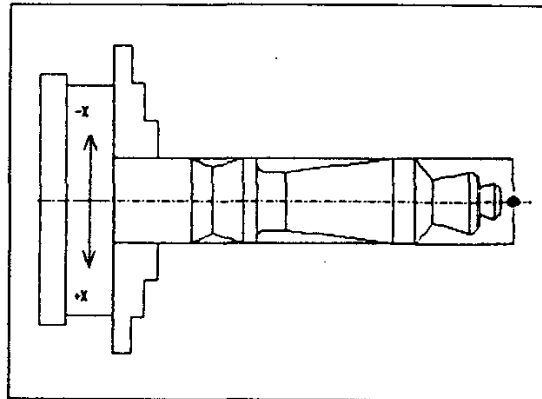

6. Storing the work piece contour

(See ARCHIVE (F8))

Rook

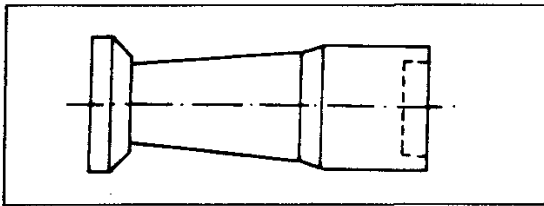

1. Creating a work piece

(See page work piece (F1))

Ø = 20 mm, length = 65 mm, center hole 8.5, 5

Drawing aid

The work piece is enlarged across the whole of the screen surface by means of the hotkey **Z**.

2. Drawing the work piece contour

(See submenu point, line/hotkeys)

Note

Only the lower half of the work piece contour must be drawn.

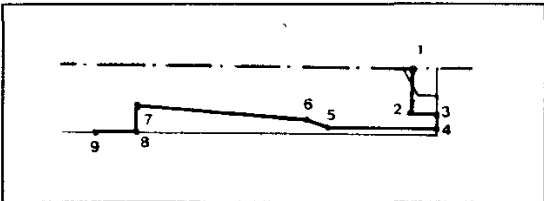

Contour points	X direction	Z direction
1	0	-4
2	7	-4
3	7	0
4	9	0
5	9	-16
6	8	-19
7	6	-44
8	10	-44
9	10	-50

3. Adding the radii and chamfers

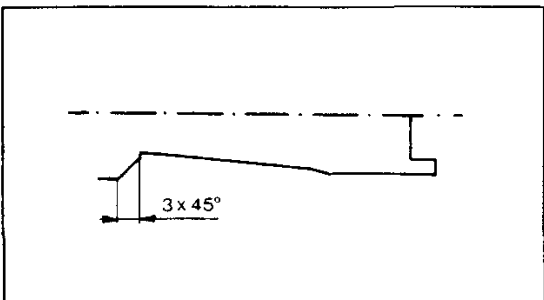

4. Adding the visible edges (F5)

5. Mirroring the work piece contour (F6)

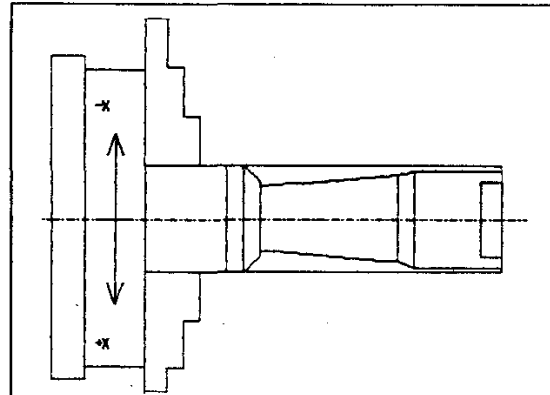

6. Storing the work piece contour

(See ARCHIVE (F8))

Note on inside turning

- Since inside turning is carried out in over-mounted form (without center punch support), feed (F) and advance should be as small as possible.

F = approx. 20 mm/min

Advance approx. 0,2 mm

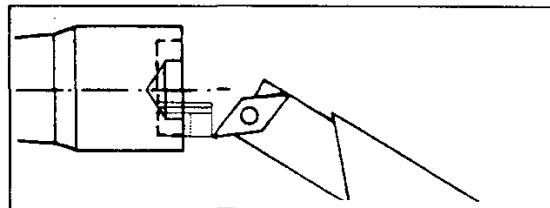

- For inside turning of small diameters the inside cutting tool has to be set obliquely to avoid collisions (A). However, mind in any case that a clearance angle remains behind the tool tip to guarantee a perfect cut.

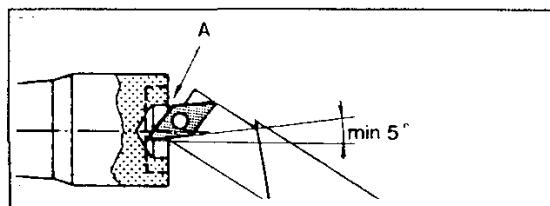

### Knight

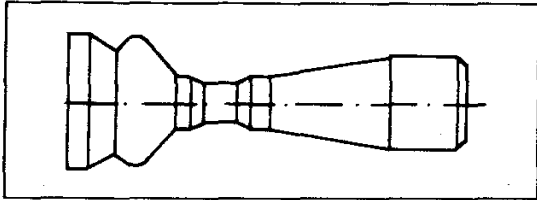

**1. Creating a work piece**

(See work piece (F1))

Ø = 20 mm, length = 80 mm, center hole = 4,5

Drawing aid

The work piece is enlarged across the whole of the screen surface by means of the hotkey **Z**.

**2. Drawing the work piece contour**

(See submenu point, line/hotkeys)

Note

Only the lower half of the work piece contour must be drawn.

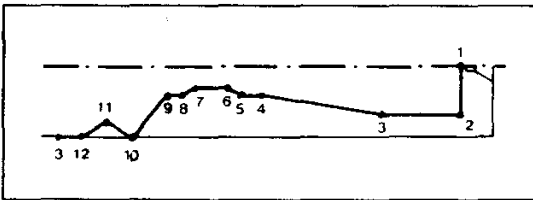

Contour points	X direction	Z direction
1	0	-5
2	7	-5
3	7	-17
4	4	-35
5	4	-38
6	3	-40
7	3	-45
8	4	-47
9	4	-49
10	10	-54
11	8	-58
12	10	-62
13	10	-65

**3. Adding the radii and chamfers**

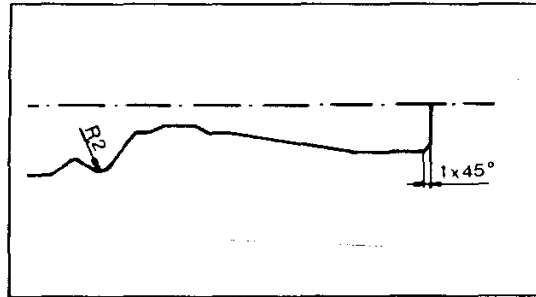

**4. Adding the visible edges (F5)**

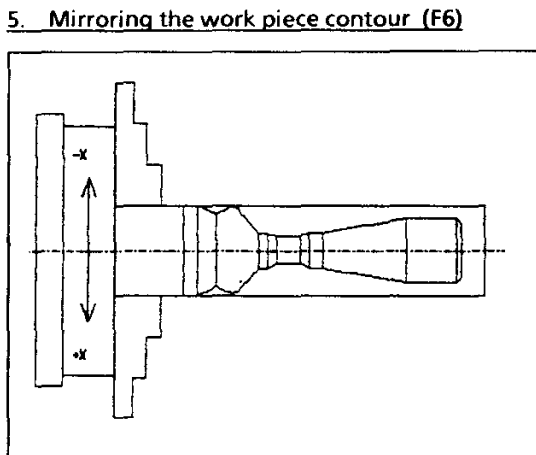

**6. Storing the work piece contour**

(See ARCHIVE (F8))

### Extension for the knight

Working with the vertical equipment

Tool: roughing mill Ø 8 mm

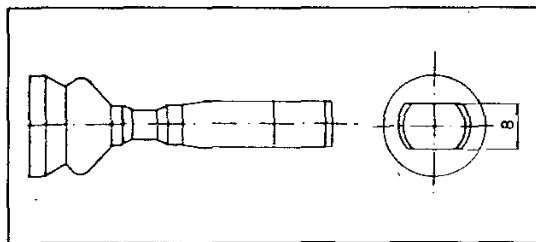





## 6. EDIT

### Introduction

With the COMPACT 5 PC software you have not only an efficient CAD/CAM software, but you can also work like at a normal CNC machine and set up standard (DIN 66025 and ISO 1056) NC programs.

#### Explanation of term EDIT

The procedure of entering data (numbers and letters) into a PC or in a control is also called edit.

#### Example:

An NC program is entered into the computer (edited). This is carried out in a certain part of the COMPACT 5 PC software, the EDIT.

EDIT = mode for program input

#### What is programming

Programming = communicating data in a settled sequence and language which the computer can understand and transform. The NC-programming language and the NC-program structure was determined by experts in DIN 66025 and ISO 1056.

#### Setting up an NC-program

When you are setting up an NC-program you have to give exactly the same information and instructions to the computer as are needed by someone for machining a workpiece on a hand-operating machine who has no idea of turning.

This information is:

1. Geometrical data  
You find these geometrical data (dimensions) on the drawing of the workpiece.
2. Technological data  
Feed, spindle speeds, tools, etc.
3. Machine functions  
These are described in this chapter (see G, M-functions)
4. Program instructions  
When setting up an NC program certain instructions on sequences of commands (see G, M-functions) have to be adhered to.

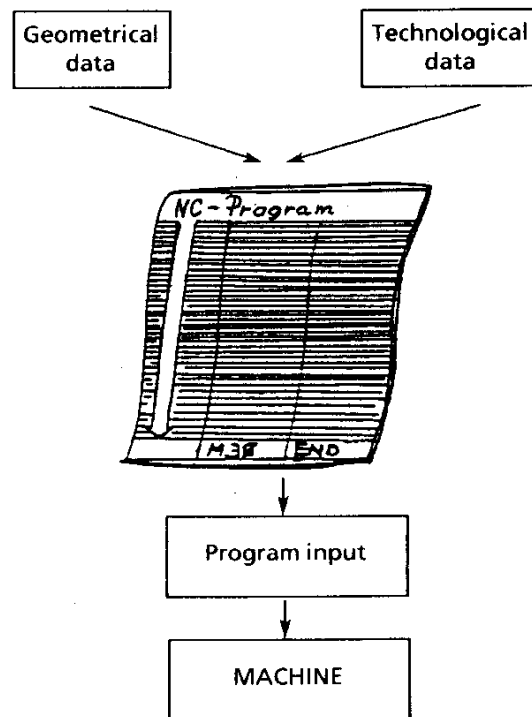



# Geometrical Data

## Coordinate system

The information "move longitudinal slide in direction headstock" is a very long one. Besides that, in each language it would be different. That's why the traverse path movements with machine tools are described within the coordinate system.

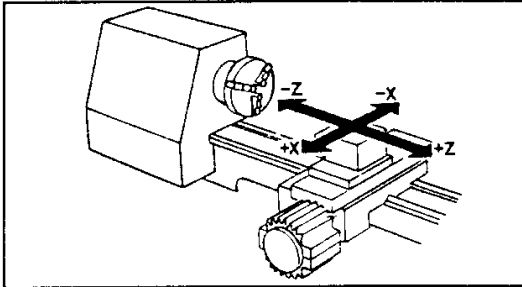

## Lettering of drawing

The geometrical information is in the technical drawing. Drawings can be done according to the incremental or to the absolute system. In many cases you find a combination of these two systems: incremental and absolute.

### Absolute system

There is one point of reference.

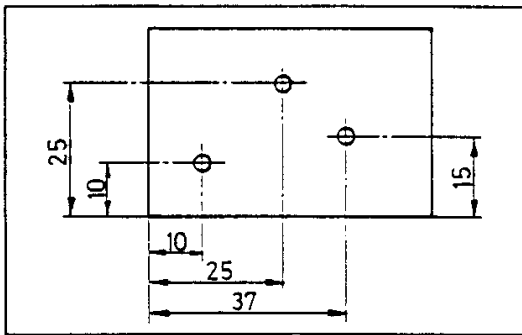

### Incremental system

Each measurement is based on the previous one.

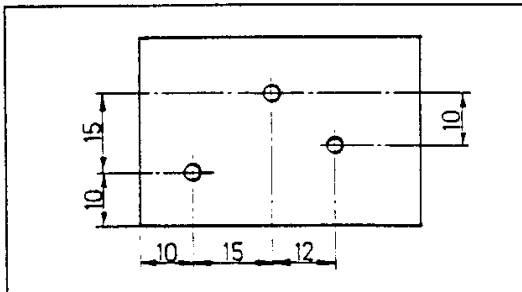

### Combined system

The measurements 1 and 2 are absolute ones, i.e. based on one point of reference. The measurements 3 and 4 are incremental ones.

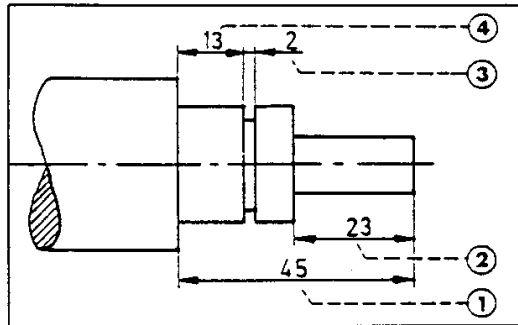

## Methods of programming

In the program you have describe in each block the path of the turning tool. Basically there are two methods to describe this path.

### 1. Absolute value programming:

The points which the turning tool has to approach are indicated by a zero point with X and Z. The X value is a diameter value.

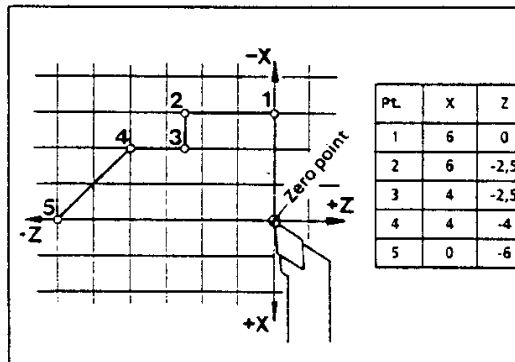

### 2. Incremental dimension programming:

Here the incremental dimensions are entered with U and W. The initial point for each path description is the actual position of the turning tool. The U value is a radius value.

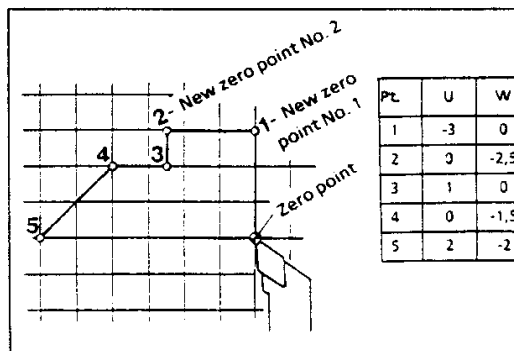

## The zero point of the workpiece = reference point

The reference point (R) is on the Z axis at the right blank edge.

### Attention:

A new blank has to be set up before editing an NC-program.

### Reason:

Otherwise all the values entered into the NC program do not refer to the reference point (R) but to the machine zero point (M).

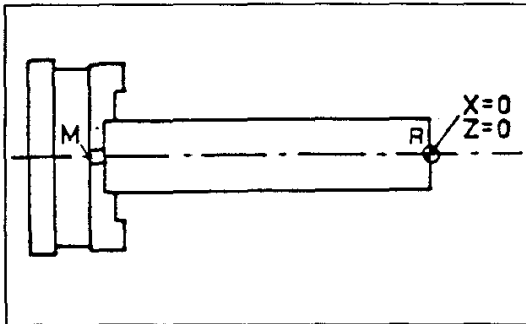

## Technological Data

### The feed (F)

The feed can be programmed in mm/min or in mic/r ( $=\mu\text{m}/r$ ). For further information see chapter G94/G95.

### Tool programming (T)

The call-up of tools and the tool change are programmed with the letter T and a two-digit number

e.g. T01

The T is the abbreviation of the English word "Tool".

The two-digit number indicates the tool number.

#### Tool number:

T01	right side tool
T02	neutral side tool
T03	left side tool
T04	parting-off tool
T05	cut-in tool for locking rings
T06	left thread-cutting tool
T07	right thread-cutting tool
T08	inside boring tool
T09	inside cut-in tool for locking rings
T10	right inside thread-cutting tool
T11	left inside thread-cutting tool
T12	not occupied

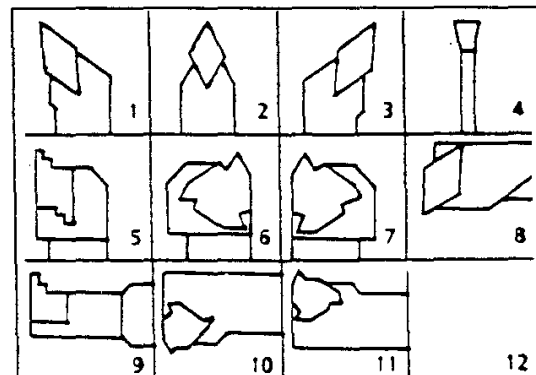

#### Note

A G00 (rapid motion) has to be programmed as next travel motion after each new tool call-up.

Possibility 1: in the same block  
N .../T02/G00/X .../Z ...

Possibility 2: in the next block  
N .../T02  
N .../G00/X .../Z ...

## Program Structure

### Parts of the NC program

#### 1. The program

All essential data for the manufacture of a work piece are filled in.

The structure of such a program is standardized.

```
N0000/G67/F3
N0010/G94/F150/T01
N0020/G00/X25/Z2
N0030/G01/X21/Z1/F100
N0040/G84/X16/Z-10/D3=500/F100
N0050/G00/X35/Z10
N0060/G56
N0070/M30
```

#### 2. The block

The program consists of blocks. A block contains all data necessary to execute an operation.

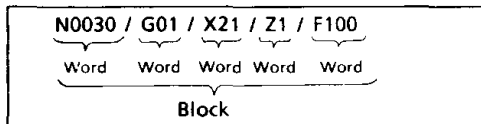

#### 3. The word

Each block consists of various words. Each word has a special meaning.

A word consists of a letter and a combination of numbers. The letter is called address.

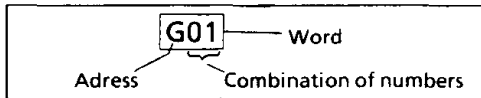

### The words of the Compact 5 PC

#### N:

N indicates the block number. Practicable block numbers are N0000 up to N9999. It is appropriate to number the program blocks in steps of tens.

#### G:

G is a symbol for the path information. Each figure is allocated to a certain kind of motion. e.g. 01 = move in straight line 03 move in circle, etc.

#### X:

X means indication of the absolute position of the X axis. The numerical value may have the operational sign "+" or "-" (X = diameter value).

Input: mm

#### Z:

Z means absolute indication of the position of the Z axis. The numerical value may have the operational sign "+" or "-".

Input: mm

#### U:

U means incremental indication of the position of the X axis. The numerical value may have the operational sign "+" or "-" (U = radius value).

Input: mm

#### W:

W means incremental indication of the position of the Z axis. The numerical value may have the operational sign "+" or "-".

Input: mm

Note: The addresses X, Z, U, W can also be programmed mixed in one block.

#### I:

I means an incremental path indication in direction X with circle movements (G02/G03). I is an auxiliary indication for the calculation of the circular traverse motion. The numerical value may have the operational sign "+" or "-".

Input: mm

#### K:

K means an incremental path indication in direction Z at with circle movements (G02/G03). K is an auxiliary indication for the calculation of the circular traverse motion. The numerical value may have the operational sign "+" or "-".

Input: mm

#### F:

Under the F address different information can be programmed:

1. F in connection with G94:  
Under the F-address the feed is programmed in mm/min.
2. F in connection with G95:  
Under the F-address the feed is programmed in  $\mu\text{m}/\text{min}$ .
3. F in connection with G85:  
Under the F-address the thread pitch is programmed in  $\mu\text{m}/\text{min}$ .
4. F in connection with G67:  
Under the F-address the colour of the tool path is determined (for graphic simulation).

#### T:

With T a certain tool can be called up. Possible tool addresses are T01 up to T11.

#### M:

M is the abbreviation of the English word "miscellaneous". Switching and additional functions are determined with M.

Note: On the Compact 5 PC only M30-program end can be programmed.

On industrial machines functions such as e.g. "COOLANT ON/OFF", "CLAMPING DEVICE OPEN/CLOSE" are programmed with M-functions.



## The parameters of the Compact 5 PC

With the parameters P and D additional information for working off the cycles (G84, G85, G86) are communicated to the PC.

e.g. with G84 a cone can be programmed with  $P_0$  in  $\pm X$  direction.

The D-parameters must be entered in each case. The P-parameters have to be programmed only if the value is not 0.

## Survey of G and M functions

G00	Rapid motion
G01	Feed motion (straight line interpolation)
G02	Circle interpolation in clockwise direction
G03	Circle interpolation in counterclockwise direction
G56	Deselection of reference point offset
G59	Call-up of reference point offset
G67	Indicate colour of tool path
G84	Longitudinal turning and facing cycle
G85	Thread cycle
G86	Cut-in cycle
G92	Reference point offset
G94	Feed speed in mm/min
G95	Feed speed in $\mu\text{m/r}$
M30	Program end

## Specifications on the sequence of words:

Apart from the X(U), Z(W) sequence in the cycle G84 there is no absolute rule on the word sequence. However, so as to obtain a clear program structure, you should observe the following sequence:

- \* Each block starts with the block number N.
- \* The G-function should be programmed after the block number.
- \* Words for the coordinates X(U), Z(W). Observe the reversal of the X(U), Z(W) sequence in the cycle G84.
- \* Where G02, G03 is programmed, the interpolation parameter I, K should be programmed after X(U), Z(W).
- \* Where cycles are programmed, the parameters should be programmed after the X(U), Z(W) addresses.
- \* The F-word (feed thread pitch).
- \* The T-word (tool address).
- \* The M-word (additional functions).

## Self-holding functions, words

- \* G and M functions and also other words are self-holding. That means that they are active until they are overwritten or selected.

Example:  
 N100/...  
 N110/G00/X50.000/Z20.000  
 N120/X40.000/Z18.000  
 N130/G01/X30.000/Z15.000/F100  
 N140/...

Explanation:  
 G00 is also effective in block 120 and is overwritten with G01 in block 130.

- \* X(U), Z(W), F, T word contents are taken over in the following blocks:

Example:  
 N200/...  
 N210/G01/X40.000/Z25.000/F120  
 N220/Z12.000  
 N230/G00/X35.000/Z32.000  
 N240/...

Explanation:  
 In block 220 G01, X = 40 and F120 is effective. F120 remains effective until another value is programmed under the F address.

## G-Codes, their formats and description of formats

Specific addresses are assigned to most G-codes.

### Example:

G00/X ± ...../Z ± .....

or

G01/X ± ...../Z ± ...../F....

For a short and easy to understand description of pertaining addresses (format description) the data are encoded.

### Code:

- 1) Instead of giving the possible inputs, the number of decades is given.

### Example:

Instead: N from 0 to 9999  
or N.... we write N4.

$N_{\begin{matrix} \dots \\ 4 \end{matrix}} \rightarrow N4$

- 2) The specification of the possible decades before or after a decimal point is coded with two figures.

$X_{\begin{matrix} \dots \dots \\ 4 \quad 3 \end{matrix}} \rightarrow X43$

The first figure: Decade before decimal point

The second figure: Decade after decimal point

- 3) If the values could be negative or positive a + sign is written between address and number.

X + 43

**Remark:** For better determination quite often a ± sign is written (X ± 43). Underneath the input format there are the different dimensions shown.

### Example:

N4	G01	X U	±43	Z W	±43	F4
			(mm)		(mm)	(µm/r)
						(mm/min)

N4: four digits without decimal point and sign

X, Z, U, W: ± sign possible, four digits before decimal point, three digits after decimal point

F4: four digits without decimal point and sign

## Guidelines for working in EDIT

On the following pages you can find the description of the functions with which you are able to set up NC programs.

The G functions are arranged in rising order (G00 up to G95). If you are learning this kind of programming you should mind the following:

### 1. Guideline for program start and program end:

Program start:

G67/F → determine colour of tool path

G94(G95) → feed in mm/min or µm/r

F → feed programming

T → tool programming

G00 → rapid motion

After each tool call-up the 1<sup>st</sup> traverse movement must be a G00 block.

Program end:

M30 means end of program. M30 don't have to be programmed at this software.

### 2. Sequence for beginners for learning how to program:

G67 determine colour of the tool path

T tool programming

F feed programming

G94/G95 feed in µm/r, mm/min

G00 rapid motion

G01 feed movement

G84 longitudinal turning cycle

G84 facing cycle

G86 cut-in cycle

G85 threading cycle

G02/G03 circular interpolation

G92/G59 offset position

G56

Also study all the exercises for the individual G-functions. These are set up in such a way that you are introduced to programming step by step.

For the G-functions there is a specific summary. This is framed in grey and serves also as a short description.



## G00 - Rapid motion

Input format:

N 4	G00	X ± 43	Z ± 43
		U	W
		[mm]	[mm]

N ..... Block number  
 G00 .. Rapid motion  
 X(U) } Absolute (incremental) coordinates  
 Z(W) } of the target point Z

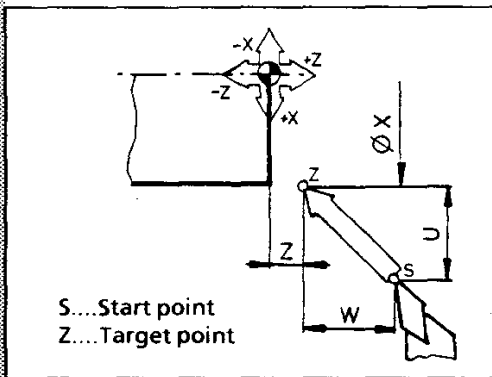

The positioning of the turning tools, i.e. movement of same without chip removal, must be done with highest possible speeds (rapid motion) for economic reasons. The slides move simultaneously in X and Z direction.

**Rapid motion speed:** PC/AT: 700 mm/min  
 PC/XT: 350 mm/min

G00 (rapid motion) is merely a traversing movement - no working movement!

**Notes:**

- It does not matter in which sequence X (U), Z (W) are written.
- They can also be programmed mixed in one block (absolute and incremental).  
 e.g.: G00/X44.000/W-9.000

**Example:**

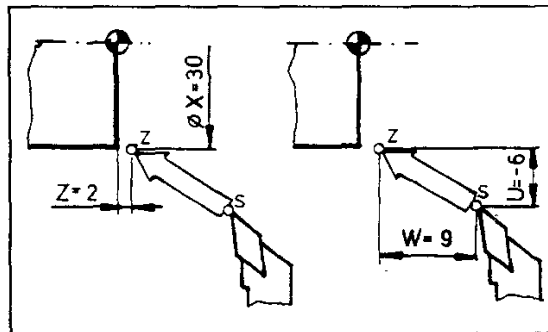

absolute: N.../G00/X30/Z2  
 incremental: N.../G00/U-6/W-9

## G01 - Straight line interpolation

**Input format:**

N 4	<b>G01</b>	Z ±43	F 4
		[mm]	[μm/r] [mm/min]

N ..... Block number  
 G01 ... Straight line interpolation  
 X(U) } Absolute (incremental) coordinates of the target point Z  
 Z(W) }  
 F ..... Feed

G01 is a linear operating movement. The feed must be programmed. It can be input in [mm/min] (G94) or in [μm/r] (G95). The feed (F) is self-holding.  
 X = diameter value  
 U = radius value

Possibilities of G01:

**1. Turning in Z direction (longitudinal turning)**  
 Longitudinal turning with defined feed speed. The X movement is zero. No value is entered for X (U).

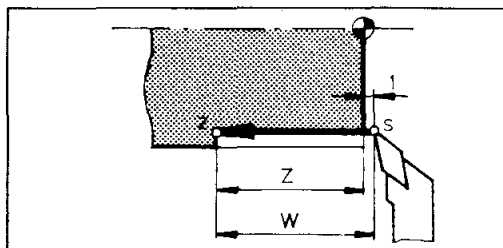

N.../G01/-Z (-W)/F...

**2. Turning in direction X (facing)**

Facing with defined feed speed.

The Z movement is zero. No value is entered for Z(W).

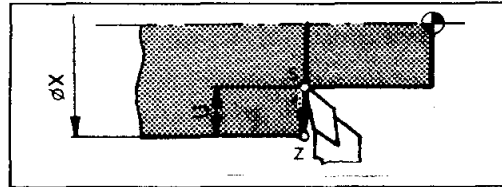

N.../G01/X(U)/F...

**3. Turning in X and Z direction (taper turning)**

With taper turning longitudinal and lateral slides must move simultaneously. In accordance with the taper angle the slides have to traverse at a certain ratio. The computer (PC) calculates a lot of intermediate values referring to this straight line and transmits the respective traverse commands to the slides.

This finding of intermediate values of a straight line is called straight line interpolation.

The straight line can have any angular position.

With longitudinal turning and facing no interpolation takes place.

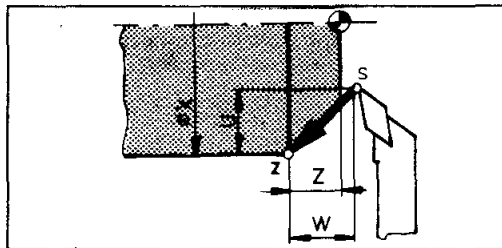

Example:

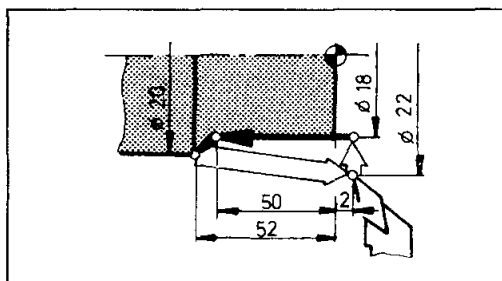

absolute:

- N100/.....
- N110/G00/X22/Z2
- N120/G00/X18
- N130/G01/Z-50/F...
- N140/G01/X20/Z-52/F...
- N150/G00/X22/Z2
- N160/.....

incremental:

- N100/.....
- N110/G00/.....
- N120/G00/U-2 (Radius!)
- N130/G01/W-52/F...
- N140/G01/U1/W-2/F...
- N150/G00/U1/W54
- N160/.....

## G02/G03 - Arc interpolation

Block format:

N 4	<b>G02</b>	X $\pm 43$	Z $\pm 43$	I $\pm 43$	K $\pm 43$	F 4
	<b>G03</b>	U $\pm 43$	W $\pm 43$			
		[mm]	[mm]	[mm]	[mm]	[ $\mu\text{m}/\text{r}$ ]
						[mm, in]

- N ..... Block number
- G02... Arc interpolation clockwise
- G03... Arc interpolation counter-clockwise
- X (U) } Absolute (incremental) coordinates of the target point
- Z (W) }
- I, K .... Arc centre point coordinates
- F..... Feed

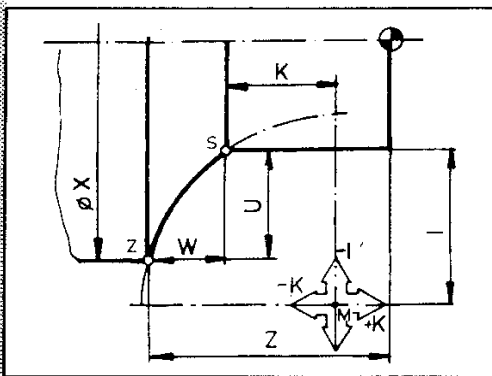

### 1. General

- With circle turning longitudinal and lateral slide must move at the same time. In contrast to the straight line interpolation the ratio X:Z is changing continuously. The computer (PC) calculates a lot of intermediate values referring to the circular arc and transmits the respective traversing commands to the slides. This finding of intermediate values of a circle is called circle interpolation.
- In one block, arcs up to a maximum of 180° can be programmed.

### 2. G02/G03

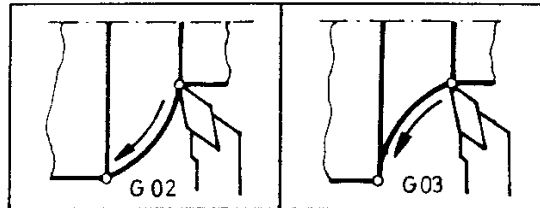

Rotation G02 clock-wise

Rotation G03 counter-clockwise

### 3. Target point coordinates X,Z/U,W

With X,Z the target point (Z) of the circular arc is described (absolute) from the reference point (R). X is a diameter value.

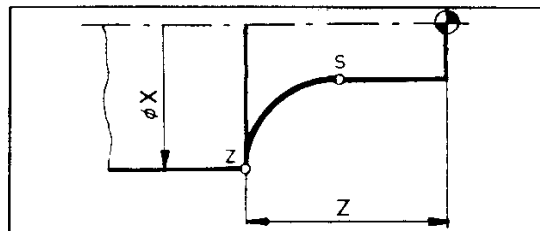

With U, W the target point (Z) of the circular arc is described from the starting point (S) (incremental). U is a radius value.

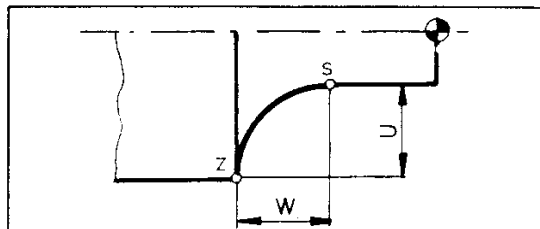



4. Coordinates of the center of the circle I,K

The computer knows the starting point (S) and the target point (Z) but not yet the value of the radius. Therefore the coordinates of the center of the circle are described (I,K).

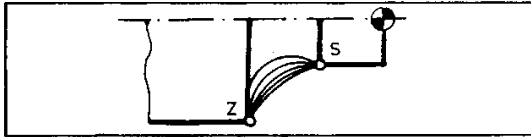

Imagine the I, K system of coordinates in the center of the circular arc and describe from there the starting point of the circular arc.

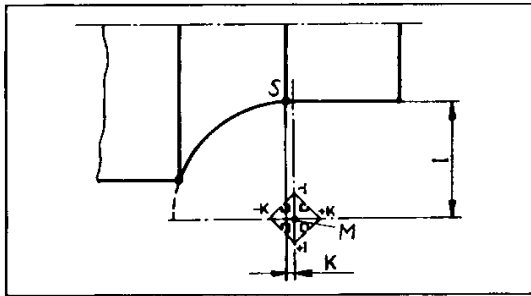

The coordinates I, K are programmed always incremental.

Example 1

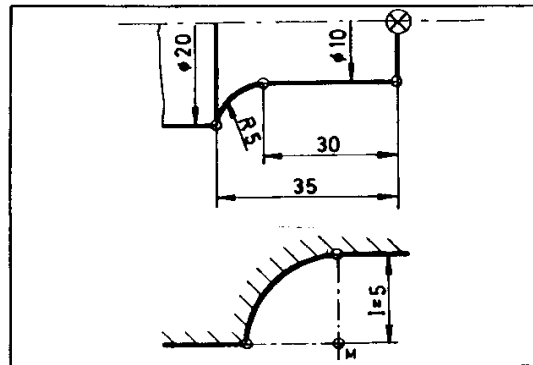

absolute: N.../G03/X20/Z-35/I -5/K 0 /F...  
 incremental: N.../G03/U5/W-5/I -5/K 0/F...

Example 2

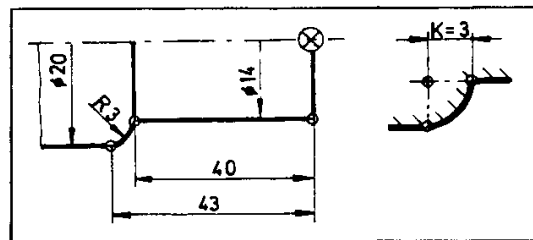

absolute: N.../G02/X20/Z-43/I 0/K 3/F...  
 incremental: N.../G02/U3/W-3/I 0/K 3/F...

Example 3

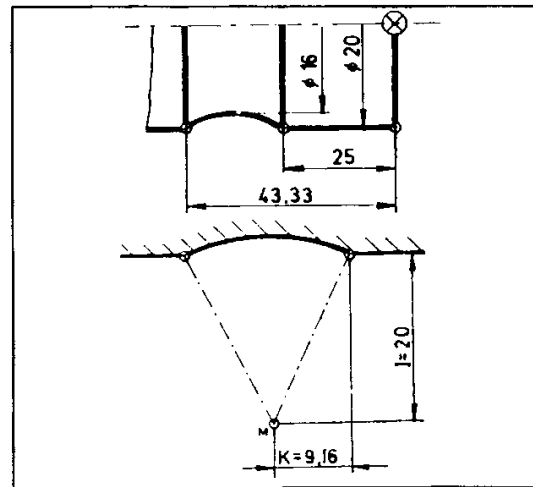

absolute: N.../G03/Z-43.33/I -20/K 9.16/F...  
 incremental: N.../G03/W-18.33/I -20/K 9.16/F...

### G56 Deactivation of the reference point offset

Input format:

N4	G56
----	-----

Explanation see G92 "The reference point".

### G67 Colour of the tool path

Input format:

N4	G67	F2
----	-----	----

F... Colour code see table

For the simulation of your NC-program it is possible to change the colour of the tool path with G67.

The block with G67 has to be programmed before that block which describes the tool path. G67 is self-holding and can be used in the program as often you want.

When using a black-and-white screen (Herkules board) the function G67 is of no significance.

### G59 Activation of the reference point offset

Input format:

N4	G59
----	-----

Explanation see G92 "The reference point".

Series 1: dark	Series 2: clear
F0 black	F8 dark grey
F1 dark blue	F9 light blue
F2 dark green	F10 light green
F3 turquoise	F11 light blue
F4 dark red	F12 light red
F5 lilac	F13 violet
F6 orange	F14 yellow
F7 grey	F15 white

The colours can be a little different on each screen.

Example:

```

N.... G67/F6
N.... G00/X.. ← orange tool path
N.... G67/F14
N.... G84/X../Z.. }
      : :           } yellow tool path
    
```



## G84 - Longitudinal turning cycle

Input format:

N 4	<b>G84</b>	X ± 43	Z ± 43	P <sub>0</sub> ± 43	D <sub>3</sub> 5	F 4
		U	W	P <sub>2</sub>		
		(mm)	(mm)	(mm)	(μm)	(μm/r)
						(mm/min)

- N ..... Block number
- G84 .. Longitudinal turning cycle
- X(U) } Absolute (incremental) coordinates
- Z(W) } of the contour corner point
- P<sub>0</sub> ..... Taper dimension in X (radius value)
- P<sub>2</sub> ..... Taper dimension in Z
- D<sub>3</sub> ..... Cut division
- F ..... Feed

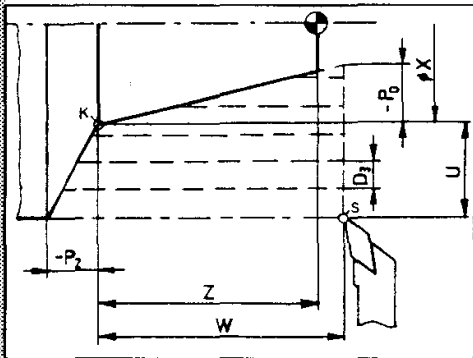

If there is no P<sub>0</sub> or P<sub>2</sub>, it need not be programmed.

### Cycle definition

A cycle is a movement sequence of the tool which consists of a series of individual movements.

- G00 Movement with rapid motion
- G01 Movement with programmed feed speed (F) in mm/min or μm/r.

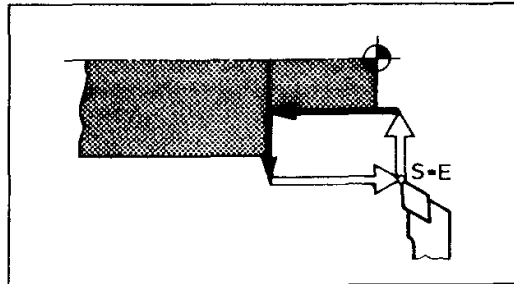

A cycle always has a closed movement sequence: starting point (S) = final point (E)  
The starting point (S) is approached in the block before G84.

### Contour corner point (K)

The movement sequence of a cycle is defined by starting point (S) and contour corner point (K). In accordance with the position of S and K to each other there are four kinds of cycle that you get as a result.

K is described with X,Z absolute or with U,W starting from S (incremental).

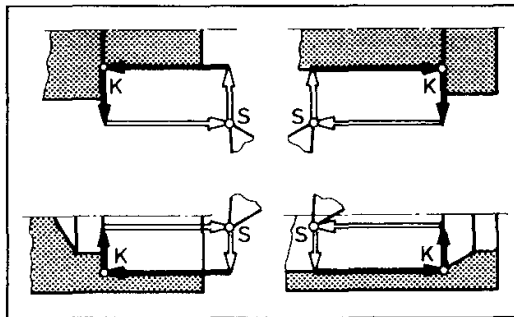





**Cut distribution (D<sub>3</sub>)**

Frequently, a cycle is worked off in several cuts. This is indicated with cut distribution D<sub>3</sub>. The movement sequence consists of the steps 1 to 12.

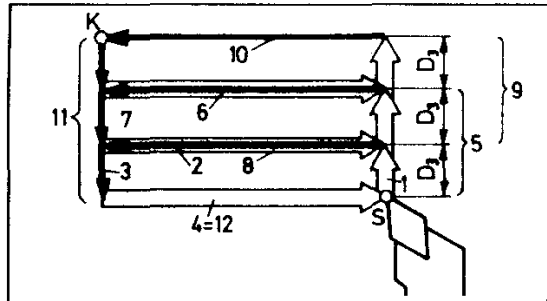

**Example 1**

Longitudinal turning cycle without cut distribution

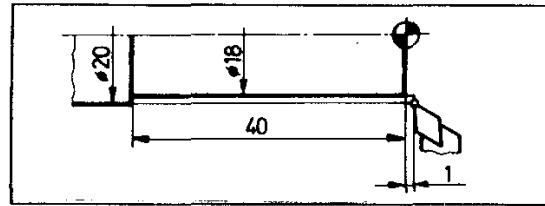

absolute: N.../G84/X18/Z-40/D<sub>3</sub> 1000/F80  
 incremental: N.../G84/U-1/W-41/D<sub>3</sub> 1000/F80

**Example 2**

Longitudinal turning cycle with cut distribution

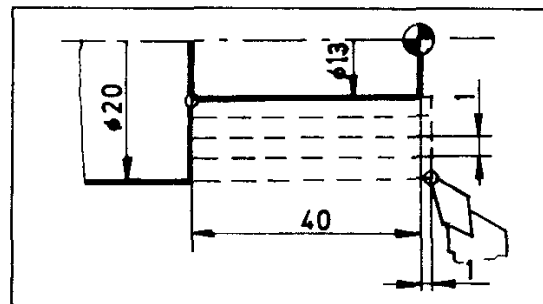

absolute: N.../G84/X13/Z-40/D<sub>3</sub> 1000/F90  
 incremental: N.../G84/U-3.5/W-41/D<sub>3</sub> 1000/F90

Cut distribution D<sub>3</sub> = 1mm (= 1000 μm)

3 x 1mm .....	3 mm
Rest (= finishing cut) .....	0,5 mm
Total advance .....	3,5 mm

**Taper overmeasure (P<sub>0</sub>, P<sub>2</sub>)**

A cycle can be produced with an additional taper overmeasure in X-direction (P<sub>0</sub>) and (or) in Z-direction (P<sub>2</sub>).

The taper overmeasures P<sub>0</sub>, P<sub>2</sub> are programmed always incremental.

The input for taper overmeasure P<sub>0</sub>, P<sub>2</sub> must be carried out in the feed direction. For the example drawn below P<sub>0</sub> and P<sub>2</sub> must be a negative value, otherwise alarm 31 is effected.

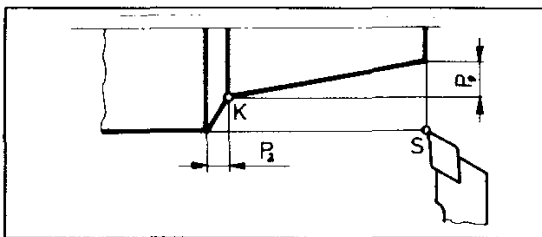

To obtain the same taper, a larger value has to be inserted if starting point S is before the workpiece edge (right).

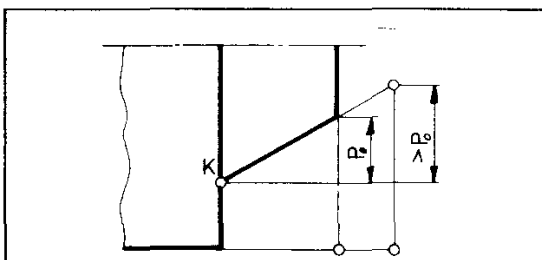

**Example 3**

Longitudinal turning cycle with cut distribution and taper overmeasures

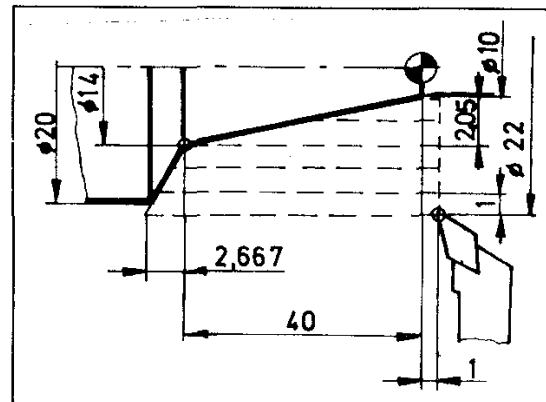

absolute: N.../G84/X14/Z-40/P<sub>0</sub> 2.05/P<sub>2</sub> -2.66  
 /D<sub>3</sub> 1000/F80

### G84 Face turning cycle

Input format:

N 4	G84	Z ± 43 W	X ± 43 U	P <sub>0</sub> ± 43 P <sub>2</sub>	D <sub>3</sub> 5	F 4
		[mm]	[mm]	[mm]	[μm]	[μm/r] [mm/min]

- N ..... Block number
- G84 .. Face turning cycle
- Z(W) } Absolute (incremental) coordinates
- X(U) } of the contour corner point (K)
- P<sub>0</sub> ..... Taper dimension in X (radius value)
- P<sub>2</sub> ..... Taper dimension in Z
- D<sub>3</sub> .... Cut distribution
- F ..... Feed

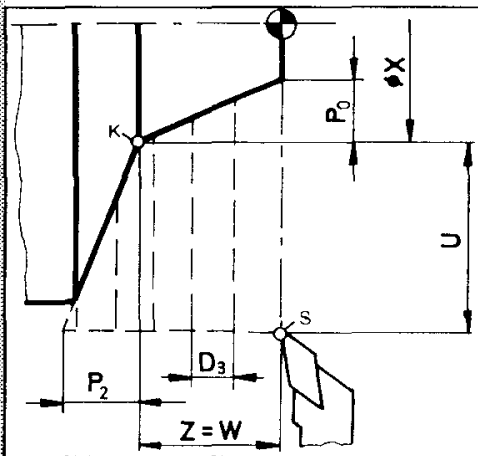

If there is no P<sub>0</sub> or P<sub>2</sub>, it need not be programmed.

#### Difference between longitudinal turning and facing cycle:

With the longitudinal turning cycle X(U) is programmed before Z(W) - thus the first movement is carried out in X-direction.

With the facing cycle Z(W) is programmed before X(U) - thus the first movement is carried out in Z-direction. As for the rest, longitudinal turning and facing cycle are similar.

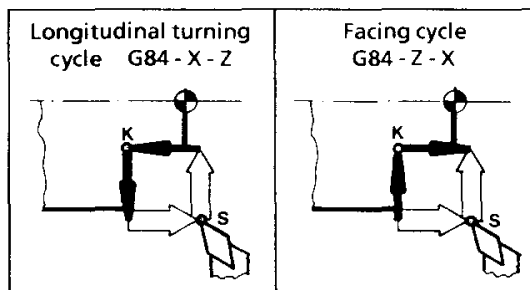

#### Example 1

Facing cycle without cut distribution

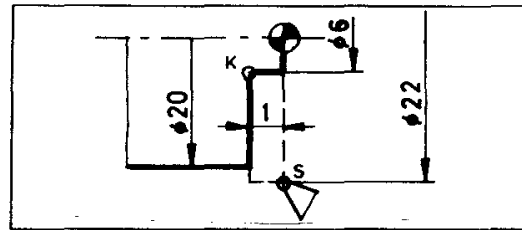

absolute: N.../G84/Z-1/X6/D<sub>3</sub> 1000/F80  
 incremental: N.../G84/W-1/U-8/D<sub>3</sub> 1000/F80

#### Example 2

Facing cycle with cut distribution

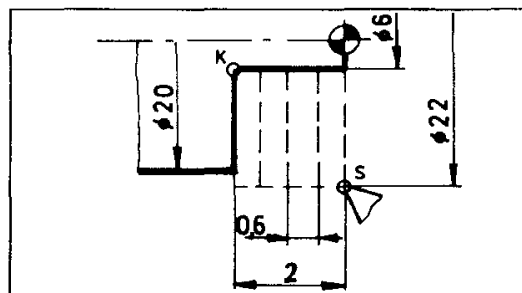

absolute: N.../G84/Z-2/X6/D<sub>3</sub> 600/F100  
 incremental: N.../G84/W-2/U-8/D<sub>3</sub> 600/F100

Cut distribution D<sub>3</sub> = 0,6mm (= 600μm)  
 3 x 0,6 mm ..... 1,8 mm  
 Rest (= finishing cut) ..... 0,2 mm  
 Total advance ..... 2 mm

#### Example 3

Facing cycle with cut distribution and taper overmeasures

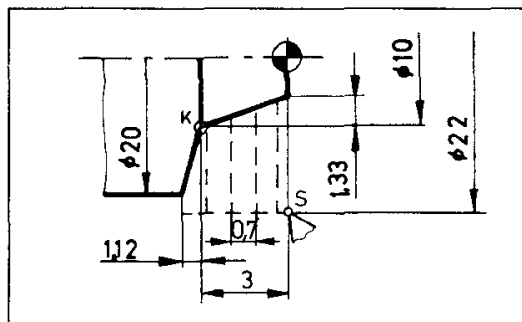

absolute: N.../G84/Z-3/X10/P<sub>0</sub>-1.33/P<sub>2</sub>-1.12  
 /D<sub>3</sub> 700/F80  
 incremental: N.../G84/W-3/U-6/P<sub>0</sub>-1.33/P<sub>2</sub>-1.12  
 /D<sub>3</sub> 700/F80



## G85 Thread cycle

Input format:

N4	<b>G85</b>	$X$ $U \pm 43$	$Z$ $W \pm 43$	$P_2 \pm 43$	$D_3$ 5	$D_6$ 5	$F$ 4
		[mm]	[mm]	[mm]	[µm]	[µm]	[µm]

- N ..... Block number
- G85 ... Thread cycle
- X (U) } Absolute (incremental) coordinates
- Z (W) } of the final thread point (K)
- P<sub>2</sub> ..... Thread lead-out
- D<sub>3</sub> ... Cutting depth of the first cut
- D<sub>6</sub> ... Thread depth
- F ..... Pitch

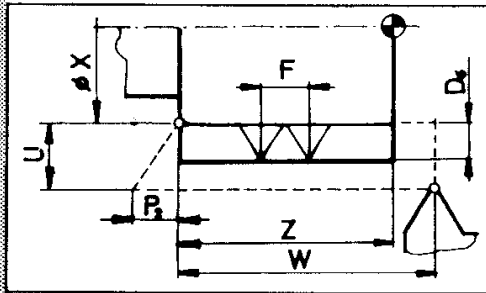

**Definition**

A cycle is a movement sequence of the tool which consists of a series of individual movements.

- G00 Movement with rapid motion
- Movement with programmed pitch (F) in µm/r

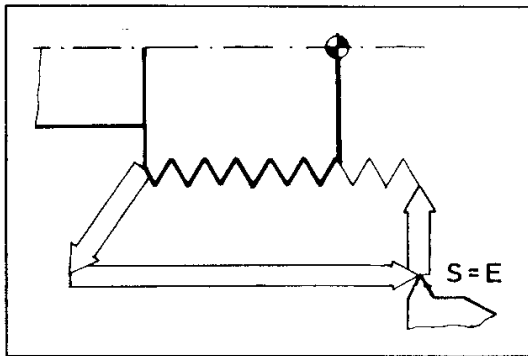

A cycle always has a closed movement sequence: starting point (S) = final point (E)  
The starting point (S) is approached in the block before G85.

Contour corner point (K)

The movement sequence of a cycle is defined by starting point (S) and contour corner point (K). In accordance with the position of S and K to each other there are four kinds of cycle that you get as a result.

K is described with X,Z absolute or with U,W starting from S (incremental).

**External right-hand thread**

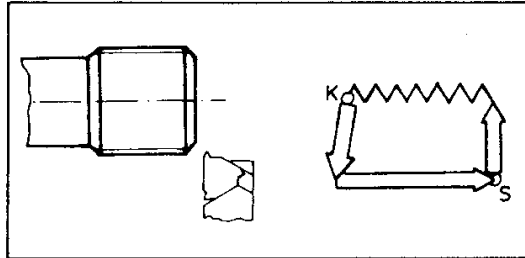

**External left-hand thread**

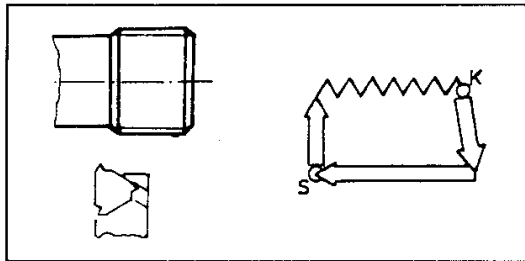

**Internal right-hand thread**

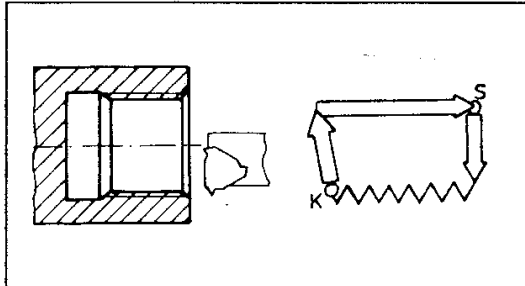

**Internal left-hand thread**

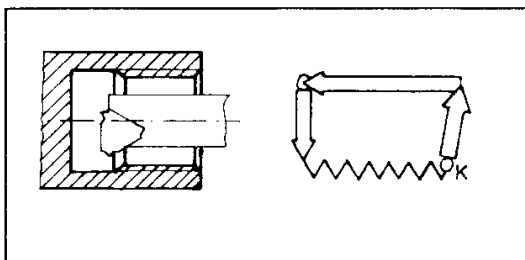



Thread lead-in (A) - thread lead-out (P<sub>2</sub>)

During start of thread-cutting the Z-slide has to be accelerated. At the end of the thread the Z-slide has to be decelerated. The thread pitch is not constant in the acceleration and deceleration phase. Therefore this phase must be placed outside the workpiece.

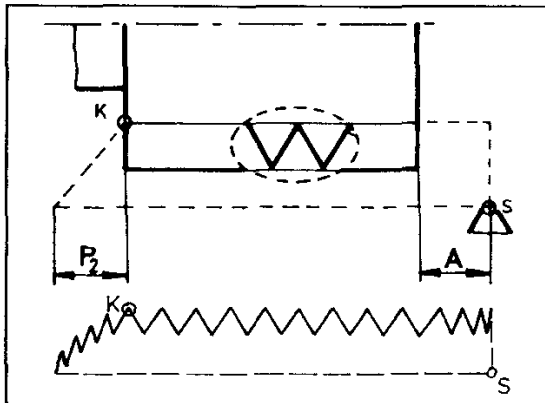

The starting point (S) has to be determined in such a way that there is a necessary thread lead-in (A) of approx. 3 to 4 mm.

For the thread lead-out (P<sub>2</sub>) approx. 1 to 2 mm should be programmed. The threading tool moves out obliquely.

Thread depth (D<sub>6</sub>)

You can find the thread depth for the turning tools used here in the tables of the chapter "thread-cutting".

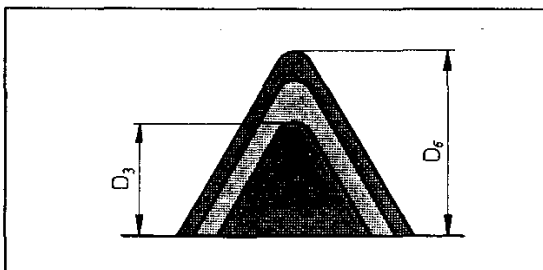

Threading depth of the first cut (D<sub>3</sub>)

A thread is always cut in several sequences. The first threading depth is programmed with D<sub>3</sub> in µm.

The further threading depths are calculated by the computer in such a way that the chip cross-section remains constant.

The advance for the individual cuts is carried out in X direction only.

Thread pitch (F)

The thread pitch is programmed in µm; e.g. 1,25 mm pitch; input = F1250

You can find the right thread pitch for standardized threads in the tables of the chapter "thread-cutting".

Example:

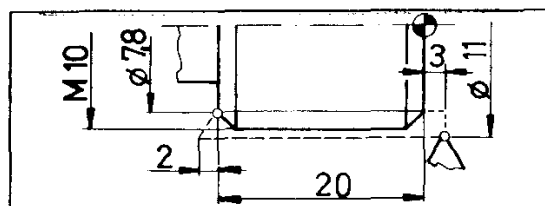

absolute: N.../G85/X7,8/Z-20/P<sub>2</sub>-2/D<sub>3</sub> 600  
/D<sub>6</sub> 1100/F1500  
incremental: N.../G85/U-1,6/W-23/P<sub>2</sub>-2/D<sub>3</sub> 600  
/D<sub>6</sub> 1100/F1500





## G86 Cut-in cycle

Input format:

N 4	<b>G86</b>	X ± 43	Z ± 43	D <sub>3</sub> 5	D <sub>5</sub> 5	F 4
		[mm]	[mm]	[µm]	[µm]	[µm/r] [mm/min]

- N ..... Block number
- G86 ... Cut-in cycle
- X(U) } Absolute (incremental) coordinates
- Z(W) } of the contour corner point (K)
- D<sub>3</sub> ... Advance per cut (radius value)
- D<sub>5</sub> ... Tool width
- F ..... Feed

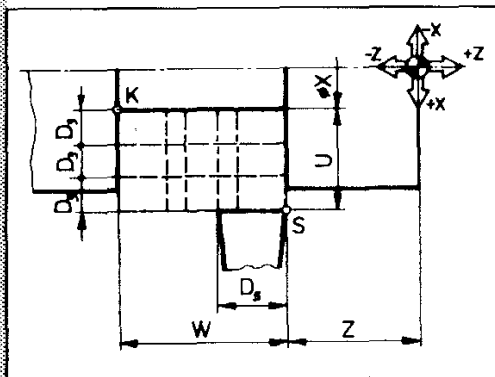

### Cut-in width = tool width

The tool movement is carried out in X direction. The tool advances by a measure of D<sub>3</sub>, moves a little back (for chip breaking), advances again by a measure of D<sub>3</sub> etc., until point K is reached.

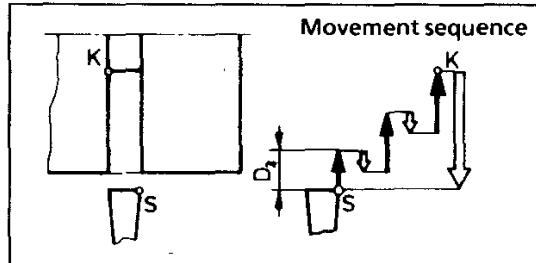

### Cut-in width larger than tool width

If the width of the programmed cut-in is larger than the tool width, the control system grades the remaining cut-in width after the first cut-in into partial cut-ins with the same chip width. Overlapping of the individual partial cut-ins is at least 1/10 mm.

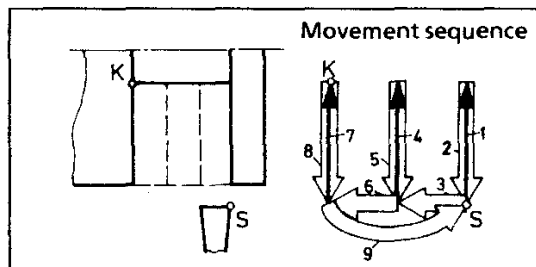

Each cut-in movement (1,4,7) is graded additionally by D<sub>3</sub> (see previous drawing).

The cut-in cycle consists of several single motions.

- ➡ G00 Movement with rapid motion speed
- ➡ G01 Movement with programmed feed speed (F) in mm/min or µm/r.

### Contour corner point (K)

The cut-in depth and width is defined by starting point (S) and contour corner point (K). S is traversed in a block before G86.

K is described with X, Z absolute or with U, W from S (incremental)

### Tools used:

Parting-off tool:	Cut-in tool:
Tool width = 3mm	Tool width = 1,2 mm max. cut-in depth = 1,5

When adjusting the tool (chapter 4,5) the left cutting edge has to be adjusted



**Example 1**

Cut-in for Seeger circlip ring

Speed with aluminium = 1500 rpm

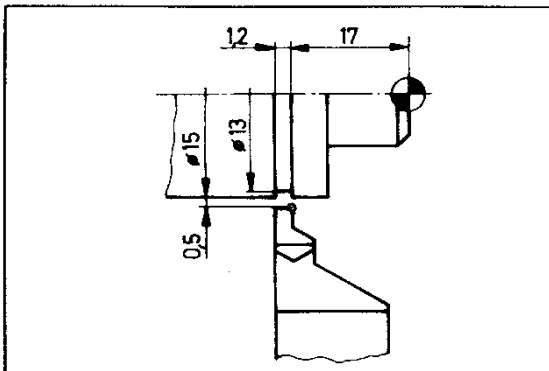

absolute: N.../G86/X14.3/Z-17/D<sub>3</sub> 850/D<sub>5</sub> 1200  
/F22mm/min

incremental: N.../G86/U-0.85/Z 1,2/D<sub>3</sub> 850/D<sub>5</sub> 1200  
/F22 mm/min

**Example 2**

Cut-in with 8 mm width in aluminium

Speed = 950 rpm

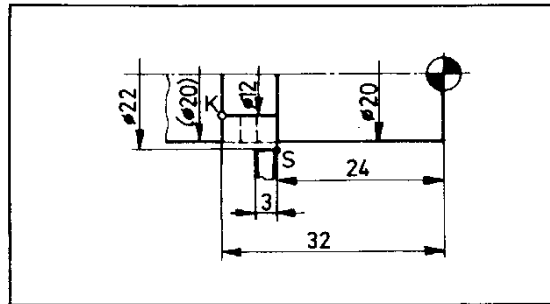

absolute: N.../G86/X12/Z-24/D<sub>3</sub> 800/D<sub>5</sub> 300/F150 mic/U  
incremental: N.../G86/U-5/W8/D<sub>3</sub> 800/D<sub>5</sub> 300/F150 mic/U

**Cut-in values for sealing rings according to DIN 471**

d	d <sub>1</sub>	m
9	8,6	1,2
10	9,6	1,2
12	11,5	1,2
14	13,4	1,2
15	14,3	1,2
17	16,2	1,2
18	17	1,3
20	19	1,3
25	23,9	1,3
30	28,6	1,6
35	33	1,6
40	37,5	1,85
50	47	2,15
60	57	2,15



## The reference point (R)

**Position:**

After setting up a blank, the reference point is automatically on the extreme right end of the blank on the center line.

**Meaning:**

All absolute dimension values on the workpiece refer to the reference point. By special dimensioning of the workpiece it may be useful to set off the reference point during machining.

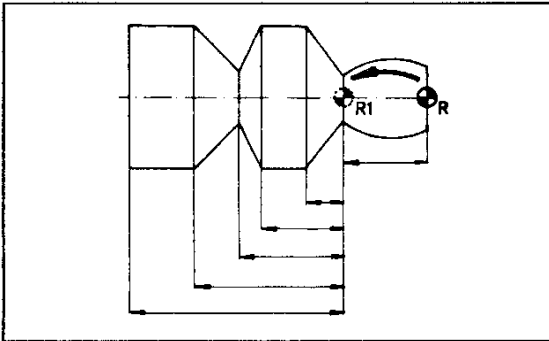

**Offset:**

With G92 the offset values for the reference point (R) are indicated. With G59 the offset indicated in block G92 is activated.

With G56 the offset is reversed - R is again in the original position. G56 is not necessary at program end - when calling up a new program, the reference point offset is cancelled automatically.

### G92 Data for reference point offset

**Input format:**

N 4	<b>G92</b>	X ± 43 U (mm)	Z ± 43 W (mm)
-----	------------	---------------------	---------------------

X, Z (or U,W) are the offset values. The new reference point (R<sub>1</sub>) is offset by this values from the old reference point (R).

If there is no reference point (R) the offset values refer to the machine starting point (M).

X is a diameter value  
U is a radius value

**Example:**

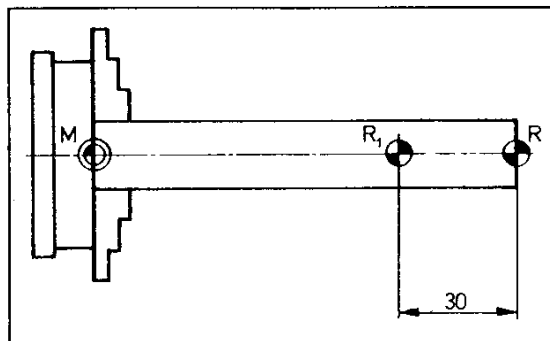

absolute: N.../G92/X0/Z-30  
incremental: N.../G92/U0/W-30



## G94 / G95 Feed unit

Input format:

N4	G94
N4	G95

- Switch-on state is G94
- G94 and G95 are self-holding until they are cancelled
- G94, G95 can be programmed as often and wherever one wants to

For the feed size or feed speed the letter F is used.

### 1. Feed programming with G94

= path of turning tool per minute

F [mm/min]

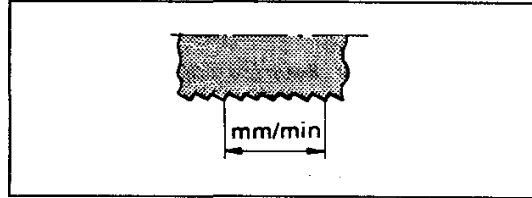

### 2. Feed programming with G95

= path of turning tool per main spindle revolution

F [ $\mu\text{m}/\text{r}$ ] ..... 1  $\mu\text{m}$  = 1/1000 mm

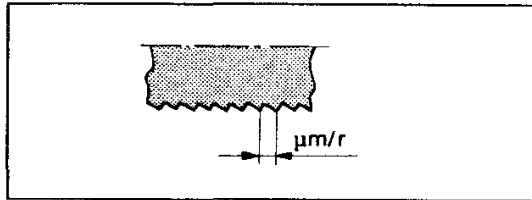

Conversion:

$$F (\text{mm}/\text{min}) = S (\text{rpm}) \times F (\text{mm}/\text{r})$$

$$F (\text{mm}/\text{r}) = \frac{F (\text{mm}/\text{min})}{S (\text{rpm})}$$

S.... Main spindle speed







## 7. NOTES FOR THE SOFTWARE COMPILATION

### Design:

The power supply unit and the stepping motor control of the Compact 5 PC are accommodated in a smaller control cabinet. These components are identical to those of the Compact 5 PC and therefore the same spare parts can be employed.

The Compact 5 PC must be controlled by an external computer. The Compact 5 PC is to be connected to this computer like a peripheral, such as a printer, plotter or a paper tape reader / puncher. The computer must be fitted with a Centronics interface for connection to the Compact 5-PC. This interface is a parallel interface, i.e. data is transmitted on eight lines simultaneously (Centronics is the company name of an American printer manufacturer and the definition of this printer interface has become a quasi-standard worldwide).

The connector provided on the Compact 5 PC is a 25-pin D subminiature jack connector with the following pin assignment:

Pin No.	Signal designation
1	STROBE
2	data bit 0
3	data bit 1
4	data bit 2
5	data bit 3
6	data bit 4
7	data bit 5
8	data bit 6
9	data bit 7
10	speed pulse light barrier (100 p/rev.)
11	emergency-off and chip protection door
12	synchronous pulse light barrier
18 - 25	earth

This interface is connected via a small interface pc board directly to the stepping motor card and the light barrier. This interface board accommodates a 4-fold DIP switch with which the user can set various modes of operation.

### Signal description:

The signal inputs only process TTL signals and the signal outputs offer TTL signals.

The strobe input serves for the synchronisation of the data lines. If a pulse is transmitted on this line, the data which are offered at this time to the data lines bit 0 - bit 7 are accepted as being valid. On many computers this signal is automatically produced by the hardware, on other computers the programmer has to generate this signal in the software.

The signal emergency-off and chip protection door is a signal output and is set to "Low" when the emergency-off button is pressed or if the chip protection door is open. (The limit switch for the chip guard is not installed as a standard feature. Merely the connection for it is provided!).

The signal speed pulse is a signal output and provides 100 pulses per revolution of the main spindle. The pulse duty factor is not defined and also depends on the speed.

The signal synchronous pulse is a signal output and provides one pulse per revolution of the main spindle. The length of the pulse depends on the speed and the pulse is not synchronised with the slopes of the speed pulses.

The meaning of the data signals depends on the setting of the 4-fold DIP switch. These signals, however, always serve to trigger the stepping motors.

In order to picture the operation of the stepping motor, it is a good idea to imagine a coordinate system with the four cardinal points. These points correspond to the directions of the magnetic fields in the stepping motor and one magnetic field can be produced with one winding (when an electric current is allowed to pass through the winding). If more than one winding is switched on at the same time, the direction and strength of the magnetic field are derived by vectorial addition. An example: If the windings "North" and "South" are activated at the same time, the two magnetic fields cancel each other out and the resultant magnetic field has zero strength and the direction is undefined. However, if the windings "South" and "West" are switched on simultaneously, the direction of the resultant magnetic field is "South-West" and the strength is 1.41 times that of a single field. (Diagonal of a square).

The rotor of a stepping motor is designed so that it always tries to align itself in the direction of the magnetic field produced by the stator. Therefore, if the current is suitably switched on and off in the windings of the motor, the rotor rotates about a certain angle and it thus moves stepwise from one set magnetic field direction to the next.

There are two ways in which the windings can be triggered:

1) Full-step mode	1st step	S-W
	2ndstep	W-N
	3rd step	N-E
	4th step	E-S
2) Half-step mode	1st step	S-W
	2ndstep	W
	3rd step	W-N
	4th step	N
	5th step	N-E
	6th step	E
	7th step	E-S
	8th step	S



The direction of rotation depends on whether one controls from 1 to 2 etc., or, for example, from 1 to 8, from 8 to 7 etc.

The advantages of the half-step mode of operation lie in the double resolution with the same motor design, the disadvantage is a loss of torque because only one winding is active at each intermediate step and only about 70% of the maximum torque is available. Moreover, more stringent demands have to be placed on the computing speed owing to the higher resolution.

The Centronics interface has eight data lines. As four windings per motor have to be triggered, the windings can be directly controlled by two motors.

If the sequence of winding control no longer has to be performed directly by the connected computer, two lines per axis drive are, in principle, sufficient, i.e. one line where the direction of rotation is determined and a second line where the steps are output. (One pulse on the second line means that the stepping motor is to move one step in the direction or rotation specified on line one.)

**Abbreviations:**

- VS ... full step
- HS ... half step
- T/R .. step/direction signal
- dir .. direct winding control
- RL ... cw
- LL ... ccw

**Table for the 4-fold DIP switch:**

Mode	1	2	3	4
VS T/R RL RL	on	on	on	on
VS T/R LL RL	on	off	on	on
VS T/R RL LL	on	on	off	on
VS T/R LL LL	on	off	off	on
VS dir RL RL	off	on	on	on
VS dir LL RL	off	off	on	on
VS dir RL LL	off	on	off	on
VS dir LL LL	off	off	off	on
HS dir RL RL	off	on	on	off
HS dir LL RL	off	off	on	off
HS dir RL LL	off	on	off	off
HS dir LL LL	off	off	off	off
HS T/R RL RL	on	on	on	off
HS T/R LL RL	on	off	on	off
HS T/R RL LL	on	on	off	off
HS T/R LL LL	on	off	off	off

**Characteristics of the axis drives for the Compact 5 PC:**

The specified values relate to full-step control and are to be converted for half-step control accordingly.

The given values relate to the slide movements.

**Resolution:**

One step corresponds to 1000/72 micrometre.

**Speed:**

100 Hz correspond to 83.33 mm/min feed rate

**Maximum speed:**

840 Hz corresp. to 770 mm/min rapid motion

**Start-stop frequency:**

598 Hz corresp. to 499 mm/min feed rate

**Acceleration time:**

from 0 to 598 Hz 0 sec

from 598 to 840 Hz 1 sec (linear acceleration)

**"dir" mode:**

The data lines D0 to D3 are assigned to the stepping motor in the X-axis (cross slide). The sequence of the windings is "E", "S", "W", "N".

The data lines D4 to D7 are assigned to the stepping motor in the Z-axis (longitudinal slide).

The sequence of the windings is the same as for the X-axis.

**"T/R" mode:**

The data lines

- D0 is direction motor X
- D1 is steps motor X
- D2 is direction motor Z
- D3 is steps motor Z





# Menu summary

## Notes

You can select and activate the individual menu points with the function keys F1 to F10 or with the space bar.

A command can be interrupted or a return to the previous menu level activated with the key Esc.

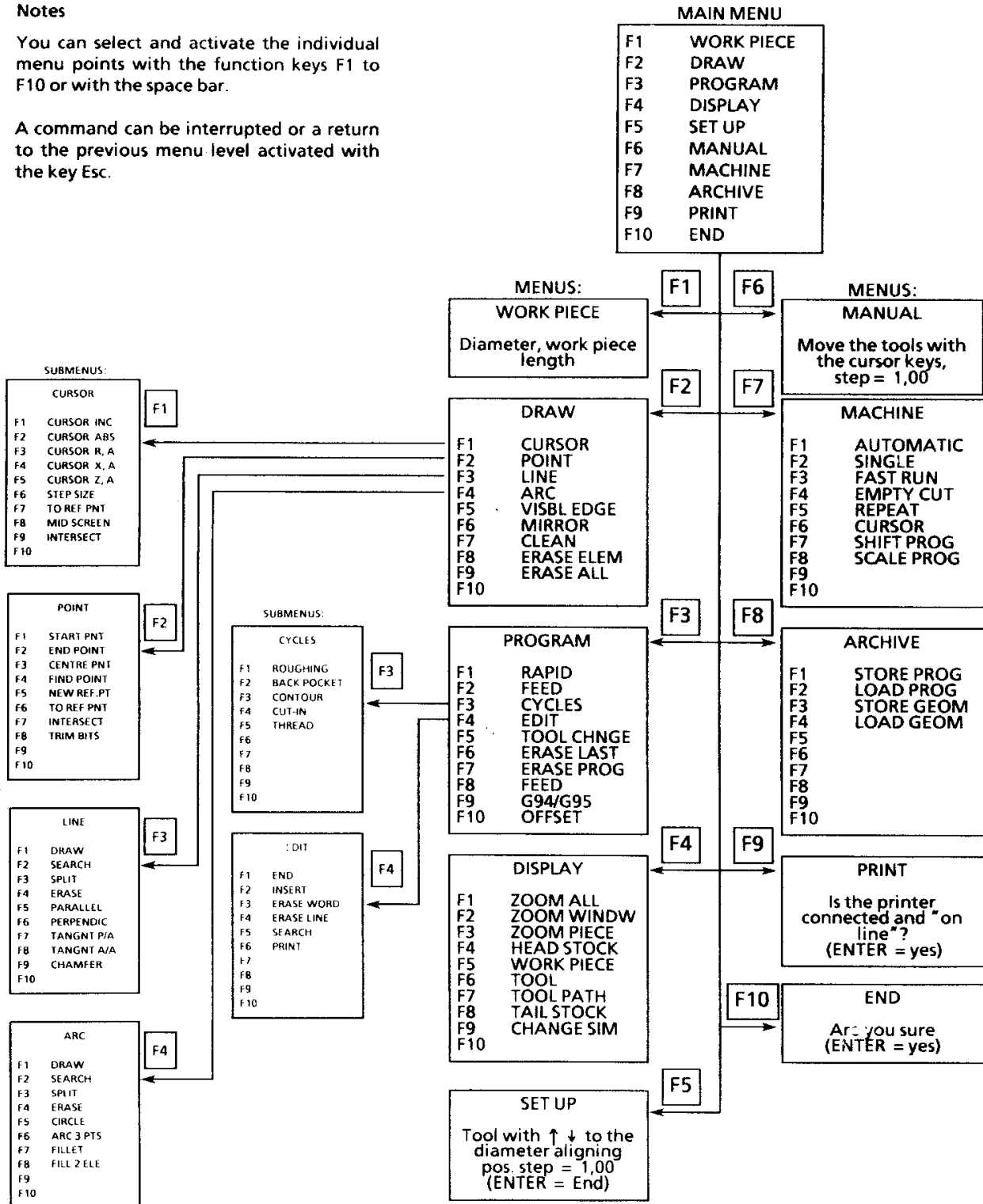





### Hotkeys - draw

In order to facilitate a more efficient programming, so-called "hotkeys" were introduced in this software. Hotkey = single-key commands, which are effective in every menu level. You can display a work piece contour on the screen more quickly with the use of these hotkeys.

Example: Constructing a line

**Possibility 1 - Menu**

1. F2 Recall - menu DRAW
2. F2 Recall - submenu POINT
3. Moving the cursor to the starting point
4. F1 Determining the starting point
5. Moving the cursor to the end point
6. F2 Determining the end point
7. Esc. Exit from the submenu POINT
8. F3 Recall - submenu line
9. F1 Drawing a line

**Possibility 2 - hotkeys**

1. Moving the cursor to the starting point
2. S Determining the starting point
3. Moving the cursor to the end point
4. + Drawing the line to the cursor position, a new starting point at the same time

Summary - hotkeys

Key	Cursor commands
	Position the cursor incrementally
	Position the cursor by entering the radius and angle
	Cursor to the middle of the screen
	Cursor to the reference point
	Doubling the step size of the cursor
	Halving the step size of the cursor

Key	Screen commands
	Redrawing the screen contents
	Zooming a screen window
	Zooming the work piece
	Cursor as a graticule
	Reduced cursor

Key	Searching commands
	Finding the point
	Searching for the line
	Searching the circle, arc
	Searching any point of intersection











Key	Point commands
	Determining the starting point
	Determining the end point
	Determining the centre point

Key	Geometric commands
	Adding a fillet
	Adding a chamfer (45°)
	Cleaning the bit
	Drawing a line to the cursor
	Erasing the element





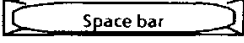

**Note:**  
Letters can be entered as capitals or small letters.

### Hotkeys - machine













You can move the slides and influence the machining cycles by means of these keys.

	Move the slides in the -X direction
	Move the slides in the +X direction
	Move the slides in the -Z direction
	Move the slides in the +Z direction
	Enlarge the travel path of the stepping motors
	Reduce the travel path of the stepping motors
	Increase the feed
	Reduce the feed
	Stop the slides (= intermediate stop)
	Interrupt the machining

#### Travel path of the stepping motors

	10 mm (= largest travel path)
	5 mm
	1 mm (= switch-on condition)
	0,5 mm
	0,1 mm
	0,05 mm
	0,01 mm (= smallest travel path)

#### Altering the programmed feed

	200 %
	150 %
	120 %
	100 % (= switch-on condition)
	80 %
	60 %
	50 %
	40 %
	30 %
	20 %
	10 %
	5 %
	0 %