

COLCHESTER BANTAM



**INSTRUCTION AND
SPARE PARTS MANUAL**

THIS MANUAL

applies to the Colchester 5½ in. (140 mm) Bantam Lathe. A thorough understanding of its contents will help you obtain the best results from your machine.

Our Technical Service Department is at your disposal and will always be pleased to discuss the application of Colchester Lathes and their attachments. Our aim is to ensure that you obtain maximum satisfaction from your machine.

The serial number is stamped into the lathe bed at the tailstock end and **MUST** be quoted in all communications regarding your lathe. Due to the Company's policy of continuous improvement, designs may be modified or changed at any time and this manual applies only to the machine with which it is issued.

THE SERIAL NUMBER OF YOUR MACHINE IS

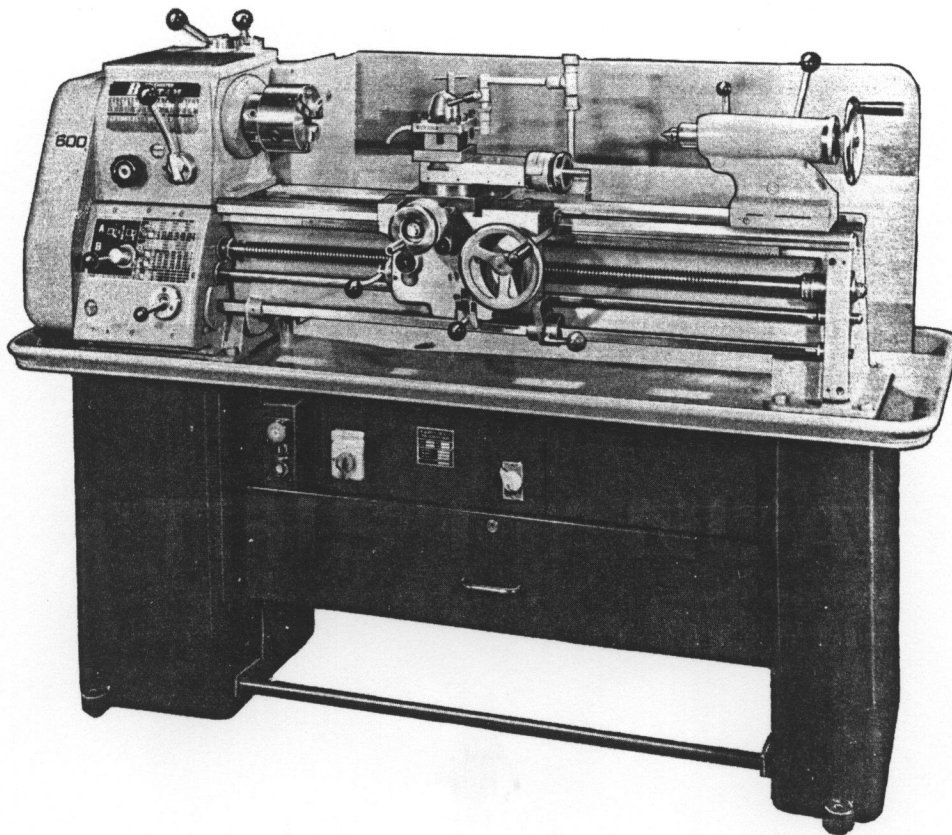

ONE COPY OF THIS MANUAL IS SUPPLIED FREE WITH EACH MACHINE
FURTHER COPIES MAY BE PURCHASED ON APPLICATION

INDEX

SPECIFICATION 3

INSTALLATION

FOUNDATION PLANS	4
LOCATION, LIFTING, CLEANING & LEVELLING	5
ELECTRICAL WIRING	6, 7
CHUCK MOUNTING, ALIGNMENT CHECKS	8
LUBRICATION	9
LUBRICATION CHART	10

OPERATION

HEADSTOCK	11
DRIVE	12
ENGLISH GEARBOX	13 - 14
CONTINENTAL GEARBOX & APRON	15 - 16
SADDLE & SLIDES, BED & TAILSTOCK	17

ACCESSORIES

LIST OF EQUIPMENT WITH CODE NUMBERS	18
COOLANT SYSTEM & QUICK CHANGE TOOLPOST	19
STATIONARY & TRAVELLING STEADY	20
REAR TOOLPOST, FEEDSTOPS	21
TELESCOPIC TAPER ATTACHMENT	22
CAPSTAN AND BAR FEED, LOW VOLT LIGHTING	23

BRIEF SPECIFICATION

- EAGLE 20** - 5½ in x 20 in straight bed floor mounted lathe, with English quick change gearbox.
EAGLE 30 - 5½ in x 30 in straight bed floor mounted lathe, with English quick change gearbox.
CONDOR 20 - 140 mm x 510 mm straight bed floor mounted lathe, with Continental quick change gearbox
CONDOR 30 - 140 mm x 762 mm straight bed floor mounted lathe, with Continental quick change gearbox

CAPACITIES		English	Metric
Height of centres	...	5½ in	143 mm
Turning diameters			
Over bed	...	11½ in	286 mm
Over cross slide	...	7 in	178 mm
Distance between centres	...	20 in or 30 in	508 mm or 762 mm
Diameter of faceplate	...	10 in	254 mm
Diameter of driving plate	...	6¾ in	175 mm
Capacity of travelling steady	...	1½ in	35 mm
Overall length of machine	...	53 in or 64 in	1345 mm or 1630 mm
Overall width of machine	...	25 in	635 mm
Weight	...	980 lbs or 1020 lb	445 kg. or 463 kg
HEADSTOCK			
Spindle bore (Max. bar dia)	...	1 in	25.4 mm
Spindle nose, camlock	...		3 in D.I.
Taper in spindle nose	...		No. 4 M T
Number of spindle speeds (single speed)	...		8
Range of spindle speeds (single speed)	...		36-800 r.p.m.
Number of spindle speeds (two speed)	...		16
Range of spindle speeds (two speed)	...		36-1600 r.p.m.
CARRIAGE			
Total travel of cross slide	...	6⅞ in	175 mm
Total travel of top slide	...	3⅞ in	92 mm
Height from top of top slide to centre line of spindle	...	1½ in	38 mm
Max. tool shank size	...	½ in x 1 in	12.5 mm x 25.4 mm
THREADS AND FEEDS			
TYPE OF GEARBOX		EAGLE	CONDOR
		English	Continental
PITCH OF LEADSCREW		4 t.p.i.	6 mm
Number of metric pitches	...	15	27
Range of metric pitches	...	0.5 mm to 6 mm	0.2 mm to 6 mm
Number of Whitworth threads	...	30	26
Range of Whitworth threads	...	3.5 to 80 t.p.i.	3.5 to 80 t.p.i.
Number of Module pitches	...	—	22
Range of Module pitches	...	—	0.3 to 6.0
Number of diametral pitches	...	18	—
Range of diametral pitches	...	7 to 48	—
Number of sliding and surfacing feeds shown	...	26	16
Range of sliding feeds001 to .028 in/rev	.001 to .032 in/rev
Range of surfacing feeds0005 to .014 in/rev	.0005 to .016 in/rev
			0.02 to 0.7 mm/rev
			0.01 to 0.35 mm/rev
TAILSTOCK			
Spindle travel (No. 3 M.T. Centre fitted)	...	4½ in	108 mm
Spindle travel (Standard tang drill fitted)	...	3½ in	89 mm
Taper in spindle	...		No. 3 M.T.
DRIVE			
Single speed motor	...	1 h.p. 3 phase 50 cycle	
Two speed motor	...	2/1 h.p. 3 phase 50 cycle	

STANDARD EQUIPMENT SUPPLIED WITH THE MACHINE
 (for details of accessories see page 20)

Apron Control Unit for Spindle (Forward/Stop/Reverse). Swivel Toolblock. Rear mounted splash guard 10" diameter faceplate Foot actuated spindle brake Travelling steady. Pedestal base tool cabinet. D.iving Plate Two Morse taper centres. Bedway wipers. Chip and coolant tray. Electrical equipment for standard 50 cycle 3 phase A/C supply Set of spanners and keys. Instruction and spare parts manual Electric coolant pump, tank and fittings

FOUNDATION PLANS

20 in (508 mm) BED

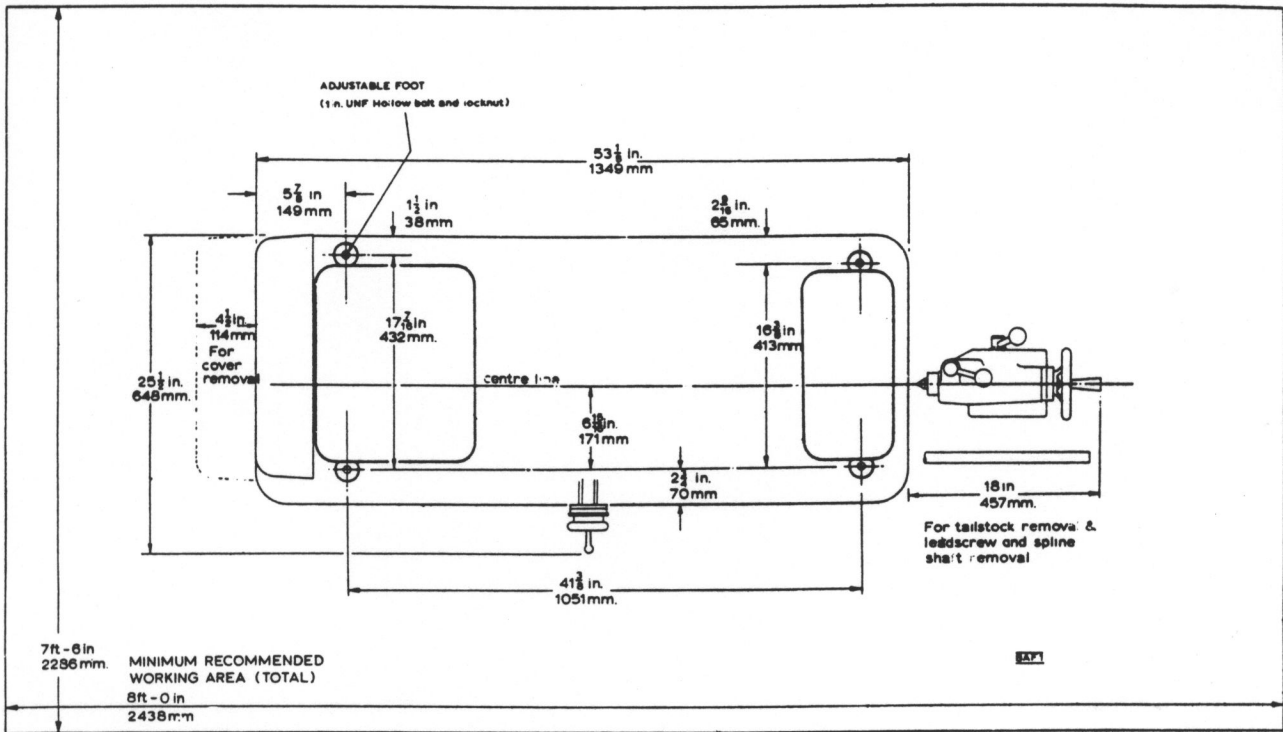

30 in. (762 mm) BED

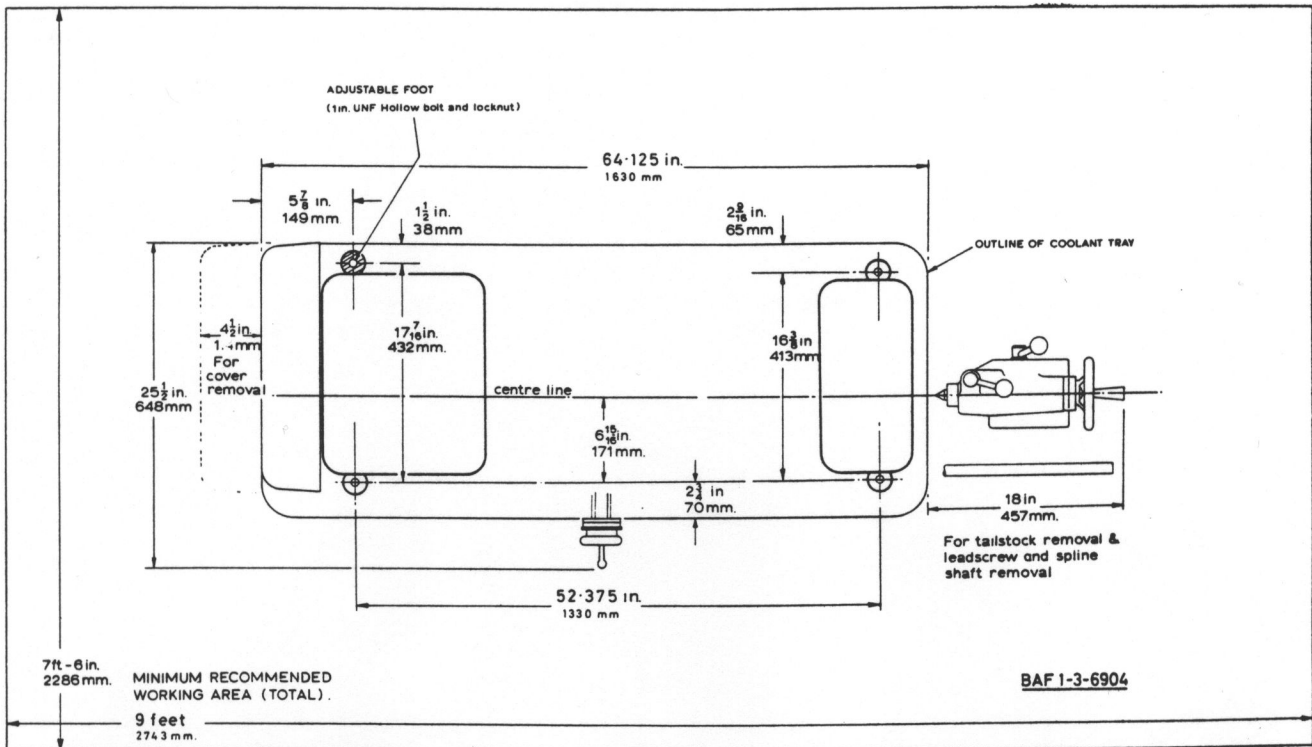

INSTALLATION

LOCATION

Provided that the floor is firm, reasonably level and able to bear the weight (up to 1,052 lb or 475 kg), this machine can be located in any convenient position.

In order to achieve the high standards of accuracy to which your Colchester lathe is capable of working, however, the machine is best located on a solid concrete base, made as level as possible and free from vibration. Wooden floors are not recommended because changes in atmospheric conditions may affect alignment of the lathe.

The foundation plans opposite show the main machine dimensions together with recommended minimum space requirements for efficient operation and servicing.

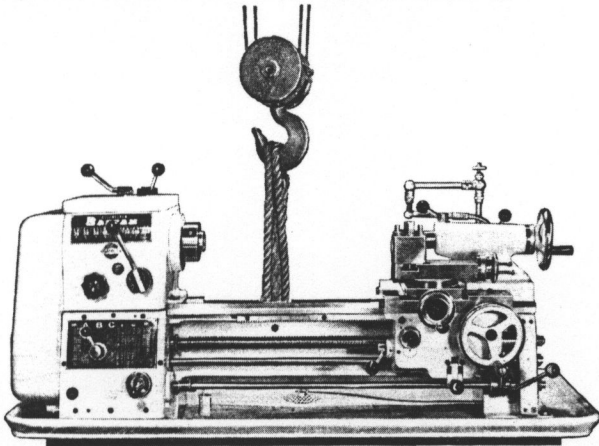

LIFTING

On 20 in. (510 mm) machines, a cross-bar is fitted between the bedways immediately in front of the headstock.

On 30 in. (750 mm) lathes a tapped hole is provided between the bedways for a lifting eye.

Proper equipment must be available for raising the machine by means of rope or cable through the cross-bar or lifting eye. Under no circumstances should the lathe be lifted by means of a bar through the spindle bore or by ropes around the headstock and tailstock. Balance the machine during lifting by moving the carriage towards the tailstock end of the bed.

CLEANING

When the lathe is delivered, all bright machined surfaces are covered by a heavy protective coating. This must be removed with white spirit or kerosene before attempting to use the machine. **DO NOT USE CELLULOSE SOLVENTS AS THESE WILL DAMAGE THE PAINT WORK.**

Particular attention should be paid to the slides and spindle nose, and it is essential that the end guard is opened and the assemblies covered by this carefully cleaned. All traces of the cleaning agent should then be removed and the bright surfaces given a light coating of Shell Tellus 27 Oil.

POSITIONING

Machines Free Standing

For all work under normal conditions, the machine will perform perfectly when free standing.

Place the machine in position on the three fixed feet. Screw down the adjustable support and lock at a level where it shares the machine weight without causing any of the fixed feet to lose contact with the floor.

Any vibration that is apparent when the machine is run can be eliminated by resetting the adjustable support foot while the lathe is running.

Machines Bolted Down

When the machine is used regularly for high speed out-of-balance work, it is recommended that the cabinet be bolted down to a firm foundation by means of four ½ in. diameter bolts.

As before, place the machine in position over the four holding down bolts so that it stands on the three fixed feet.

Screw down the adjustable support foot and lock at a level where it shares the machine weight without causing any of the fixed feet to lose contact with the floor.

Securely tighten the four holding down bolts and check that the cross wind alignment of the machine has not been disturbed.

LEVELLING

A precision engineer's level should be used and readings taken across the bed at the headstock and tailstock ends and in two positions on the front and rear bed shears in a longitudinal direction. If necessary, mis-alignment can be rectified by re-setting the adjustable foot.

ELECTRICAL WIRING

Wiring the machine into mains supply should be made only by a competent electrician, with all wiring of permanent character. All internal wiring is carried within the cabinet, properly shielded to provide a high degree of safety. It is essential that an efficient earth is provided in the installation as in the wiring diagrams shown in the following pages.

A safety micro-switch is fitted in the machine to isolate the motor supply when the end-guard is removed.

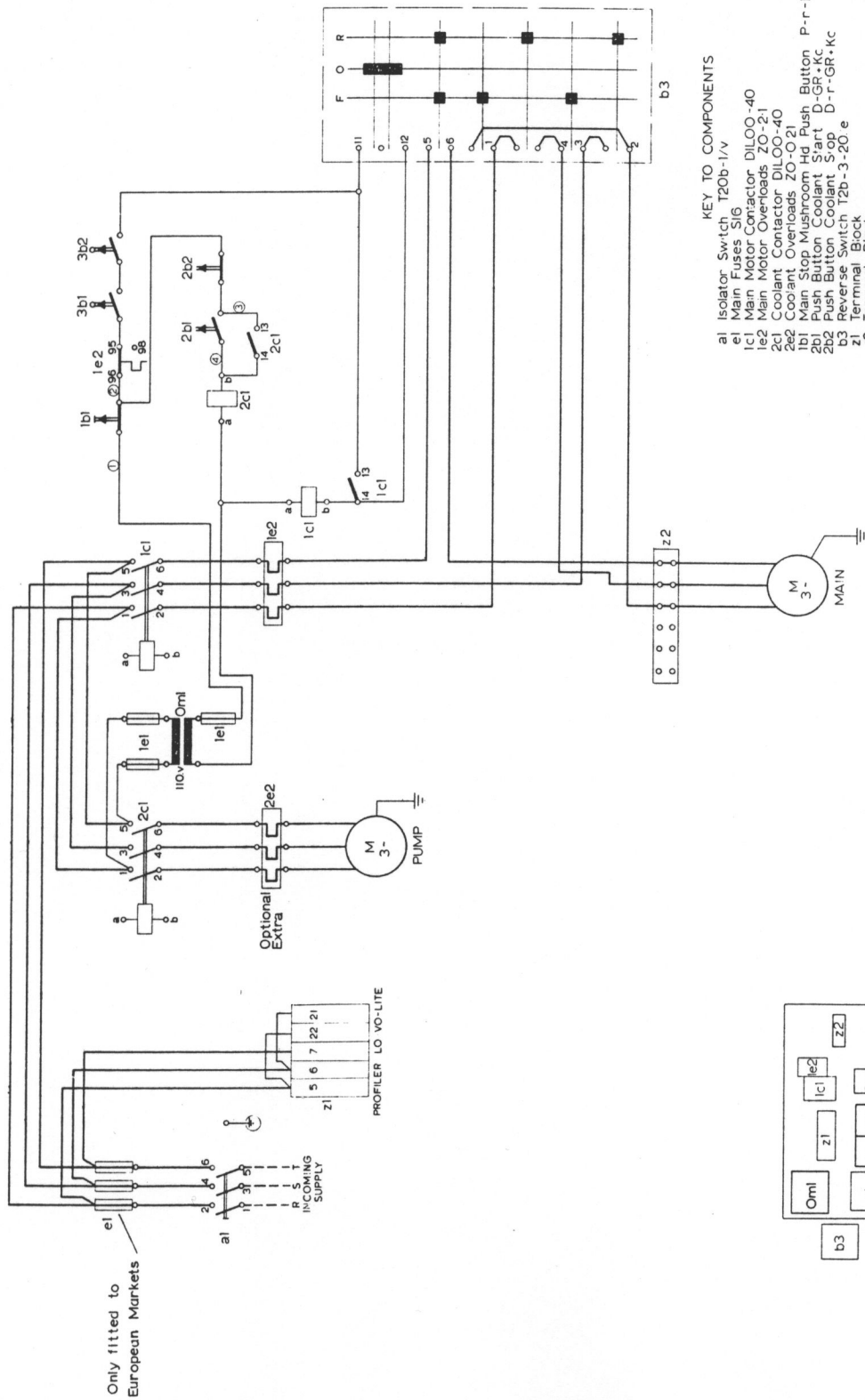

Only fitted to European Markets

KEY TO COMPONENTS

- a1 Isolator Switch T20b-1/V
- e1 Main Fuses S16
- 1c1 Main Motor Contactor DIL00-40
- 1e2 Main Motor Overloads ZO-21
- 2c1 Coolant Contactor DIL00-40
- 2e2 Coolant Overloads ZO-O21
- 1b1 Main Stop Mushroom Hd Push Button P-r-IP65+Kc
- 2b1 Push Button Coolant Start D-GR+Kc
- 2b2 Push Button Coolant Stop D-r-GR+Kc
- b3 Reverse Switch T2b-3-20 e
- z1 Terminal Block
- z2 Terminal Block
- 3b1 Endguard Limit Switch Burgess 3 BR or Unimax 2HBJ-1
- 3b2 Brake Limit Switch Burgess 3BR or Unimax 2HBJ-1
- 1e1 Control Fuses S16
- Omi Control Transformer

WIRING DIAGRAM 500v 3ph 50hz 3wire
SINGLE SPEED 110v Control Circuit

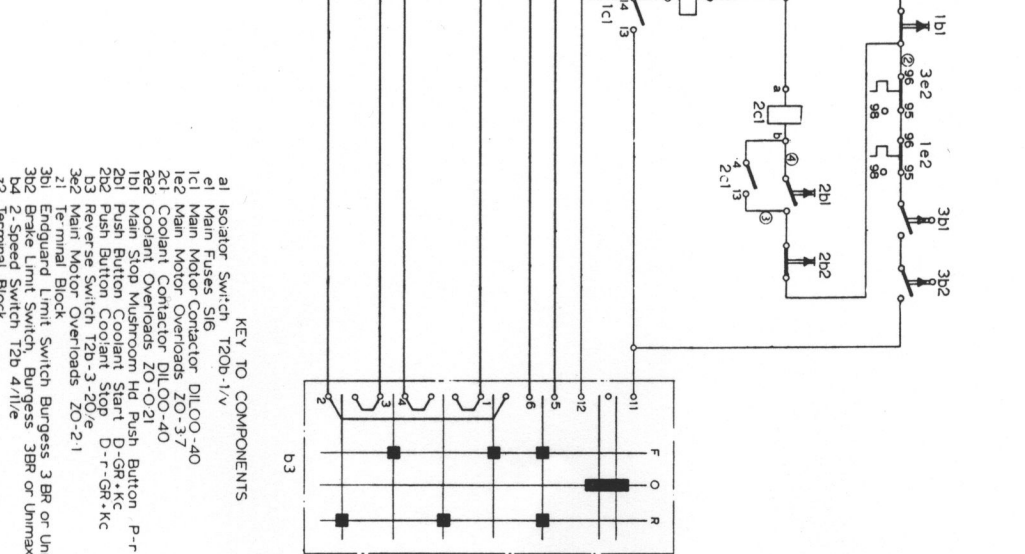
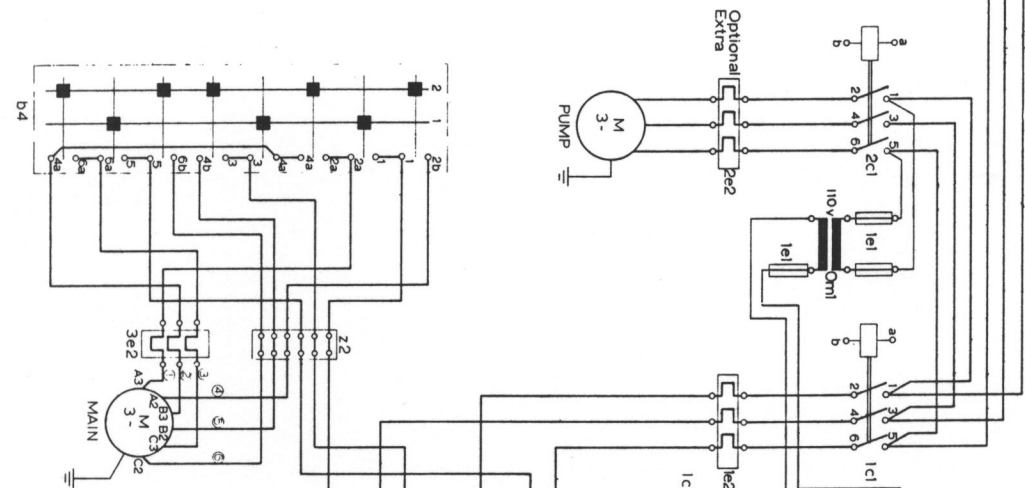
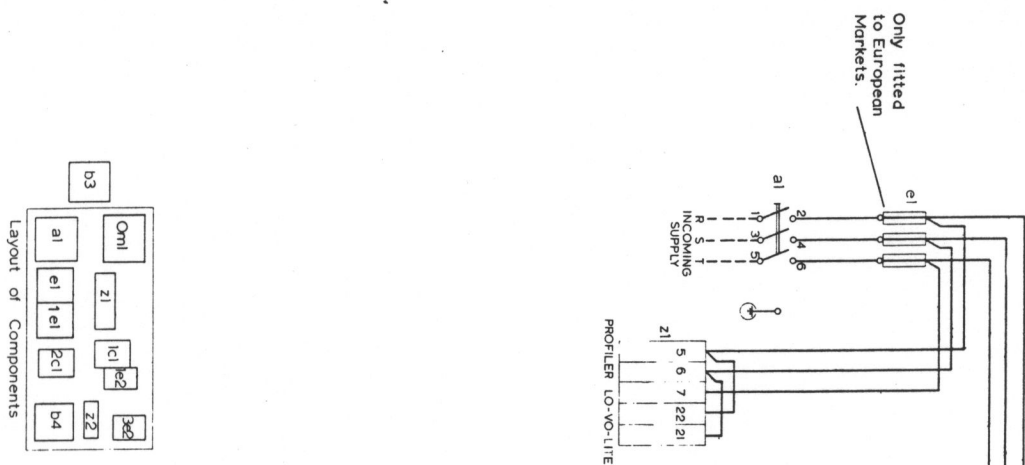

- KEY TO COMPONENTS**
- a1 Isolator Switch T20b-1/v
 - e1 Main Fuses S16
 - 1c1 Main Motor Contactor DILCOO-40
 - 1e2 Main Motor Overloads ZO-3/7
 - 2c1 Coolant Contactor DILCOO-40
 - 2e2 Coolant Overloads ZO-O/21
 - 1b1 Main Stop Mushroom Hd Push Button P-r-IP85-Kc
 - 2b1 Push Button Coolant Start D-GR-Kc
 - 2b2 Push Button Coolant Stop D-GR-Kc
 - b3 Repetitive Switch T20b-1/v
 - 3e2 Main Motor Overloads ZO-2-1
 - z1 Terminal Block
 - 3b1 Endguard Limit Switch Burgess 3 BR or Unimax 2HBU-1
 - 3b2 Brake Limit Switch, Burgess 3BR or Unimax 2HBU-1
 - b4 2-Speed Switch T2b 4/1/v
 - z2 Terminal Block
 - 1e1 Control Fuses S16
 - Om1 Control Transformer

WIRING DIAGRAM, 500V 3ph 50Hz, 3wire 2 SPEED, 110V, Control Circuit.

**WIRING DIAGRAM, 208V/230V, 460V, 575V,
SINGLE SPEED, CSA, 3PH, 60Hz.**

Wiring Notes
 Power - 14 awg Black
 Control - 16 awg Red
 Grounding wire - 14 awg Green
 All wires CSA approved

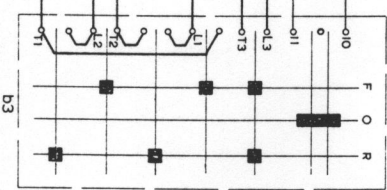
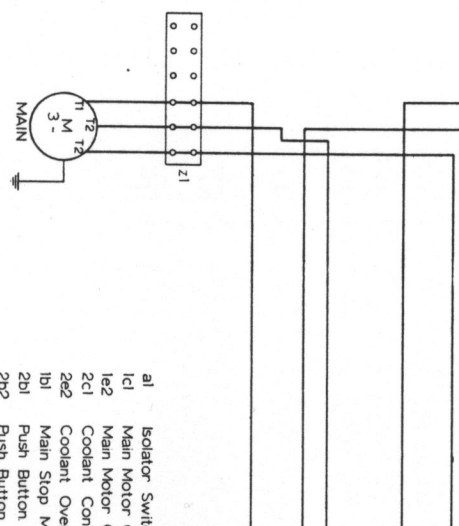
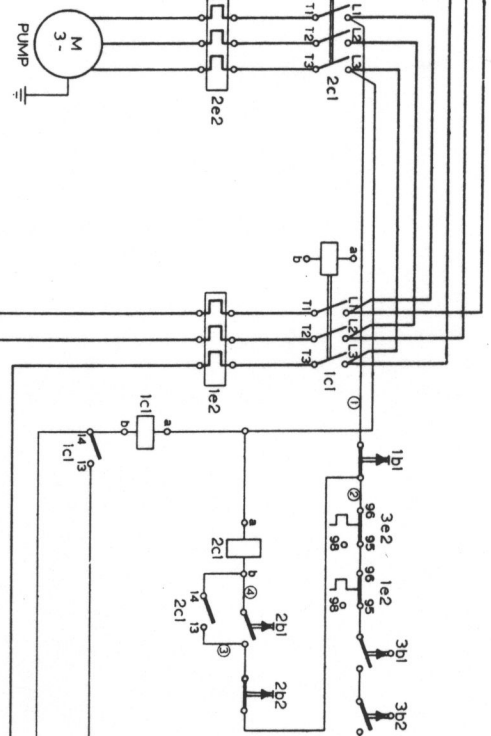
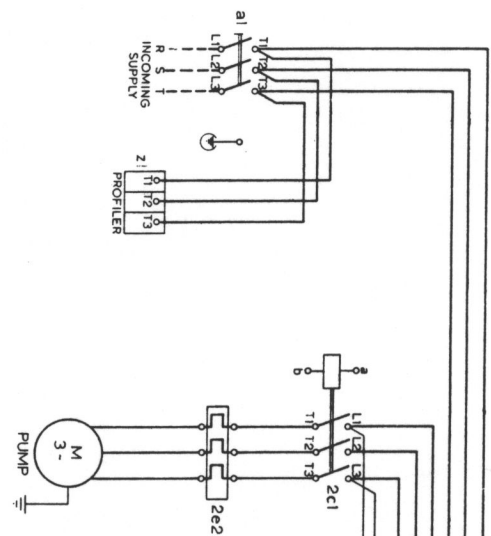
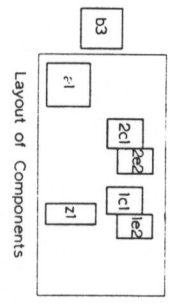

- KEY TO COMPONENTS**
- a1 Isolator Switch T20B-11/V Form CDN
 - 1c1 Main Motor Contactor DIL00B-40-NA
 - 1e2 Main Motor Overloads
 - 2c1 Coolant Contactor DIL00B-40-NA
 - 2e2 Coolant Overloads ZO-0-21 CNA
 - 1b1 Main Stop Mushroom Hd Push Button P-r-1P65-KC-NA
 - 2b1 Push Button Coolant Start D-GR-KC-NA
 - 2b2 Push Button Coolant Stop D-r-GR-KC-NA
 - b3 Reverse Switch T2b-3-20/e Form CDN
 - z1 Terminal Block Klippox SAK 2.5 CSA Approved
 - 3b1 Endguard Limit Switch Burgess 3BR or Unimax 2HB-1 CSA Appr'd
 - 3b2 Brake Limit Switch Burgess 3BR or Unimax 2HB-1 CSA Approved

Main Motor Overloads	
Volts	Overloads
208 volts	ZO-37-CNA
230 volts	ZO-37-CNA
460 volts	ZO-21-CNA
575 volts	ZO-21-CNA

WIRING DIAGRAM 208V, 230V, 460V, 575V,
2 SPEED, CSA, 3ph, 60hz.

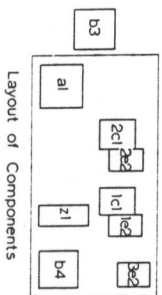

Layout of Components

Wiring Notes:
Power - 14 awg Black
Control - 16 awg Red
Grounding wire - 14 awg Green
All wires CSA approved

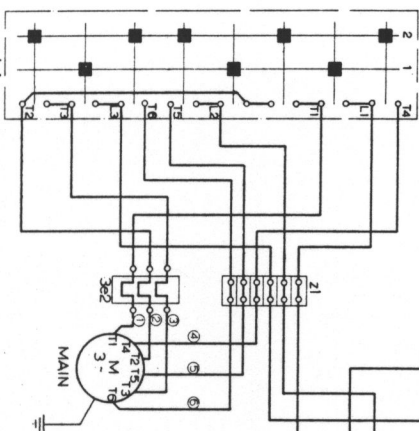
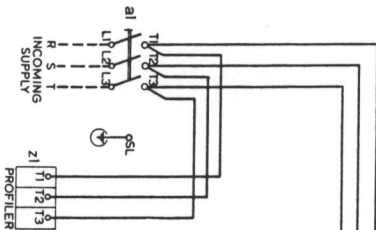

Main Motor Overloads

	Voltages	
1e2	208 volts	230 volts
2hp	ZO-6-7-CNA	ZO-6-7-CNA
3c2	ZO-3-7-K-NA	ZO-3-7-K-NA
	460 volts	575 volts
	ZO-3-7-CNA	ZO-3-7-CNA
	ZO-2-1-K-NA	ZO-2-1-K-NA

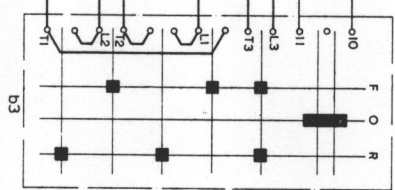
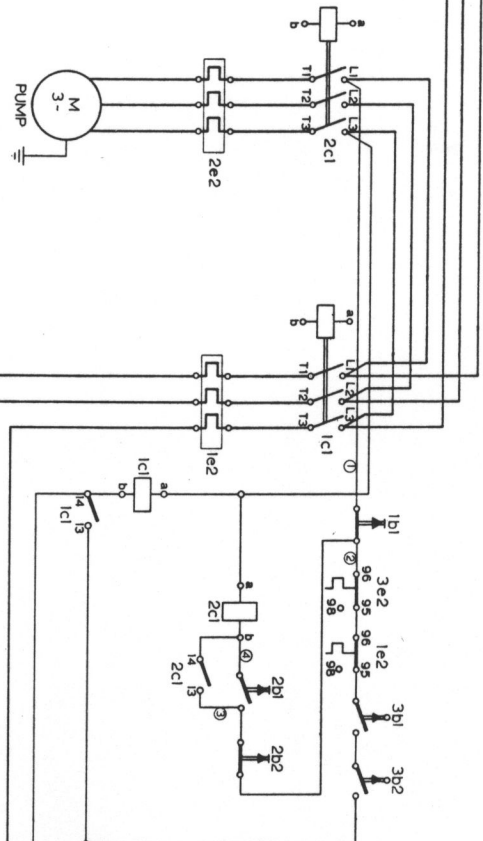

- KEY TO COMPONENTS
- a1 Isolator Switch T20b-1/v Form CDN
 - ic1 Main Motor Contactor DILCOob-40-NA
 - ie2 Main Motor Overloads
 - 3e2 Main Motor Overloads
 - 2c1 Coolant Contactor DILCOob-40-NA
 - 2e2 Coolant Overloads ZO-0-21 CNA
 - 1b1 Main Stop Mushroom Hd Push Button P-r-1P65-Kc-NA
 - 2b1 Push Button Coolant Start D-GR-Kc-NA
 - 2b2 Push Button Coolant Stop D-r-GR-Kc-NA
 - b3 Reverse Switch T2b-3-20/e Form CDN
 - b4 2 Speed Switch T2b-4-11/e Form CDN
 - z1 Terminal Block Klippox SAK 2.5 CSA Approved
 - 3b1 Endguard Limit Switch Burgess 3BR or Umimax 2HB1-1 CSA Approved
 - 3b2 Brake Limit Switch Burgess 3BR or Umimax 2HB1-1 CSA Approved

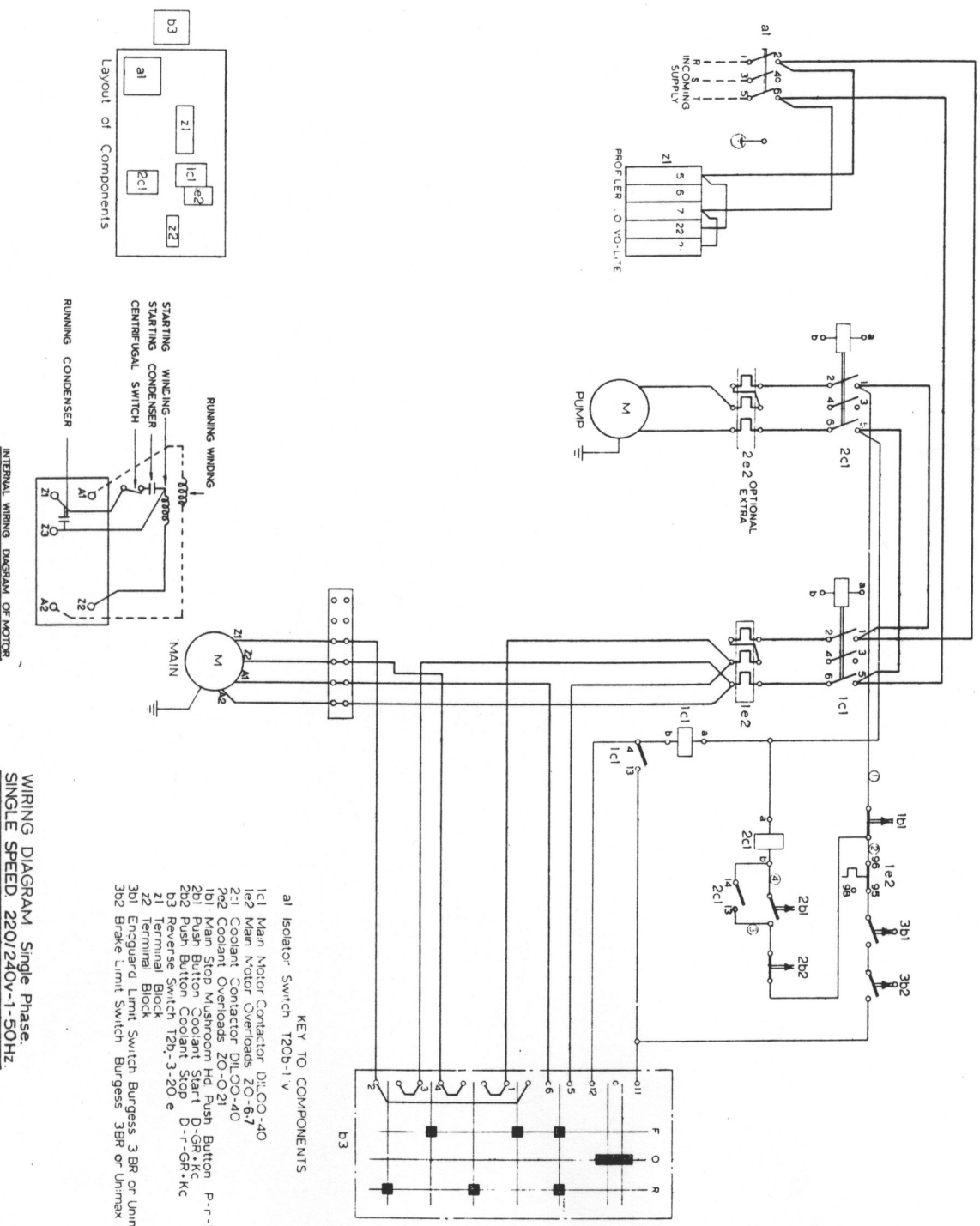

WIRING DIAGRAM, Single Phase, SINGLE SPEED, 220/240V-1-50Hz.

- KEY TO COMPONENTS
- a1 Isolator Switch 120b-1 V
 - 1c1 Main Motor Contactor D1LOQ-40
 - 1e2 Main Motor Overloads ZO-67
 - 2c2 Coolant Contactor D1LOQ-40
 - 2p1 Main Stop Push Button P-r-1965-KC
 - 2p2 Push Button Coolant Start D-69-KC
 - 3p1 Encoguard Limit Switch Burgess 3BR or Unimax 2HBU-1
 - 3p2 Brake Limit Switch Burgess 3BR or Unimax 2HBU-1
 - z1 Terminal Block
 - z2 Terminal Block
 - b3 Encoguard Limit Switch Burgess 3BR or Unimax 2HBU-1

CHUCK MOUNTING

The American type D1-3 in. Camlock spindle nose has been selected to overcome the danger of chucks or faceplates becoming detached whilst rotating.

The open or unclamped position is indicated when the datum line on the cam is in line with the vertical datum on the spindle nose.

The closed or clamped position is indicated when the datum line on the cam comes between the two arrows on the spindle nose.

To ensure that each spindle nose cam is fully secured in order to obtain maximum grip, it may be necessary to re-set the camlock studs in any new accessories which are to be mounted on the spindle nose.

To do this remove the cap head screws locking the studs and set each stud so that the scribed datum lines are as close to the rear face of the accessory as possible, without being below the surface, with the grooves lining up with the locking screw holes. Mount the accessory on the spindle nose and tighten the three camlocks in turn. These should be fully tightened when the datum line on the camlock is between the two arrows on the spindle nose. If any of the camlocks do not tighten within the limits of the arrows remove the accessory and turn the stud concerned through 360° in a clockwise direction. (This will bring the scribed line on the stud below the rear face of the accessory.) Re-mount and check the locking action again and repeat the above procedure until all three camlocks tighten within the limiting arrows. Finally, replace the locking screws beside each stud.

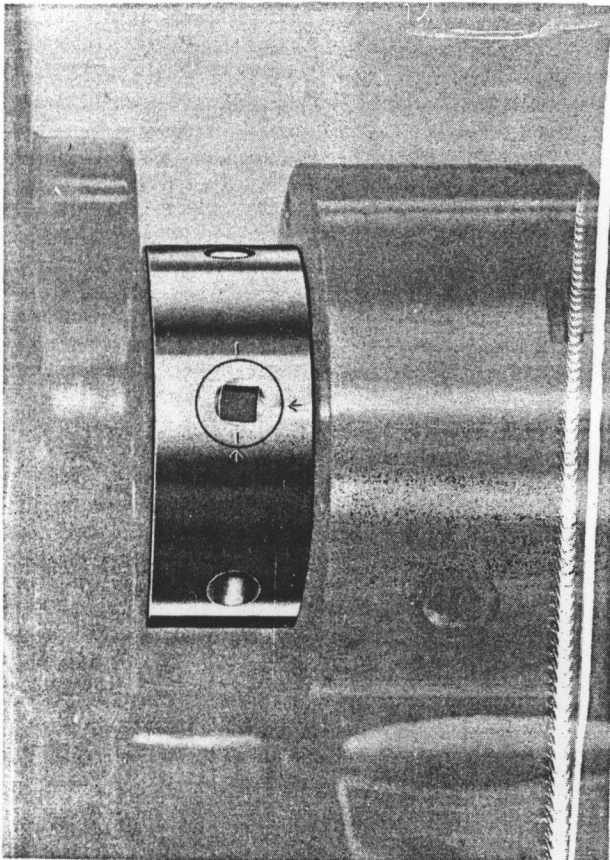

ALIGNMENT CHECKS

When the machine has been completely installed it is advisable to check the alignment of the headstock and tailstock. All machines are accurately aligned before despatch but transit shocks may necessitate adjustments.

HEADSTOCK ALIGNMENT TEST

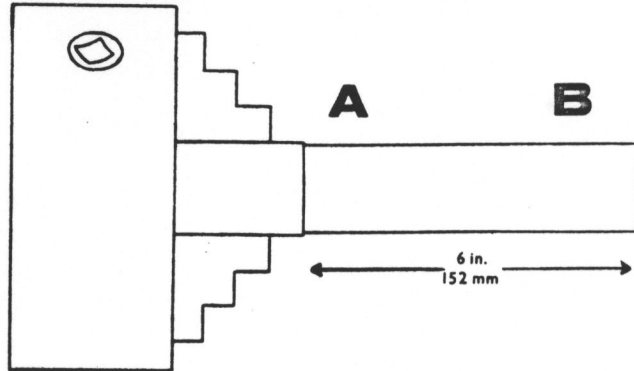

Headstock Alignment:

Place a length of mild steel bar in the chuck and take a light cut over the o.d. for about 6 in. of its length (Do not use the tailstock centre as a steady during this test). Micrometer readings at the two ends of the turned diameter (A and B in the sketch) should be the same. If the readings differ the head stock may easily be re-aligned as follows:

Slacken off the headstock holding down bolts (1) until they are only finger tight, which will allow the headstock to pivot round the locating dowel (2). A light tap with the palm of the hand in the required direction is all that is necessary to affect an adjustment. As a guide, with a dial indicator set against point B of the test piece it will be necessary to swing the headstock approximately 2½ times the difference in micrometer readings between point A and point B. It is important that if any adjustments have been made, all holding-down bolts are securely tightened.

TAILSTOCK ALIGNMENT TEST

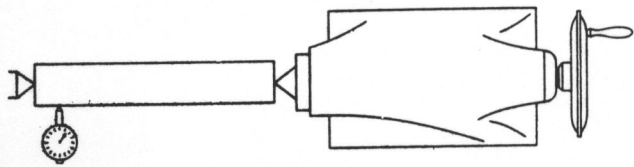

Tailstock Alignment:

Place a 12 in. long ground steel bar between centres. Fix a dial gauge to the topslide with its anvil running along the horizontal centre line of the bar. By traversing the saddle along the bed an accurate check on alignments may be made. If any error is found it may be rectified by adjustment of the two set-over screws in the base of the tailstock.

ADJUSTING HEADSTOCK ALIGNMENT

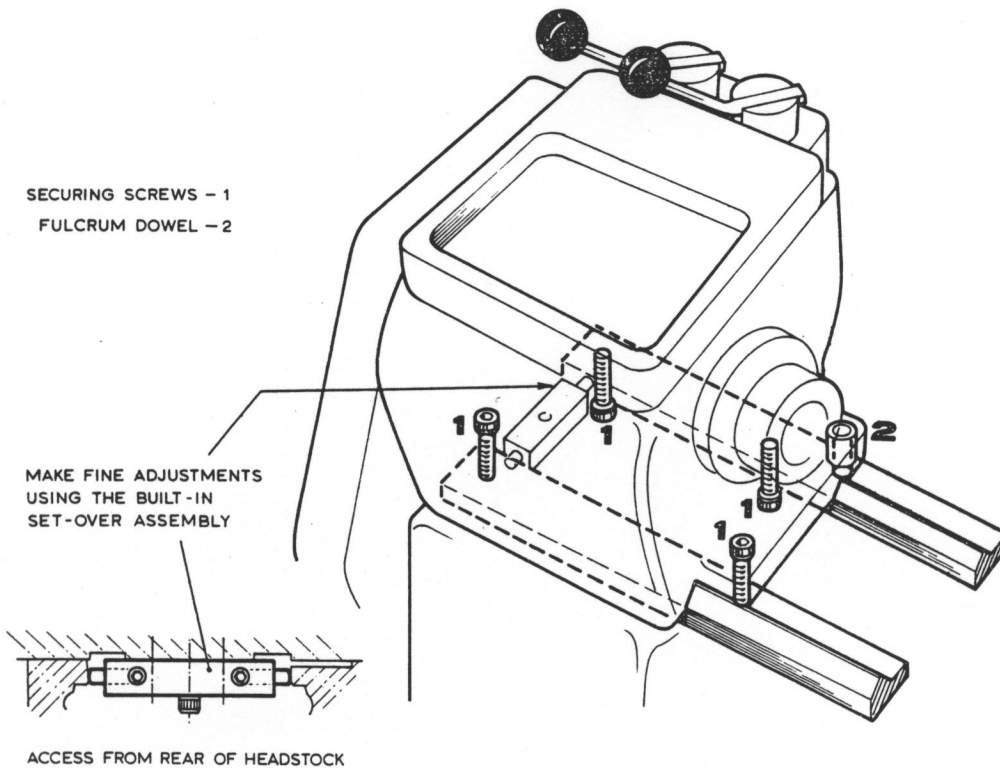

LUBRICATION

The accuracy and life of the machine depend on correct lubrication. All oiling points should be properly lubricated and the oil levels of the headstock and gearbox checked before the machine is used.

The lubrication chart gives information on the points which need periodic attention and it cannot be stressed too strongly that all points marked with a black diamond should receive daily attention to ensure efficient operation.

When carrying out the weekly check on the headstock and gearbox always stop the machine to allow the oil to settle so that a true reading is obtained. If this precaution is not taken there is a risk of over-filling which will result in the generation of excessive heat and the loss of oil by leakage.

After the machine has been in operation for 160 hours or four weeks—whichever is the sooner—the headstock and gearbox should be drained, flushed with clean flushing oil and re-filled to the correct level with the appropriate grade of oil. This procedure should be repeated every 500 hours or 3 months—whichever is sooner.

When the machine is despatched from the works the headstock and gearbox are filled with Shell Tellus Oil 27. Tellus oils may be obtained from Shell Oil Companies throughout the world but in case difficulty is experienced in obtaining this particular grade the physical properties are given below:

Specific Gravity at 60°F	0.870
Flash point closed	390°F
Pour point	- 20°F
Viscosity	
Redwood No. 1:	
70°F	310 secs
140°F	68 secs
200°F	41 secs

THE USE OF AN INCORRECT GRADE OF OIL IS LIABLE TO CAUSE OVERHEATING AND POSSIBLE DAMAGE.

The bearings of the pump motor (where this is supplied) should also be greased periodically and for this application we recommend Shell Alvania 3 Grease.

The motor bearings should also occasionally be checked to ensure that they have an adequate supply of the grade of grease recommended by the manufacturer.



LUBRICATION CHART

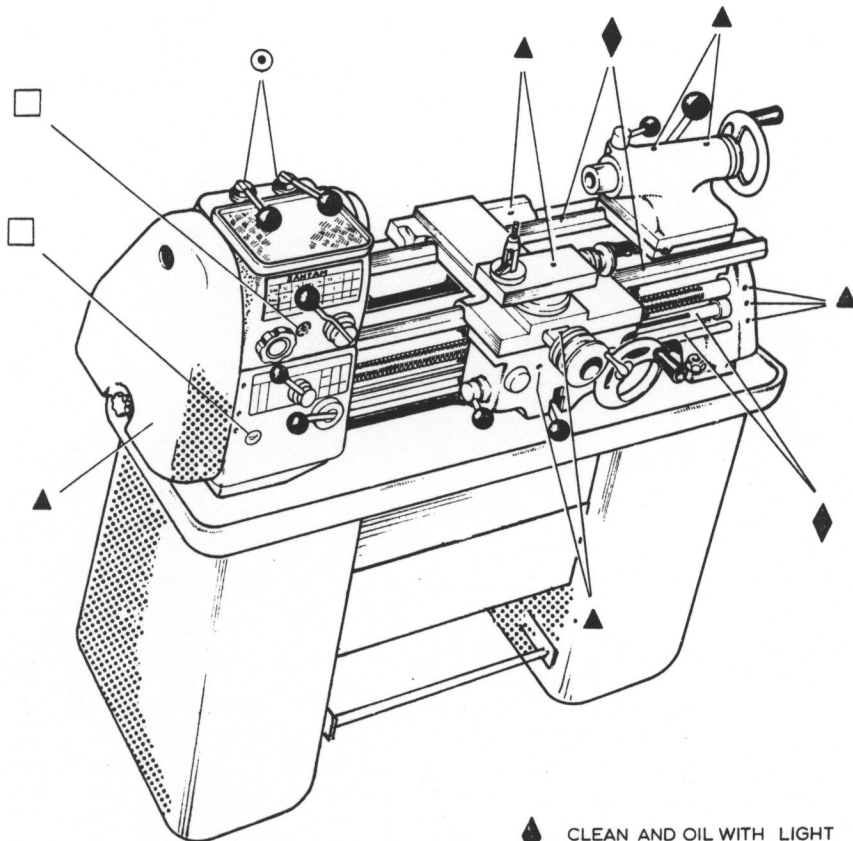

◆ CLEAN AND OIL WITH LIGHT OIL EACH DAY

▲ OIL ONCE PER WEEK WITH LIGHT OIL

□ TOP UP WITH RECOMMENDED OIL EACH WEEK

○ LIGHTLY OIL WHEN NEEDED

OPERATION

STARTING

The lathe motor is started through a two-position isolator switch on the front of the cabinet.

Spindle rotation is then controlled by a hand lever at right-hand side of the apron; lift the lever for Forward rotation, depress the lever fully for Reverse rotation. A neutral position is provided to stop spindle rotation.

Stop the lathe motor by turning the two-position switch on the front of the cabinet. An emergency Red mushroom-head stop button is provided at the left-hand side of the front panel.

When a two-speed motor is fitted, the control switch is included on the cabinet front panel; at the right-hand side.

A spindle brake is mechanically operated through the foot pedal between the plinths.

Coolant supply is controlled by the ON/OFF push buttons below the Red emergency stop button.

levers will not seat correctly and no attempt should be made to rotate the spindle under power.

The hand-knob (4) at front of the headstock operates reversing mechanism for the leadscrew and feedshaft.







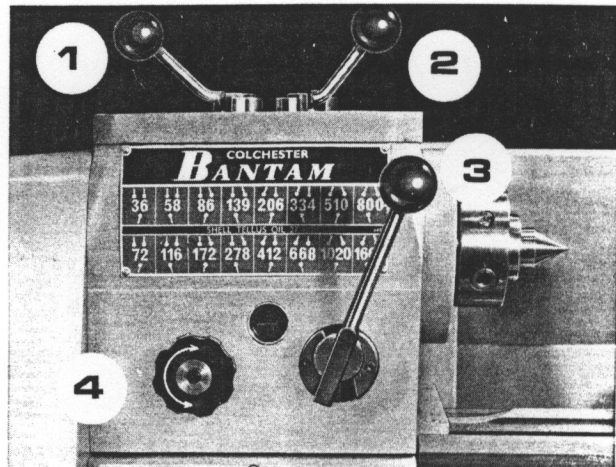









SPINDLE AND HEADSTOCK GEARING MUST BE STOPPED BEFORE MOVING ANY OF THESE CONTROLS.

HEADSTOCK — SPEED SELECTION

































The chart at the front of the headstock (reproduced below) shows positions for two top-mounted control levers (1 and 2) and the front mounted lever (3) for spindle speeds required. These levers have spring-loaded action and safety-gate location. Until selected gearing is fully in mesh, the



**SINGLE
SPEED**

 36 	 58 	 86 	 139 	 206 	 334 	 510 	 800 
SHELL TELLUS OIL 27							

**TWO
SPEED**

 36 	 58 	 86 	 139 	 206 	 334 	 510 	 800 
SHELL TELLUS OIL 27							
 72 	 116 	 172 	 278 	 412 	 668 	 1020 	 1600 

DRIVE

Drive to the headstock from the motor is by vee belt. The motor platform is adjustable to allow for the correct tensioning of the belt which should have approximately $\frac{3}{4}$ in. (19 mm) free side movement in either direction under light pressure.

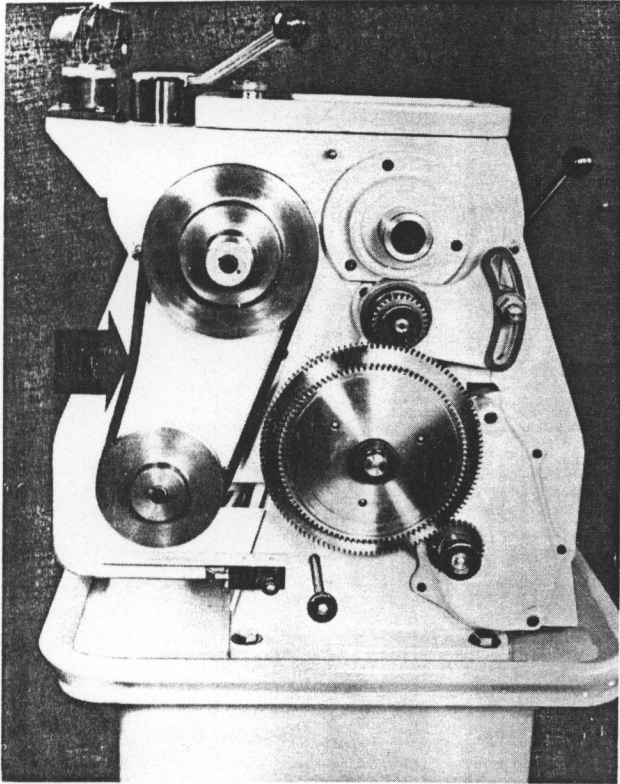

SWING FRAME ASSEMBLY

The drive from the headstock to the gearbox is transmitted through the end train of gears.

These are fitted to a swing frame which is readily adjusted to accommodate up to a 60T/16DP gear in the driving position up to a 100T/16DP gear in the driven position (127T/16DP on the non-gearbox model).

A shear pin device is fitted as a precautionary measure to protect the leadscrew against overload in the low speed range. A broken pin can easily be replaced by removing the top gear in the end train and then the splined sleeve which carries the gear. The broken pin can then be tapped out of the sleeve. To remove the remainder of the pin rotate the shaft until the pin hole is opposite the slot in the housing. This can now be knocked through and will drop out through the slot. A new pin may now be fitted and the change gear sleeve re-assembled.

When the end guard is opened the electrics are isolated by a micro-switch.

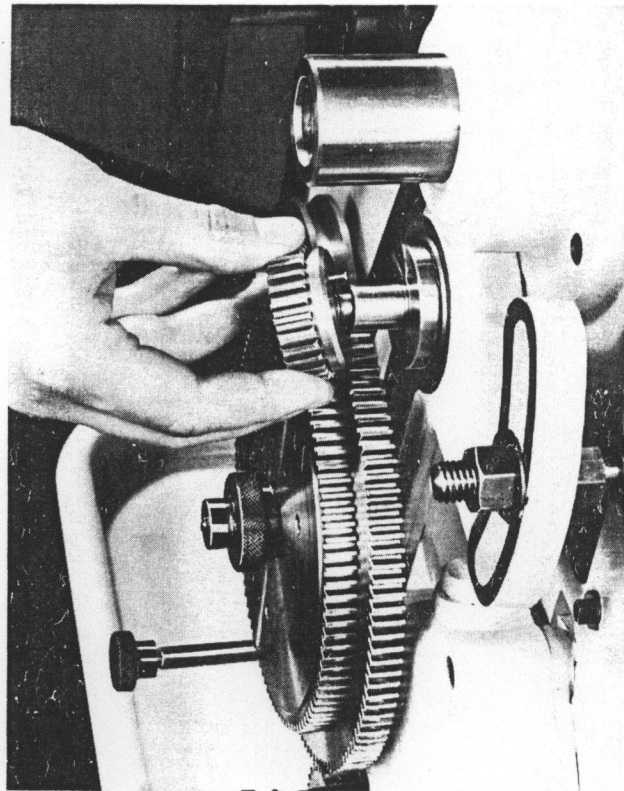

GEARBOX

Two alternative types of quick change gearbox may be fitted.



Control of both gearboxes is by two levers as illustrated, lever No. 1 having three positions and lever No. 2 having six positions. By manipulating these levers and fitting the correct change wheels as shown on the nameplate, the full range of threads and feeds are obtained.

The knob situated on the front of the headstock controls the direction of feed, reversing it as



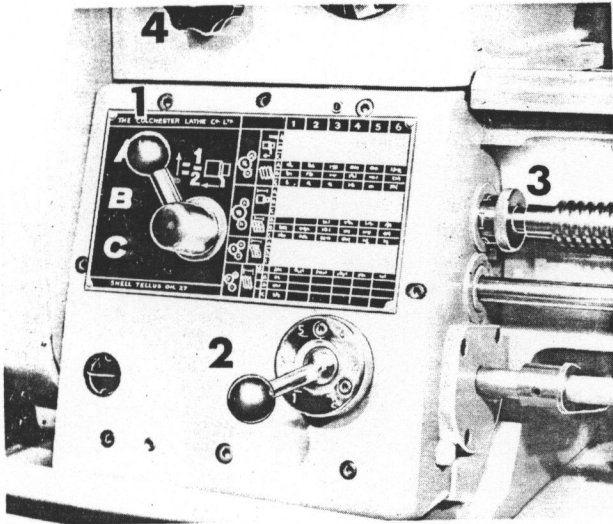







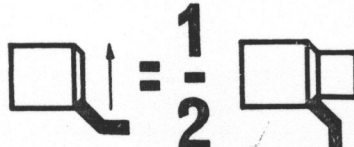
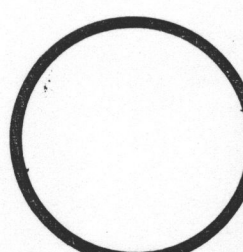
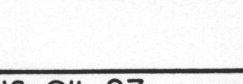







necessary, and a dog clutch (No. 3) is provided so that the leadscrew may be disengaged as this should not be allowed to revolve except when screwcutting.

THE SPINDLE AND HEADSTOCK GEARING MUST BE STOPPED BEFORE ANY OF THE LEVERS CONTROLLING THE GEARBOX ARE MOVED.



		M.M. 127		M.M. 127			
							
		X	Y	X	Y		
0.5	A1	35	60	2.0	B1	35	30
0.6	A3	35	60	2.5	B5	35	36
0.75	A5	35	60	3.0	B5	35	30
1.0	A1	35	30	3.5	B5	49	36
1.2	A3	35	30	4.0	C1	35	30
1.25	A5	35	36	5.0	C5	35	36
1.5	A5	35	30	6.0	C5	35	30
1.75	A5	49	36				

SHELL TELLUS OIL 27

THE COLCHESTER LATHE CO. LTD.				1	2	3	4	5	6
<div style="display: flex; flex-direction: column; align-items: center;"> <div style="margin-bottom: 20px;"> <p>A</p>  </div> <div style="margin-bottom: 20px;"> <p>B</p>  </div> <div> <p>C</p>  </div> </div>	  	INS.	A		.005		.006		.008
			B		.010		.012		.016
			C		.020		.025		.032
			A	24	22	20	18	16	14
			B	12	11	10	9	8	7
			C	6		5	4.5	4	3.5
	   	INS.	A	.001		.001			.002
			B	.002		.003			.004
			C	.005		.006			.008
			A			80	72	64	56
			B	48	44	40	36	32	28
			C	24	22	20	18	16	14
  		A	48	44	40	36	32	28	
		B	24	22	20	18	16	14	
		C	12	11	10	9	8	7	
  		X		1	2	3	4	5	6
		39 A	26						
		57 B	19						
			C						

SHELL TELLUS OIL 27 0472

THREAD CUTTING WITH ENGLISH GEARBOX FITTED TO BANTAM EAGLE

1. Threads available from the gearbox

The screwcutting dial on the front face of the apron has four numbered divisions and four sub-divisions. To cut an even number of threads—i.e., 12 t.p.i.—the leadscrew may be engaged at any division. For odd numbered threads—i.e., 13 t.p.i.—the leadscrew may be engaged at any numbered division, and for fractional threads—i.e., 11½ t.p.i.—the leadscrew must be engaged at the same mark at each pass.

2. Threads not available from the gearbox

To cut threads which are not available from the gearbox, it may be necessary to use special change gears which are available as extra equipment. To obtain the number of teeth in these gears, the following formulae should be used.

English threads

$$\frac{7 \times Z}{3 \times Y \times \text{T.P.I.}} = \frac{\text{Driver}}{\text{Driven}}$$

Where Y = 1 for lever position A
 2 for lever position B
 4 for lever position C
 and Z = 12 with lever in position 1
 11 " " " " 2
 10 " " " " 3
 9 " " " " 4
 8 " " " " 5
 7 " " " " 6

Example:

It is required to cut 26 t.p.i. With lever Z in position 1 and lever Y in position A.

$$\text{Then: } \frac{7 \times 12}{3 \times 1 \times 26} = \frac{14}{13} = \frac{42}{39} \frac{\text{Driver}}{\text{Driven}}$$

D.P. Threads

$$\frac{22 \times Z}{3 \times Y \times \text{D.P.}} = \frac{\text{Driver}}{\text{Driven}}$$

Where Z and Y have the same values as for English threads.

Example:

It is required to cut 16 D.P. With lever Z in position 5 and lever Y in position B.

$$\text{Then: } \frac{22 \times 8}{3 \times 2 \times 16} = \frac{11}{6} = \frac{55}{30} \frac{\text{Driver}}{\text{Driven}}$$

Metric thread pitches

$$\frac{7 \times P \times Z}{72 \times Y} = \frac{\text{Driver}}{\text{Driven}} \times \frac{120}{127} \text{ (Compounded idler)}$$

Where P = pitch in millimetres to be cut and Z and Y have the same values as for English threads. The result will be compounded with 120 change gears thus:

$$\frac{120}{127}$$

Example:

It is required to cut a 3 mm pitch. With lever Z in position 5 and lever Y in position B.

$$\text{Then: } \frac{7 \times 3 \times 8}{72 \times 2} = \frac{7}{6} = \frac{35}{30} \times \frac{120}{127}$$

This is fitted to the swing frame thus:

$$\frac{35}{127} \times \frac{120}{30}$$

NOTE

When cutting metric thread pitches, the leadscrew halfnut should be engaged when thread cutting is commenced, and should not be disengaged until the thread is completed.

3. Multi Start Threads.

Multi start threads may be cut in any one of three ways:

1. By repositioning the compound slide one pitch forward for each start. It will be realised however that the accuracy of this method depends upon the operator.
2. By using an accurately divided driver plate and turning the workpiece one division forward for each start.
3. By advancing the driver gear a calculated number of teeth to advance the spindle by one pitch of the thread to be cut. The accuracy of this method is that of the machine. In order to use this method a driver wheel should be used in which the number of teeth is a factor of the number of starts to be cut.

Example:

To cut a 6 start thread with 36T gear in the driver position:—

- (i) Cut one start.
Dividing 6 into 36 gives 6 which is the number of teeth to move the driver gear to obtain each subsequent start.
- (ii) Mark the meshing tooth on all gears, then remove the idler gear.
- (iii) Turn the driver gear through the calculated number of teeth and replace the idler gear, making sure that the meshing marks on the idler and driven gears correspond exactly.
- (iv) Cut the next start and repeat for each remaining start.

THREAD CUTTING WITH CONTINENTAL GEARBOX FITTED TO BANTAM CONDOR

1. Threads available from the gearbox

When cutting metric, module and English thread pitches, the nut must be closed over the leadscrew and not released until the thread is completed. After each pass and tool withdrawal, the machine should be reversed by means of the reversing switch until the tool has returned to the correct position for the next pass.

Setting the machine for thread cutting is accomplished by fitting the appropriate change wheels and selecting the correct positions for the gearbox levers. The correct settings may be readily ascertained by referring to the thread plate.

	1"		1"		0.448		MM		
	X	Y	X	Y	X	Y			
35 A1	60	45	20 C1	28	30	0.3 C1	1.25 C3		
4 A1	35	30	22 B5	35	55	0.4 B5	1.5 C1		
5 A1	28	30	24 C5	35	30	0.5 B3	1.75 B6		
6 A5	35	30	28 B5	30	60	0.6 B1	2.0 B5		
7 B1	60	45	32 B6	30	60	0.7 A6	2.25 B4		
8 B1	35	30	36 C5	35	45	0.8 A5	2.5 B3		
9 A5	35	45	40 B6	30	75	0.9 A4	2.75 B2		
10 B1	28	30	44 C5	35	55	1.0 A3	3.0 B1		
11 A5	35	55	48 C5	35	60		3.5 A6		
12 B5	35	30	56 C5	30	60		4.0 A5		
14 C1	60	45	60 C5	35	75		4.5 A4		
16 C1	35	30	64 C6	30	60		5.0 A3		
18 B5	35	45	80 C6	30	75		5.5 A2		
							6.0 A1		
	127 		127 		120 		120 		
SHELL TELLUS OIL 27									

THE COLCHESTER LATHE CO. LTD.		1	2	3	4	5	6
<p>A </p> <p>B </p> <p>C </p>	M.M.	A 0.35		0.30			0.20
	B 0.20		0.15				0.10
	C 0.10		0.07				0.05
	M.M.	A 3.0		2.5		2.0	1.5
	B 1.5		1.25		1.0		
	C 0.75				0.5		
	M.M.	A 0.70		0.60			0.40
	B 0.40		0.30			0.20	
	C 0.20		0.15			0.10	
	M.M.	A 6.0	5.5	5.0	4.5	4.0	3.5
	B 3.0		2.5		2.0	1.75	
	C 1.5		1.25		1.0		
M.M.	A 0.15		0.12			0.08	
B 0.07		0.06				0.04	
C 0.04		0.03				0.02	
M.M.	A 1.2	1.1	1.0	0.9	0.8	0.7	
B 0.6		0.5	0.45	0.4	0.35		
C 0.3		0.25		0.2			
SHELL TELLUS OIL 27 0467		1	2	3	4	5	6

2. Threads not available from the gearbox

To cut threads which are not available from the gearbox it may be necessary to use special change gears which are available as extra equipment. To obtain the number of teeth in these gears, the following formulae should be used.

Metric thread pitches

$$\frac{28 \times P}{3 \times Z \times Y} = \frac{\text{Driver}}{\text{Driven}}$$

Where P = pitch to be cut.

Y = 4 for lever position A.

2 " " " B.

1 " " " C.

and Z = 12 with lever in position 1

11 " " " " 2

10 " " " " 3

9 " " " " 4

8 " " " " 5

7 " " " " 6

Example:

It is required to cut a .75 mm pitch. With lever Z in position 1 and lever Y in position C.

$$\text{Then: } \frac{28 \times .75}{3 \times 12 \times 1} = \frac{7}{12} = \frac{35}{60} \frac{\text{Driver}}{\text{Driven}}$$

Module pitches

$$\frac{88 \times M}{3 \times Z \times Y} = \frac{\text{Driver}}{\text{Driven}}$$

Where Z and Y have the same values as for metric pitches.

Example:

It is required to cut a pitch of 2 mod. With lever Z in position 5 and lever Y in position B.

$$\text{Then: } \frac{88 \times 2}{3 \times 8 \times 2} = \frac{11}{3} = \frac{66}{18} \frac{\text{Driver}}{\text{Driven}}$$

As this cannot be accommodated on the swing frame it is necessary to compound the train thus:

$$\frac{55}{18} \times \frac{120}{100}$$

English threads

$$\frac{224}{Z \times Y \times \text{t.p.i.}} = \frac{\text{Driver}}{\text{Driven}} \times \frac{127}{120} \text{ (Compounded idler gear)}$$

Where Z and Y have the same values as for metric pitches.

Example:

It is required to cut 10 T.P.I. With lever Z in position 1 and lever Y in position B.

$$\text{Then: } \frac{224}{12 \times 2 \times 10} = \frac{28}{30}$$

The result will be compounded with $\frac{127}{120}$ change gears thus:

$$\frac{28}{30} \times \frac{127}{120}$$

and is fitted to the swing frame thus:

$$\frac{28}{120} \times \frac{127}{30}$$

When using any of the above formulae for both English and Continental gearboxes there is no set rule as to the lever positions to be used. It is normal, however, to use lever positions which give a standard thread or pitch through the gearbox which is close to the special thread or pitch required where possible.

Multi Start Threads

These may be cut in exactly the same way as previously described for the English gearbox.

NOTE. Whichever method is used, the leadnut should be engaged to cut the first thread and not released until all starts have been completed.

APRON

Surfacing and sliding feeds are selected by a plunger (1). Surfacing feeds are obtained with the plunger fully extended and sliding feeds with the plunger fully depressed. The feeds are engaged by lever (2) which incorporates a safety device to prevent overloading. This device also allows the use of feed stops which automatically disengage the feed mechanism on contact with a pre-set limit stop.

When screw cutting the lead nut is controlled by lever (3).

The screw cutting and feed engagement levers are fully interlocked to prevent simultaneous engagement.

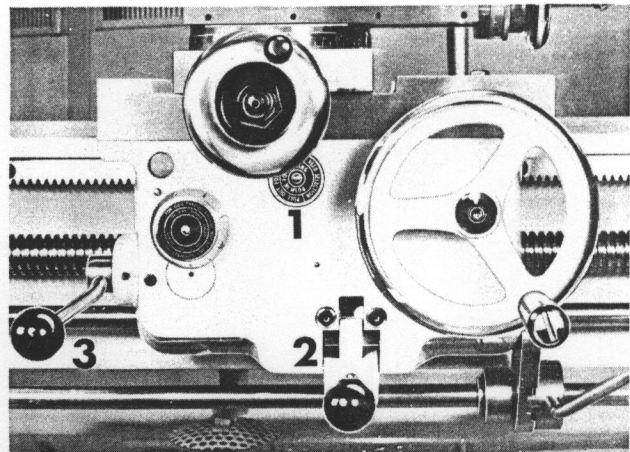

SADDLE AND SLIDES

The saddle is secured to the bed by adjustable gibs at the front and rear and can be locked on the bed in any position. The slides carry large diameter micrometer dials graduated in 0.001in or 0.02mm divisions. The compound slide is radially graduated $90^{\circ}-0^{\circ}-90^{\circ}$ each side for accurate setting. A front toolholder is fitted as standard equipment. As an alternative the Colchester quick change toolpost is available as additional equipment.

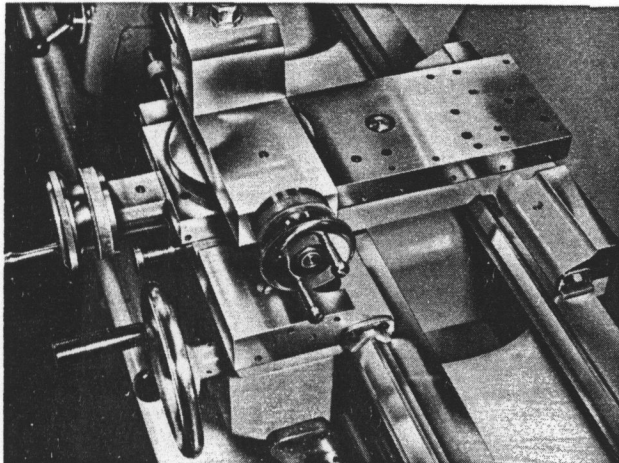

THE BED

The lathe bed should be cleaned down as often as possible by brushing to keep it free from cuttings. Do not use an air line, which will drive chips under the sliding surfaces and blow away the protecting oil film. After each cleaning the bed should be coated with Shell Tellus 27 oil to prevent rust formation.

THE TAILSTOCK

The barrel is graduated in inch and metric divisions and induction hardened both in the No. 3 morse taper bore and on the outside diameter. All standard tang drills are driven by the tang and eject at zero graduation. A tool height indicator line is stamped on to the front face of the nose chamfer to assist in setting tools to the correct centre height when a workpiece is being held between centres.

There are two parts to the tailstock casting, the base proper which slides along the bedways and the tailstock body which may be moved laterally on the base. This movement or "setting over" allows shallow tapers to be turned without the need of a special taper-turning attachment. The tailstock is set over by first releasing the bedway clamp lever and adjusting the two set-over screws fitted for this purpose. THE TWO SPRING-LOADED SHOULDER BOLTS HOLDING THE BASE TO THE MAIN CASTING DO NOT REQUIRE SLACKING OFF AT ANY TIME. Quick lever clamping is employed to lock the assembly in position on the bedways. The tailstock barrel is locked by a lever-operated clamp.

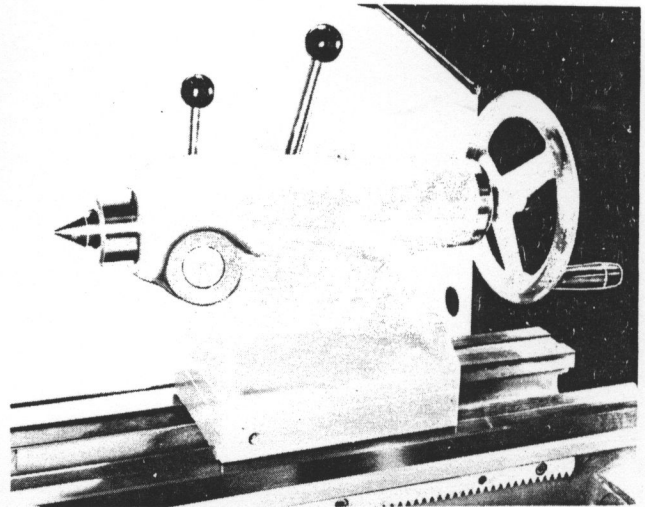

ACCESSORIES

A comprehensive range of accessories is available for the Colchester Bantam lathe, specifically designed for the machine and engineered for simplicity, robustness and reliability.

A brief list of these is given below and more detailed information on certain items is given in subsequent pages. All these accessories can be fitted to the machine after it has left the works.

5-station hand-operated inclined head capstan slide with adjustable rotating stops and maximum working stroke of $4\frac{1}{2}$ in. bored to receive $\frac{3}{4}$ in. dia. shank toolholder	661	Flexible round bore E Type collets for 'Multi-size' collet chuck: each having $\frac{1}{8}$ in. capacity in steps from $1/16$ in. to $1\frac{1}{2}$ in. Price each also suitable for hexagonal bore up to $1\frac{1}{4}$ in. AF	653
5-station capstan slide as above with maximum working stroke of 114 mm bored to receive 20 mm dia. shank toolholders	686	Jacobs type drill chuck with 3 M.T. arbor $0\frac{1}{2}$ in. capacity	622
Colchester type No. 259 quick change toolpost complete with 4 standard toolholders, 1 vee holder, 1 morse taper holder and 2 wrenches	671	Perspex chuck/chip guard for fitting to lathe bed or saddle	664
Additional standard toolholders No. 83116 for above	672	Single-type bed stop	697
Additional vee holders No. 83117 for above	673	Micrometer bed stop	695
Additional morse taper holders No. 83118 for above	674	5-position turret type bed stops for automatic cut-out on cross feeds	624
Rear toolposts	646	5-position turret type bed stops for automatic cut-out on longitudinal feeds	625
125 mm dia. Burnerd 3-jaw geared scroll D.I. Camlock chuck (no backplate required).	601	Electric coolant pump, tank and fittings	608
205 mm dia. Burnerd 4-jaw independent D.I. Camlock chuck (no backplate required).	602	3-point stationary steady $3\frac{1}{2}$ in. dia. capacity	609
Burnerd lever operated 'Multisize' collet chuck for direct mounting on spindle nose, complete with anchor bracket (for details of collets see Code Nos. 653, 665 and 666)	663	50 volt 48 watt low volt lighting for standard A.C. supply only	610
Burnerd $1\frac{1}{2}$ in. capacity key operated 'Multisize' collet chucks	652	Telescopic taper turning attachment	632
		G.M.T. type 3 RC/I No. 3 M.T. rotating centre	617

THE COOLANT SYSTEM

The coolant tank and pump unit is attached to the underside of the tray at the rear of the machine. A return pipe from the centre of the tray takes the coolant back to the tank and a gauze strainer is fitted to the pipe at tray level to ensure that no swarf is returned to the tank. The flexible piping supplied with this unit is fully universal and will feed coolant to any required position. The supply of coolant is easily controlled by the leakproof ball type shut-off valve. The whole unit has been designed to eliminate the leaks which are usually inherent in coolant systems.

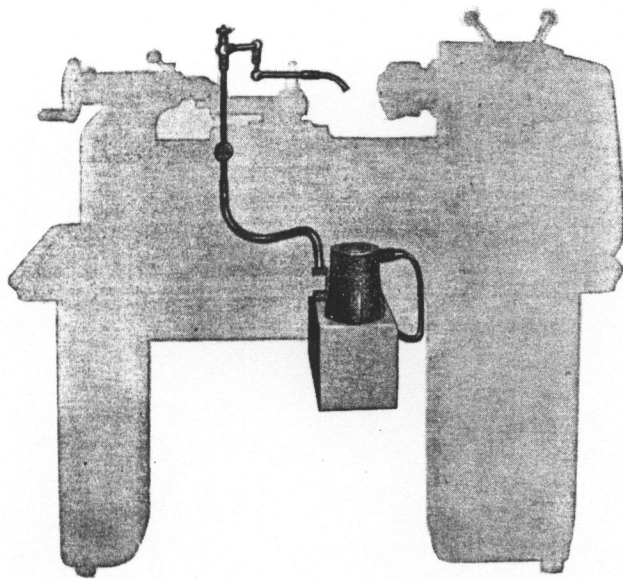

Soluble oil emulsions

For most work a soluble oil emulsion should be chosen since this will almost always be adequate for the work in hand and will be preferred by the machine operator. When screwing with a die head, tapping, or reaming, some extra coolant applied locally may be required. If much work of this type is contemplated, it may be better to use an emulsion of an extreme pressure soluble oil in the machine sump. A good quality oil of this type will give results equal to neat cutting oil whilst retaining the cleanliness of soluble oil.

Good quality soluble oil should always be chosen and mixed in accordance with the supplier's recommendations. The following grades have been tested and used in our own works with complete satisfaction:

Shell Dromus Oil B—conventional milky soluble oil mixed with water in the ratio 25/30:1.

Shell Dromus Oil D—translucent soluble oil mixed with water in the ratio 40:1.

Shell Dromus Oil 908—extreme pressure oil mixed with water in the ratio 10/15:1.

Soluble oils and machine maintenance

No soluble oil, however good, can completely prevent rust without help from the operator. The machine should therefore be cleaned down regularly and the bright parts wiped over with machine oil. It should never be left, especially over weekends or holidays, with wet swarf on the bed or slides. When the work in hand requires the saddle or slides to be clamped in position for long periods, it is advisable to spread a little machine oil on the bed beforehand to ensure a film of oil between the surfaces. The sump should be emptied, cleaned out and refilled with newly mixed soluble oil at regular intervals.

COLCHESTER QUICK CHANGE TOOLPOST

This type of toolpost may be fitted to existing standard slotted topslides without alteration. It enables any number of toolholders to be used and any lathe operation to be carried out. Designed to cut down time on repetition work, the Colchester Quick Change Toolpost is outstanding in its versatility and ease of use. It consists of a basic clamping head to which a variety of toolholders may be fitted.

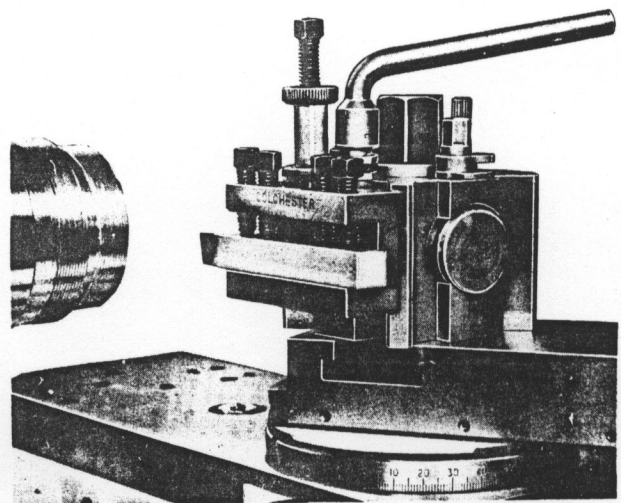

Each toolholder has a vertical adjusting screw and when a tool in its holder has been set to centre height it may be removed and replaced any number of times in the sure knowledge that the tool will be at exact centre height each time it is returned to the clamping head.

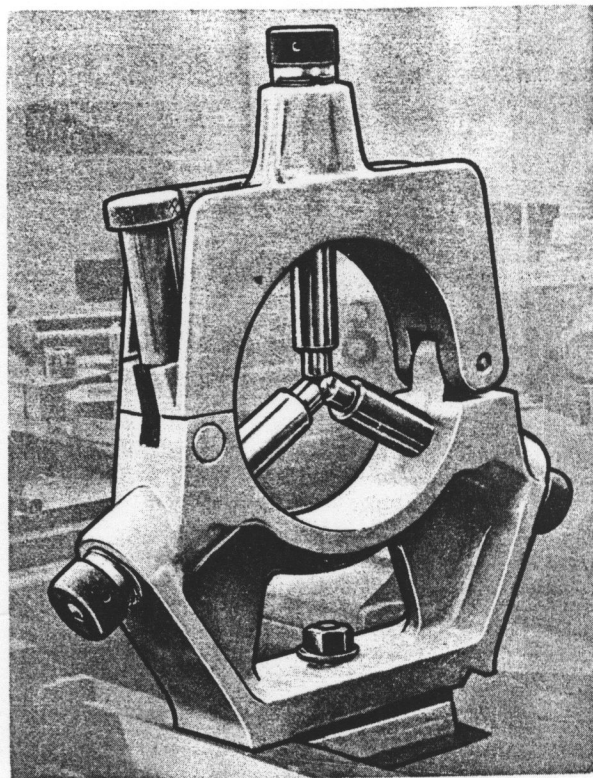
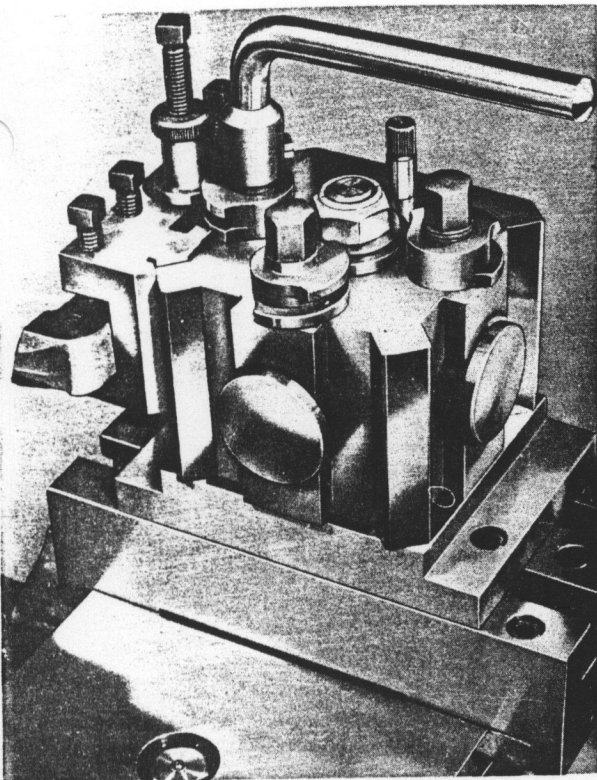

Three types of toolholder are available.

The standard toolholder will accommodate all normal types of tool up to a maximum size of $\frac{3}{4}$ in. x $\frac{1}{2}$ in. (19 mm x 12.5 mm). The vee toolholder will accommodate boring tools with parallel shanks up to $\frac{5}{8}$ in. (16 mm) diameter. A morse taper holder is also available suitable for all tools having a No. 1 M.T. shank.

STATIONARY STEADY

Of extremely rigid design and having a maximum capacity of $3\frac{1}{2}$ " (89mm) bar diameter, this attachment is rapidly clamped on to the bed by a plate and bolt and easily removed when not required.

The top section is locked by a knurled screw and the adjustable fingers are fitted with replaceable sintered bronze press-fit inserts.

REAR TOOLPOST

As an aid to production, a rear toolpost is available for fitting direct to the cross slide which is drilled and tapped ready to receive it.

Two tool positions are provided so that the tool may be fitted in the conventional manner or in the inverted position.

Using this toolpost (with the tool fitted in the conventional manner) left-hand threads can be very easily cut.

Supplied complete with all the necessary fixing screws, the only fitting required is the physical bolting of the base pad to the cross slide. Tee slots are provided in the base pad so that the toolpost may be adjusted in position on the base. Maximum tool depth that can be accommodated in either position is $\frac{5}{8}$ in. (16 mm).

The standard Allen keys and spanners supplied with the machine will fit all the nuts and screws in this assembly.

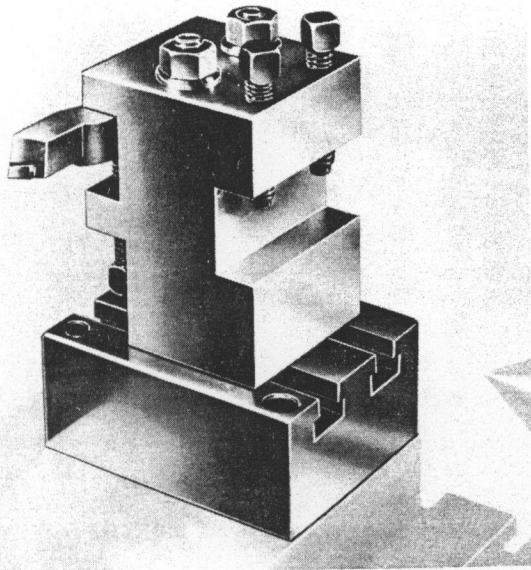
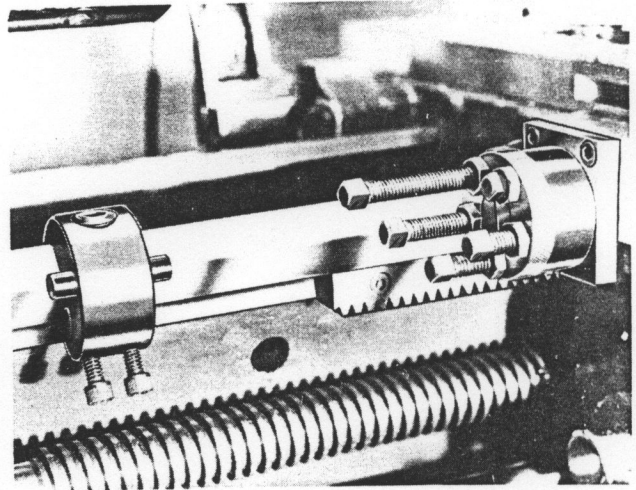

FEED STOPS

To provide an accurate and reliable means of repeating shoulder lengths, single type or five-position type feed stops are available. A five-position stop can also be supplied for repeating diameters.

With these units, the saddle or cross slide can be stopped in any desired position, the feed mechanism in the apron disengaging immediately contact is made.

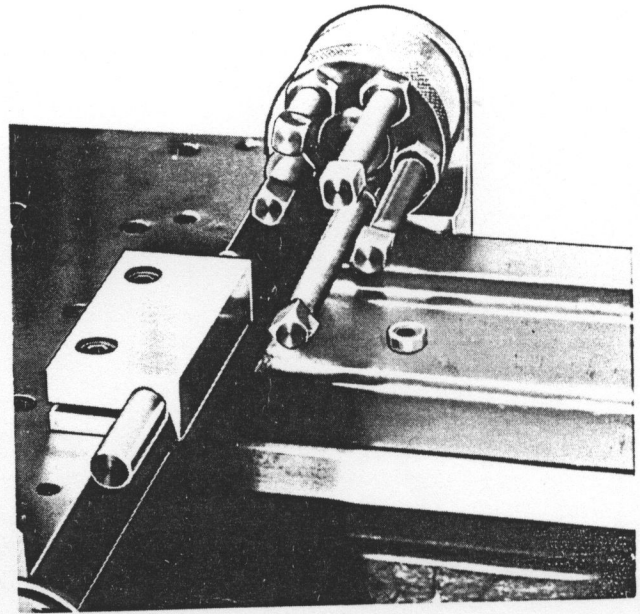

TELESCOPIC TAPER ATTACHMENT

This attachment can be used for producing tapers up to 10° in either direction.

It can be mounted directly on to the rear of the saddle without any modification other than the fitting of a new saddle screw and nut which is supplied with the unit.

The swivel slide is graduated in both radial degrees and ratios of taper on diameter (1 in 3 to 1 in 50). Great sensitivity of control is obtained when setting a taper by the use of the micro adjustment screw.

The cross slide handwheel is always used to control the tool and the base slide can be adjusted along the bed so that the taper may be cut in any position.

The attachment will deal with a length of 10 in. (254 mm) of taper at any one setting.

After attaching to the machine, all that is required to prepare the taper turner for use is the clamping of the connecting rod in the anchor bracket by means of the knurled thumb screw.

The fitting of this attachment in no way detracts from the use of the machine as a normal centre lathe. Change-over can be simply accomplished by loosening the connecting rod clamping screw and traversing the saddle towards the headstock to disengage the connecting rod from the clamp. Then remove the anchor bracket from the bed so that there is no obstruction to foul the connecting rod. By replacing the bracket and engaging the connecting rod, the taper turner is rapidly reset for use. Great care should be taken when re-adjusting or altering the fit of the base slide in the taper turner bracket, as any slackness will result in incorrect tapers.

To fit the taper attachment

1. The saddle and cross slide are ready drilled to receive the attachment, the necessary holes being drilled and tapped during manufacture.
2. Clean down the rear end of the saddle to receive the taper turner bracket.
3. Release the locknut in the centre of the cross slide handwheel.
4. Slide the cross slide to the rear of the saddle.
5. Remove the saddle screw nut fixing bolt and withdraw the screw and nut from the rear end.
6. Insert the taper turner saddle screw and nut and secure the nut with the fixing bolt.
7. Pull the cross slide forward and engage the saddle screw in the handwheel pinion. (NOTE: The locknut from the original saddle screw is not replaced, but should be retained in case it is needed when refitting the original screw.)
8. The slide block assembly can now be fitted to the thrust block on the rear of the saddle screw assembly. Engage the slides in the bracket and the slide block assembly on the slides. This will enable the bracket to be bolted to the rear of the saddle using the pre-tapped holes provided.
9. Finally, bolt the cross slide extension piece to the rear of the cross slide. Fit the connecting rod to the taper turner slide and the connecting rod clamp to the machined face on the back of the bed.

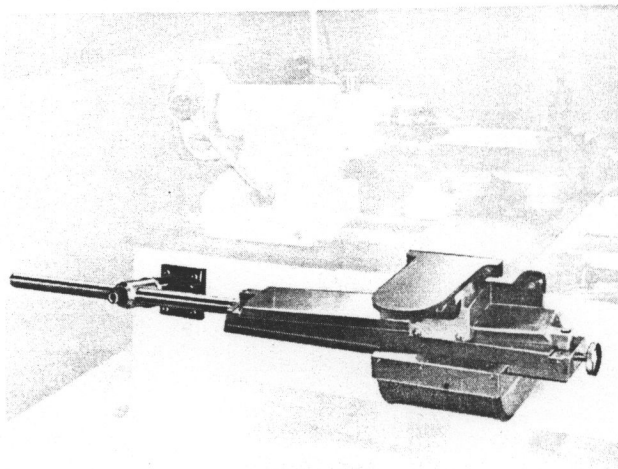

THE COLCHESTER CAPSTAN UNIT

The five-station, manually operated, inclined head capstan attachment is built on a base plate which utilises the existing tailstock ways of the bed and requires no fitting prior to use.

Having a maximum working stroke of $4\frac{1}{2}$ in. (114 mm), the length of travel can be adjusted for each station by setting the stop screws and the turret slide may be locked in any position by a lever situated at the rear of the attachment. Standard single spindle auto tool-holders with $\frac{3}{4}$ in. shanks (or 20 mm shanks if the attachment is supplied with metric bores) are accommodated in the turret which is positioned and locked

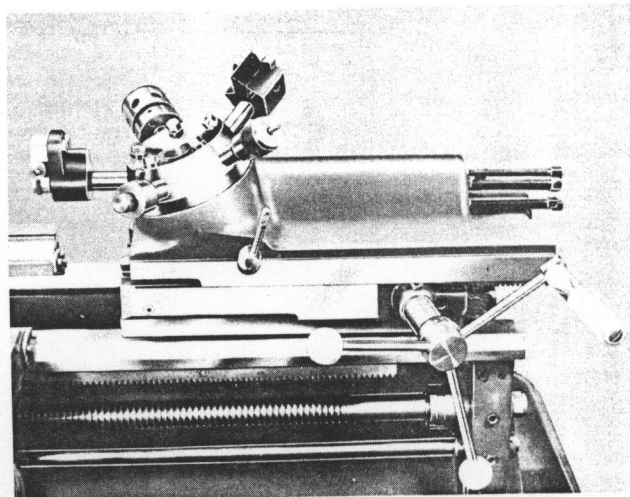

after each indexing to an accuracy of 0.0002 in. (0.005 mm) three inches (76 mm) from the turret face. Whilst indexing is normally achieved by returning the slide fully to the right by the handwheel, the turret can be rotated by hand if required.

NOTE: Tooling should be obtained through your usual supplier.

LOW VOLT LIGHTING UNIT

This extremely robust attachment consists of two units:

The light standard, which has a local switch built into the top of the shade, is attached to the back of the headstock by the bracket provided.

The transformer and main switch unit is fitted to the rear of the cabinet pedestal below the headstock.

All electrical connections are made as shown in the wiring diagram.

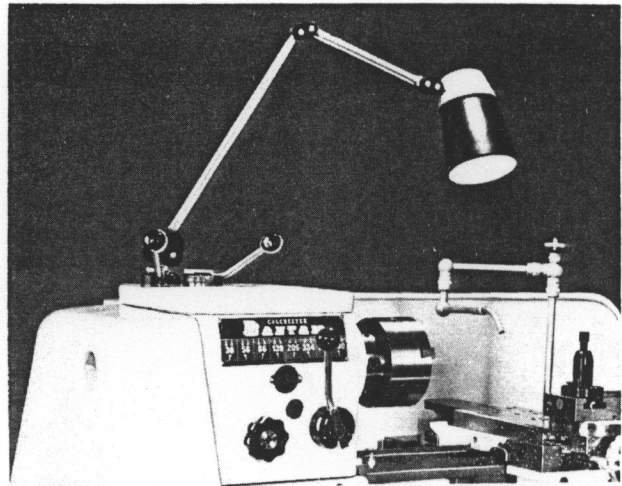

SERVICING AND MAINTENANCE NOTES

SPINDLE BEARING ADJUSTMENT

The adjustment of the spindle bearing assembly is carefully set before despatch of each lathe from the Works and should, thus, ensure a high standard of performance without the need for further attention.

The user is advised not to disturb this setting during normal use of the machine but to consult our Service Department. In those instances, however, where re-adjustment becomes necessary it is essential that the following procedure is strictly complied with:—

1. Set up a dial test indicator, having 'tenth' divisions (0.0001 in.) with the stylus registered on the nose-end of the headstock spindle. Preferably, locate the stylus centrally on a flat-nosed centre placed in the spindle bore. When the test indicator is set up on the saddle and slides it is advisable to lock the saddle by means of the locking screw before proceeding with the adjustment.
2. Take off the cover from the rear of the headstock and remove the cover plate over the spindle back bearing and screwed collar.
3. The spindle should then be rotated by hand from the back of the headstock whilst pulling and pushing at the nose end so that any end-float present can be read off the test indicator dial.

4. The correct setting of the bearings, with the headstock cold, is when the end-float condition does not exceed one ten-thousandth of an inch (0.0001 in. or 0.0025 mm) whilst THE SPINDLE REMAINS FREE TO BE TURNED BY HAND.

5. When adjustment is necessary to restore the limited end-float condition, release the locking screw of the screwed adjusting collar and push the spindle forward whilst rotating it in the hand to ensure that the bearing rollers are registering correctly in the bearing inner ring thrust faces.

6. Whilst keeping watch on the indicator dial, tighten the bearing adjusting collar until the excessive end-float is taken up. Now ascertain the end-float by pushing and pulling upon the spindle and make any necessary slight adjustment required to provide the correct setting (maximum 0.0001 in.).

7. Tighten the locking screw of the adjusting collar and, once more, re-check the end-float to be sure that no inadvertent alteration of the setting has taken place.

8. Refit the back bearing cover and replace the end guard.