



CLAUSING DIVISION, ATLAS PRESS COMPANY, KALAMAZOO, MICH., U.S.A.

Manufactured by
THE COLCHESTER LATHE CO. LTD. COLCHESTER, ESSEX, ENGLAND

THIS MANUAL

applies to the Clausing-Colchester 15 in × 30 in and 15 in × 48 in heavy duty, geared-head precision lathes.

A full understanding of the contents will help you obtain the best results from the machine and achieve the standards of accuracy available.

Our Technical Service Department is always at your disposal to discuss any problems concerning the application of Clausing-Colchester lathes and their planned accessories or attachments. The aim is to ensure maximum satisfaction with your lathe.

The machine serial number is stamped at the tailstock end of the bed and **MUST** be quoted in all communications regarding your lathe.

Due to the Company policy of continuous improvement, designs may be modified or changed at any time without notice and this manual applies only to the machine with which it is issued.

THE SERIAL NUMBER OF YOUR MACHINE IS *F.4-606H1*

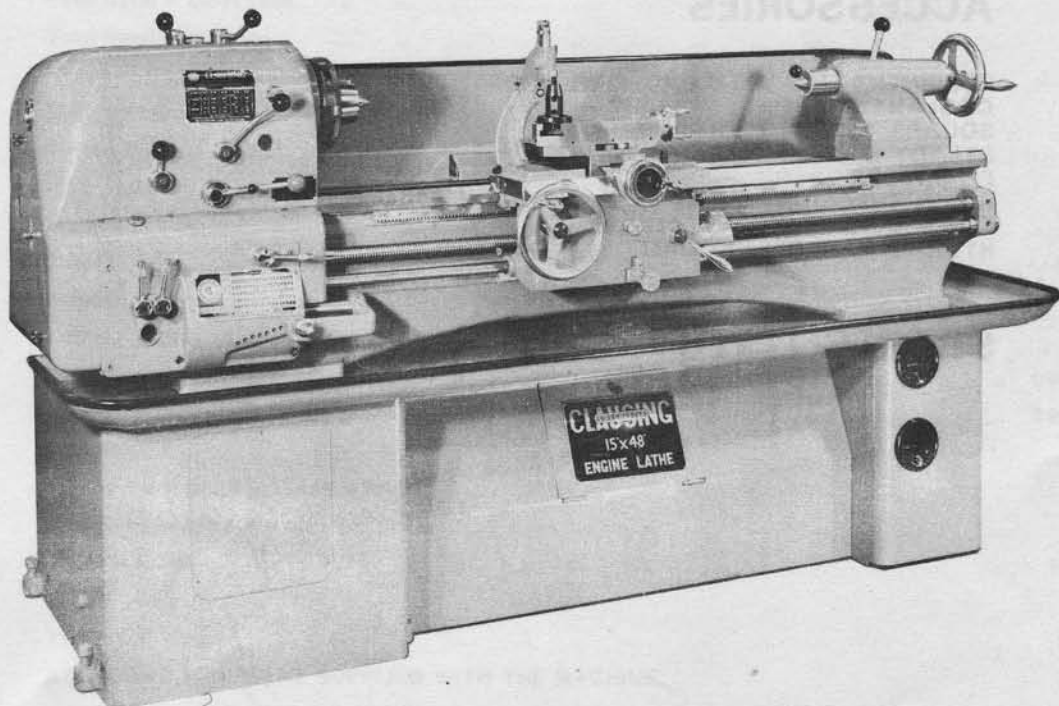

INDEX

SPECIFICATION 3

INSTALLATION

INSTALLING	6
LIFTING	5
CLEANING AND BOLTING DOWN	5
ELECTRICAL WIRING	8
CHUCK MOUNTING	6
LUBRICATION	10

OPERATION

DRIVE STARTING STOPPING REVERSE	12
HEADSTOCK SPEED SELECTION	12
SWING FRAME	13
GEARBOX	13
APRON AND THREAD CUTTING	14 15
SETTING UP GEAR TRAIN	14
METRIC THREAD CUTTING	15
SADDLE AND SLIDES	16
THE BED AND TAILSTOCK	16

ACCESSORIES

EQUIPMENT LIST WITH ORDERING CODES	17
COOLANT SYSTEM	17
SQUARE TURRET TOOLPOST	20
STEADY REST AND REAR TOOLPOST	20
FEEDSTOPS	20
RAPID THREADING UNIT	17
TELESCOPIC TAPER ATTACHMENT	21
HYDRAULIC PROFILING UNIT	22

SPARES LISTS

BRIEF SPECIFICATION

This specification applies to all four standard models of the Clausing-Colchester 15 in Swing lathes as follows:

6534 . 15 in × 30 in	Straight bed lathes
6535 . 15 in × 48 in	Straight bed lathes
6536 . 15 in × 30 in	Gap bed lathes
6537 . 15 in × 48 in	Gap bed lathes

CAPACITIES

Height of centres	7½ in
Swing		
Over bed...	15 in
Over cross slide	8¾ in
Distance between centres	30 in or 48 in
Diameter of faceplate	14 in
Gap-bed Models		
Turning diameter in gap	24 in
Width in front of faceplate	6 in
Capacity of travelling steady rest	2½ in
Overall length	74 in or 92 in
Overall width	38 in
Weight (approx)	2,184 lb or 2,296 lb

HEADSTOCK

Spindle bore (Max. bar diameter)	2 in
Spindle nose	A.S.A long taper L.1
Taper in spindle nose bush	No. 4 Morse
Spindle speeds (two-speed motor)	16
Range of spindle speeds (two-speed motor)	37—1500 r.p.m.

CARRIAGE

Total travel of cross slide	9 in
Total travel of top slide	4¾ in
Height from top of top slide to centre line of spindle	1⅝ in
Max. tool shank size (pillar type tool post)	⅝ × 1 in

THREADS AND FEEDS

Pitch of leadscrew	4 t.p.i.
Number of threads	45
Range	4—120 t.p.i.
Number of feeds	45
Range per rev. of spindle		
Longitudinal	0.0017—0.048 in
Cross	0.0008—0.024 in

TAILSTOCK

Spindle travel (No. 4 M.T. centre fitted)	6¾ in
Spindle travel (Standard tang drill fitted)	5¼ in
Taper in spindle	No. 4 Morse

DRIVE

Two-speed motor	2½—5 h.p.
-----------------	--------	-----------

STANDARD EQUIPMENT SUPPLIED WITH THE MACHINE

Full length splash guard	One 14" dia. faceplate
Two No. 4 Morse taper centres	One 8" dia. slotted driving plate
One centre bush	Travelling steady rest
Wrenchs etc.	

For details of additional equipment available, see Section ACCESSORIES

FOUNDATION PLAN

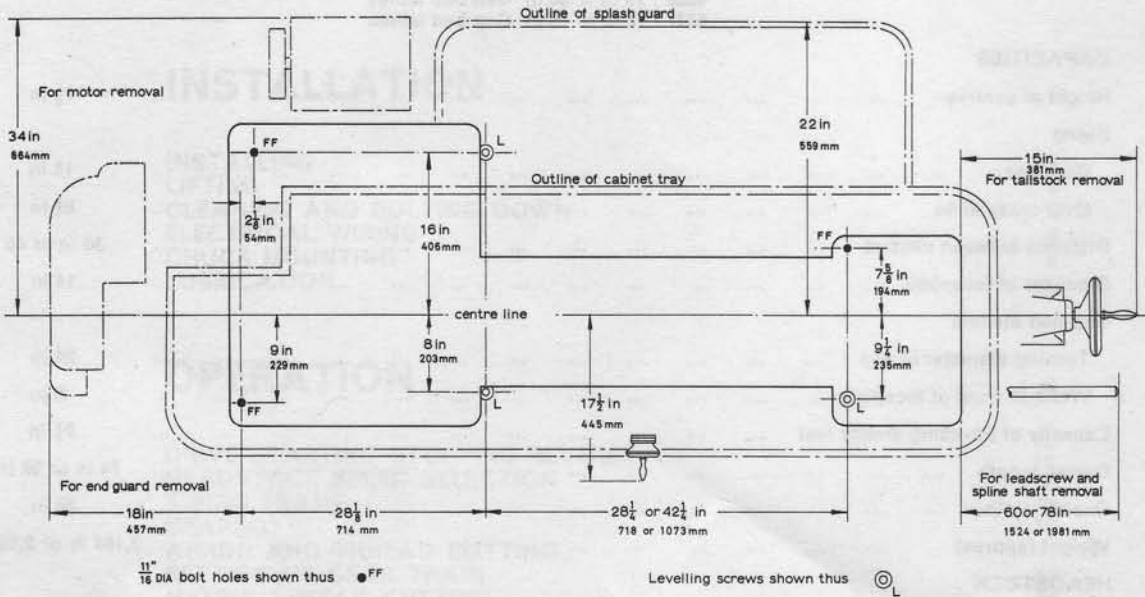

ACCESSORIES

SPARES LISTS

INSTALLATION

INTRODUCTION

Clausing-Colchester lathes are the result of half a century of concentration in manufacture of this type of machine tool. Whilst essentially precision tools intended for producing accurate workpieces, the design of robust construction and simplified controls makes these machines suitable for tooling in production work.

All castings are naturally aged for at least six months to avoid possible distortion. Jigs and special-purpose machines are used extensively in our manufacturing operations to ensure interchangeability of components. Care is taken in all processes of all departments to ensure your satisfaction with the machine.

The headstock is an all-g geared arrangement, totally enclosed within an oilbath and giving sixteen spindle speeds. The main spindle is precision finished from a heat-treated high tensile steel forging and is carried at the front end on Gamet high precision double row taper roller bearings of exceptional accuracy which are specially manufactured to our requirements. The rear end of the spindle is carried in a single-row taper roller bearing of similar design. All headstock spindles and shafts are carried in needle roller anti-friction bearings.

WORKING AREA

When deciding upon the position for the lathe, remember that sufficient room must be allowed not only for ease of operation but to permit the end guard to be opened, for access to the motor compartment at the rear of the cabinet base and for the servicing operations recommended.

A foundation plan is included which gives the main installation dimensions and also the recommended minimum space required for efficient operation of the machine under all conditions of working.

CLEANING

Each lathe is delivered having all bright machined surfaces covered with a heavy protective coating. Before attempting to operate the machine remove all traces of the preservative using white spirit or kerosene.

DO NOT USE CELLULOSE SOLVENTS FOR CLEANING—THESE WILL DAMAGE THE PAINT FINISH.

When cleaning, pay particular attention to the slides and spindle nose. It is essential that the end guard be removed and the gear train carefully cleaned before operating the lathe.

All cleaned parts should then be dried using fluff-free cloth and the bright surfaces given a light coating of

LIFTING

The complete machine weighs approximately 2,300 lb and proper equipment must, therefore, be made available for handling this weight. All lifting and repositioning should be carried out with great care. It is recommended that a lifting bolt with clamp plates to the dimensions shown on the sketch should be used. Wind the saddle and slides towards the tail end of the lathe and fit the clamp plate securely at the point of balance of the machine.

Do not sling the machine from any other points. In case of difficulty, consult your local Clausing-Colchester agent.

INSTALLING

In order to achieve the full standards of accuracy built in to your Clausing-Colchester lathe, it is essential that the machine be installed upon a solid concrete base which must be as level and free from vibration as possible. For most applications the machine will then perform perfectly satisfactorily whilst free-standing. Six mounting points are built into the cabinet base, and these will give all the support needed by the machine. If there are objections to having a free standing machine, bolts may be used, providing they are not overtightened. When operating at high speed on out-of-balance work, it may become necessary to bolt the machine to the concrete foundation.

Careful attention to siting and foundation will greatly add to the accuracy of the work produced and to the life of the machine. If the lathe must be installed above ground floor level, it is essential for best results to provide a concrete floor and to position the machine headstock as close as possible to a supporting wall or pillar. Wooden floors are not recommended because changes in atmospheric conditions which affect the floor will adversely affect the alignment of the machine. When wooden floors siting is unavoidable, a section of the floor should be taken up and a concrete base built up to the floor level.

It is not recommended that the machine is placed on felt or rubber mats no matter what type of foundation is provided.

THE MACHINE SHOULD NOT BE GROUTED IN.

FREE STANDING MACHINES

1. Position the lathe level upon the three fixed feet (shown in the installation plan).
2. Screw down the adjustable feet to each take its share of the load without losing ground contact at any other foot. Lock the adjustable feet.
3. Run the lathe. Any evident vibration will be due to incorrect setting of the adjustable feet; and this can be eliminated by slight alteration of the setting whilst the machine is running. Re-lock the adjustable feet.
4. For all normal operating requirements, the mounting as described will give all the support necessary.
5. It is essential that the machine is correctly levelled before using it in production and each time an adjustment is made to the foundation bolts or mounting feet. A precision engineers' level should be used and readings taken across headstock and tailstock ends and then in two positions on both front and rear bed shears in a longitudinal direction. Careful attention to levelling will greatly add to the accuracy of work produced and to efficient life of the machine. If the foundation is not accurate and level it may be necessary to adjust the levelling screws provided at the base of the cabinet.

BOLTING DOWN

1. Position the lathe level upon the three fixed feet (shown in the installation plan as FF).
2. Screw down the adjustable feet to each to take its share of the load without losing ground contact with any other foot. Lock the adjustable feet.
3. Insert $\frac{1}{2}$ in diameter foundation bolts through the bolt positions provided and into cleanly drilled holes in the concrete foundation. When inserted, they should be firmly secured within the foundation before attempting to tighten the holding-down nuts.
4. Secure the holding-down nuts firmly but avoid overtightening. Bolt tension should be just sufficient to retain the machine in position without disturbing the cross-wind alignment.
5. Run the machine. Any evident vibration will be due to incorrect setting of the adjustable feet which can be remedied by slackening all mounting bolts and altering the adjustment a little at a time. Care and attention given to obtain the correct setting at this stage will be well repaid. Re-lock the adjustable feet before tightening the mounting bolts.
6. It is essential that the machine is correctly levelled before using it in production and each time an adjustment is made to the foundation bolts or mounting feet. A precision engineers' level should be used and readings taken across headstock and tailstock ends and then in two positions on both front and rear bed shears in a longitudinal direction. Careful attention to levelling will greatly add to the accuracy of work produced and to efficient life of the machine. If the foundation is not accurate and level it may be necessary to adjust the levelling screws provided at the base of the cabinet.

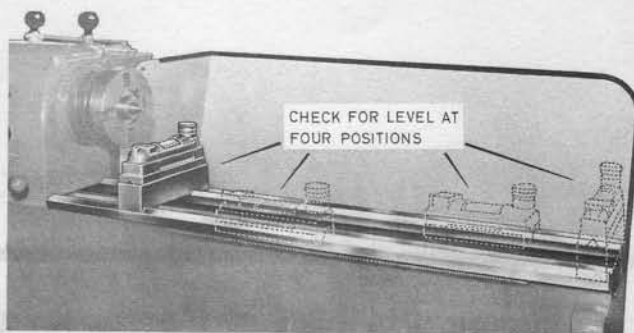

CHUCK MOUNTING

The A.S.A. long-taper key drive spindle nose (to L1 standard) is incorporated on this machine and has been selected in order to overcome the danger of chuck or faceplate detachment when the spindle is stopped or reversed rapidly.

Before fitting a chuck to the spindle nose, ensure that the centre and centre bush have been removed. Care should be taken to make sure that the taper and the key of the spindle nose, together with the internal tapered bore of the chuck, are scrupulously clean. Any dirt, swarf or burrs on these surfaces will upset the accuracy of the machine, may prevent the correct locking of the chuck on the spindle nose and can cause irremediable damage to the mating surfaces. The spindle nose drawnut engages with the thread on the back of the chuck; and when the drawnut has been screwed up by hand, without trouble, the special spanner wrench supplied with the machine should be used to tighten the drawnut fully. It is advisable to give the stock of the Spanner wrench one or two sharp blows with a mallet to ensure that the drawnut is quite tight. Do not, however, fit extension handles over the spanner wrench for tightening purposes.

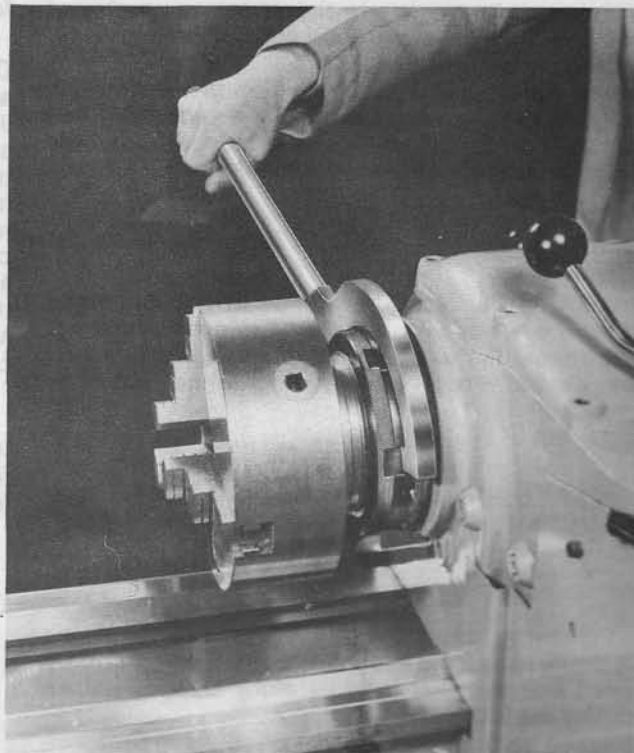

NOTE:

Should the chuck remain fitted for any length of time, the locking procedure should be repeated frequently. This is important when the machine is engaged on work which involves intermittent or heavy cutting. If the chuck is fitted with the spindle nose still warm from operating, it is essential that the drawnut is re-tightened before starting the machine again from a cold condition.

Releasing the drawnut will free the chuck or faceplate from the taper. Care must be taken whenever this is done, however, to ensure that the chuck does not slide off the spindle nose to damage the bed or saddle. It is advisable to obtain assistance each time the chuck is to be removed.

To avoid the possibility of moving the machine from its levelled position, final locking of the chuck or faceplate should be made with the spanner wrench horizontal.

ALIGNMENT CHECKS

When the machine is installed initially, or after subsequent re-positioning, it is advisable to carefully check the alignment of the headstock and tailstock. All machines are accurately aligned before despatch from the Works, but transit shocks may render a further checking necessary or of benefit.

HEADSTOCK ALIGNMENT

Grip a length of mild steel bar in the chuck and using keen tools take a light cut over the outside diameter for about 6 in of its length. Do not use the tailstock centre as a steady during this test.

Micrometer readings at the two ends of the turned diameter (at A and B in the sketch) should be precisely the same. If the readings differ, the headstock should be re-aligned as follows:—

1. Slacken the six socket-head headstock retaining screws until only finger tight. This will allow the headstock to pivot about the locating dowel.

2. Accurate adjustment for re-alignment can be made using the 'set-over' pad which is built into the underside of the headstock and rests between the bedway.
3. After alignment, tighten the locknut on each adjusting screw of the set-over pad and securely tighten headstock retaining screws.

TAILSTOCK ALIGNMENT

Place a prepared 12 in ground steel bar between centres, as shown in the sketch. Then to the top slide fix a dial indicator with its anvil running along the horizontal centre-line of the test bar. By traversing the saddle along the bed, an accurate check on alignment can be made.

Any alignment errors may be rectified by adjustment to the two set-over screws provided one at each side of the tailstock base.

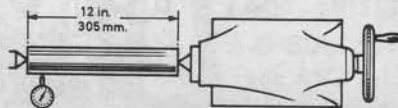
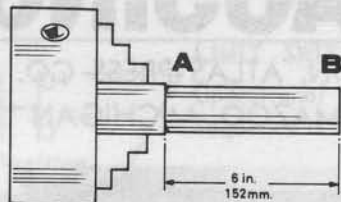

INSTRUCTIONS and PARTS

CLAUSING COLCHESTER

DIVISION, ATLAS PRESS CO.
KALAMAZOO, MICHIGAN

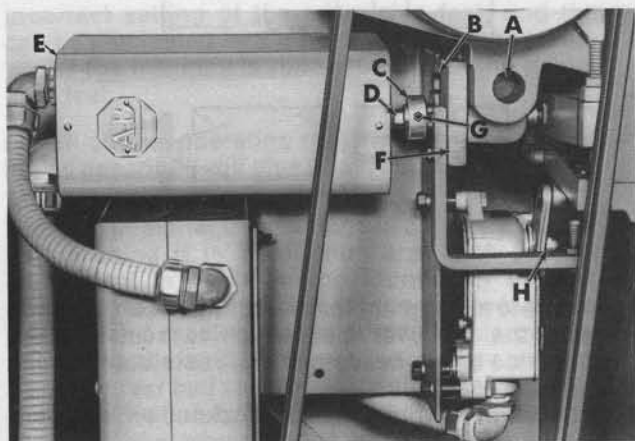

Figure 1

1. Before installing switch panel assembly turn the reversing switch shaft (D, fig. 1) clockwise as far as it will go, and then back two "clicks" — the switch is now in the off position.

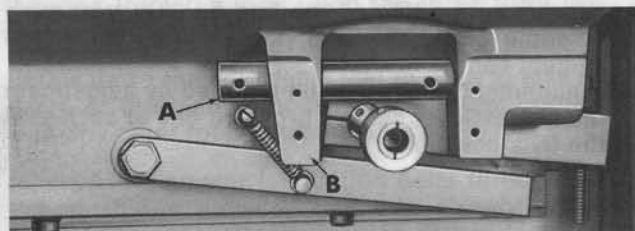

Figure 2

2. Slide switch panel mounting bar (A, fig. 2) in holes in back of headstock (B).
3. Slide drum switch shaft (D, fig. 1) with switch panel into coupling (C), then align mounting bar (A) with holes in mounting plate (F) and secure in place with two 5/16-18 x 1-3/4 hex cap screws (B). DO NOT TIGHTEN SECURELY.

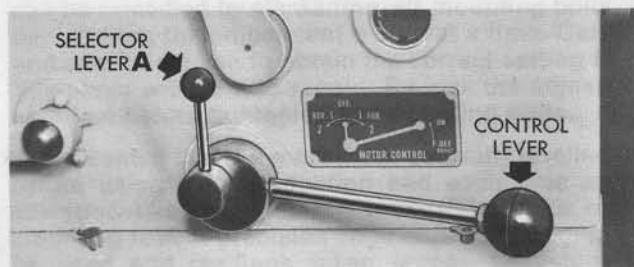

Figure 3

4. Make sure selector lever (A, fig. 3) rotates freely. If binding condition occurs, loosen mounting screws (B, fig. 1) and realign, then tighten screws securely.

INSTALLING ELECTRIC CONTROL PANEL ASSEMBLY

ON

15" CLAUSING-COLCHESTER LATHES

FROM SERIAL NO. TO

April 1964

FILE NO. 15-CC ELEC-4

5. Hold the small reversing selector lever at the front of the lathe head stock in a vertical position and securely tighten set screw (G) in coupling collar (C) to clamp reversing switch shaft.

IMPORTANT: Be sure set screw (G) is at 90° to slots in coupling.

6. Connect the six numbered wires in the conduit from the reversing switch to the corresponding numbered motor leads. Use small screws and nuts, and tape connections.

7. Bring the main electric line into the magnetic starter through a knock out opening in the top of the box and connect the wires to the correct terminals as shown in the wiring diagram inside the switch cover.

8. Make sure red control lever is in "down" or "off" position.

9. Select the speed and direction of spindle rotation desired with the spindle selector lever.

10. Move the red control lever up to start the lathe and motor. To stop the lathe, push the lever down—continue to push the control lever down to operate the brake and quickly stop the spindle.

11. Before changing motor speed or direction of rotation, the control lever must be returned to the "off" position.

NOTE: The limit switch incorporates a safety feature to protect the machine and operator. In the event of an electrical power failure, the lathe cannot be accidentally restarted and will not restart by itself. It is necessary for the operator to return the control lever to the "off" position, and then move the lever to the "on" position to start the lathe.

12. If spindle rotation does not correspond to selector switch notation, interchange any two line leads. If the motor does not start when the control lever is in the "up" or "on" position, or stop in the "down" position, adjust the travel of the limit switch arm on the switch lever by loosening the adjusting nut (H, fig. 1). If the brake lever at the rear of the headstock jams on the threaded end of the brake link, adjust set screw in the bracket on the switch panel to limit travel of the switch lever.

WIRING TO POWER SUPPLY

APPLIES TO CLAUSING-COLCHESTER 15" LATHES FROM SERIAL NO. _____ TO _____

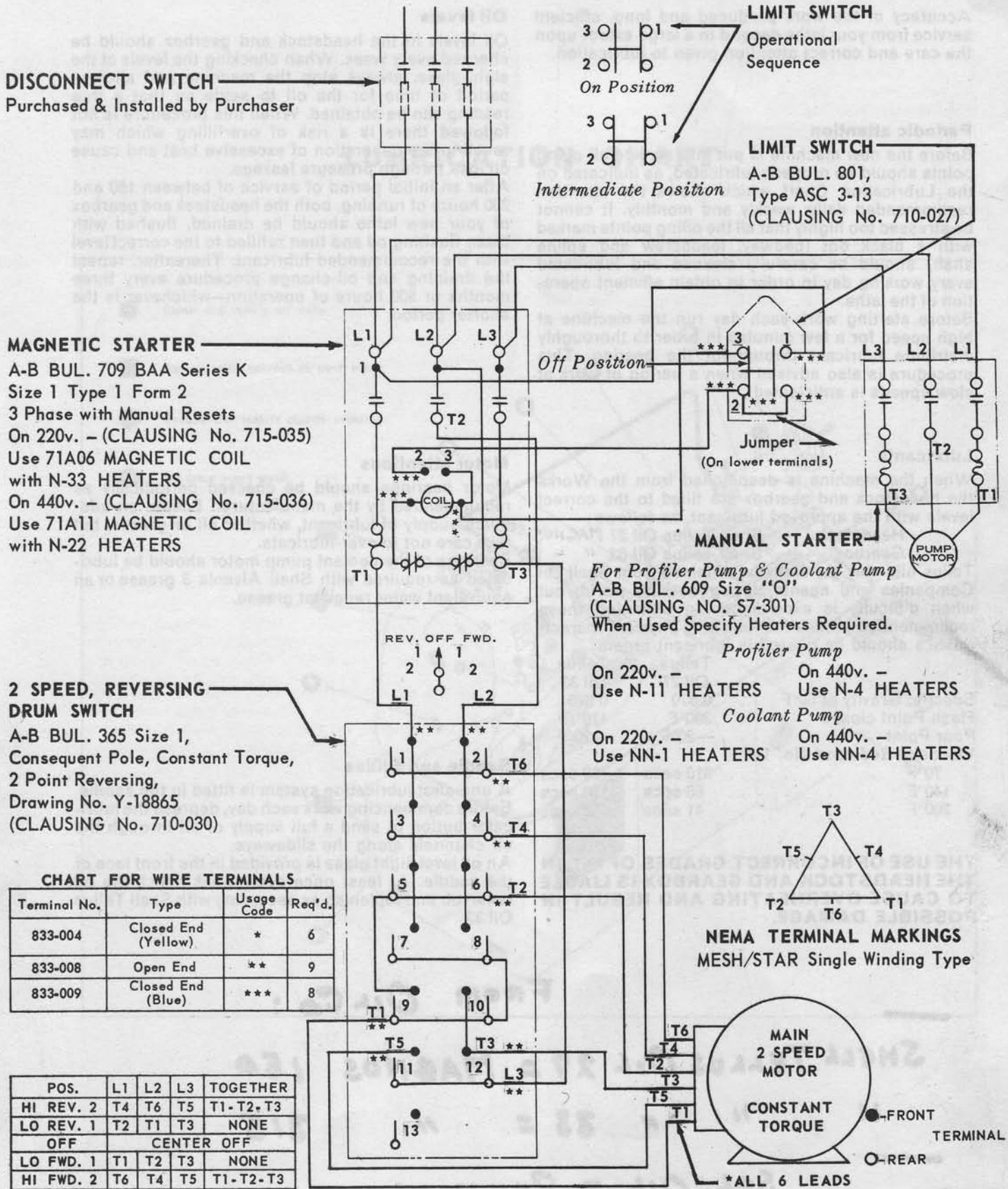

CHART FOR WIRE TERMINALS

Terminal No.	Type	Usage Code	Req'd.
833-004	Closed End (Yellow)	*	6
833-008	Open End	**	9
833-009	Closed End (Blue)	***	8

POS.	L1	L2	L3	TOGETHER
HI REV. 2	T4	T6	T5	T1-T2-T3
LO REV. 1	T2	T1	T3	NONE
OFF	CENTER OFF			
LO FWD. 1	T1	T2	T3	NONE
HI FWD. 2	T6	T4	T5	T1-T2-T3

LUBRICATION

Accuracy of the work produced and long, efficient service from your lathe depend to a large extent upon the care and correct attention given to lubrication.

Periodic attention

Before the new machine is put into service all oiling points should be properly lubricated, as indicated on the Lubrication Chart which shows the attention recommended daily, weekly and monthly. It cannot be stressed too highly that all the oiling points marked with a black dot (bedway, leadscrew and spline shaft) should be carefully cleaned and lubricated every working day in order to obtain efficient operation of the lathe.

Before starting work each day run the machine at high speed for a few minutes in order to thoroughly distribute lubricant throughout the gearing. This procedure is also advised when a period of work at slow speeds is anticipated.

Lubricants

When the machine is despatched from the Works the headstock and gearbox are filled to the correct levels with the approved lubricant, as follows:—

Headstock — Shell Tellus Oil 27 **MAGNUS 150**
 Gearbox — Shell Tellus Oil 33 // - 315

Tellus oils may generally be obtained from Shell Oil Companies and agents throughout the world, but when difficulty is experienced in obtaining these recommended grades the following physical characteristics should be quoted in lubricant orders;

	Tellus Oil 27	Tellus Oil 33
Specific Gravity at 60°F	0.870	0.876
Flash Point closed	390°F	410°F
Pour Point	-20°F	-20°F
Viscosity Redwood No. 1—		
70°F	310 secs	750 secs
140°F	68 secs	112 secs
200°F	41 secs	52 secs

THE USE OF INCORRECT GRADES OF OIL IN THE HEADSTOCK AND GEARBOX IS LIABLE TO CAUSE OVERHEATING AND RESULT IN POSSIBLE DAMAGE.

Oil levels

Oil levels in the headstock and gearbox should be checked every week. When checking the levels at the sight-glass, always stop the machine and allow a period of time for the oil to settle so that a true reading can be obtained. When this procedure is not followed there is a risk of overfilling which may result in the generation of excessive heat and cause oil loss through pressure leakage.

After an initial period of service of between 150 and 200 hours of running, both the headstock and gearbox of your new lathe should be drained, flushed with clean flushing oil and then refilled to the correct level with the recommended lubricant. Thereafter, repeat the draining and oil-change procedure every three months or 500 hours of operation—whichever is the shorter period.

Motor attentions

Motor bearings should be checked periodically as recommended by the manufacturer. Ensure an adequate supply of lubricant, whether oil or grease, but take care not to over-lubricate.

Bearings of the coolant pump motor should be lubricated as required with Shell Alvania 3 grease or an equivalent water repellent grease.

Saddle and Slides

A one-shot lubrication system is fitted in the saddle. Before commencing work each day, depress the lubricator button to send a full supply of oil through the oil channels along the slideways.

An oil level sight glass is provided in the front face of the saddle. At least once every week check the oil reservoir and replenish as necessary with Shell Tellus Oil 33.

FROM OIL CO :

SHELL TELLUS OIL 27 = MAGNUS 150

" " " 33 = " 315

SOL. OIL = PHILKOOB

LUBRICATION CHART

- Clean and lightly oil daily.
- Top up with correct oil each week.
- ◆ Grease the Matrix clutch monthly.
- Oil once every week.

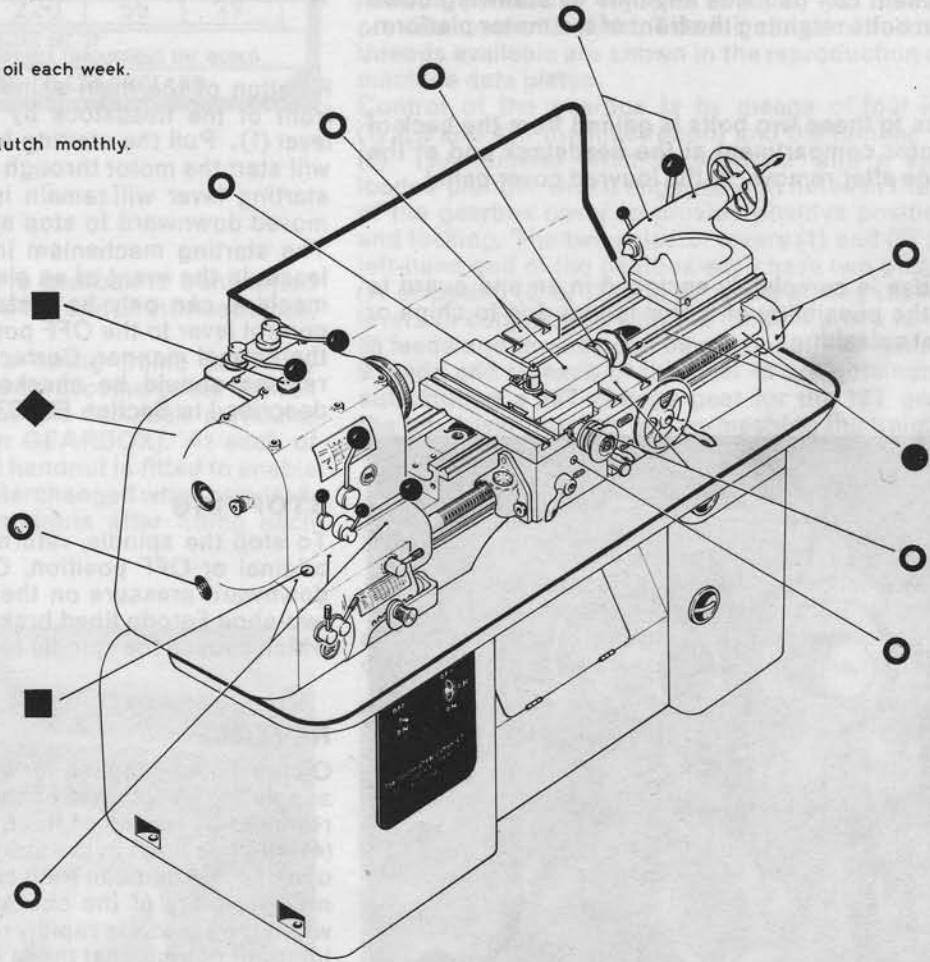

OPERATION

DRIVE

The headstock gear train is driven from a two speed electric motor through standard vee belts and pulley drives.

When correctly tensioned, belts can be deflected $\frac{3}{4}$ in. when pressed at a point midlength between the motor and headstock pulleys.

After an initial period of service (between 150 and 200 hours of operation) it may become necessary to re-adjust the tension of the driving belt to eliminate slap, vibration or slip due to belt stretching. Tension adjustment can be made any time by screwing down the two bolts retaining the front of the motor platform.

Access to these two bolts is gained from the back of the motor compartment at the headstock end of the machine after removal of the louvred cover panel.

The drive is completely enclosed in an end guard to avoid the possibility of motor failure due to chips or coolant splashing.

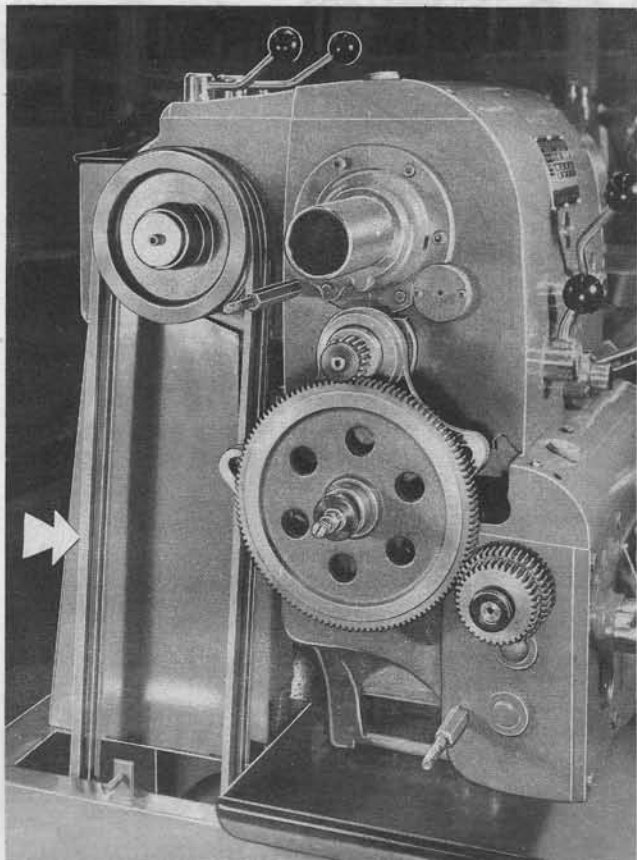

STARTING

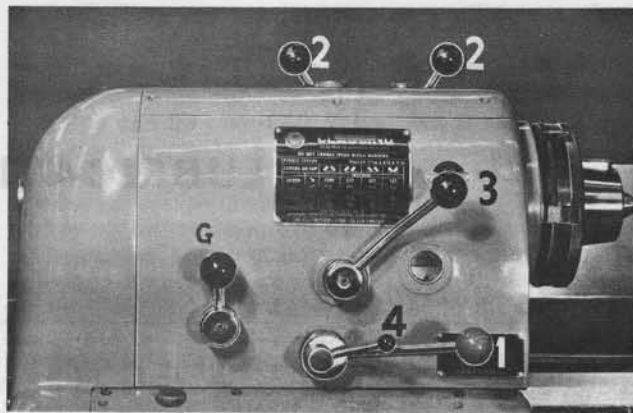

Rotation of the main spindle is controlled from the front of the headstock by means of the starting lever (1). Pull the starting lever upward. This action will start the motor through an air brake starter; the starting lever will remain in this position until it is moved downward to stop spindle rotation.

The starting mechanism incorporates a no-volt release. In the event of an electrical supply failure, the machine can only be restarted by first moving the control lever to the OFF position and then starting in the normal manner. Correct operation of the no-volt release should be checked from time to time, as described in Section ELECTRICAL WIRING.

STOPPING

To stop the spindle, return the starting lever to the original or OFF position. On direct start machines, downward pressure on the starting lever operates a two-shoe Ferodo lined brake inside the driving pulley which causes the spindle to stop instantly.

REVERSE

On machines supplied for operation on 3-phase A.C. supply (only) rotation of the main spindle is readily reversed by means of the finger-tip reversing switch (4) which is inset in the starting lever. Because of the use of the American long taper spindle nose there is no possibility of the chuck or faceplate running off when the spindle is rapidly reversed or stopped; providing, of course, that these have been correctly fitted.

HEADSTOCK SPEED SELECTION

Speed selection is by means of two levers on the top of the headstock (2) and one lever on the front (3). Each lever has two positions, providing eight spindle speeds as shown on the data plate; but this range is increased to sixteen speeds by the use of a two-speed motor. The two-speed control switch for the motor is incorporated into the headstock controls (4). Lever positions and a chart of the speeds are shown in the







The small lever (G) is used in conjunction with gear-box controls for reversing the direction of feed. **THE SPINDLE AND HEADSTOCK GEARING MUST ALWAYS BE STOPPED BEFORE MOVING ANY OF THE CHANGE LEVERS.**



COLCHESTER

ATLAS PRESS CO. KALAMAZOO, MICH. U.S.A.

DO NOT CHANGE SPEED WHILE RUNNING

SPINDLE SPEEDS		PULLEY 2300 & 1150			
LEVERS ON TOP					
HIGH SPEED					
LEVER		1500	1050	260	180
AT		630	440	110	75
LOW SPEED					
FRONT		750	525	130	90
		315	220	55	37

USE SHELL TELLUS OIL 27
OBTAINABLE FROM SHELL OIL COMPANIES THROUGHOUT THE WORLD

THE COLCHESTER LATHE CO. LTD. ENGLAND

SWING FRAME

The drive from headstock to gearbox is transmitted through the train of gears on the end of the headstock, enclosed by the end cover.

The gears are fitted to a swing frame assembly which is readily adjustable to accommodate the full range of change gears available for each particular machine (see also Section GEARBOX). At each of the gear spindles a knurled handnut is fitted to enable gear wheels to be rapidly interchanged when required. Be sure to tighten the handnuts after fitting each gear wheel.

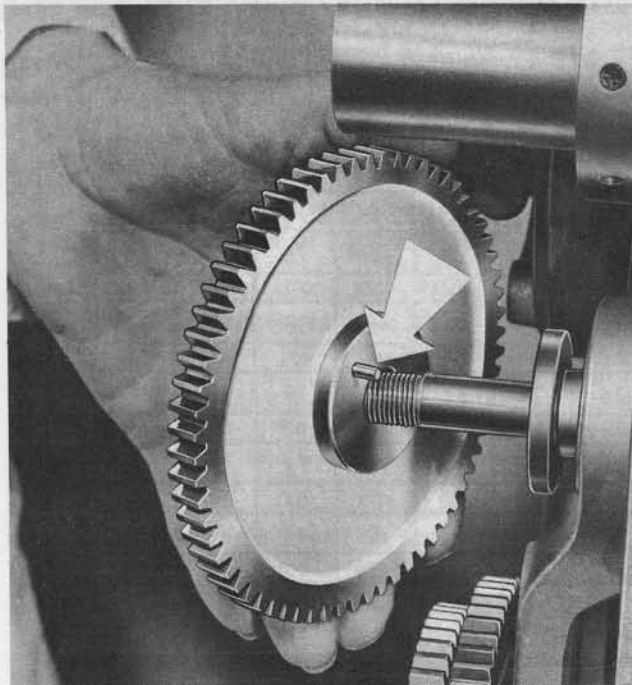

A shear pin safety device is fitted as a measure to protect against overload when screwcutting. A broken shear pin can be replaced easily by removing the top gear in the train, then the splined sleeve which carries the gear. The broken portion of pin may then be tapped out of the sleeve, from the side opposite to the splines. To remove the other broken portion, the shaft should be rotated until the pin hole is opposite the slot in the housing and swing frame then the broken pin may be knocked straight through and will drop out through the slot. A new pin can then be inserted and the top gear and sleeve re-assembled. In case of difficulty in obtaining new shear pins they can be manufactured from $\frac{1}{8}$ in. mild steel rod to British Standard EN1A (shear strength 20 tons per sq. in.)

No other material should be used.

GEARBOX

The standard gearbox covers a range of 45 feeds and threads (including $11\frac{1}{2}$ and 23 t.p.i.) but does not provide metric threads. The full range of feeds and threads available are shown in the reproduction of the machine data plates.

Control of the gearbox is by means of four levers (1, 2, 3 and 4 in the illustration) and the tumbler shaft (5). The tumbler shaft is provided with a spring-loaded plunger which engages with holes in the front of the gearbox cover to provide positive positioning and locking. The two selector levers (1) and (2) at the left-hand end of the gearbox each have two positions (A or B) and (C or D) and by manipulating these two levers in conjunction with the tumbler arm a range of 36 feeds and threads can be obtained. The remaining 9 feeds and threads of the total 45 are obtainable by substituting a 36T change gear for the 18T gear on the top driver position and re-meshing the train. This 36T change gear is supplied stowed alongside the 42T change gear on the gearbox driving shaft.

SPINDLE AND HEADSTOCK GEARING MUST BE STOPPED BEFORE ANY OF THE LEVERS CONTROLLING THE GEARBOX ARE MOVED.

A third lever (3) disengages the leadscrew when this is not actually required for screwcutting. A lever (4) situated high on the front of the headstock controls direction of the feeds, reversing them as required.

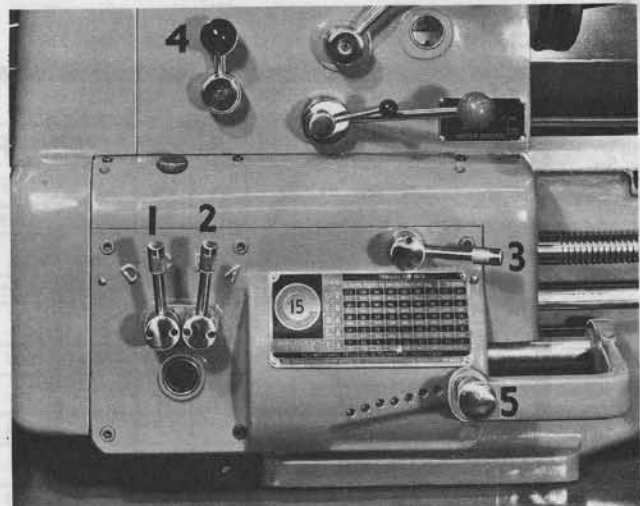

NOTE:—The leadscrew should never be allowed to revolve except when screwcutting; it should be cleaned and lightly oiled each time before use.

THREAD CUTTING

1. Threads available from the gearbox

The screwcutting dial on the apron has four numbered divisions and four sub-divisions marked on its surface, clearly visible from the operating position. The housing carrying this dial is located to the side of the apron and is retained in position by a knurled handscrew. When not required for use it may be swung out of contact with the leadscrew, since it is only employed when screwcutting is actually carried out.

To cut an even number of threads per inch (e.g. 12 t.p.i., 14 t.p.i.) the leadnut may be engaged at any division on the dial. For cutting an odd number of threads per inch (e.g. 13 t.p.i.) the leadnut must be engaged only on the numbered divisions. For fractional threads (e.g. $4\frac{3}{4}$ t.p.i.) the leadnut must only be engaged at the division marked 1 on the dial.

When engaging the leadnut, care should be taken to ensure that the appropriate dial division coincides exactly with the fixed point on each pass.

The settings of gear box levers for the threads available from the gearbox are shown on the machine data plates which are reproduced below

2. Threads not available from the gearbox

To cut special and multi-start threads which are not immediately available from the gearbox, it is necessary to use special change gears which are obtainable as extra equipment. For calculating the number of teeth in the required gears the following formula should be used:

$$\text{Thread to be cut} = \frac{3 \times X \times Y}{14 \times T} = \frac{\text{Driver gear}}{\text{Driven gear}}$$

Where X = hole in feed box

Y = 1 with selector levers on A C

2 with selector levers on A D

4 with selector levers on B C

8 with selector levers on B D

and T = Number of threads per inch to be cut

Values for X are as follows:—

0 0 0 0 0 0 0 0 0
28 26 24 23 22 20 19 18 16

Example

It is required to cut 27 t.p.i.

The values of X and Y may be chosen from any of the relevant numbers given above; and there is no rule about the choice. If the values selected give impossible numbers of teeth, try other values of X and Y and continue so doing until a practicable result is obtained.

Setting up gear train (27 t.p.i.)

1. Remove gear from headstock spindle.
2. Loosen swingframe (quadrant) locking nut located between swing frame and end of bed. Swing quadrant until 120T idler gear is out of mesh with gear on gearbox shaft (A).
3. Loosen idler gear stud nut located on inside of quadrant, slide 120T idler gear away from headstock spindle.
4. Select the proper gear for headstock spindle position (i.e. 32T as example). Place gear in position on spindle and secure in place.
5. Slide 120T idler gear up until properly meshed with gear on headstock spindle and secure in place. For correct mesh; place piece of heavy wrapping paper (.005 in. thick) between teeth of meshing gears, tighten gears in position and remove paper.
6. Check gear in position on gearbox spindle. For obtaining 27 t.p.i. it should be 42T gear (B).
7. Swing quadrant so 120T idler gear is in proper mesh with gear on gearbox shaft. Tighten in place.
8. Set gearbox levers properly, as shown on the data plate (left hand to C, right hand to B) and position tumbler to cut 24 t.p.i.
9. Check gear set-up by cutting 27 t.p.i. on scrap stock.

$$\text{In the case of 27 t.p.i.} = \frac{3 \times 24 \times 4}{14 \times 27} = \frac{32}{42} \frac{\text{Driver}}{\text{Driven}}$$

	LEVERS		THREADS PER INCH								
			SLIDING FEEDS IN INCHES-SURFACING				$\frac{1}{2}$ SLIDING				
	D	B	112	104	96	92	88	80	76	72	64
		.0017	.0018	.0019	.002	.0022	.0024	.0025	.0027	.003	
C	B	56	52	48	46	44	40	38	36	32	
		.0033	.0035	.0038	.004	.0043	.0047	.005	.0053	.006	
D	A	28	26	24	23	22	20	19	18	16	
		.0065	.007	.0075	.008	.0085	.0095	.010	.0105	.012	
C	A	14	13	12	$11\frac{1}{2}$	11	10	$9\frac{1}{2}$	9	8	
		.013	.014	.015	.016	.017	.019	.020	.021	.024	
WHEN USING 36 ^T DRIVER GEAR	C	A	7	$6\frac{1}{2}$	6	$5\frac{3}{4}$	$5\frac{1}{2}$	5	$4\frac{3}{4}$	$4\frac{1}{2}$	4
		.027	.029	.031	.032	.035	.038	.040	.042	.048	

FILL WITH SHELL TELLUS OIL 33 TO MARK ON SIGHT GLASS

OIL OBTAINABLE FROM SHELL OIL COMPANIES THROUGHOUT THE WORLD

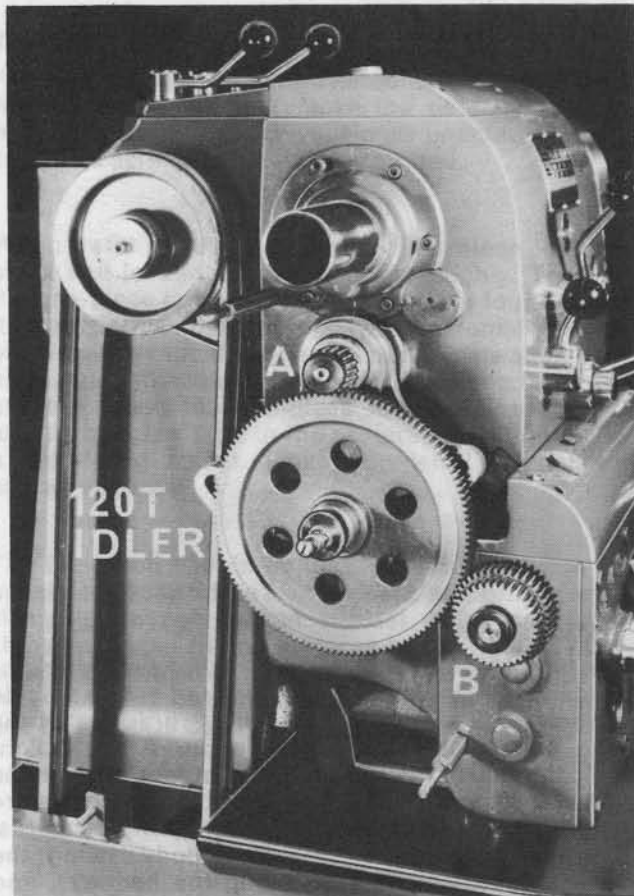

Metric Thread Cutting

Compounding of the quadrant idler gear is necessary for cutting all 21 available metric threads. For this machine replace the 120T idler with a compound 127T and 120T idlers on the quadrant.

1. Loosen quadrant locking nut located between quadrant and end of bed. Swing quadrant until 120T gear is out of mesh with gear on feedbox shaft.
2. Loosen idler gear stud nut located on inside of quadrant. Slide 120T gear away from gear on headstock shaft. Select proper gear for headstock shaft from chart, place gear in position and tighten knurled nut.
3. Remove 120T idler gear from brass sleeve. Place 127T gear on brass sleeve followed by 120T gear. Slide sleeve with compound 127T/120T gears on idler gear stud; be sure 127T gear is next to quadrant.
4. Slide 127T/120T gear up until 127T gear meshes with selected gear in position on headstock shaft. For correct mesh, place strip of heavy wrapping paper (.005 in. thick) between teeth of meshing gears. Paper should fit tight between gears. Lock gear stud in place and remove paper.
5. Place 18T gear in position on feedbox shaft next to feedbox. This gear is used as spacer only.
6. Select proper gear for this shaft position from chart. It will be 35T or 42T only. Place gear in position next to 18T gear spacer. Tighten in place.
7. Swing quadrant until 120T gear meshes with outer gear on feedbox shaft. Check gear mesh (step 4) and tighten quadrant locking nut.
8. Position feedbox levers as shown in chart. Check gear setup by cutting thread on scrap stock.

NOTE:

When cutting metric threads, THE THREADING DIAL CANNOT BE USED. Close half-nut for first cut, then reverse lathe to return carriage for each succeeding pass until thread is completed.

METRIC THREAD CUTTING

M/M Pitch	POS. (A)	POS. (B)	LEVER L.H.	POS. R.H.	TUMB. POS.
0.25†	18T	42T	D	B	3
0.35	21T	42T	D	B	6
0.5	36T	42T	D	B	3
0.6	36T	42T	D	B	6
0.7*	42T	42T	D	B	6
0.75	36T	42T	D	B	9
0.8	36T	35T	D	B	8
0.9	27T	42T	C	B	6
1.0	36T	42T	C	B	3
1.25	30T	42T	C	B	9
1.5	36T	42T	C	B	9
1.75*	42T	42T	C	B	9
2.0	36T	42T	D	A	3
2.5	30T	42T	D	A	9
3.0	36T	42T	D	A	9
3.5*	42T	42T	D	A	9
4.0	36T	42T	C	A	3
4.5	27T	42T	C	A	9
5.0	30T	42T	C	A	9
5.5	33T	42T	C	A	9
6.0	36T	42T	C	A	9
7.0*	42T	42T	C	A	9

Figure 1

* Requires extra 42T gear.

† Use 21T gear as spacer in place of 18T gear.

NOTE:- One each 18T, 36T, 42T, and 120T gears furnished with lathe.

Multi-Start Threads.

Multi-start threads may be cut in any one of three ways.

1. By re-positioning the compound slide one pitch forward for each start. It will be realised however, that the accuracy of this method depends upon the operator.
2. By using an accurately divided driver plate and turning the workpiece one division forward for each start.
3. By advancing the driver gear a calculated number of teeth to advance the spindle by one pitch of the thread to be cut. The accuracy of this method is that of the machine. To use this method the number of teeth on the driver wheel should be a factor of the number of starts to be cut: e.g. when cutting a 12 mm. pitch 4 start thread the 24T. driver gear is used; dividing 4 into 24 gives 6 which is the number of teeth to move the driver gear to obtain each start. To use this method, cut one start. Mark the meshing tooth on all gears then remove the idler gear. Turn the driver gear through the calculated number of teeth and replace the idler gear making sure that the meshing marks correspond exactly. Cut the next start and repeat for each remaining start.

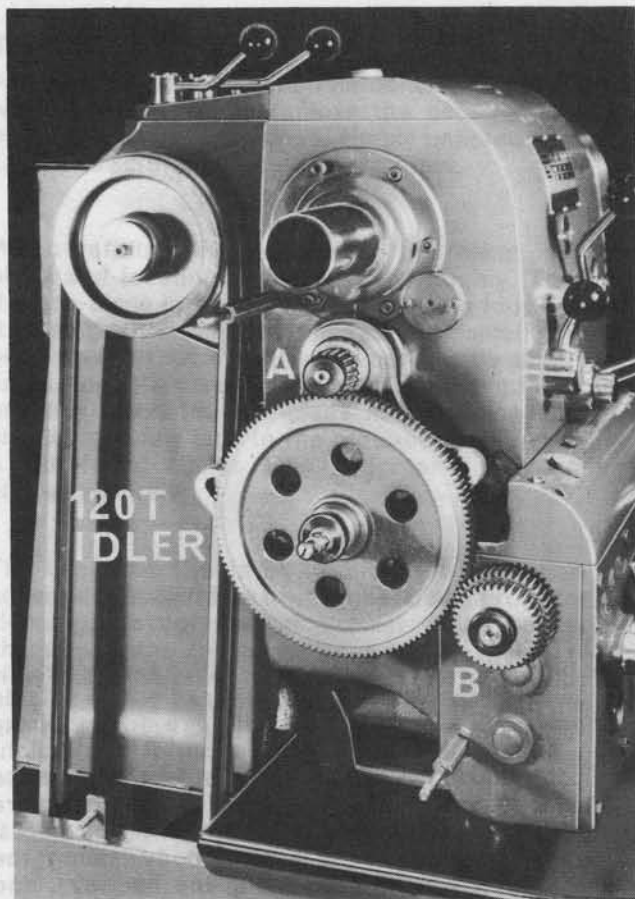

Metric Thread Cutting

Compounding of the quadrant idler gear is necessary for cutting all 21 available metric threads. For this machine replace the 120T idler with a compound 127T and 120T idlers on the quadrant.

1. Loosen quadrant locking nut located between quadrant and end of bed. Swing quadrant until 120T gear is out of mesh with gear on feedbox shaft.
2. Loosen idler gear stud nut located on inside of quadrant. Slide 120T gear away from gear on headstock shaft. Select proper gear for headstock shaft from chart, place gear in position and tighten knurled nut.
3. Remove 120T idler gear from brass sleeve. Place 127T gear on brass sleeve followed by 120T gear. Slide sleeve with compound 127T/120T gears on idler gear stud; be sure 127T gear is next to quadrant.
4. Slide 127T/120T gear up until 127T gear meshes with selected gear in position on headstock shaft. For correct mesh, place strip of heavy wrapping paper (.005 in. thick) between teeth of meshing gears. Paper should fit tight between gears. Lock gear stud in place and remove paper.
5. Place 18T gear in position on feedbox shaft next to feedbox. This gear is used as spacer only.
6. Select proper gear for this shaft position from chart. It will be 35T or 42T only. Place gear in position next to 18T gear spacer. Tighten in place.
7. Swing quadrant until 120T gear meshes with outer gear on feedbox shaft. Check gear mesh (step 4) and tighten quadrant locking nut.
8. Position feedbox levers as shown in chart. Check gear setup by cutting thread on scrap stock.

NOTE:

When cutting metric threads, THE THREADING DIAL CANNOT BE USED. Close half-nut for first cut, then reverse lathe to return carriage for each succeeding pass until thread is completed.

METRIC THREAD CUTTING

M/M Pitch	POS. (A)	POS. (B)	LEVER L.H.	POS. R.H.	TUMB. POS.
0.25†	18T	42T	D	B	3
0.35	21T	42T	D	B	6
0.5	36T	42T	D	B	3
0.6	36T	42T	D	B	6
0.7*	42T	42T	D	B	6
0.75	36T	42T	D	B	9
0.8	36T	35T	D	B	8
0.9	27T	42T	C	B	6
1.0	36T	42T	C	B	3
1.25	30T	42T	C	B	9
1.5	36T	42T	C	B	9
1.75*	42T	42T	C	B	9
2.0	36T	42T	D	A	3
2.5	30T	42T	D	A	9
3.0	36T	42T	D	A	9
3.5*	42T	42T	D	A	9
4.0	36T	42T	C	A	3
4.5	27T	42T	C	A	9
5.0	30T	42T	C	A	9
5.5	33T	42T	C	A	9
6.0	36T	42T	C	A	9
7.0*	42T	42T	C	A	9

Figure 1

* Requires extra 42T gear.

† Use 21T gear as spacer in place of 18T gear.

NOTE:- One each 18T, 36T, 42T, and 120T gears furnished with lathe.

Multi-Start Threads.

Multi-start threads may be cut in any one of three ways.

1. By re-positioning the compound slide one pitch forward for each start. It will be realised however, that the accuracy of this method depends upon the operator.
2. By using an accurately divided driver plate and turning the workpiece one division forward for each start.
3. By advancing the driver gear a calculated number of teeth to advance the spindle by one pitch of the thread to be cut. The accuracy of this method is that of the machine. To use this method the number of teeth on the driver wheel should be a factor of the number of starts to be cut: e.g. when cutting a 12 mm. pitch 4 start thread the 24T. driver gear is used; dividing 4 into 24 gives 6 which is the number of teeth to move the driver gear to obtain each start. To use this method, cut one start. Mark the meshing tooth on all gears then remove the idler gear. Turn the driver gear through the calculated number of teeth and replace the idler gear making sure that the meshing marks correspond exactly. Cut the next start and repeat for each remaining start.

SADDLE AND SLIDES

The saddle is of American winged type. It is secured to the bed by means of adjustable keep strips at front and rear and can be locked in any position on the bed by means of a locking clamp. The cross slide is graduated radially 90°-0-90° each side for accurate setting of the compound slide. Large diameter micrometer dials are graduated in 0.001 in. divisions on both the slides.

An American pillar-type toolpost is fitted as standard, intended for tools up to $\frac{5}{8}$ in. \times 1 in. A 'one-shot' lubrication system is fitted into the apron for force-feeding lubricant to the oil ways of the saddle and slides.

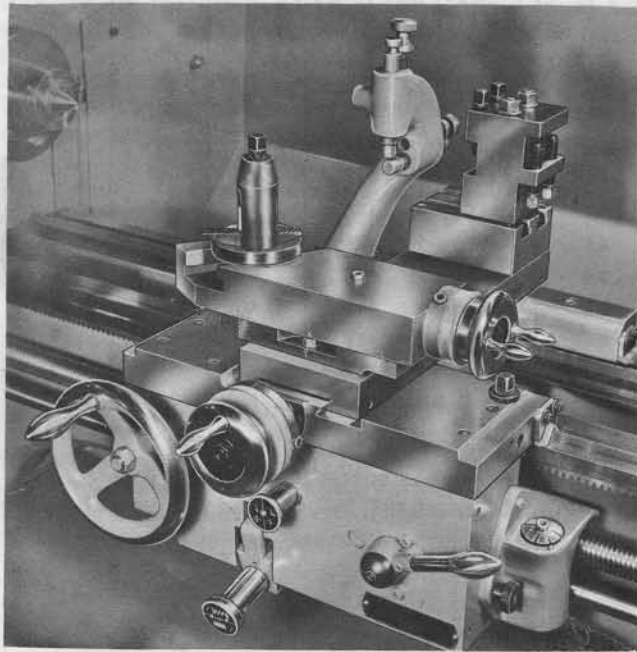

APRON

Longitudinal and cross-feeds are selected by means of a plunger (1) shown in the illustration. Longitudinal feeds are obtained with the plunger fully extended; cross-feeds with the plunger fully depressed. A central or neutral position is also provided which is selected when neither longitudinal nor cross-feed is required.

The feeds are engaged by lever (2) which incorporates a safety device to prevent overloading. This mechanism is pre-set at the Works to trip out at 450 lb end pressure. It should give long, trouble-free service.

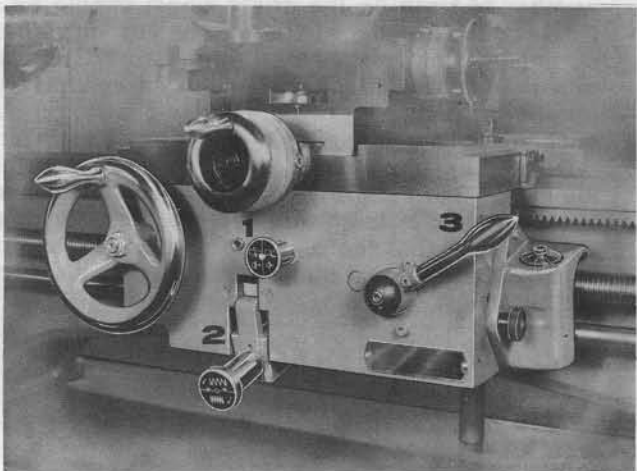

TAILSTOCK

The barrel is graduated in inch divisions and induction-hardened in the morse taper bore and on the outside diameter. All standard tang drills are driven by the tang and eject at zero graduation. A tool-height indicator line is marked on the front face of the nose chamfer to assist in setting tools to correct centre height when a workpiece is set up between centres. There are two parts to the tailstock body casting; the base proper, which slides along the bedways, and the tailstock body which may be moved laterally on the base. This movement or 'setting over' allows shallow tapers to be turned without need for a special taper attachment; maximum set over is $\frac{1}{2}$ in. each side of the centre line, a graduated scale is marked on the rear face of the tailstock casting. The tailstock is set over by first releasing the bedway clamping lever and then adjusting the two set-over screws fitted in the base (one at each side) for this purpose.

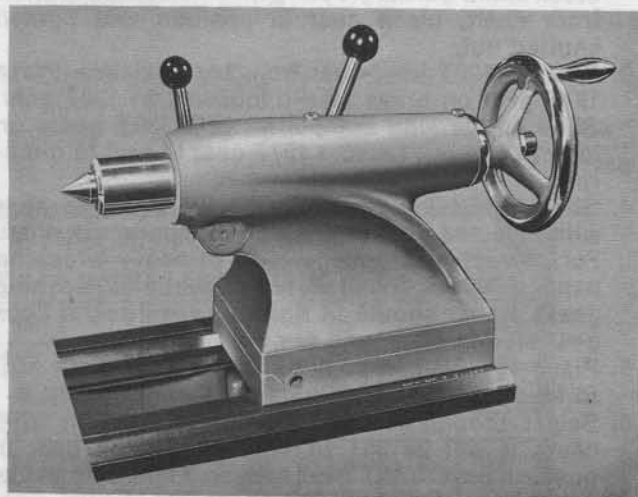

THE TWO SPRING-LOADED SHOULDER BOLTS HOLDING THE BASE TO THE BODY DO NOT REQUIRE SLACKENING AT ANY TIME.

Quick lever clamping is employed to lock the tailstock in position on the bedways. The tailstock barrel is locked at the required setting by a lever operated

The Bed

All lathe beds are induction hardened and ground on working surfaces. To remove the detachable gap-piece on gap bed machines, simply unscrew the four cap-head screws. No dowels are fitted.

When refitting the gap-piece, first clean off the block and locating faces most thoroughly. Then fit the gap-piece in position and locate the four screws (two vertically from the top, two horizontally). Now bring up the saddle to give an approximate alignment and tighten the screws lightly. If the mating faces are properly clean the gap-piece may now be aligned exactly by a few taps in the required direction using a hide-faced mallet. Finally tighten the retaining screws securely.

The lathe bed should be cleaned down as often as possible to keep it free from chips. Use a brush for all cleaning; do not use an airblast which can drive chips under the sliding surfaces and may, also, blow away the protective oil film from working surfaces. After cleaning down, the bed should be coated with Shell Tellus Oil 33 to prevent formation of rust.

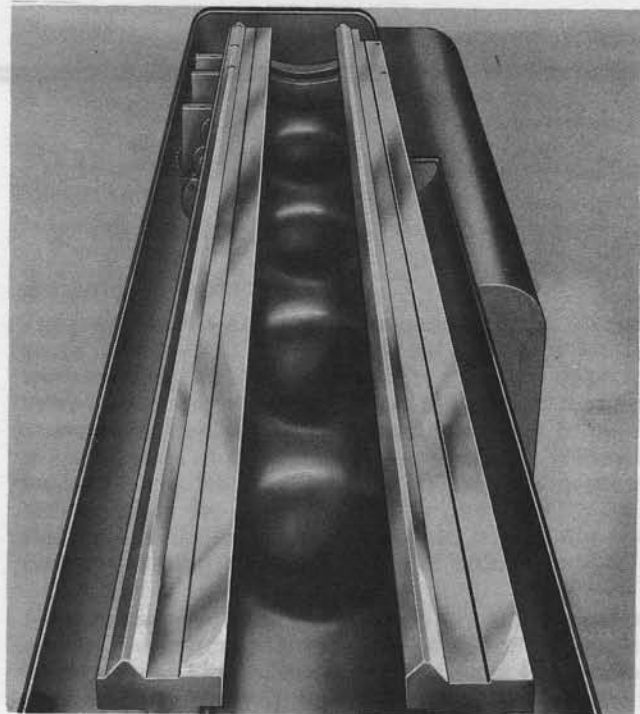

ACCESSORIES

A comprehensive range of accessories is available for the Clausing-Colchester lathe, specifically designed for the machine and engineered for robust service and reliability.

A brief list of these is given below and more detailed information on certain items is given in subsequent pages. All accessories listed can be fitted to the machine after it has left the Works.

<i>Description</i>	<i>Code</i>
3-jaw Universal scroll chuck—9 in.	15-401
4-jaw Independent chuck—12 in.	15-402
21 in. Faceplate (gap bed lathes only)	15-403
Coolant system	15-408
Steady rest	15-410
Reversing switch	15-412
One-position carriage stop	15-414
Five-position carriage stop	15-416
Rear toolpost	15-418
Chuck backplate	15-417
Telescopic taper attachment	15-413
High-speed threading unit	15-427
Rotating centre	15-421
Hex bed turret	15-404
Micro carriage stop	15-4000
Turret toolpost	15-4½-R
Hydraulic profiling attachments	
(15 in x 30 in lathes)	15-330
(15 in x 48 in lathes)	15-331

ACCESSORIES

COOLANT SYSTEM

The cabinet base has a built-in storage tank with a pump fitting position already provided. A pipe in the centre of the tray returns coolant to the tank and a gauze strainer is fitted to the pipe at tray level to prevent swarf and chips from entering the tank.

The jointed piping supplied with this unit is fully universal and will feed coolant to any required position. Supply of coolant is easily controlled by a ball-type shut-off valve. The whole system has been designed to eliminate the leaks usually inherent in other coolant systems. Capacity of the unit is $5\frac{1}{2}$ gallons. An electric pump of robust and reliable design is available and is wired into the main electrical panel at the main switch (see Wiring Diagram). The pump motor should never be run if the coolant tank is dry. The tank should be cleaned at frequent intervals and refilled with fresh coolant. Precautions should be taken when refilling to avoid splashing the coolant over the pump.

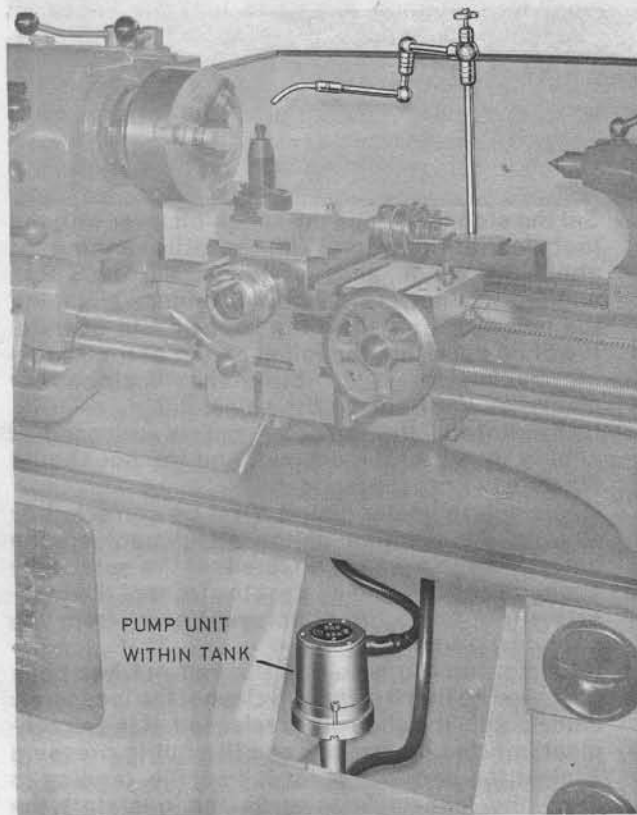

Soluble oil emulsions

For most work a soluble oil emulsion will be chosen, since this will almost always be adequate for the work in hand, and preferred by the machine operator. When screwing with a die-head, tapping, or reaming, some extra coolant applied locally may be required. If much work of this type is contemplated, it may be better to use an emulsion of an extreme pressure soluble oil in the machine tank. A good quality oil of this type will give results equal to neat cutting oil whilst retaining the cleanliness of soluble oil.

Good quality soluble oils should always be chosen and mixed in accordance with the suppliers' recommendations. The following grades have been tested and used in our own works with complete satisfaction:-

Shell Dromus Oil B—conventional milky soluble oil mixed with water in the ratio 25/30: 1.

Shell Dromus Oil D—translucent soluble oil mixed with water in the ratio 40: 1.

Shell Dromus Oil 908—extreme pressure oil mixed with water in the ratio 10/15: 1.

Soluble oils and machine maintenance

No soluble oil emulsion, however good, can completely prevent rust without help from the operator. The machine should therefore be cleaned down regularly and bright parts wiped over with machine oil. It should never be left, especially over weekends or holidays, with wet swarf on the bed or slides. When the work in hand requires the saddle or tail-stock to be clamped in one position for long periods it is advisable to spread a little machine oil on the bed beforehand to ensure a film of oil between the surfaces.

The tank should be emptied, cleaned out and refilled with fresh soluble oil at regular intervals.

HIGH-SPEED THREAD CUTTING UNIT Introduction

This attachment is designed to replace the existing screwcutting mechanism of the lathe. It is secured to the right hand side of the lathe apron by socket head screws and accurately positioned by dowels.

The attachment contains its own half-nut mechanism and obviates any possibility of the thread being picked up incorrectly. A threading dial is eliminated; the operator merely presses on the handle and the half-nut will engage at the correct point to pick up all English threads, including fractional threads per inch.

Once fully engaged, the half-nut is locked positively in mesh with the lead screw and always at precisely the same depth of engagement until disengaged automatically or manually.

When the knock-off lever encounters the stop which is fitted to the lathe bed, the half-nut is disengaged automatically, safely and with great accuracy.

As engagement of the half-nut is controlled and release is automatic, threads can safely be cut at high spindle speeds, the only limiting factors being considerations of tool life and the speed at which the carriage can be picked up without undue strain on the lathe mechanism.

Where the attachment is not already fitted to your lathe, refer to the Mounting Instructions before proceeding.

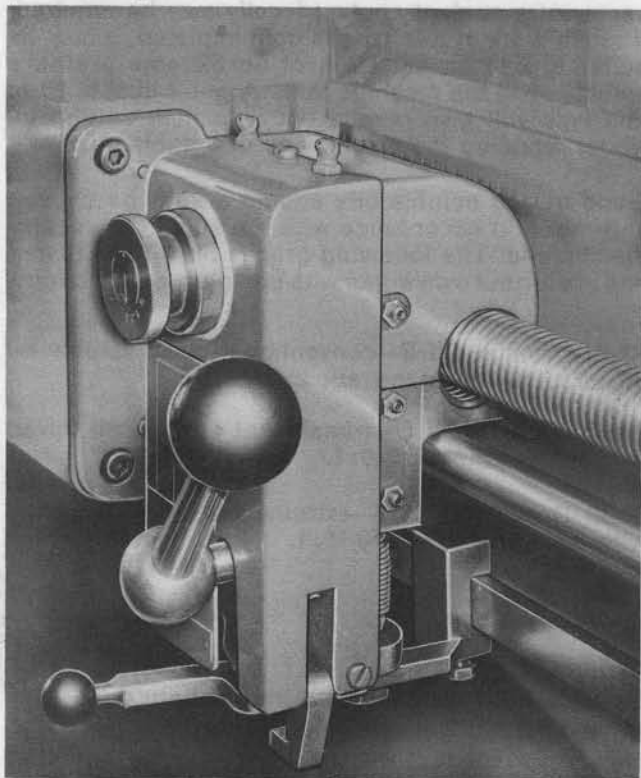

Setting and Operation

The setting dial can be pulled out and turned to four different positions, the settings being as follows:

- 0—"Safe". Impossible to engage half-nut with lead screw.
- 1—Odd-quarter threads per inch (e.g. $4\frac{3}{4}$).
- 2—Odd-half threads per inch (e.g. $4\frac{1}{2}$).
- 4—Whole numbers of threads per inch (e.g. 8 or 13).

Move the knock-off control to the "Screwcut" position and set the adjustable stop to engage the knock-off lever so the half-nut is disengaged at approximately the required position. Now, with the tool clear of the work and the lathe running, engage the half-nut and allow the knock-off to operate. Fine adjustment may then be made by using the compound slide.

Threads may be cut either by feeding the tool straight in or by using the top slide at half the thread angle. When using the latter method, however, allowance must be made for the fact that the tool will have moved forward by half the pitch when the thread is completed. The tool may be allowed to form its own annular groove at the end of the cut, but should be withdrawn without delay to avoid rubbing.

It is important that the lead screw be clean and free from swarf for high speed screw cutting.

INSTRUCTIONS FOR FITTING NEW HALF NUT

Access to the screws securing the half nut is through two holes in the main casting of the attachment.

IT IS IMPORTANT to check that synchronisation of the nut and pinion is correct and, if necessary, adjustment must be made as detailed in the Maintenance section.

MOUNTING INSTRUCTIONS

1. Remove covers from the High Speed Threading unit.
2. Remove threading dial from carriage apron.
3. Loosen steady adjusting nut (B) and slide steady (C) up slightly.
4. Fit threader over lead screw, near the tailstock end of the lathe and hold in place. Engage threader half nut (E).
5. Move carriage back until it contacts face of threader. Attach threader to apron with three mounting bolts (A). Tighten bolts just enough to hold while aligning threader.
6. Ensure half nut is fully engaged with lead screw by applying gentle pressure upwards (taking care not to deflect leadscrew). Tighten bolts (A).
7. Position Steady (C) so that it just clears lead screw (.003 in. maximum); tighten steady adjusting nut (B).
8. On 17 in. lathes only, adjust lower steady (located next to apron) to bear lightly on underside of leadscrew.
9. Position stop bar (H) below knock-off lever (F) (about $\frac{1}{8}$ in. clearance) and parallel to feed rod. Locate mounting holes on lathe bed drill and tap $\frac{1}{8}$ in. UNC for mounting screws.
10. Attach stop bar to bed using flat head machine screws and spacers provided.
11. **Note:** When knock-off lever (F) is in "screwcut" position (i.e. knob moved to left) the knock-off lever should engage the stop (K) by approximately $\frac{5}{16}$ in. and when in the "lock" position (i.e. moved to right) it must be clear of the stop. Make any adjustment necessary by altering length of knock off lever or stop bar spacers.
12. Check the correct fitting of the threading unit as follows:—

Set the stop to engage the knock-off lever with the tool clear of the work. With the lathe running at about 300 r.p.m. and set to cut say 12 T.P.I., engage the nut, as described under "engaging the half-nut" and allow the knock-off to operate. It will be seen that the initial action of the knock-off mechanism is to rotate the locking lever clockwise and release the selector pin.

Immediately the selector pin is released it should fly out of the dial slot and the nut should disengage from the leadscrew.

If this action is sluggish it must be corrected by altering the position of the attachment on the apron in such a way to ensure that the nut is fully engaged and bearing against the front of the leadscrew (i.e. move the attachment away from the operator).

It is important to note that the half-nut has been designed so that it is thrown clear of the leadscrew immediately the slide pin is released. If the attachment is fitted incorrectly and the nut is pressing against the back of the leadscrew (i.e. tending to bend the leadscrew towards the operator) the servo action will not operate and the release mechanism is liable to act sluggishly.

This fault can be easily discovered by observing the slide pin when the knock-off mechanism

operates with an increased load applied to the carriage by applying slight hand pressure to the traversing hand wheel. If the slide pin flies out of the dial slot **immediately** it is released the action is satisfactory, but if there is a slight pause the servo action is not operating and the nut is being forced out of engagement with the leadscrew by the safety device incorporated in the attachment.

13. After any necessary adjustments have been made, and repeated trials show that the attachment is working satisfactorily, drill dowel holes in lathe apron through holes "G" in threader, ream to dowel size and fit dowels.
14. Replace the covers and the attachment is ready for operation.

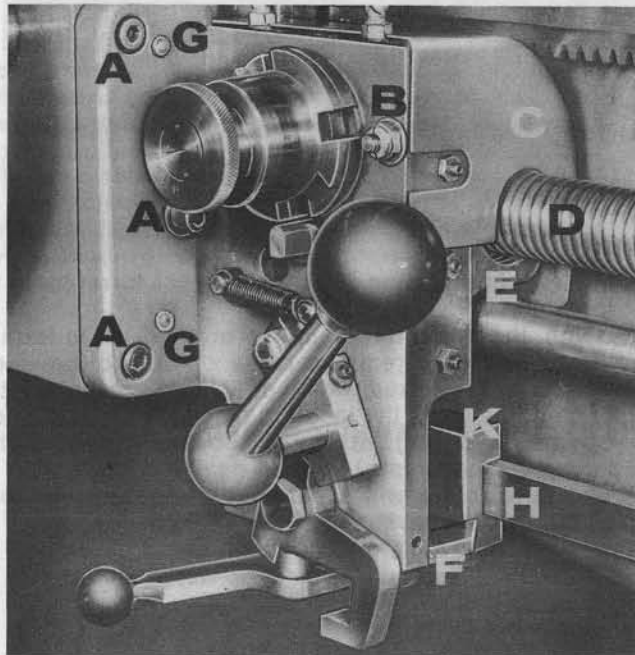

Engaging the Half-Nut

With the lathe running at the required speed, hold down the handle with a steady pressure. Engagement will not be possible until the right moment, which is indicated by a movement of the handle. At this moment the handle should be fully depressed and pressure released. If the half-nut is not properly locked in engagement, the handle will fly back and the procedure should be repeated.

The handle must be held down firmly and steadily until the half-nut engages; it should not be depressed intermittently or engagement will be delayed.

Pressure on the handle *must* be released on engagement.

Before screw cutting, it is recommended that the operator carry out a few runs with the tool clear of the work to get the "feel" of the mechanism.

Manual Release

If it is required to cut a thread without using the automatic knock-off, the half-nut can be disengaged manually.

Safety Lock

If it is required to advance the carriage beyond the stop, this may be done without interfering with the setting, by moving the knock-off control to the "lock" position. It will then be retained in a position which will allow the stop to be by-passed, at the same time locking the attachment so that it will not be possible to engage the half-nut until the knock-off control is returned to the "screw cut" position.

Left Hand Threads

Left hand threads should be cut by reversing the lathe and inverting the tool. The lead screw can then be set to run in the normal direction of rotation and the automatic knock-off can be used. If a screw-on chuck is used, care must be taken, of course, to ensure that it does not unscrew while running.

Lubrication

Medium lubricating oil, not grease, should be used at the points indicated.

The double ball bearing on the pinion shaft is packed with grease and will not require attention.

Maintenance

Adjustment for wear in the half-nut slide is by three socket head screws with lock nuts operating on a gib on the right hand side of the attachment. It is essential, however, that this slide works freely over the full range of its travel.

Initially the attachment will either be fitted by a trained service engineer, or will be supplied with the mounting bracket drilled to correspond with existing locations on the lathe apron, but the following points should be noted:

1. When the half-nut mechanism is locked in engagement, the half-nut should be deeply meshed and the steady set to prevent the lead-screw distorting upwards. Periodically, the steady should be checked for wear and the surface cleaned up by filing and scraping. (In the case of the 17 in. lathe attachment a further steady is fitted to support the lead-screw and should bear lightly on the underside of the lead-screw.)
2. The half-nut should not bow the lead screw horizontally, a slight deflection away from the attachment is acceptable, but there must be no deflection towards the attachment.
3. With the cover of the attachment removed, it will be seen that a pin enters one of the slots in the control disc when the half-nut is engaged. With back lash taken up, this pin should be approximately central in the slot, with a slight bias towards the side of the slot nearest the mounting flange of the attachment. On no account must it bear against the side of the slot.

Should this fault develop through wear, it may be corrected by re-synchronizing the pinion as follows: Withdraw the pinion from the shaft after removing the retaining screw. The pinion is located on the driving collar by a pin which will engage any one of a series of holes arranged to give a vernier action. By moving the pinion round one hole at a time, the best position can be found by trial and error. A second pin, fitted to the reverse side of the pinion, may be used to give a further set of positions if necessary.

No other adjustment should be attempted without consulting the suppliers and the serial number of the attachment must always be quoted in case of difficulty or when ordering replacements.

STEADY REST

Of extremely rigid design, this attachment is very easily opened and set. Three adjustable fingers are provided, and the maximum capacity is 5 in. bar diameter.

Inserts are of sintered bronze and quickly replaced, being a press fit into the ends of the fingers.

The whole attachment is readily attached to the bed by a clamp bolt, and can be removed very rapidly when not required for use.

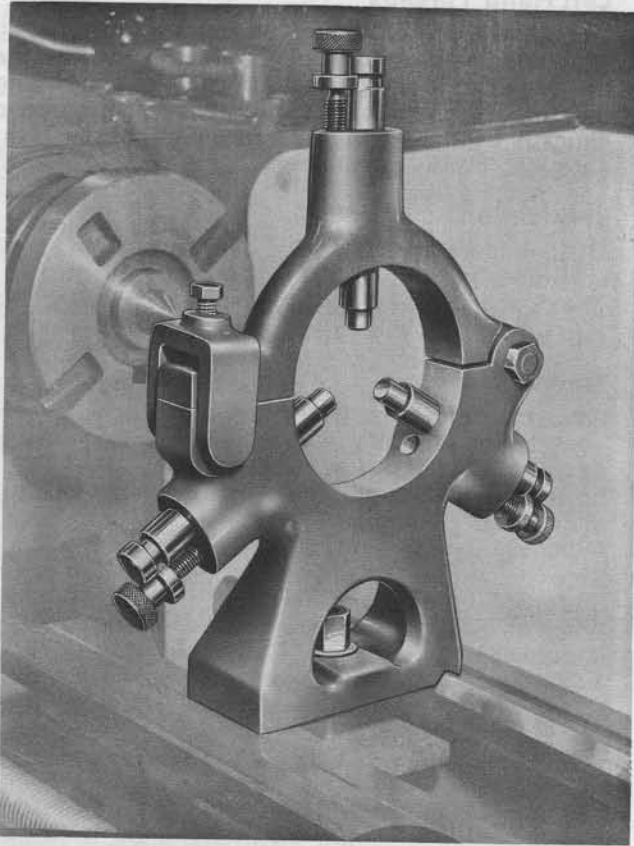

REAR TOOLPOST

As an aid to production, a rear toolpost is available for fitting direct to the cross slide, which is drilled and tapped ready to receive it.

Two tool positions are provided so the tool may be fitted either in conventional manner, or in the inverted position.

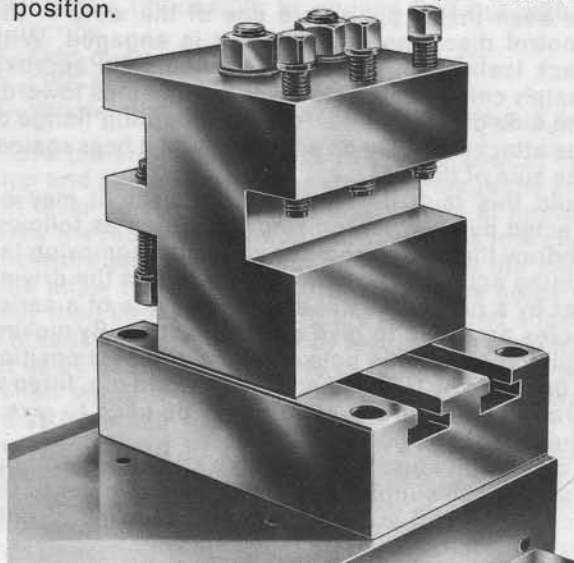

Using this tool post (with the tool fitted in conventional manner) left hand threads can be easily cut.

Supplied complete with all necessary fixing screws, the only fitting required is the physical bolting of base pad to cross slide. Tee slots are provided in the base pad so that the toolpost may be adjusted in position on the base. Maximum tool depths that can be accommodated in either position are $\frac{3}{4}$ in.

Standard wrenches and Allen keys supplied with the machine will fit all the nuts and screws in this assembly.

SQUARE TURRET TOOLPOST

To index the toolpost into any of four operating positions, the central hand lever is moved in an anti-clockwise direction until distinct detents are felt. This indicates that the plunger mechanism has released the locating plunger and the indexing mechanism is engaged. When the central hand lever is returned in a clockwise direction the turret will index into the next position. A further short movement of the lever in the same direction will lock turret block to topline.

Using the retracting plunger method of indexing, the turret block remains close on its bottom face whilst being indexed, which effectively prevents entry of chips between the locating faces. The turret block can also be swung into any position without use of the indexing mechanism.

The turret block will accommodate up to four tools or toolholders having a height up to $\frac{3}{4}$ in.

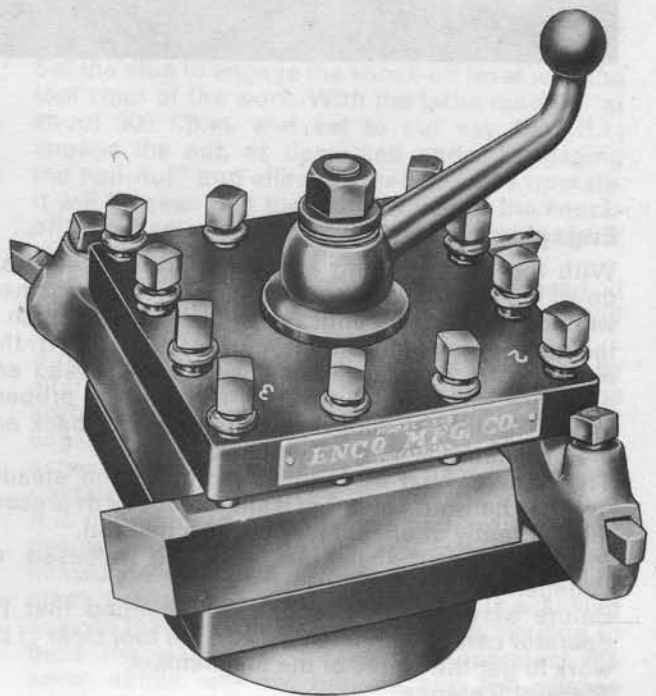

Bed Stops

To provide accurate and reliable means of repeating shoulder lengths, a single-type bed stop or five-position turret type bed stop are available as extra equipment. With these units, the saddle may be stopped in any desired position without detrimental effect on the feed mechanism.

A micro carriage stop is also available, for clamping on the front of the bedway. Micrometer control is graduated in 0.001 divisions. Hardened stop locks securely in any position.

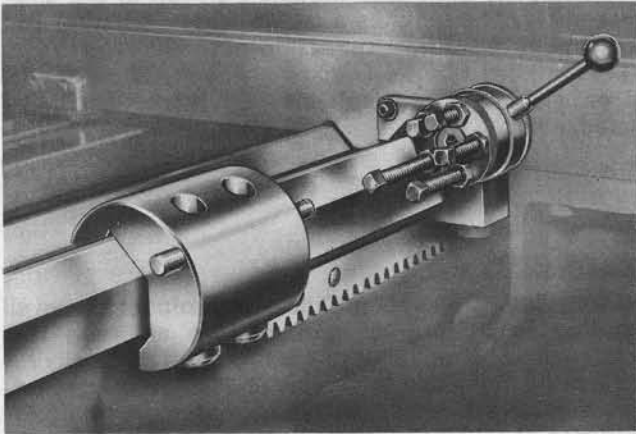

TELESCOPIC TAPER TURNER

This attachment can be used for producing tapers up to 10° in either direction. It can be mounted directly onto the rear of the saddle without any modification other than the fitting of a new saddle screw and nut which is supplied with the unit.

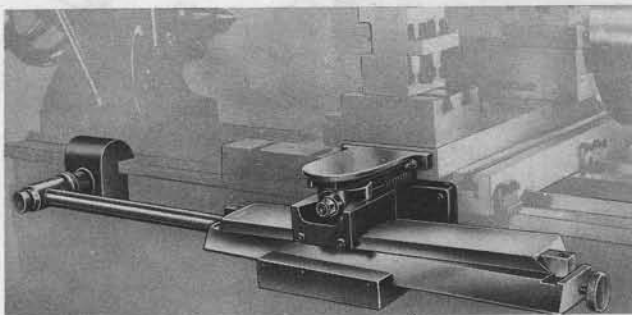

The swivel slide is graduated in $\frac{1}{4}^\circ$ of arc and in $\frac{1}{8}$ in. taper per foot and great sensitivity of control is obtained when setting a taper by the use of the micro adjustment screw.

The cross slide handwheel is always used to control the tool and the base slide can be adjusted along the bed so that the taper may be cut in any position.

The attachment will deal with a length of 14 in. of taper at any one setting.

After attaching to the machine, all that is required to prepare the taper turner for use is the clamping of the connecting rod in the anchor bracket by means of the cap head screw.

The fitting of this attachment in no way detracts from the use of the machine as a normal centre lathe. Change over can be accomplished simply by loosening the connecting rod clamping screw and traversing the saddle towards the headstock to disengage the connecting rod from the clamp. Then remove the anchor bracket from the bed so that there is no obstruction to foul the connecting rod. By replacing the bracket and engaging the connecting rod, the taper turner is rapidly reset for use.

Great care should be taken when re-adjusting or altering the fit of the base slide in the taper turner bracket, as any slackness will result in incorrect tapers.

To fit the taper turner:

1. The saddle and cross slide are ready drilled to receive the attachment, the necessary holes being drilled and tapped during manufacture.
2. Clean down the rear end of the saddle to receive the taper turner bracket.
3. Release the locknut in the centre of the cross slide handwheel.
4. Slide the cross slide to the rear of the saddle.
5. Remove the saddle screw nut fixing bolt and withdraw the screw and nut from the rear end.
6. Insert the taper turner saddle screw and nut and secure the nut with the fixing bolt.
7. Pull the cross slide forward and engage the saddle screw in the handwheel pinion. (NOTE: The lock nut from the original saddle screw is not replaced, but should be retained in case it is needed when refitting the original screw.)
8. The slide block assembly can now be fitted to the thrust block on the rear of the saddle screw assembly. Engage the slides in the bracket and the slide block assembly on the slides. This will enable the bracket to be bolted to the rear of the saddle using the pre-tapped holes provided.
9. Finally, bolt the bottom slide extension piece to the rear of the bottom slide. Fit the connecting rod to the taper turner slide and the connecting rod clamp to the machined face on the back of the bed.

HYDRAULIC PROFILER

COLCHESTER SERIES '300' HYDRAULIC PROFILING UNIT

Designed to permit faster and more accurate profiling, this unit can be fitted at any time to Colchester lathes without modification or alteration of the machine. The standard equipment unit comprises four basic sub-units; profile slide, tool box, the rear beam and tail-stock units (suitable for round or flat masters or models) and a free-standing hydraulic power unit complete with a set of hoses. Two further units are available as additional equipment; a turret stop assembly and a facing beam; both of which are described subsequently.

Profile slide

Mounted directly on the rear of the lathe cross slide, this is an integral unit comprising the operating cylinder, cartridge-type servo valve, stylus lever mechanism and a swivelling Colchester Multi-type toolpost complete with one turning tool holder.

The complete unit can be fitted in four alternative positions; at 90°, 60°, 30° or parallel to the centre-line of the lathe. Maximum and minimum profiling angles obtainable for each of these positions are shown on the installation drawing. A copying accuracy of ± 0.0005 in. (0.01 mm) can be achieved; the change in copy diameter at 90° is 5½ in. (140 mm) and at 60° is 5 in. (127 mm).

The main control valve is a self-contained cartridge unit secured into the profile slide casting. The stylus is mounted on the lower end of the stylus lever shaft which is retained in the outer end of the stylus lever. Height and angle of the stylus in relation to the model master is easily adjusted by hand after releasing the clamp bolt. A combined ON/OFF lever and forward feed-velocity control is mounted on top of the slide assembly. The ram has a stroke of 3 in. (76 mm) and maximum approach/retraction speed of 110 in. (279 mm) per minute. The low stylus pressure of only 6 oz. (17 g) permits soft masters or models to be used, if necessary.

Toolbox

A swivelling Colchester Multi-type toolpost allows all tooling to be pre-set and enables all such tool changes to be made rapidly without the necessity for re-setting the slide assembly. Sufficient height adjustment is provided to permit the tool to be set up for forward or reverse cutting. Tools are carried in interchangeable toolholders; and when each tool has once been set to centre height it may be removed and replaced any number of times without alteration of the setting.

The toolbox is fitted on a base plate located at the front of the profile slide unit and can be mounted at four alternative positions, governed by the angle of the slide unit to the centre line of the machine. An adjusting handwheel is fitted which, through spiral gearing, provides micrometer control of the depth of cut up to ½ in. (13 mm) movement of the tool box along the base slide.

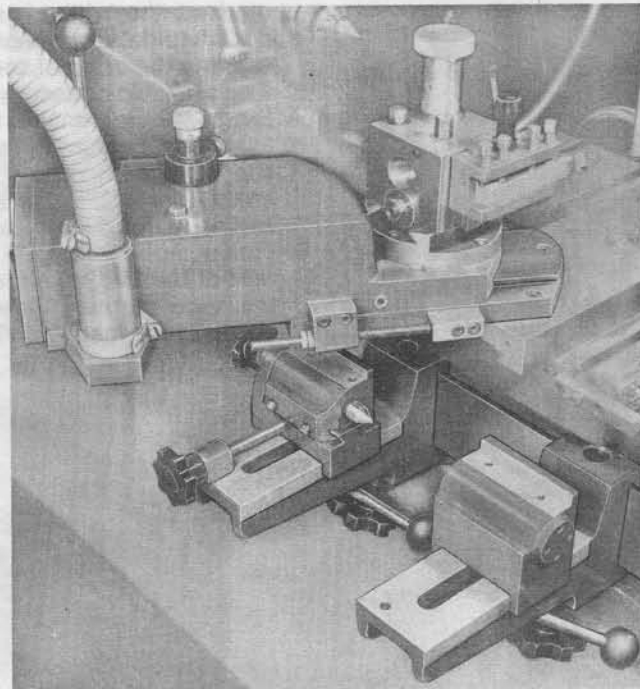

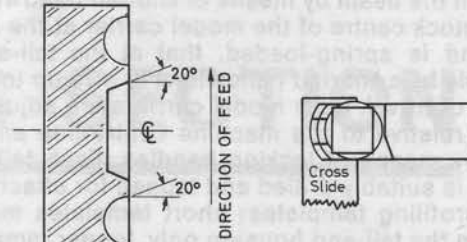
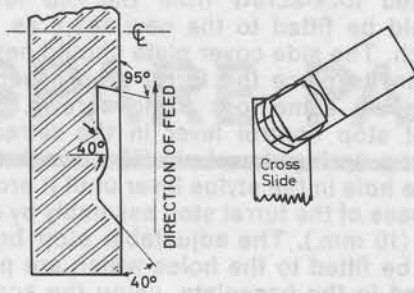
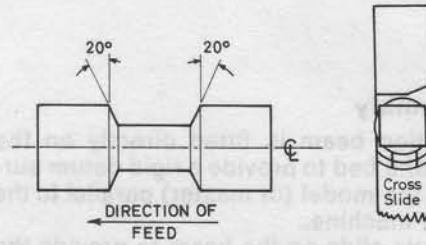
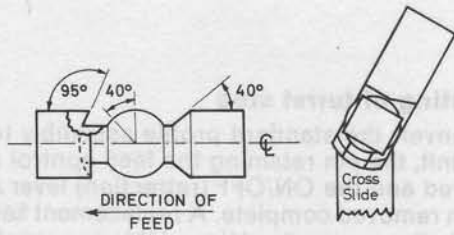

SLIDE POSITION CHART

ASSEMBLING HYDRAULIC PROFILING ATTACHMENT TO LATHE

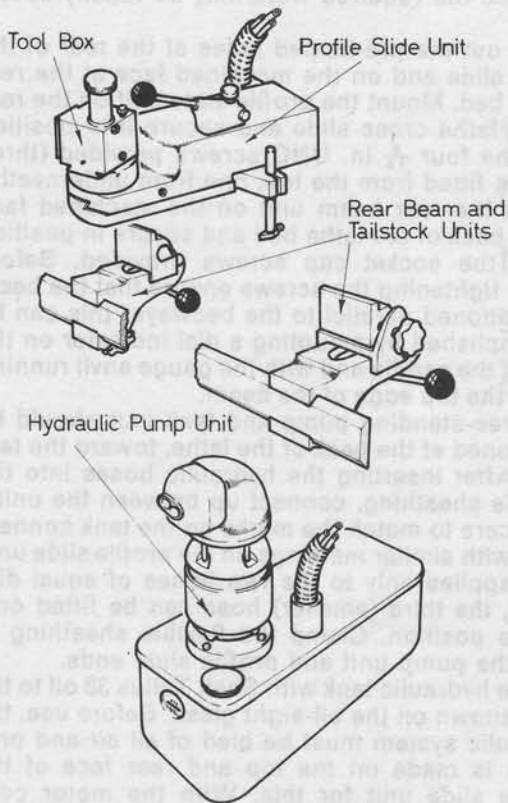

HYDRAULIC PROFILING UNIT

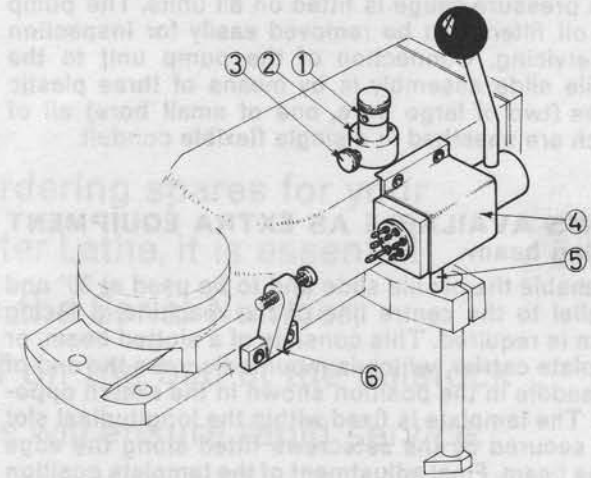

TURRET STOP ASSY.

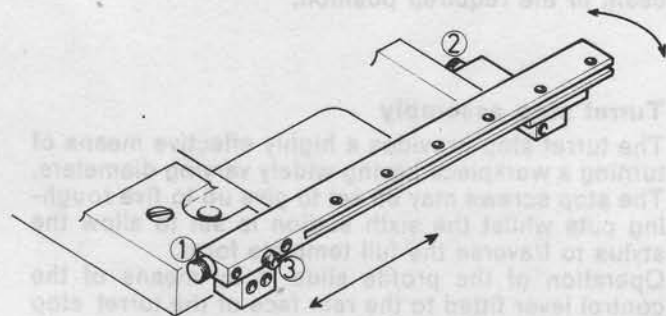

FACING BEAM ASSY.

Rear beam assembly

The dovetail-section beam is fitted directly on the rear face of the lathe bed to provide a rigid datum surface for carrying the model (or master) parallel to the centre-line of the machine.

Two beam-brackets slide on the beam to provide the locating surface for two tailstock-type model carriers which can accommodate either round master profiles or flat templates. Both brackets are mounted and locked on the beam by means of knurled handwheels. The tailstock centre of the model carrier at the headstock end is spring-loaded, that at the tail-end is adjustable by a knurled handwheel to give up to $2\frac{1}{2}$ in. (64 mm) of travel. Both model carriers are adjustable laterally relative to the machine centre-line and are locked by means of locking handles. Each tailstock housing is suitably drilled and tapped for attachment of flat profiling templates; short templates may be bolted on the tail-end housing only, longer templates should be supported at both housings. When the template is produced for support at both housings, the clamp-bolt holes should be made slightly elongated to permit small transverse adjustments.

Hydraulic power unit

This is a free-standing, combined tank and pump unit; designed to fit neatly at the back of the lathe. The motor unit is flange-mounted vertically upon the cover of the hydraulic tank. The electric pump works on $\frac{1}{2}$ h.p. producing a working pressure of 300 lb/sq. in. A pressure gauge is fitted on all units. The pump and oil filters can be removed easily for inspection or servicing. Connection of the pump unit to the profile slide assembly is by means of three plastic hoses (two of large bore, one of small bore) all of which are sheathed in a single flexible conduit.

ITEMS AVAILABLE AS EXTRA EQUIPMENT

Facing beam

To enable the profile slide unit to be used at 30° and parallel to the centre line of the machine, a facing beam is required. This consists of a slotted beam, or template carrier, which is mounted across the end of the saddle in the position shown in the sketch opposite. The template is fixed within the longitudinal slot and secured by the setscrews fitted along the edge of the beam. Final adjustment of the template position is made by setting the whole assembly over by means of the two micrometer adjusting screws (1 and 2). Screw No. 1 provides adjustment in a transverse plane whilst No. 2 varies the angle of the beam relative to the centre line of the machine. A pair of thumb-screws (3) are provided for locking the facing beam in the required position.

Turret stop assembly

The turret stop provides a highly effective means of turning a workpiece having widely varying diameters. The stop screws may be set to give up to five roughing cuts whilst the sixth station is set to allow the stylus to traverse the full template form.

Operation of the profile slide is by means of the control lever fitted to the rear face of the turret stop unit and movement of the lever to the left (towards the profile slide) brings the next turret stop screw round to the contact position and advances the unit. Movement of the lever to the right, or away from the

Mounting of turret stop

To convert the standard profile assembly to a turret stop unit, the pin retaining the feed control dial (1) is removed and the ON/OFF (retraction) lever assembly is then removed complete. A replacement keep is provided in the conversion kit; and this one must be fitted in place of the cam beneath the lever housing. Use the same two securing screws, however. The dial nut should then be re-fitted and pinned in position. The knurled lock-screw from the old lever assembly should be fitted to the new keep, as shown in the sketch. The side cover plate should next be removed and in its place the turret stop assembly is fitted, using the same four fixing screws. Now with the turret stop control lever in the retracted position, insert a spring dowel pin (5) through the underside of the hole in the stylus lever until it projects through the base of the turret stop assembly by approximately $\frac{3}{8}$ in. (10 mm.). The adjustable stop bracket (6) can now be fitted to the holes which are pre-drilled and tapped in the baseplate, using the screws provided in the conversion kit.

ASSEMBLING HYDRAULIC PROFILING ATTACHMENT TO LATHE

By consulting the chart shown in the sketches, the most suitable position for the profile slide assembly to produce the required work may be readily ascertained.

1. Clean out the pre-tapped holes at the rear of the cross slide and on the machined face at the rear of the bed. Mount the profile slide unit on the rear of the lathe cross slide and secure it in position with the four $\frac{5}{16}$ in. UNC screws provided (three screws fitted from the top, one from underneath).
2. Mount the rear beam unit on the machined face at the back of the lathe bed and secure in position using the socket cap screws provided. Before finally tightening the screws ensure that the beam is positioned parallel to the bedways; this can be accomplished by mounting a dial indicator on the rear of the saddle and with the gauge anvil running along the top edge of the beam.
3. The free-standing pump and tank unit should be positioned at the back of the lathe, toward the tail-end. After inserting the hydraulic hoses into the flexible sheathing, connect up between the units. Take care to match the marks on the tank connections with similar markings on the profile slide unit. This applies only to the two hoses of equal diameter, the third (smaller) hose can be fitted only in one position. Clamp the flexible sheathing at both the pump unit and profile slide ends.
4. Fill the hydraulic tank with Shell Tellus 33 oil to the level shown on the oil-sight glass. Before use, the hydraulic system must be bled of all air and provision is made on the top and rear face of the profile slide unit for this. With the motor connected up switch on the pump, check that the control lever is at the OFF or retracted position, then partially unscrew the rear bleed plug. When all air and bubbly oil has been expelled through the bleed plug, screw it up tight. Set the control lever now in the ON or contact position and repeat the procedure to expel all air through the top bleeder plug.

SPARE PARTS SECTION

When ordering spares for your Colchester Lathe, it is essential to quote the Serial Number, stamped on the bed at the tailstock end. This will ensure rapid service.

HEADSTOCK (A.F.) Shaft and Gear Assemblies

Ref. DWG. TRI/AFI/64-M

Item No.	Description	No.off.	Item No.	Description	No.off.	Item No.	Description	No.off.
1	Driving Shaft (Electric Clutch)		38	Back bearing inside cover	1	816	Brake shoe spring	2
2	Clutch driving shaft (19T)	1	39	Back bearing outside cover	1	857	Flanged bearing oil ring	1
3	Bearing-removal washer	1	40	Spindle end screwed collar	1	887	Needle bearing for Pt. 13	2
4	Driving shaft collar	1	41	Thrust ring	1	998	Brake shoes (pair)	1
5	Flanged bearing-housing	1	42	Spindle reverse gear (41T/41T)	1		Second Shaft	
7	Fulcrum stud	1	43	Small clutch gear (54T)	1	004	Second shaft keys	2
8	Fulcrum stud bush	1	44	Centre clutch	1	005	Second shaft key	1
9	Clutch expanding lever	1	45	Large clutch gear (72T)	1	026	Oil rings for bushes	2
10	Flanged bearing gasket	1	89	Back bearing spring	16	189	Needle bearing for Pt. 25	2
11	Driving pulley	1	90	Back bearing cover gasket	1	200	Screwed collar retaining screws	1
12	Pulley retaining washer	1		Reverse Shaft		224	Screwed plug retaining screws	1
13	Driving shaft	1	46	Reverse shaft	1	608	Retaining pin for Pt. 26	1
14	Driving shaft washer	1	47	Flanged bearing	1	897	Needle bearings for Pts. 20 & 22	2
15	Driving shaft bush	1	48	Reverse shaft washer	1		Main Spindle	
16	Screwed plug for bush Pt.15	1	49	Shear pin sleeve	1	007	Reverse gear driving key	1
17	Driving shaft gear (46T)	1	50	Change gear (21T)	1	224	Key retaining screws	2
18	Driving shaft gear (25T/31T)	1	51	Reverse shaft knurled nut	1	227	Retaining screws for Pts. 32 & 39	2
19	Second shaft	1	52	Shear pin	1		Retaining screws for Pt. 37	3
20	Second shaft bush L/H	1	88	Reverse shaft gear	1	231	Lock screws for Pt. 30	1
21	Screwed collar	1	92	Reverse shaft collar	1	345	Set screws for Pt. 30	1
22	Second shaft bush R/H	1		Reverse Idler Shaft		354	Lock screws for Pts. 36 & 40	2
23	Screwed plug for bush Pt.22	1	53	Reverse idler shaft	1	363	Front bearing - GAMET	1
24	Second shaft gear (41T)	1	54	Retaining washer	1	901	Back bearing - GAMET	1
25	Second shaft gear (47T/20T)	1	55	Reverse idler gear (25T)	1	902	Reverse Shaft	2
26	Second shaft gear (42T)	1	91	Reverse shaft washer	1		Needle bearings for Pt. 47	2
27	Second shaft gear (23T/36T)	1		Driving Shaft		191	Gear retaining screw	1
28	Collar, spacing	1	003	Clutch driving shaft keys	2	212	Bearing retaining screws	3
29	Main Spindle		025	Driving shaft bush oil ring	1	225	Retaining washer pin	1
30	Spindle nose key	1	187	Needle bearing for Pt. 5	2	754	Shaft circlip	1
31	Spindle nose draw nut	1	188	Flanged bearing oilseal	1	866	Reverse shaft oilseal	1
32	Spindle bearing cover	1	224	Screwed plug retaining screw	1		Idler Shaft (Reverse)	
33	Front bearing location peg	1	227	Retaining screws for Pts. 5 & 12	4	183	Needle bearings for Pt. 55	2
34	Front bearing cover gasket	1	363	Retaining screws	2	204	Shaft retaining screws	2
35	Front bearing shield	1	520	Pulley retaining washer pin	1	212	Gear retaining screws	1
36	Spindle screwed collar	1	745	Expanding lever circlip	1	520	Retaining washer pin	1
37	Thrust collar	1	778	Fulcrum stud circlip	1			

SPECIFICATIONS OF STANDARD PARTS ARE GIVEN IN APPENDIX 1 AT THE END OF THIS SPARE PARTS SECTION

HEADSTOCK MAIN CASTINGS AND LEVER ASSEMBLIES

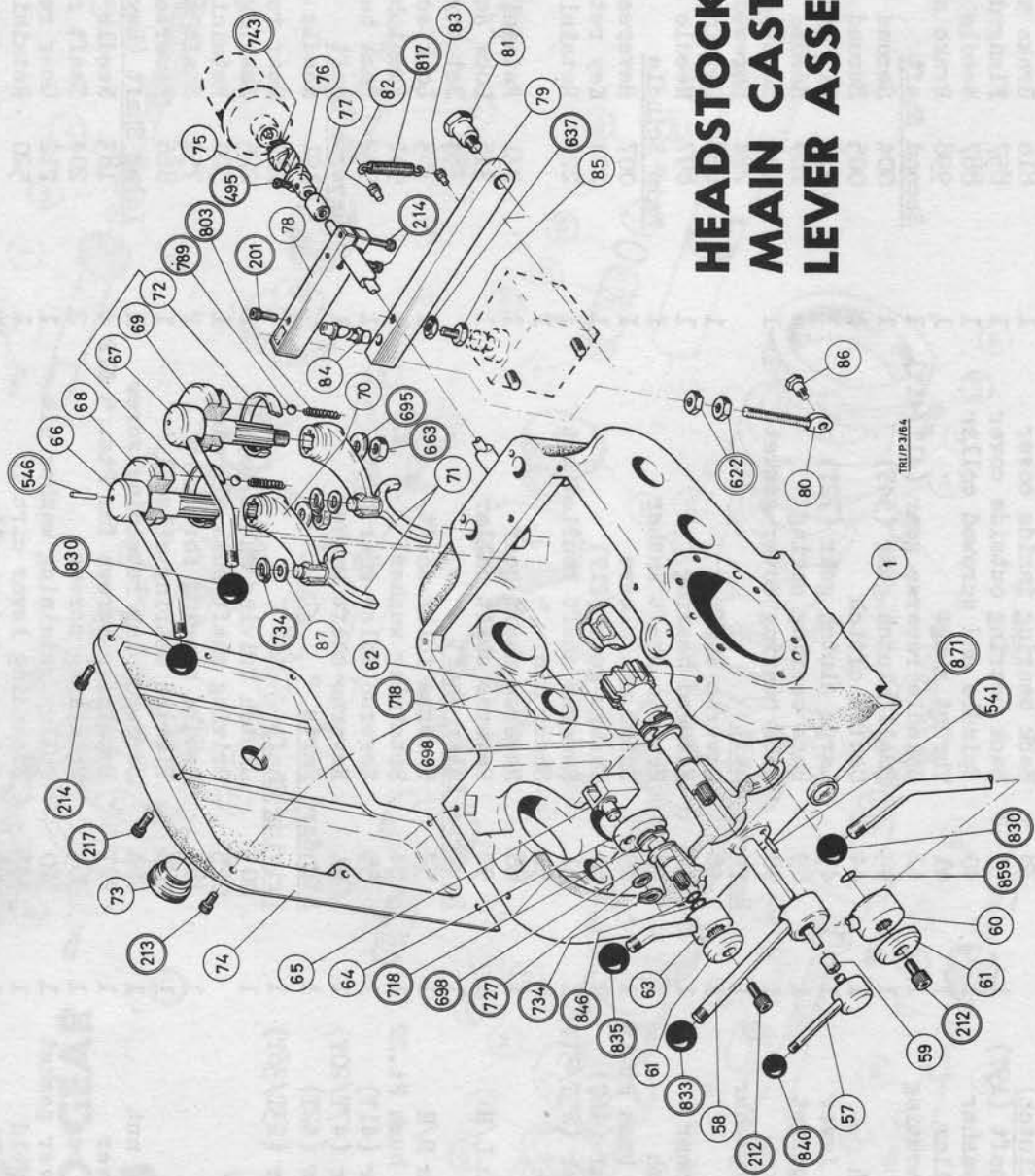

HEADSTOCK - Main Castings and Lever Assemblies

Ref. Dwg. TRL/P3/64

<u>Item No.</u>	<u>Description</u>	<u>No.off.</u>	<u>Item No.</u>	<u>Description</u>	<u>No.off.</u>
<u>Headstock Main Casting</u>					
1	Headstock main casting	1	83	Return spring stud - short	1
<u>Top Cover</u>					
74	Headstock top cover	1	84	Locking pawl	2
<u>Levers</u>					
57	Reverse lever assembly	1	85	Limit switch operating bolt	1
58	Operating lever assembly	1	86	Shoulder bolt for Pt. 80	1
59	Reverse switch lever bush	2	<u>Standard Parts</u>		
60	Spindle gear shifting lever	1	<u>Levers</u>		
61	Shifting lever collar	2	214	Headstock cover screws	3
62	Clutch shifting pinion	1	217	Headstock cover screws	2
63	Reverse gear shifting lever	1	213	Headstock cover screws	3
64	Reverse gear eccentric shaft	1	212	Retaining screws for Pts. 62 & 64	2
65	Gear shifting fork	1	541	Operating lever lock pin	1
66	Driving shaft gear shifter lever L/H	1	546	Gear shifting lever pins	2
67	Driving shaft gear shifter lever R/H	1	695	Gear shifting lever washer	2
68	Driving shaft gear selector L/H	1	698	Reverse shifting shaft washer	2
69	Driving shaft gear selector R/H	1	718	Reverse shifting shaft spring washer	2
70	Internal gear lever	2	734	Circlips for Pts. 65 & 71	2
71	Gear shifter fork9	2	846	Oil rings for Pt. 64	3
72	Selector sleeve	2	859	Oil rings for Pt. 62	2
73	Filler plug	1	663	Gear shifter lock nuts	1
87	Shifting fork washer	3	789	Gear selector location balls	2
<u>Limit and Reverse Switch Linkage</u>					
75	Reverse switch coupling - female	1	803	Gear selector compression spring	2
76	Reverse switch coupling - male	1	840	Reverse switch lever knob	1
77	Coupling spacer	1	833	Starting lever knob	1
78	Brake operating lever	1	835	Reverse shaft lever knob	1
79	Switch operating lever	1	830	Gear shifter lever knob	3
80	Expanding lever link	1	<u>Limit and Reverse Switches</u>		
81	Shoulder bolt for lever No. 79	1	201	Locking pawl screws	2
82	Return spring stud - long	1	214	Clamping screws for Pt. 78	2
			495	Reverse switch coupling screw	1
			622	Lock nuts for Pt. 80	2
			743	Switch coupling circlip	1
			817	Return spring	1

SPECIFICATIONS OF STANDARD PARTS ARE GIVEN IN APPENDIX I AT THE END OF THIS SPARE PARTS SECTION

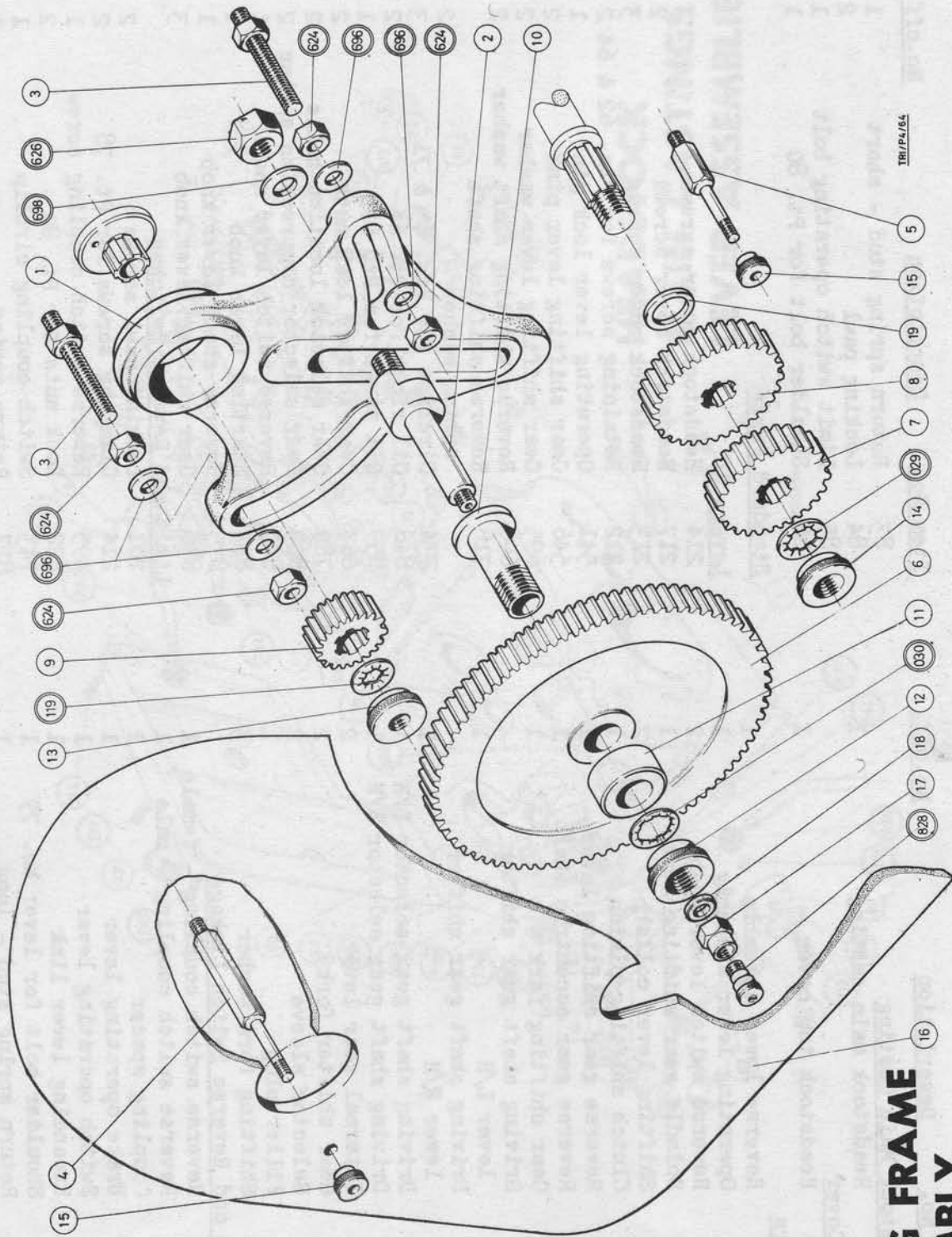

TR/P4/54

**SWING FRAME
ASSEMBLY**

GEARBOX ASSEMBLY GEARS AND SHAFTS

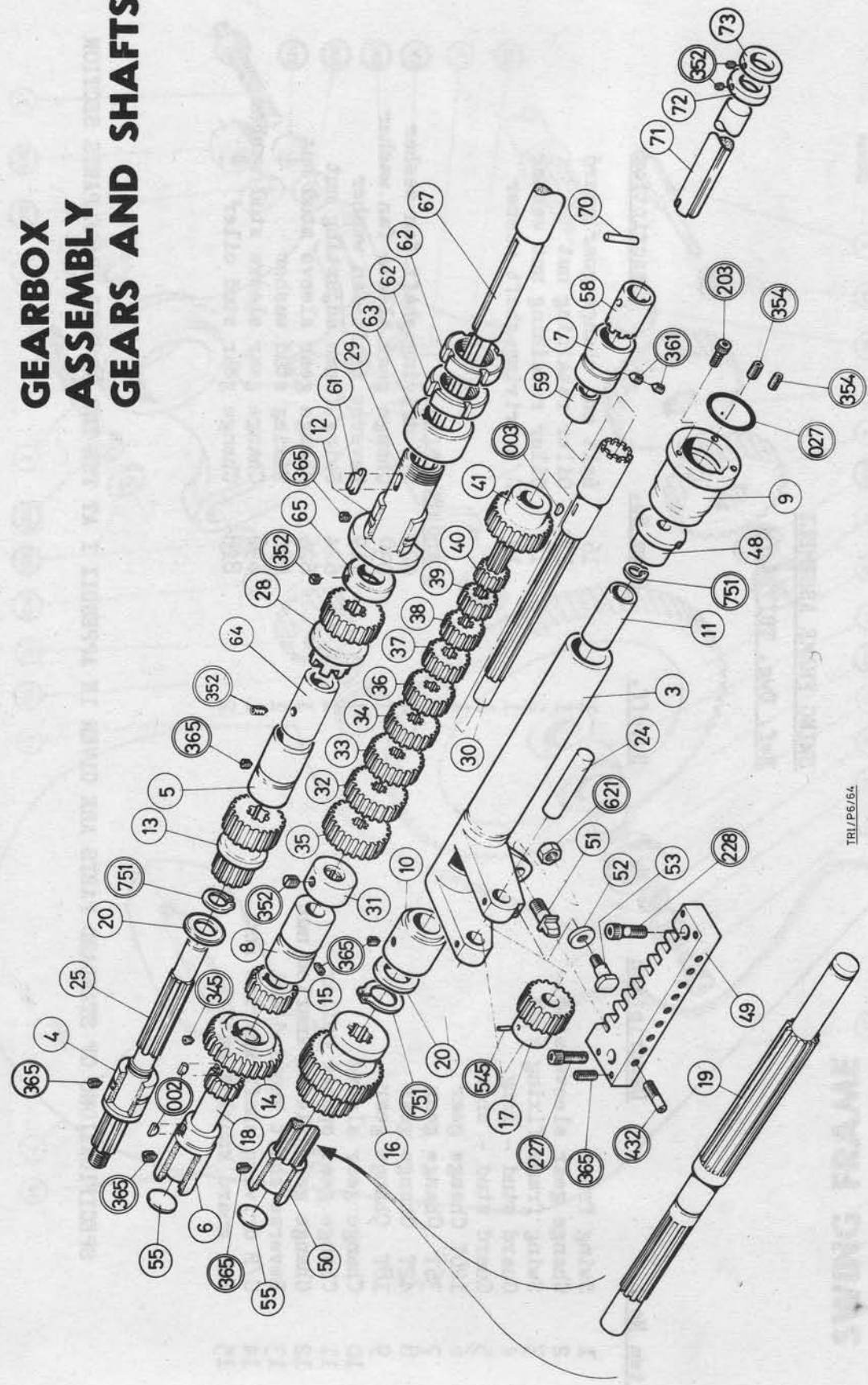

TR1/P6/64

SWING FRAME
ASSEMBLY

GEARBOX ASSEMBLY

Ref. Dwg. TRI/P6/64

<u>Item No.</u>	<u>Description</u>	<u>No.off.</u>	<u>Item No.</u>	<u>Description</u>	<u>No.off.</u>
<u>Gears and Shafts</u>					
3	Tumbler bearing	1	48	Tumbler bearing plug	1
4	Driving shaft bush - L/H	1	49	Tumbler locating strip	1
5	Driving shaft bush - R/H	1	50	Tumbler shaft bush - L/H	1
6	Inter shaft bush	1	51	Tumbler locating pin	1
7	Cone shaft bush - R/H	1	52	Tumbler roller	1
8	Cone shaft bush - L/H	1	53	Tumbler roller pin	1
9	Tumbler bearing bush-R/H	1	55	Core plug for Pts. 6 & 50	2
10	Tumbler shaft bush - Centre	1	58	Slipping clutch collar	1
11	Tumbler shaft bush - R/H	1	59	Slipping clutch shaft bush	1
12	Leadscrew bush	1	61	Key for leadscrew	1
13	Driving shaft gear 16T/24T	1	62	Leadscrew locknut	2
14	Intershaft gear 32T	1	63	Leadscrew thrust collar	1
15	Intershaft gear 24T	1	64	Leadscrew gear spacer bush	1
16	Tumbler shaft gear 24T/42T	1	65	Leadscrew screwed collar	1
17	Tumbler gear 27T	1	67	Leadscrew	1
18	Intermediate shaft 14T	1	70	Slipping clutch pin	1
19	Tumbler shaft 14T	1	71	Spline shaft	1
20	Driving shaft washer	1	72	Spline shaft collar (inside)	1
24	Tumbler gear shaft	2	73	Spline shaft collar (outside)	1
25	Driving shaft	1	<u>Standard Parts</u>		
28	Leadscrew gear 24T	1	002	Intermediate shaft key	2
29	Leadscrew thrust sleeve	1	003	Cone shaft key	1
30	Cone shaft	1	203	Securing screw for Pt. 9	3
31	Cone shaft screwed collar	1	227	L/H retaining screw for Pt. 49	1
32	Cone shaft gear 28T	1	228	R/H retaining screw for Pt. 49	1
33	Cone shaft gear 26T	1	352	Lock screw for Pts. 31, 64, 65, 72 & 73	4
34	Cone shaft gear 24T	1	354	Locating screw for Pt. 48	2
35	Cone shaft gear 23T	1	361	Lock screw for Pt. 7	2
36	Cone shaft gear 22T	1	365	Bush locking screw	11
37	Cone shaft gear 20T	1	432	Location pin stop screw	9
38	Cone shaft gear 19T	1	545	Securing pin for Pt. 17	1
39	Cone shaft gear 18T	1	621	Location pin retaining nut	1
40	Cone shaft gear 16T	1	627	Oil ring for Pt. 9	1
41	Cone shaft pinion 24T	1	751	Gear retention clip	3

SPECIFICATIONS OF STANDARD PARTS ARE GIVEN IN APPENDIX I AT THE END OF THIS SPARE PARTS SECTION

STANDARD GEARBOX — covers and levers

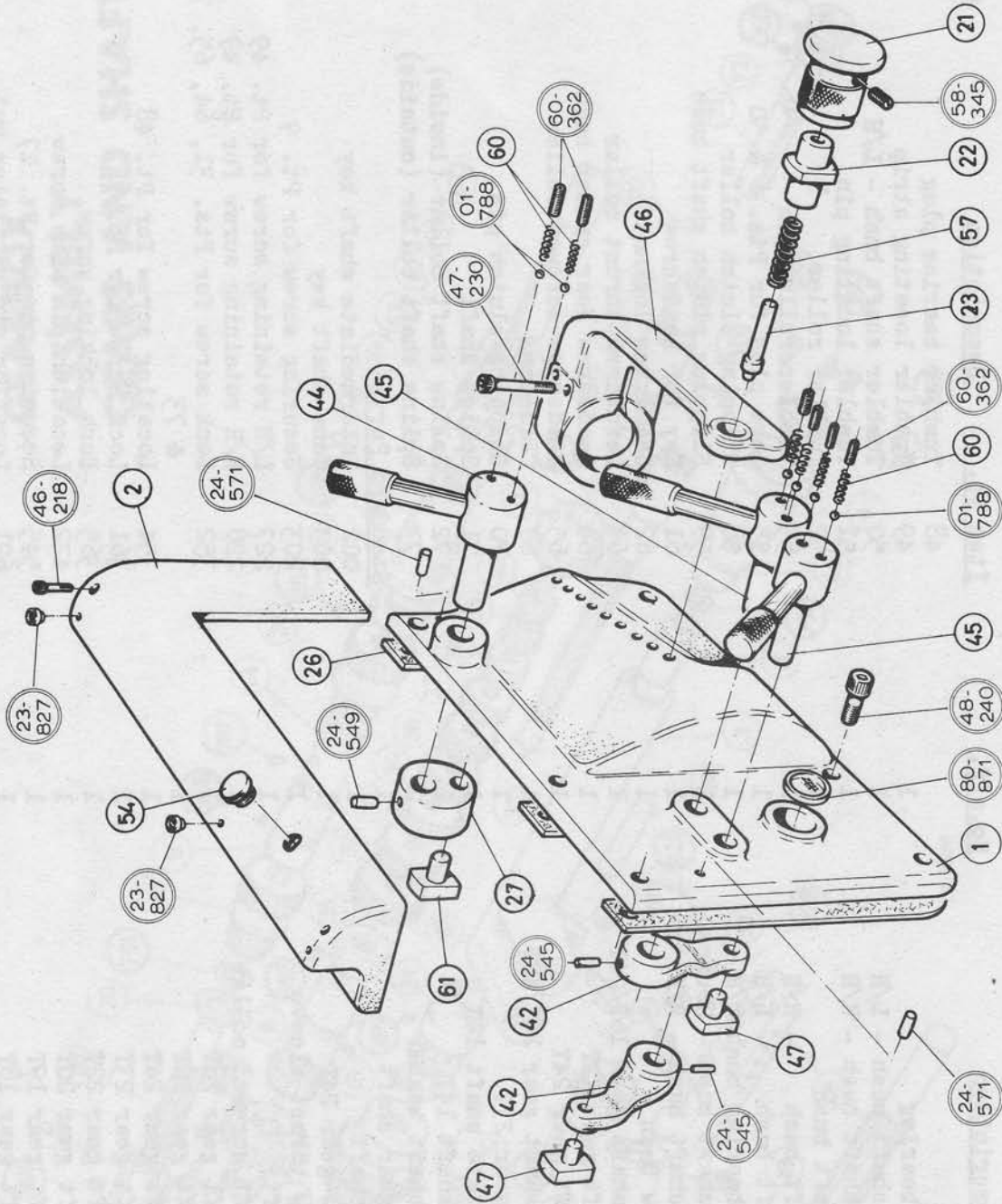

TRI/P5/64

GEARBOX (STANDARD & DOMINION) COVERS AND LEVERSREFERENCE DRG. TRI/P5/64.

<u>Item No.</u>	<u>Description</u>	<u>No. Off.</u>	<u>Item No.</u>	<u>Description</u>	<u>No. Off.</u>
1	Gearbox Front Cover	1			
2	Gearbox Top Cover	1			
21	Tumbler Handle	1			
22	Tumbler Handle Socket	1			
23	Tumbler Handle Plunger	1			
26	Gearbox Cover Gasket	1			
27	Eccentric Gearshifting Lever	1			
42	Gear Shifting Lever	2			
43/44	Leadscrew Gear Shift Shaft & Lever	1			
43/45	Gear Shift Shaft & Lever	2			
46	Tumbler Arm	1			
47	Gear Shift Pads	2			
54	Filler Plug	1			
57	Tumbler Handle Spring	1			
60	Gear Lever Spring	6			
61	Leadscrew Gear Shift Pad	1			
			<u>Standard Parts</u>		
			46-218	Top Cover Securing Screw	2
			47-230	Tumbler Arm Clamping Screw	1
			48-240	Front Cover Securing Screw	6
			60-362	Lever Spring Tension Screw	6
			58-345	Tumbler Handle Locking Screw	1
			24-545	Securing Pin for Pt. 42	2
			24-549	Securing Pin for Pt. 27	1
			24-571	Front Cover Dowel	2
			01-788	Lever Locating Balls	6
			23-827	Oiler	2
			80-871	Oil Sight	1

SPECIFICATIONS OF STANDARD PARTS ARE GIVEN IN APPENDIX 1 AT THE END OF THIS SPARE PARTS SECTION

APRON ASSEMBLY

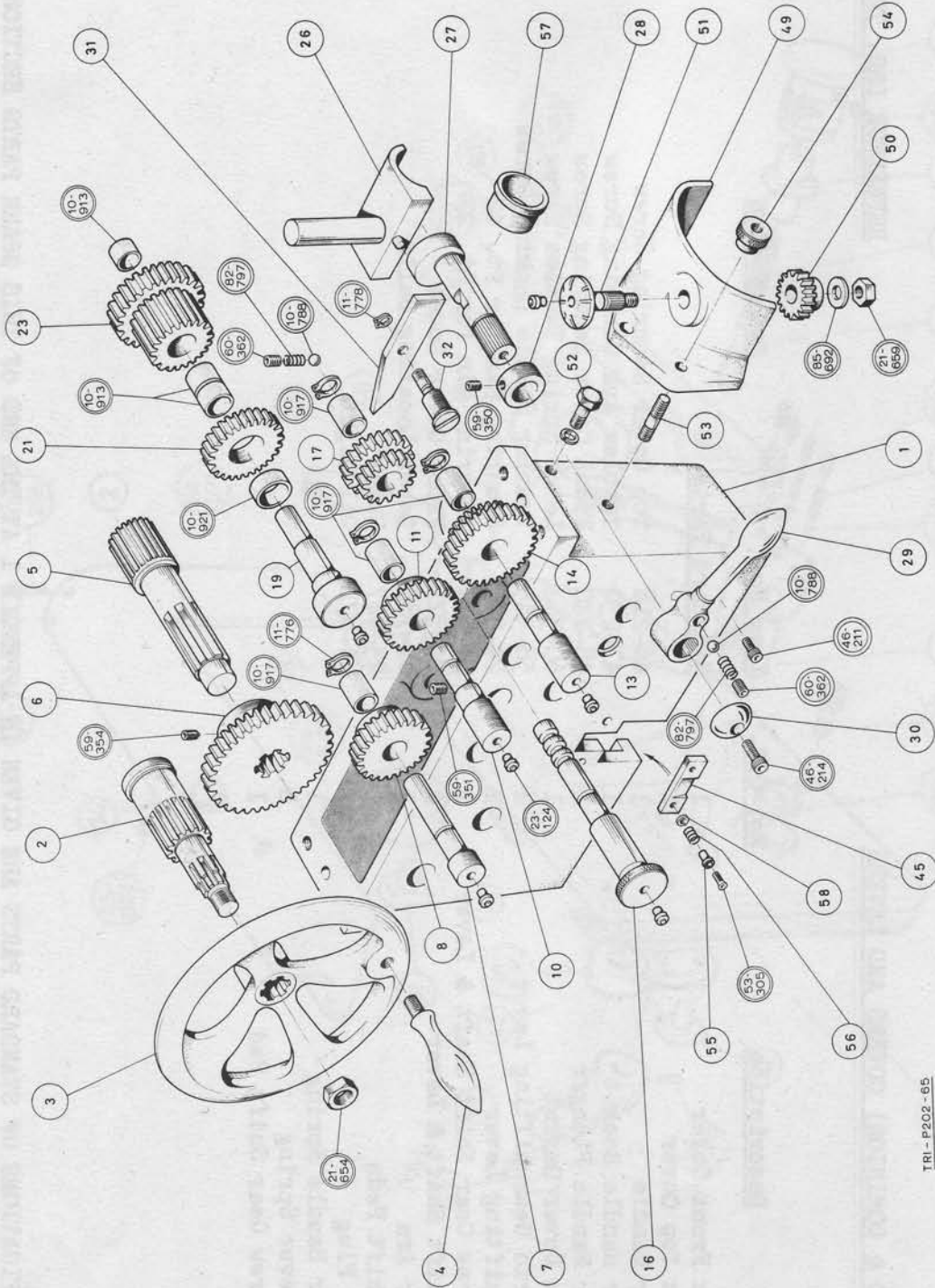

TRI-P202-65

APRON ASSEMBLY

REFERENCE DRG. TRI-P202-65

<u>Item No.</u>	<u>Description</u>	<u>No. Off</u>	<u>Item No.</u>	<u>Description</u>	<u>No. Off</u>	<u>Item No.</u>	<u>Description</u>	<u>No. Off.</u>
1	Apron, main casting	1	28	Camshaft collar	1	<u>STANDARD PARTS</u>		
2	Handwheel racking shaft	1	29	Leadscrew nut handle	1	23-124	Oiler nipples	5
3	Handwheel	1	30	Domed washer for Pt. 29	1	46-211	Stop screws	2
4	Handwheel handle	1	31	Safety strip	1	46-214	Handle retaining screw	1
5	Rack shaft pinion	1	32	Safety strip pivot shaft	1	53-305	Latch retaining screw	2
6	Sliding gear - 44T	1	45	Latch bar	1	59-350	Retaining screw, Pt. 28	1
7	Gear shaft	1	49	Dial indicator guard	1	59-351	Setscrew, Pts. 7, 10, 13 & 19	4
8	Gear, 27T	1	50	Dial indicator gear	1	59-354	Gear securing screw	1
10	Gear shaft	1	51	Dial indicator	1	60-362	Detent retaining screw	2
11	Gear, 27T	1	52	Stud, indicator guard	1	21-654	Handwheel nut	1
13	Gear shaft	1	53	Stud, guard retaining	1	21-659	Retaining nut, Pt. 50	1
14	Double gear - 18/34T	1	54	Locking nut for guard	1	85-692	Washer for Pt. 51	1
16	Shaft gear selector	1	55	Latch bar bush	2	11-776	Circlip, Pts. 8, 11, 14 & 17	4
17	Double gear - 18/23T	1	56	Latch bar spring	2	11-778	Circlip for Pt. 32	1
19	Gear shaft	1	57	Leadscrew bush	1	01-788	Ball detent, Pts. 16 & 29	2
21	Gear, 27T	1	58	Latch damper washer	2	82-797	Detent spring	2
23	Gear - 22 and 32T	1				10-913	Gear bush, Pt. 23	3
26	Leadscrew halfnut	1				10-917	Gear bush, Pts. 8, 11, 14 & 17	4
27	Leadscrew nut cam	1				10-921	Gear bush, Pt. 21	1

SPECIFICATIONS OF STANDARD PARTS ARE GIVEN IN APPENDIX 1 AT THE END OF THIS SECTION

APRON ASSEMBLY

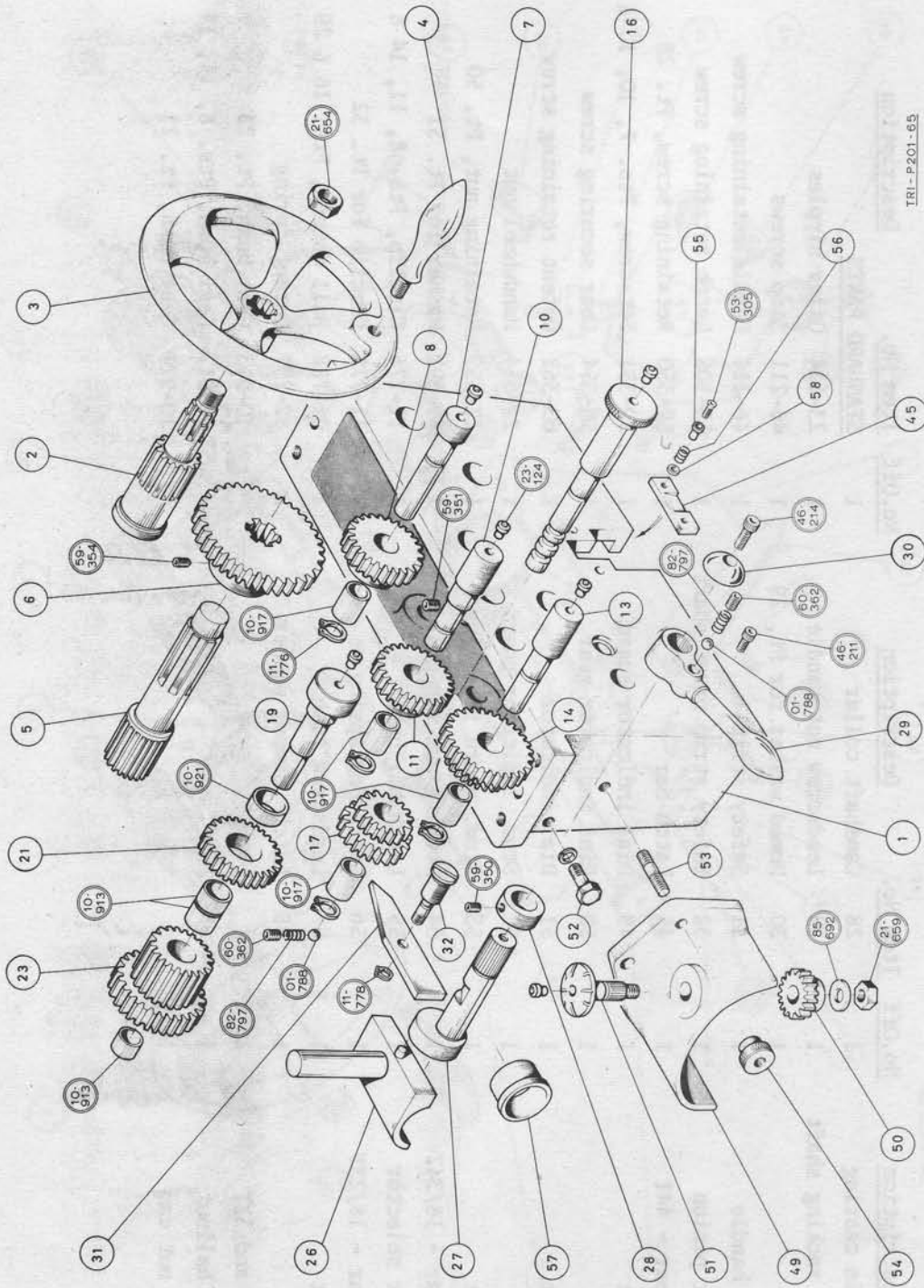

TRI-P201-65

APRON ASSEMBLYGap Bed Lathes

REFERENCE DRG. TRI-P201-65

<u>Item No.</u>	<u>Description</u>	<u>No. Off</u>	<u>Item No.</u>	<u>Description</u>	<u>No. Off</u>	<u>Item No.</u>	<u>Description</u>	<u>No. Off.</u>
1	Apron, main casting	1	28	Camshaft collar	1	<u>STANDARD PARTS</u>		
2	Handwheel racking shaft	1	29	Leadscrew nut handle	1	23-124	Oiler nipples	5
3	Handwheel	1	30	Domed washer for Pt. 29	1	46-211	Stop screws	2
4	Handwheel handle	1	31	Safety strip	1	46-214	Handle retaining screw	1
5	Rack shaft pinion	1	32	Safety strip pivot shaft	1	53-305	Latch retaining screw	2
6	Sliding gear - 44T	1	45	Latch bar	1	59-350	Retaining screw, Pt. 28	1
7	Gear shaft	1	49	Dial indicator guard	1	59-351	Setscrew, Pts. 7, 10, 13 & 19	4
8	Gear, 27T	1	50	Dial indicator gear	1	59-354	Gear securing screw	1
10	Gear shaft	1	51	Dial indicator	1	60-362	Detent retaining screw	2
11	Gear, 27T	1	52	Stud, indicator guard	1	21-654	Handwheel nut	1
13	Gear shaft	1	53	Stud, guard retaining	1	21-659	Retaining nut, Pt. 50	1
14	Double gear - 18/34T	1	54	Locking nut for guard	1	85-692	Washer for Pt. 51	1
16	Shaft gear selector	1	55	Latch bar bush	2	11-776	Circlip, Pts. 8, 11, 14 & 17	4
17	Double gear - 18/23T	1	56	Latch bar spring	2	11-778	Circlip for Pt. 32	1
19	Gear shaft	1	57	Leadscrew bush	1	01-788	Ball detent, Pts. 16 & 29	2
21	Gear, 27T	1	58	Latch damper washer	2	82-797	Detent spring	2
23	Gear - 22 and 32T	1				10-913	Gear bush, Pt. 23	3
26	Leadscrew halfnut	1				10-917	Gear bush, Pts. 8, 11, 14 & 17	4
27	Leadscrew nut cam	1				10-921	Gear bush, Pt. 21	1

SPECIFICATIONS OF STANDARD PARTS ARE GIVEN IN APPENDIX 1 AT THE END OF THIS SECTION

APRON

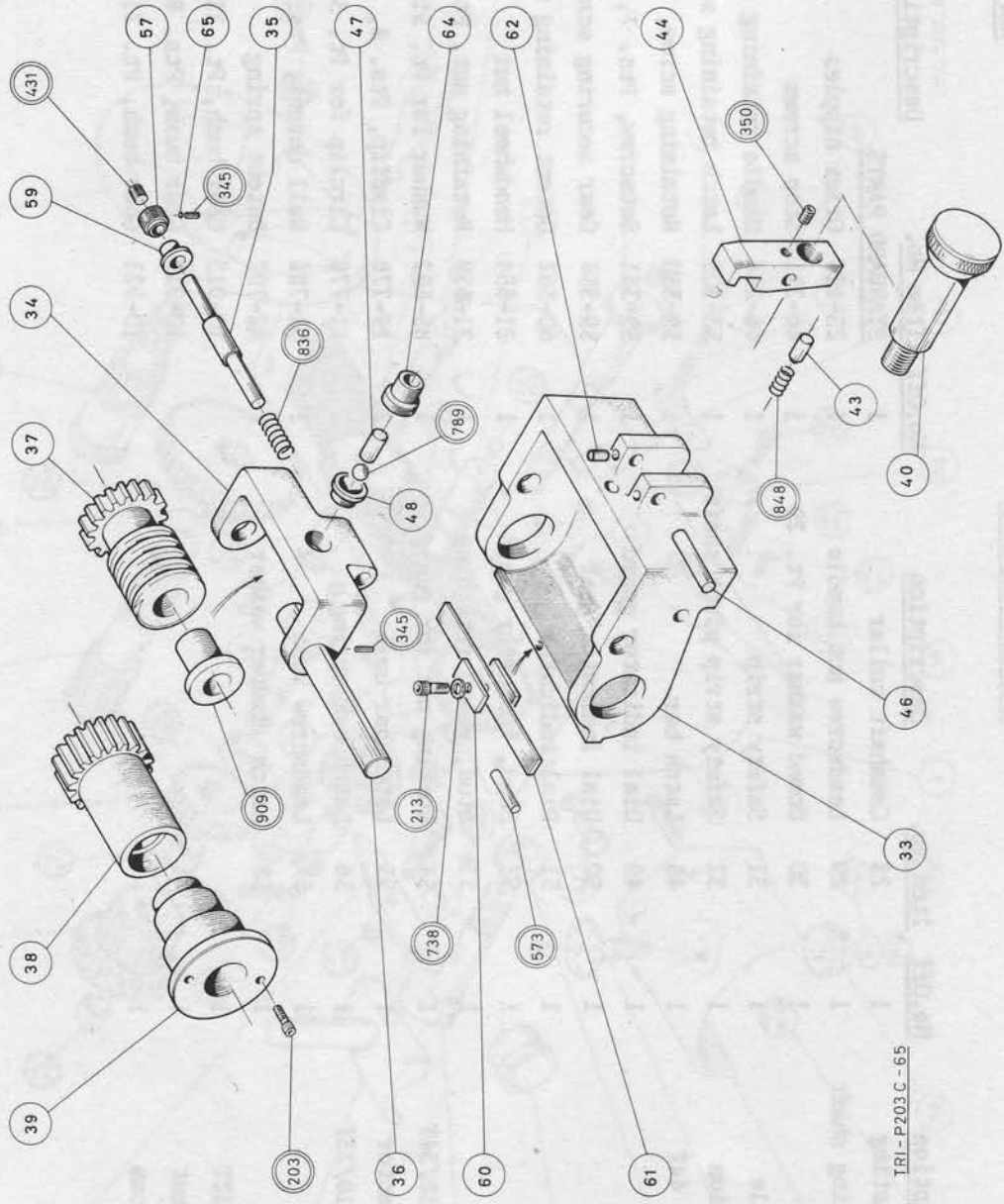

TRI-P203 C - 65

SADDLE AND SLIDES STRAIGHT BED LATHES

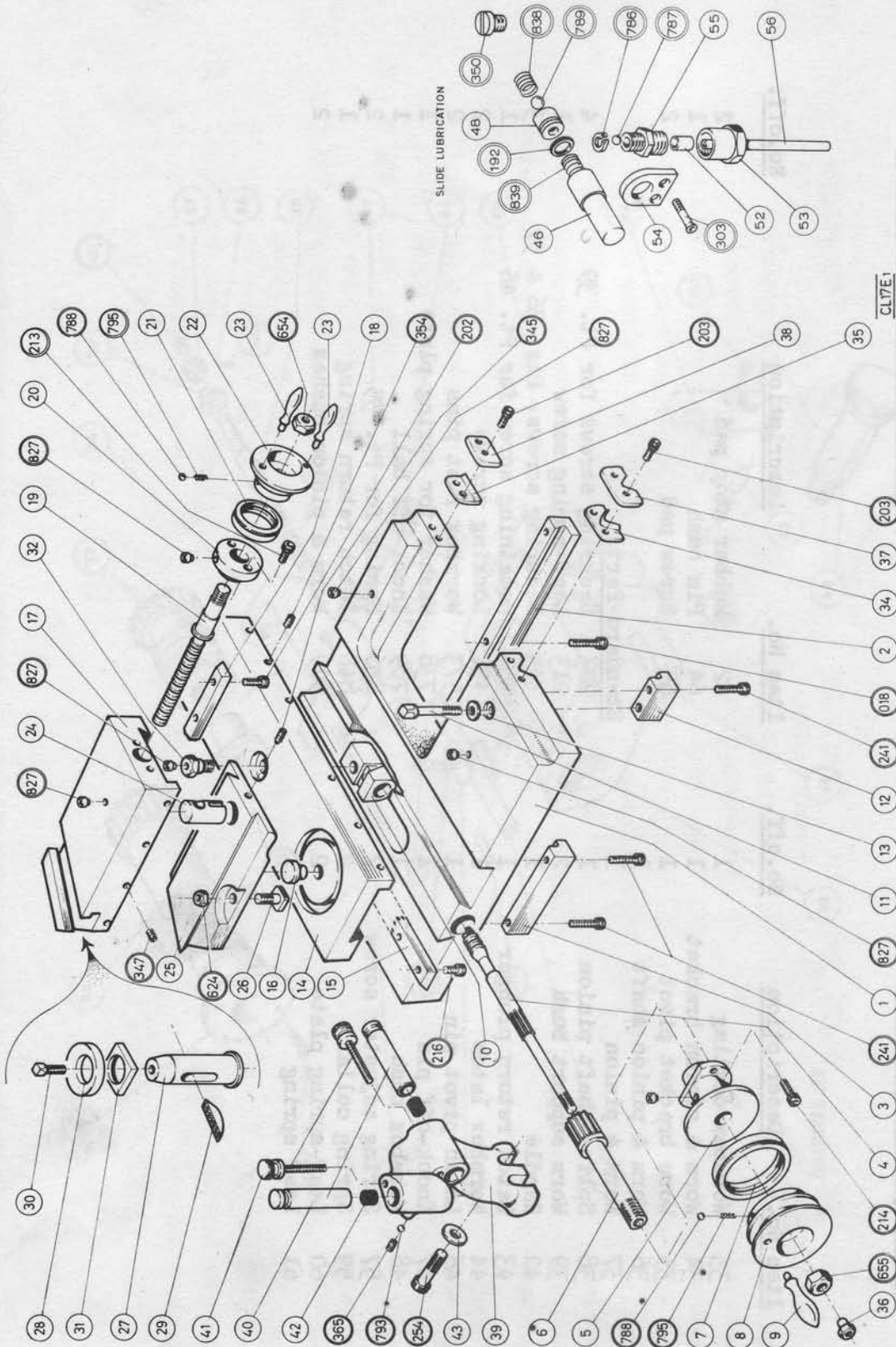

SADDLE AND SLIDES ASSEMBLY - Straight Bed Lathes

Ref. Dwg. CL17E1

Item No.	Description	No. off.	Item No.	Description	No. off.
<u>Saddle</u>					
1	Saddle	1	42	Finger insert	2
2	Back strip	1	43	Clamping screw washer	2
3	Front strip	1	<u>Slide Lubrication</u>		
11	Locking bolt	1	46	Lubricating plunger	1
12	Locking strip	1	47	Compression spring	1
13	Locking bolt washers	1	48	Valve bush	1
34	Vee bedway wiper)		49	Compression spring	1
35	Flat bedway wiper)	Set of 4	50	Oil filler plug	1
37	Vee wiper shield)		51	Compression spring	1
38	Flat wiper shield)	Set of 4	52	Union sleeve	1
			53	Union nut	1
			54	Pin	1
<u>Cross Slide</u>			55	Connector	1
14	Main casting	1	56	Standpipe	1
15	Gib	2	<u>Standard Parts</u>		
16	Pivot for swivel slide	1	<u>Saddle</u>		
4	Screw	1	018	Strip securing screw	7
5	Keep	1	203	Bedway wiper securing screw	8
6	Screw pinion	1	241	Securing screws for Pts. 3 & 12	4
7	Index ring	1	<u>Cross Slide</u>		
8	Handwheel	1	214	Keep retaining screw	2
9	Handwheel handle	1	216	Gib securing screw	6
10	Screw nut	1	354	Gib adjusting screw	4
32	Nut securing bolt	1	655	Pinion locking nut	1
36	Screw retaining nut	1	788	Index ring pressure ball	3
<u>Swivel Slide</u>			795	Index ring pressure spring	3
25	Swivel slide	1	<u>Top Slide</u>		
26	Clamping bolt	2	202	Gib securing screw	4
<u>Top Slide</u>			213	Keep securing screw	2
17	Main casting	1	345	Nut securing screw	1
18	Gib	1	347	Gib adjusting screw	4
19	Screw	1	654	Screw retaining nut	1
20	Keep	1	788	Index ring pressure ball	3
21	Index ring	1	795	Index ring pressure spring	3
22	Handwheel	1	<u>Steady, Swivel Slide Etc.</u>		
23	Handwheel handle	2	365	Steady finger clamping screw	2
24	Screw nut	1	624	Swivel slide clamping nut	2
<u>Toolholder</u>			256	Steady clamping screw	2
27	Tool post	1	793	Steady finger clamping ball	2
28	Collar	1	827	Oiler	7
29	Swivel piece	1	<u>Slide Lubrication</u>		
30	Tool screw	1	192	Valve bush 'O' ring	1
31	Clamp plate	1	350	Plunger screw	1
<u>Travelling Steady</u>			786	Connector ball	1
39	Main casting	1	787	Lubricating plunger ball	1
40	Finger	2	789	Valve bush ball	1
41	Finger adjusting screw	2			

SPECIFICATIONS OF STANDARD PARTS ARE GIVEN IN APPENDIX I AT THE END OF THIS SPARE PARTS SECTION

SADDLE AND SLIDES ASSEMBLY - Gap Bed Lathes

Ref. Dwg. CL17E2

Item No.	Description	No. off.	Item No.	Description	No. off.	Item No.	Description	No. off.
1	Saddle	1	20	Keep	1			
2	Back strip	1	21	Index ring	1			
3	Front strip	1	22	Handwheel	1			
11	Locking bolt	1	23	Handwheel handle	1			
12	Locking strip	1	25	Screw nut	1			
13	Locking bolt washer	1						
34	Vee bedway wiper)	set of 4	Toolpost		1			
35	Flat bedway wiper)	set of 4	27	Toolpost	1			
37	Vee wiper shield)		28	Collar	1			
38	Flat wiper shield)		29	Swivel piece	1			
			30	Toolpost screw	1			
			31	Clamp plate	1			
				Travelling Steady				
14	Main casting	1	39	Main casting	1			
15	Gib	2	41	Finger adjusting screw	2			
16	Pivot for swivel slide	1	40	Finger	1			
4	Screw	1	42	Finger insert	1			
6	Screw pinion	1	43	Clamping bolt	1			
5	Keep	1		Slide Lubrication				
7	Index ring	1	46	Lubricating plunger	1			
8	Handwheel	1	48	Valve bush	1			
9	Handwheel handle	1	52	Union sleeve	1			
10	Screw nut	1	53	Union nut	1			
32	Nut securing bolt	1	54	Plunger retaining plate	1			
36	Screw retaining nut	1	55	Connector	1			
	Swivel Slide		56	Standpipe	1			
26	Swivel slide	1		Standard Parts				
27	Clamping bolt	1		Saddle				
	op Slide		261	Saddle strip securing screw	6			
17	Main casting	1	203	Bedway wiper securing screw	8			
18	Gib	1						
19	Screw	1						

SPECIFICATIONS OF STANDARD PARTS ARE GIVEN IN APPENDIX I AT THE END OF THIS SPARE PARTS SECTION

SADDLE AND SLIDES

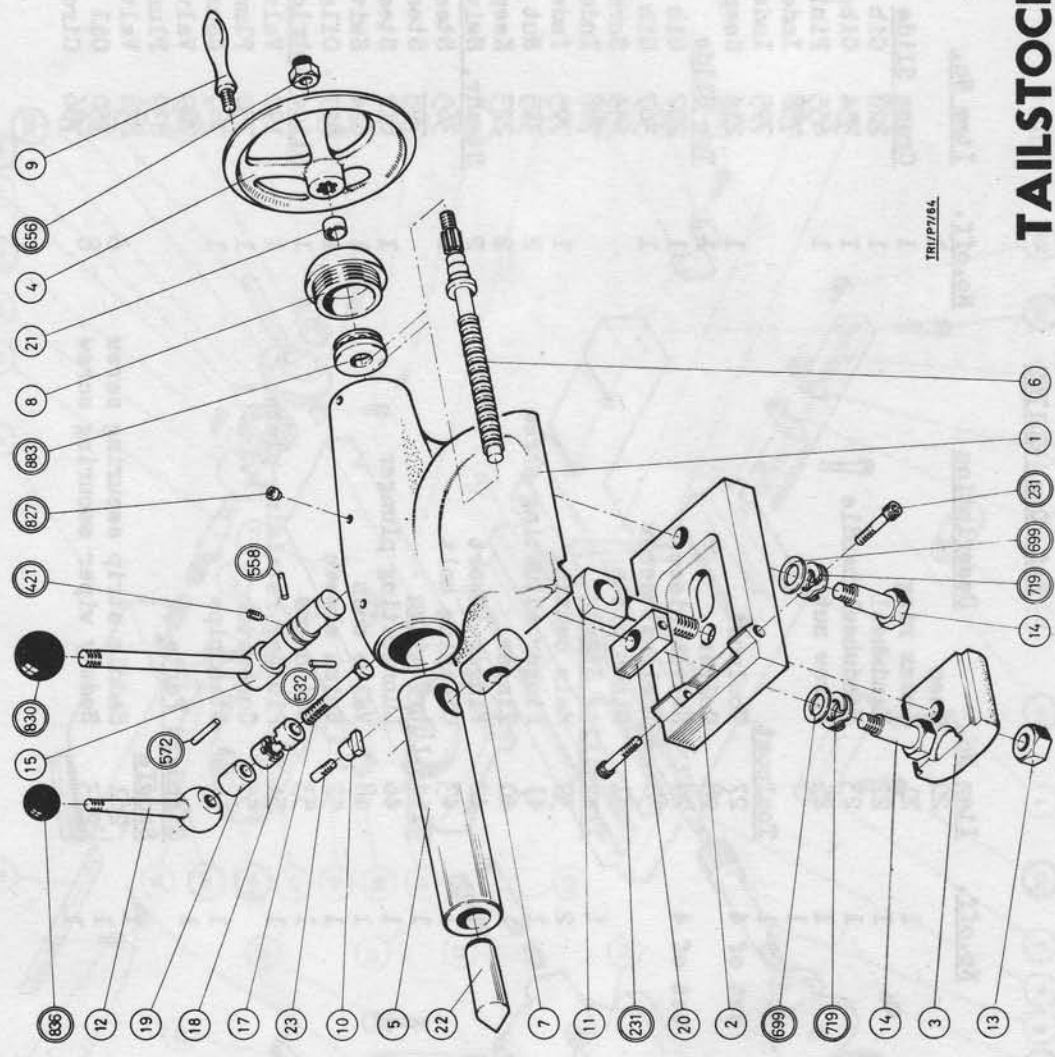

TR1/P7/84

TAILSTOCK ASSEMBLY

- 1 6
- 2 1
- 3 231
- 4 699
- 5 719
- 6 14
- 7 7
- 8 8
- 9 827
- 10 863
- 11 21
- 12 4
- 13 656
- 14 9
- 15 830
- 16 532
- 17 558
- 18 372
- 19 12
- 20 2
- 21 231
- 22 20
- 23 2
- 24 699
- 25 719
- 26 14
- 27 3
- 28 13
- 29 1
- 30 231

TAILSTOCK ASSEMBLY

Ref. Dwg. TRI/P7/64

<u>Item No.</u>	<u>Description</u>	<u>No.off.</u>	<u>Item No.</u>	<u>Description</u>	<u>No.off.</u>
1	Tailstock main casting	1	18	Barrel clamping bush	2
2	Tailstock base	1	19	Barrel clamping spacer	1
3	Clamp plate	1	20	Set over bar	1
4	Handwheel	1	21	Keep bush	1
5	Barrel	1	<u>Standard Parts</u>		
6	Barrel screw	1	558	Clamping cam pin	1
7	Barrel nut	1	572	Barrel locking lever stop pin	1
8	Screw keep	1	532	Barrel clamping spacer pin	1
9	Handwheel handle	1	421	Clamping cam locking screw	1
10	Barrel key	1	231	Set over bar adjusting screw	2
11	Eyebolt - clamping	1	699	Washer for Pt. 14	2
12	Barrel clamping lever	1	719	Spring washer for Pt. 14	2
13	Clamping nut	1	656	Handwheel retaining nut	1
14	Base retaining bolt	2	883	Thrust bearing	1
15	Clamping cam	1	827	Oiler	3
16	Clamping handle stem	1	836	Barrel clamping lever knob	1
17	Barrel clamping bolt	1	830	Clamping handle knob	1

SPECIFICATIONS OF STANDARD PARTS ARE GIVEN IN APPENDIX I AT THE END OF THIS SPARE PARTS SECTION

TRI/P8/64

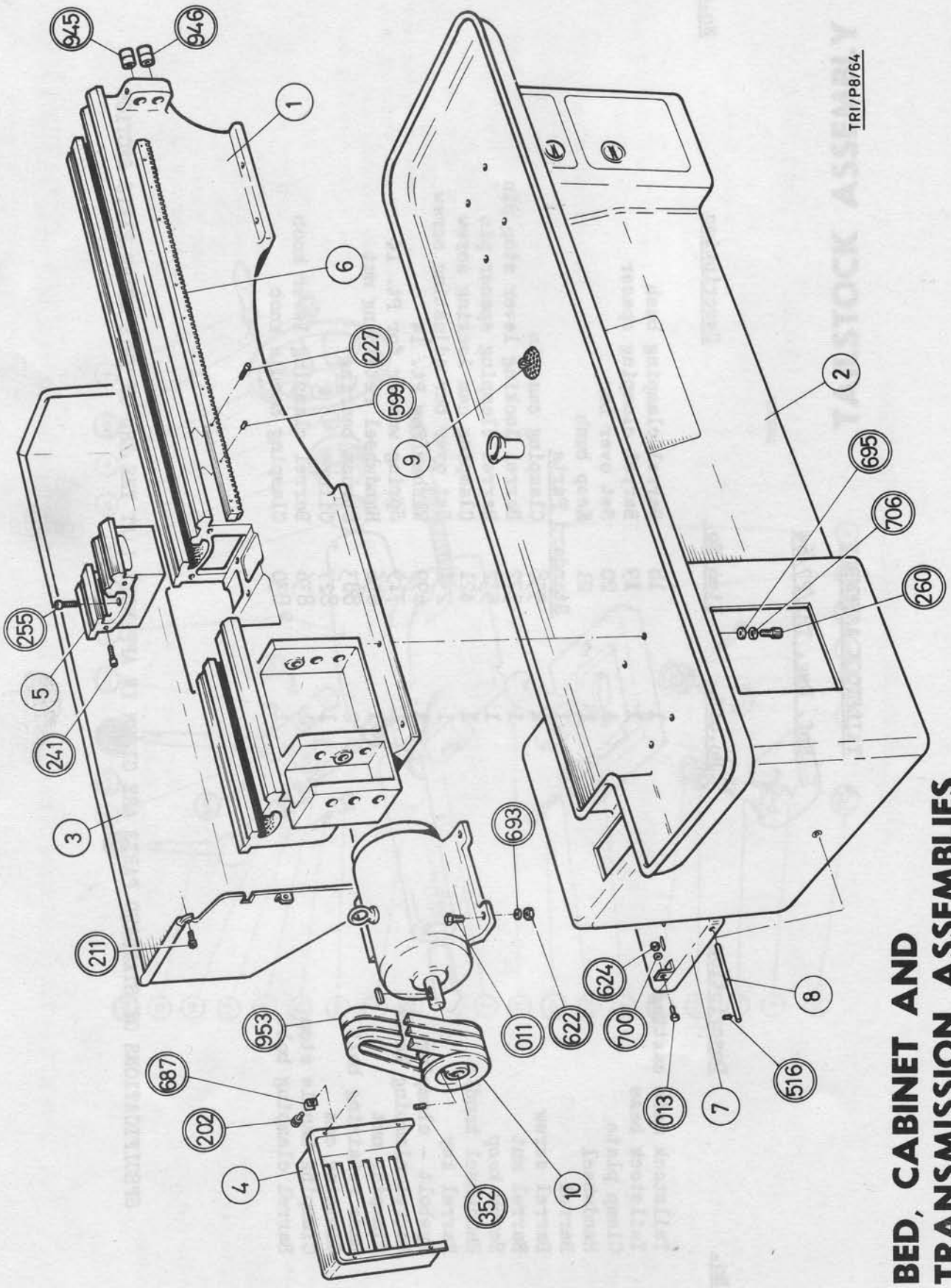

BED, CABINET AND TRANSMISSION ASSEMBLIES

BED, CABINET AND TRANSMISSION ASSEMBLIES

Ref. DWG. TRI/P8/64

<u>Item No.</u>	<u>Description</u>	<u>No.off.</u>	<u>Item No.</u>	<u>Description</u>	<u>No.off.</u>
1	Bed	1	202	Securing screw for Pt. 4	7
2	Cabinet	1	516	Pivot rod clamping screw	1
3	Splash guard	1	352	Motor pulley securing screw	1
4	Motor compartment cover	1	013	Motor platform securing bolt	1
5	Gap piece	1	011	Motor securing bolt	4
6	Rack	1	695	Bed securing washer	8
7	Motor platform	1	693	Motor securing washer	4
8	Motor plate pivot rod	1	599	Rack dowels	5
9	Coolant filter	1	624	Nut for Pt. 13	1
10	Motor pulley	1	622	Nut for Pt. 11	4
	<u>Standard Parts</u>		687	Nut for Pt. 4	7
260	Bed securing screw	8	700	Motor platform securing washer	1
255	Verticle securing screw for gap piece	2	706	Spring washer for Pt. 260	8
241	Horizontal securing screw for gap piece	2	945	Leadscrew bush	2
227	Rack securing screw	6	946	Feedshaft bush	2
211	Splash guard securing screw	3	953	Vee driving belts	3

SPECIFICATIONS OF STANDARD PARTS ARE GIVEN IN APPENDIX I AT THE END OF THIS SPARE PARTS SECTION

STEADY REST

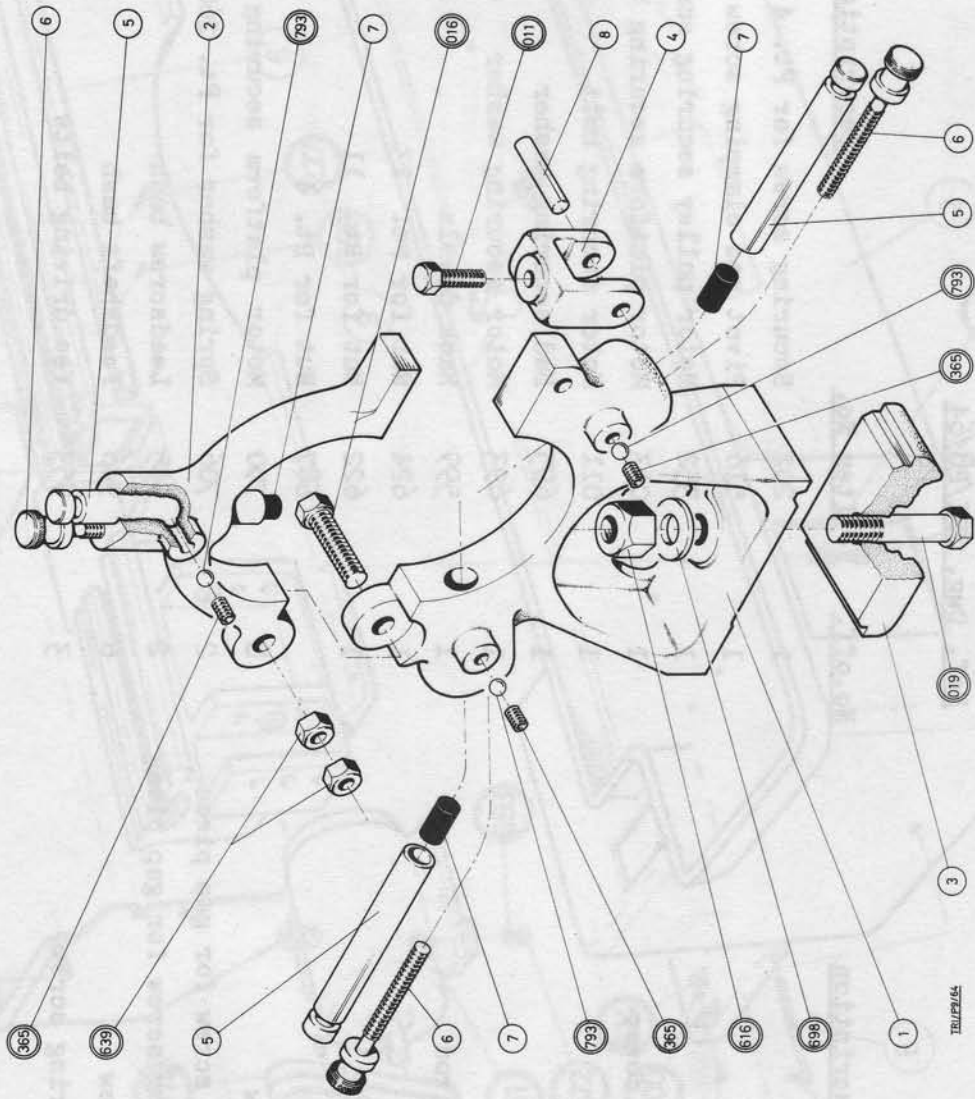

TRU/PR/44

BED, CABINET AND TRANSMISSION ASSEMBLIES

STEADY REST

Ref. Dwg. TRI/P9/64

<u>Item No.</u>	<u>Description</u>	<u>No.off.</u>	<u>Item No.</u>	<u>Description</u>	<u>No.off.</u>
1	Steady main casting	1	011	Steady clamp bolt	1
2	Steady top casting	1	016	Pivot bolt	1
3	Clamp plate	1	019	Clamp plate bolt	1
4	Steady clamp fork	1	365	Steady finger guide screw	3
5	Steady finger	3	616	Steady clamp nut	1
6	Steady screw	3	639	Pivot bolt lock nut	2
7	Steady finger insert	3	698	Clamp plate bolt washer	1
8	Loop pin	1	793	Steady finger guide ball	3

SPECIFICATIONS OF STANDARD PARTS ARE GIVEN IN APPENDIX I AT THE END OF THIS SPARE PARTS SECTION

STEADY REST

TELESCOPIC TAPER ATTACHMENT

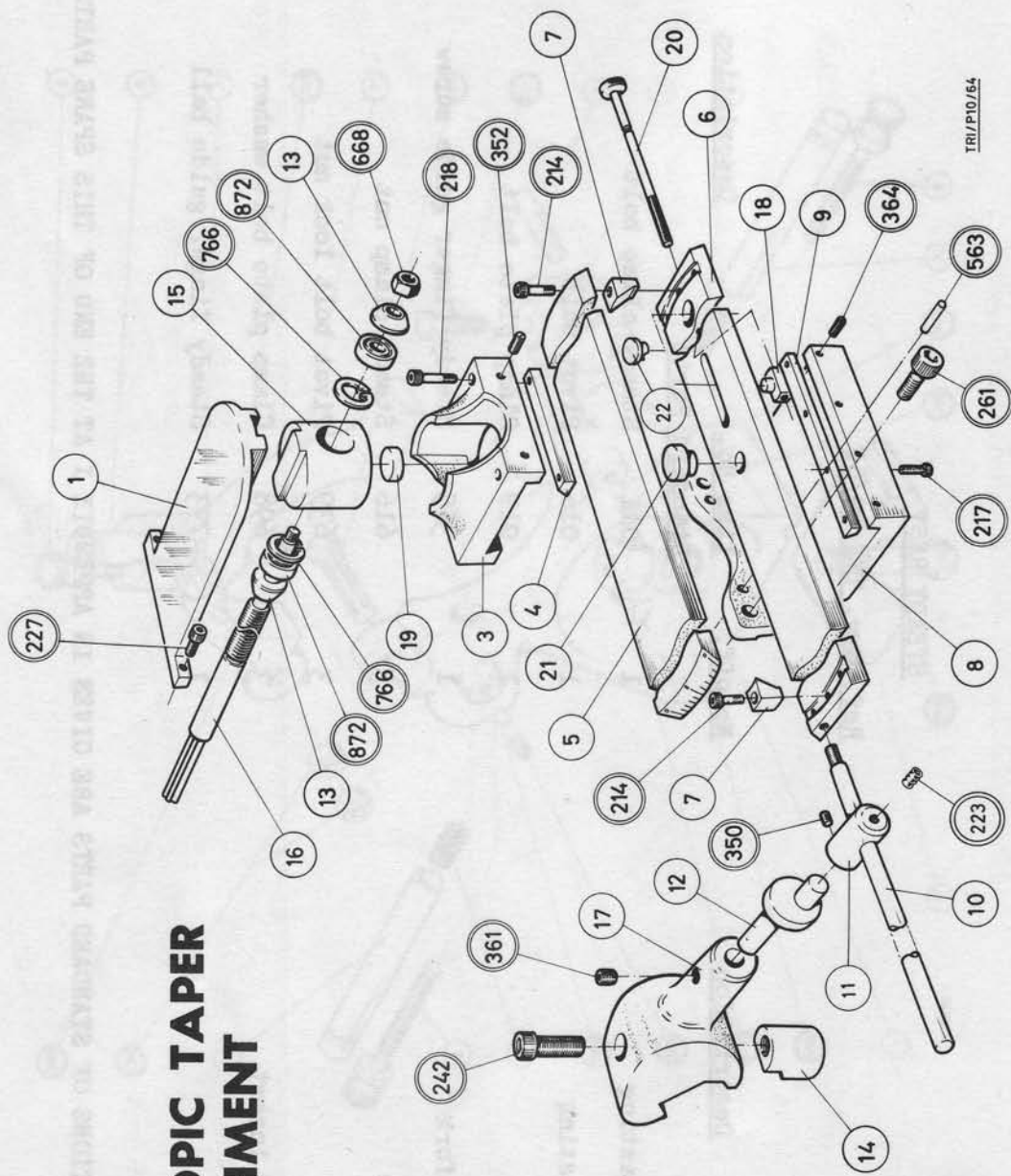

TRI/P10/64

TELESCOPIC TAPER ATTACHMENT

Ref. Dwg. TRI/P10/64

<u>Item No.</u>	<u>Description</u>	<u>No. off.</u>	<u>Item No.</u>	<u>Description</u>	<u>No. off.</u>
1	Bottom slide extension	1	21	Pivot peg	1
3	Slide block	1	22	Adjusting screw keep	1
4	Slide block strip	1			
5	Swivel slide	1			
6	Plate	1			
7	Slideway clamp	1			
8	Taper turner bracket	1			
9	Bracket strip	1			
10	Connecting rod	1			
11	Anchor bracket extension	1			
12	Eccentric pin	1			
13	Bearing housing washer	2			
14	Anchor bracket clamping piece	1			
15	Bearing housing	1			
16	Taper turner saddle screw	1			
17	Anchor bracket	1			
18	Swivel slide adjusting screw nut	1			
19	Bearing housing spacer	1			
20	Swivel slide adjusting screw	1			
			<u>Standard Parts</u>		
			217	Bracket strip securing screw	4
			218	Securing screw for Pt. 4	2
			214	Slideway clamp screw	2
			227	Securing screw for Pt. 1	2
			242	Retaining screw for Pt. 14	1
			261	Securing screw for Pt. 8	2
			223	Connecting rod locking screw	1
			361	Eccentric pin locking screw	1
			350	Locking screw for Pt. 11	2
			364	Bracket strip adjusting screw	3
			352	Adjusting screw for Pt. 4	2
			563	Location dowel for Pt. 8	2
			668	Bearing housing locking nut	1
			766	Bearing housing circlip	2
			872	Saddle screw bearing	2

SPECIFICATIONS OF STANDARD PARTS ARE GIVEN IN APPENDIX I AT THE END OF THIS SPARE PARTS SECTION

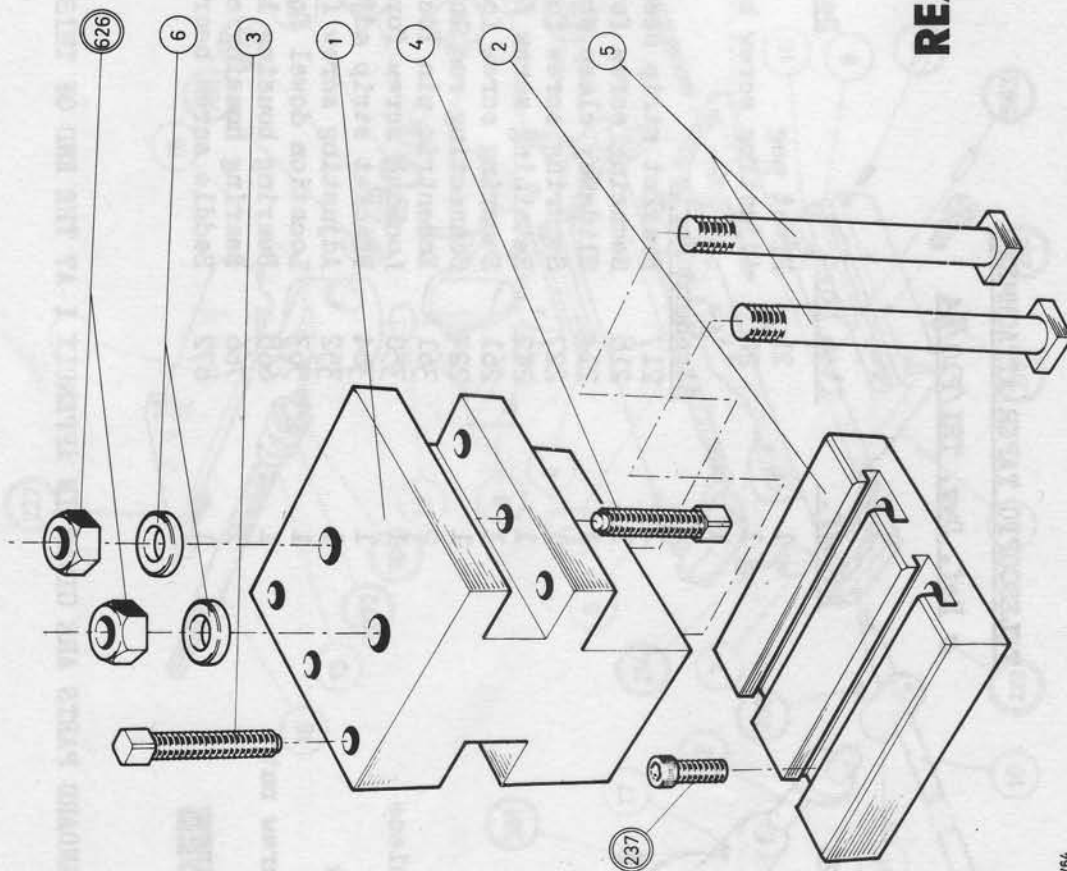

REAR TOOLPOST

TR/P11/64

TURNER STOP AND BED STOP

Ref. Dwg. No. 2100b

REAR TOOLPOST

Ref. Dwg. TRI/PII/64.

<u>Item No.</u>	<u>Description</u>	<u>No.off.</u>	<u>Item No.</u>	<u>Description</u>	<u>No.off.</u>
1	Tool block	1	6	Tool block clamping washers	2
2	Base plate	1			
3	Tool screws - long	3	<u>Standard Parts</u>		
4	Tool screws - short	3	237	Base plate securing screws	4
5	Tool block clamping bolts	2	626	Tool block clamping nuts	2

SPECIFICATIONS OF STANDARD PARTS ARE GIVEN IN APPENDIX I AT THE END OF THIS SPARE PARTS SECTION

SPECIFICATIONS OF STANDARD PARTS ARE GIVEN IN APPENDIX I AT THE END OF THIS SPARE PARTS SECTION

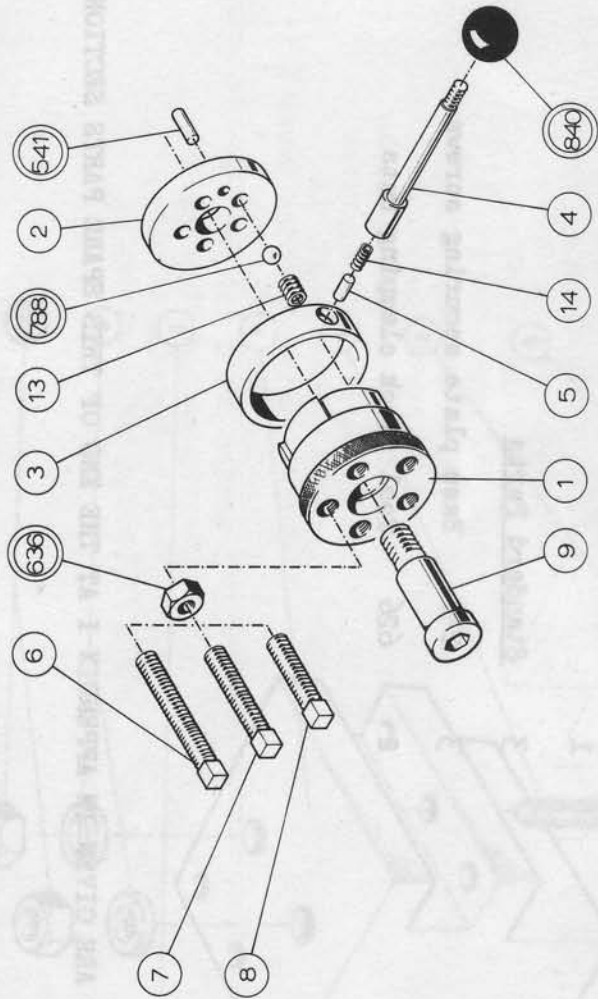

STU/P21/63

REAR TOOLPOST

TURRET STOP AND BED STOP

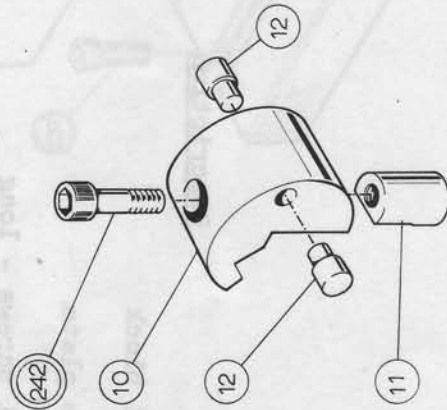

BRONING MILL
 SERIES 300 HYDRAULIC

TURRET STOP AND BED STOP

Ref. Dwg. STU/P21/63

<u>Item</u>	<u>Description</u>	<u>No. off.</u>
1	Turret	1
2	Turret plate	1
3	Lever ring	1
4	Ratchet lever	1
5	Ratchet location pin	1
6	Stop screw 3" long	1
7	Stop screw 2.1/4" long	2
8	Stop screw 1.1/8" long	2
9	Turret spindle	1
10	Bed stop block	1
11	Clamping piece	1
12	Pad	1
	<u>Standard Parts</u>	
242	Clamping piece retaining screw	1
636	Stop screw lock nut	5
541	Turret plate locating pin	1
788	Turret location ball	1
840	Ratchet lever knob	1

SPECIFICATIONS OF STANDARD PARTS ARE GIVEN IN APPENDIX I AT THE END OF THIS SPARE PARTS SECTION

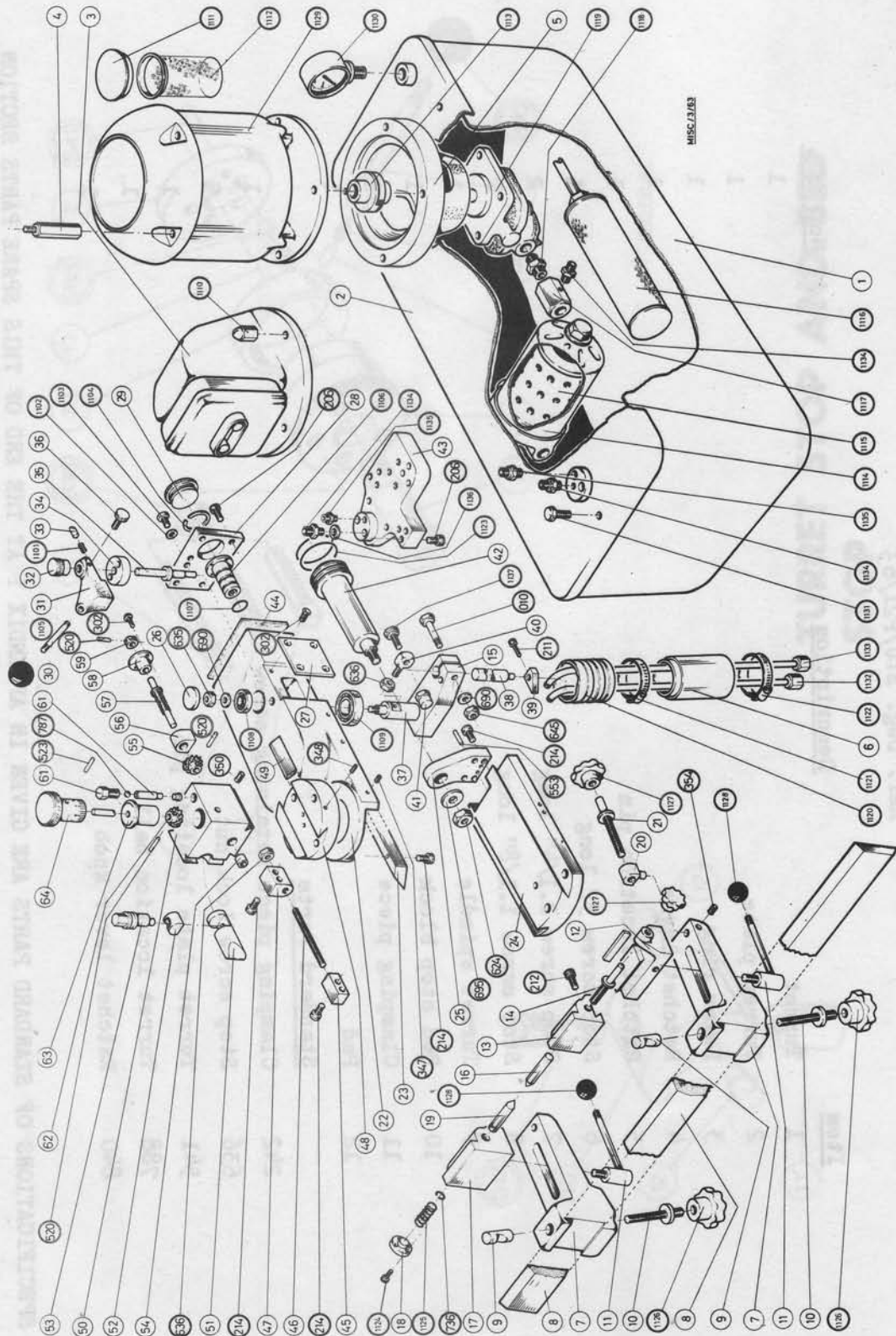

**SERIES 300 HYDRAULIC
PROFILING UNIT**

DIMENSIONS ON REMOVED SPINDLE ARE GIVEN IN THE LIST OF PARTS
 DIMENSIONS ON REMOVED SPINDLE ARE GIVEN IN THE LIST OF PARTS
 DIMENSIONS ON REMOVED SPINDLE ARE GIVEN IN THE LIST OF PARTS

DIMENSIONS ON REMOVED SPINDLE ARE GIVEN IN THE LIST OF PARTS
 DIMENSIONS ON REMOVED SPINDLE ARE GIVEN IN THE LIST OF PARTS
 DIMENSIONS ON REMOVED SPINDLE ARE GIVEN IN THE LIST OF PARTS

TYPE "700" HYDRAULIC PROFILING ATTACHMENT

Ref. Dwg. MISC/3/63

Item No.	Description	No.off.	Item No.	Description	No.off.	Item No.	Description	No.off.
1	Hydraulic tank	1	44	End plate gasket	1	645	Locking nut for Pt. 38	1
2	Hydraulic tank cover	1	45	Stop bar bracket	1	690	Clamp bolt washer	1
3	Starter support bracket	1	46	Screwed stop bar	1	691	Bearing retaining washer	1
4	Support bracket stud	4	47	Stop bracket	1	695	Retaining washer for Pt. 42	1
5	Motor mounting flange	1	48	Toolholder base plate	1	736	Centre retaining circlip	1
6	Flexible conduit adapter	1	49	Toolholder set cover plate	1	787	Thrust ball	1
7	Tailstock mounting bracket	1	50	Toolholder block	1	1101	Detent spring	1
8	Tailstock support beam	2	51	Toolholder locking plunger	1	1102	Oil seal for bleed bolts	2
9	Bracket clamping segments	2	52	Locking plunger insert	1	1103	Bleed bolts	2
10	Segment clamping screws	2	53	Locking plunger eccentric shaft	1	1104	Inspection plug sealing circlip	1
11	Centre bracket clamp bolt	2	54	Toolholder block leadscrew bush	1	1105	Operation shaft knob	1
12	Adjusting centre base	1	55	Leadscrew spiral gear	1	1106	Central cartridge assembly	1
13	Adjusting centre housing	1	56	Leadscrew nut	1	1107	Cartridge "O" ring	5
14	Centre adjusting screw	1	57	Leadscrew	1	1108	Stylus lever top bearing	1
15	Base set over strip	1	58	Leadscrew thrust bearing	1	1109	Stylus lever bottom bearing	1
16	Adjustable centre	1	59	Leadscrew locknut	1	1110	Retaining nuts for Pt. 4	4
17	Spring centre housing	1	60	Locking insert pad	1	1111	Filler cap	1
18	Spring retaining cap	1	61	Locking plunger	1	1112	Filter	1
19	Spring centre	1	62	Locking bolt	1	1113	Flexible drive coupling	1
20	Adjusting screw support	1	63	Adjusting shaft spiral gear	1	1114	Oil filter assembly	1
21	Adjusting screw	1	64	Adjusting shaft bearing	1	1115	Oil filter element	1
22	Profile slide main casting	1	65	Adjusting shaft	1	1116	Metal oil filter	1
23	Profile slide gib	1	66	Adjusting handwheel	1	1117	Oil junction	1
24	Profile slide base	1				1118	Pump adapter	1
25	Piston support bracket	1				1119	Plug assembly	1
26	Stylus arm cover plug	1				1120	Flexible conduit	1
27	Cover plate for adjusting screw	1				1121	Jubilee clip	1
28	Profile slide and plate	1				1122	Jubilee clip	1
29	End plate plug	1				1123	Piston rings for Pt. 42	2
30	Operating shaft	1				1124	Retaining screws for Pt. 18	4
31	Shaft support bracket	1				1125	Centre spring	1
32	Feed adjustment control	1				1126	Tailstock clamping handles	2
33	Detent plunger	1				1127	Adjusting handles	2
34	Eccentric shaft keep	1				1128	Clamp lever knobs	2
35	Eccentric shaft	1				1129	Pump motor	1
36	Support bracket lock screw	1				1130	Pressure gauge	1
37	Stylus lever	1				1131	Tank lid fixing bolt	3
38	Stylus lever shaft	1				1132	Hydraulic pipe - large bore	2
39	Stylus	1				1133	Hydraulic pipe - small bore	1
40	Valve operating eyebolt	1				1134	Pipe adapter	4
41	Adjusting screw locknut	1				1135	Pipe adapter	7
42	Main profiler piston	1				1136	Oil seal washers	4
43	Port plate	1				1137	Tapper screw	1

SPECIFICATIONS OF STANDARD PARTS ARE GIVEN IN APPENDIX I AT THE END OF THIS SPARE PARTS SECTION

RAPID-THREADER ATTACHMENT

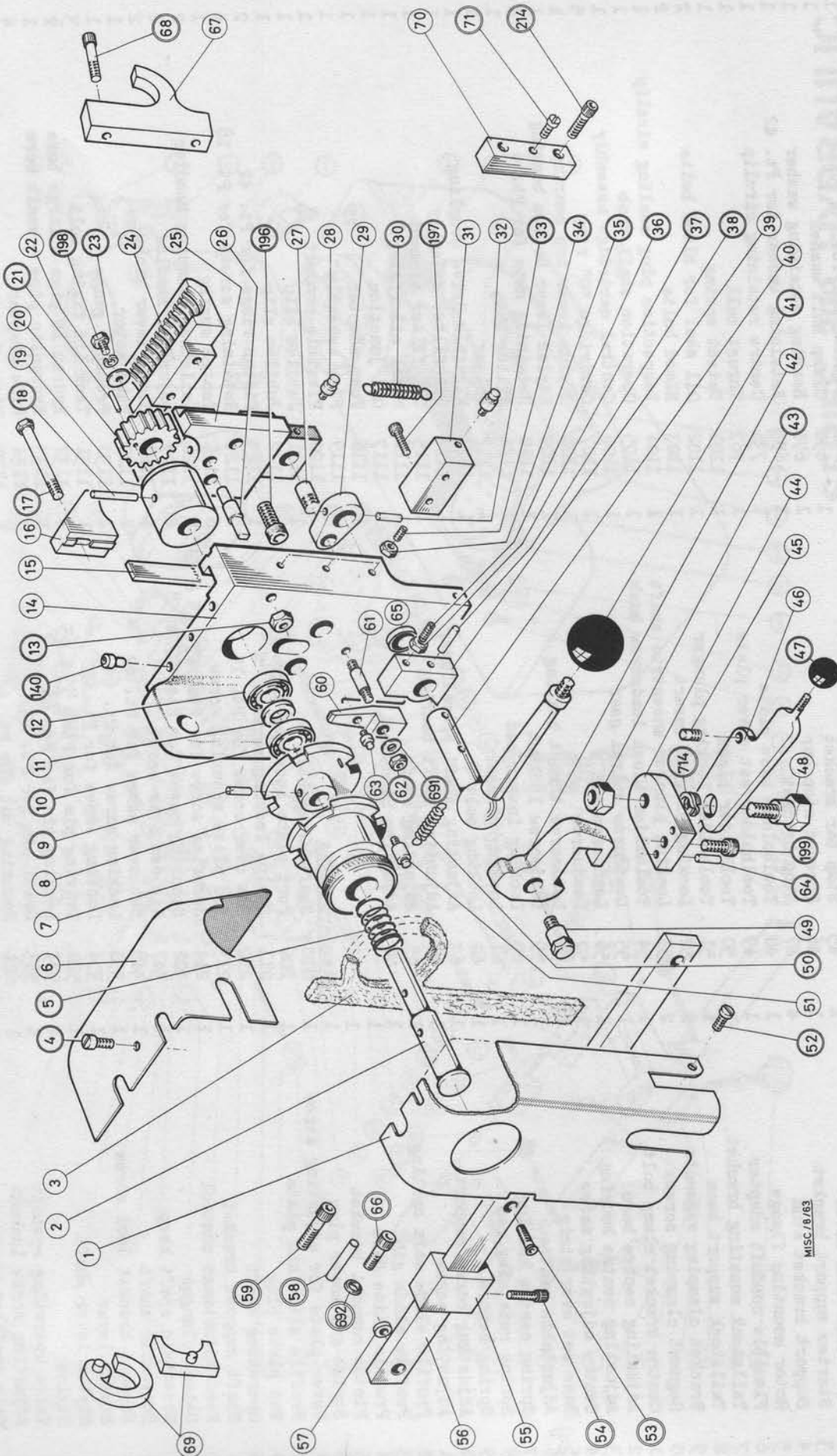

MISC / 8 / 63

RAPID-THREADER ATTACHMENT - English

Ref. Dwg. MISC/8/63

Item No.	Description	No.off.	Item No.	Description	No.off.
1	Front cover	1	65	Handle shaft bearing	1
2	Setting dial assembly (Assy. includes items 5, 7, 8 & 9)	1	66	Centre hole mounting screw	1
3	Cover sealing felt	1	67	Lower steady (8 1/2" or 17" lathes only)	1
4	Cover fixing screws	2	68	Lower steady screw	2
5	Spring (Included in item 2)	1	69	Half-nut lever lock - "C" type - Plate type (8 1/2" or 17" only)	1
6	Back cover	1	70	Cover spacing block (later models)	1
7	Dial housing (Included in item 2)	1	71	Cover spacing block screw (later models)	1
8	Dial plate (Included in item 2)	1			
9	Dowel (Included in item 2)	1			
10	Ball race - Hoffman	1			
11	Ball race spacer	1			
12	Ball race - Hoffman	1			
13	Steady adjusting nut	1			
14	Main bracket	1			
15	Gib	1			
16	Steady bolt	1			
17	Steady pin	1			
18	Pinion driving collar	1			
19	Pinion	1			
20	Pin (Included in Pinion, item 20)	1			
21	Pinion retaining washer	1			
22	Pinion retaining screw	1			
23	Lock washer	1			
24	Half nut	1			
25	Slide	1			
26	Selector pin	1			
27	Slide driving pin	1			
28	Spring retaining pin	1			
29	Cam-handle shaft assembly (Assy. includes items 33, 38, 39 & 40)	1			
30	Main spring	1			
31	Spring anchor block	1			
32	Spring retaining pin	1			
33	Dowel (Included in item 29)	1	140	Oil nipple	2
34	Gib adjusting screws	3	196	Half-nut screws	2
35	Gib adjusting screw locknut	3	197	Spring anchor block screws	2
36	Locking lever adjusting screw	1	198	Pinion retaining screw	1
37	Locking lever adjusting screw locknut	2	199	Knock-off bracket screws	2
38	Dowel (Included in item 29)	1	214	Cover spacing block screws	2
39	Block (Included in item 29)	1	227 †	Mounting screws (for 6" & 6 1/2" lathes)	2
40	Handle (Included in item 29)	1	228 †*	Mounting screws (for 6", 6 1/2" & 7 1/2" lathes)	3
41	Handle knob	1	229 *	Centre hole mounting screws (for 7 1/2" lathes)	1
42	Disengaging lever	1	242 †	Mounting screws (for 8 1/2" lathes)	2
43	Knock-off lever pivot locknut	1	244 *	Centre hole mounting screws (for 8 1/2" lathes)	1
44	Knock-off lever bracket	1	691	Locking lever pivot washer	1
45	Boss for knock-off lever	1	692	Centre hole mounting screw washer (for 6" & 7 1/2" lathes)	1
46	Knock-off lever	1	714	Knock-off lever friction washer	1
47	Knock-off lever knob	1			
48	Knock-off lever pivot screw	1			
49	Disengaging pivot screw	1			
50	Locking lever spring	1			
51	Spring anchor	1			
52	Front cover screw	1			
53	Stop bar screw	1			
54	Stop adjusting screw	1			
55	Adjustable stop	1			
56	Stop bar (to suit lathe)	1			
57	Stop bar spacer	1			
58	Dowel pin	1			
59	Mounting screw (to suit lathe)	1			
60	Locking lever	1			
61	Locking lever pivot stud	1			
62	Locking lever pivot nut	1			
63	Pin for locking lever	1			
64	Dowel for knock-off lever (not later models)	1			

† Item No. 59 refers:
Size selected for lathe
* Item No. 66 refers:
Size to suit lathe

SPECIFICATIONS OF STANDARD PARTS ARE GIVEN IN APPENDIX I AT THE END OF THIS SPARE PARTS SECTION

APPENDIX 1

SPECIFICATION OF STANDARD PARTS

Item No.

001	Woodruff Key	No. 3.
002	" "	No. 9.
009	Feather Key	1/4" x 1/3" x 1".
011	Hex. Head Bolt	3/8" UNC x 1.1/4".
015	" " "	1/2" " x 1.3/4".
021	" " "	7/8" " x 4".
032	Ball Journal	Hoffman XLS 2.1/4".
058	Taper Washer	3/8" I/D x 5".
060	Oilring Type B 4/115	1/2" I/D.
061	Ball Journal	Hoffman XLS 2.
062	Oilseal - Weston W 16211237 R	1.1/8" I/D x 1.628 x 3/8".
180	Ball Journal.	Hoffman 2 1/8" x 1 1/8" x 3/8".
181	Oilseal - Weston	WB 16911037 R21.
182	Washer Dowty	List 5MK 10PP 49C.
183	Needle Bearing Ina	SC 1412. 1 1/8" x 7/8" x 3/4".
184	" " "	SC 128 1" x 3/4" x 1/2".
201	Socket Cap Head Screw	No. 10 - 24 t.p.i. x 3/8".
202	" " " "	No. 10 - 24 " x 1/2".
203	" " " "	No. 10 - 24 " x 5/8".
206	" " " "	No. 10 - 24 " x 1".
207	" " " "	No. 10 - 24 " x 1.1/4".
212	" " " "	1/4" UNC x 1/2".
213	" " " "	1/4" " x 5/8".
214	" " " "	1/4" " x 3/4".
215	" " " "	1/4" " x 7/8".
216	" " " "	1/4" " x 1".
217	" " " "	1/4" " x 1.1/4".
218	" " " "	1/4" " x 1.1/2".
219	" " " "	1/4" " x 1.3/4".
223	" " " "	5/16" " x 1/2".
225	" " " "	5/16" " x 3/4".
228	" " " "	5/16" " x 1.1/4".
229	" " " "	5/16" " x 1.1/2".
230	" " " "	5/16" " x 1.3/4".
231	" " " "	5/16" " x 2".
242	" " " "	3/8" " x 1.1/2".
246	" " " "	3/8" " x 2.1/2".
253	" " " "	7/16" " x 2".
260	" " " "	1/2" " x 1.1/2".
300	Socket Countersunk Head Screw	No. 10 - 24 t.p.i x 1/4".
314	" " " "	1/4" UNC x 1.3/8".
318	" " " "	5/16" " x 3/4".
319	" " " "	5/16" " x 1".
342	Socket Head Set Screw	No. 10 - 24 t.p.i x 3/16".
343	" " " "	No. 10 - 24 " x 1/4".
344	" " " "	No. 10 - 24 " x 5/16".
345	" " " "	No. 10 - 24 " x 3/8".
350	" " " "	1/4" UNC x 1/4".
351	" " " "	1/4" " x 5/16".
355	" " " "	1/4" " x 5/8".
361	" " " "	5/16" " x 5/16".
362	" " " "	5/16" " x 3/8".

SPECIFICATION OF STANDARD PARTS (CONTINUED)

Item No.

363	Socket Head Set Screw	5/16" UNC x 7/16".
365	" " " "	5/16" " x 5/8".
366	" " " "	5/16" " x 3/4".
378	" " " "	7/16" " x 7/16".
419	Socket Head Set Screw 1/2 dog	1/4" UNC x 3/8".
429	" " " " " "	5/16" x 3/8".
485	Socket Countersunk Head Screw	2 BA x 3/8".
495	Socket Cap Head Screw	3 BA x 5/8".
497	" " " "	3 BA x 1.1/4".
520	Mills Pin GP 1	1/8" x 1/2".
539	" " GP 3	5/16" x 1/2".
541	" " GP 3	3/16" x 5/8".
542	" " GP 3	3/16" x 3/4".
543	" " GP 3	3/16" x 7/8".
544	" " GP 3	3/16" x 1".
545	" " GP 3	3/16" x 1.1/4".
546	" " GP 3	3/16" x 1.1/2".
547	" " GP 4	3/16" x 5/8".
558	" " GP 3	1/4" x 3/8".
559	" " GP 3	1/4" x 1.1/8".
563	" " GP 3	1/4" x 1.1/4".
577	" " GP 4	5/16" x 1".
579	" " GP 3	1/8" x 5/16".
590	" " GP 3	3/8" x 1.3/4".
607	Grover Spring Dowel Pin	3/16" x 15/16".
612	Deep Nut - Steel	3/8" UNC.
621	Standard Nut - Steel	5/16" "
622	" " "	3/8" "
623	" " "	7/16" "
624	" " "	1/2" "
632	" " "	No. 10-24 t.p.i.
636	" " "	3/8" UNC.
637		
644	Thin Locknut	1/2" "
650	Nyloc Nut	3/8" UNF.
651	" "	7/16" "
652	" "	1/2" "
654	" "	5/8" "
659	Simmonds Aero Nut	5/16" UNC.
660	Nyloc Nut	3/8" "
663	Wedglock Nut	1/2" "
675	Simmonds Nut Type T	5/8" UNF.
692	BS Steel Washer	5/16" I/D.
693	" " "	3/8" I/D.
694	" " "	7/16" I/D.
695	" " "	1.1/2" I/D.
698	" " "	5/8" I/D.
716	Double Coil Spring Washer - Light Series	1/2" I/D.
718	Double Coil Spring Washer - Light Series	5/8" I/D.
725	Schnoor Disc Spring Washer Type K	Size 6201.
736	External Circlip - Type 1400 - Anderton	1/2" Dia.

SPECIFICATION OF STANDARD PARTS (CONTINUED)

Item No.

743	External Circlip - Type 1400 - Anderton	5/8" Dia.
744	External Circlip - Type 5101/66 - Salter	11/16" Dia.
745	External Circlip - Type 5101/66 - Salter	3/4" Dia.
749	External Circlip - Type 5101/66 - Salter	7/8" "
754	External Circlip - Type 5101/66 - Salter	1.1/8" Dia.
766	External Circlip - Type 1300 - Anderton	28 mm Dia.
773	Internal Circlip - Type 1300 - Anderton	3.464" Dia.
774	Internal Circlip - Type 1300 - Anderton	2.1/8" Dia.
778	"E" Type Circlip - Type 1500 - Anderton	5/16" Dia.
782	"E" Type Circlip - Type E 210 - Anderton	1.1/4" Dia.
786	Steel ball.	5/32" "
788	" "	1/4" "
789	" "	5/16" "
790	" "	3/8" "
792	" "	5/8" "
793	Pho. Bronze Ball	1/4" "
795	Compression Spring	1/4" O/D x 1/2" FL. x 22 SWG.
803	Compression Spring	5/16" O/D x 1.1/4" FL.
813	" "	1.3/8" O/D x 1" FL.
815	Extension Spring	5/16" O/D x 1.7/8" OA.
817	Standard Extension Spring	1/2" O/D x .080" x 2.3/16" OA.
827	Garland Diaphragm Oiler	1/4" Dia.
828	Winkley Oiler	5/16" Dia.
830	Plastic Knob - Black	1.1/2" O/D x 7/16" UNC.
833	" " - Red	1.1/2" O/D x 5/16" "
835	" " - Black	1.1/4" O/D x 7/16" "
836	" " - "	1.1/2" O/D x 7/16" "
838	" " - "	1" O/D x 3/8" UNC.
840	" " - "	3/4" O/D x 1/4" UNC.
841		
846	Oilring-Pioneer	P.O. 06204310.
852	" -Dowty	1.484" I/D x .139".
855	" -Pioneer	P.O./23720021.
858	" - "	P.O.52506/MP/658.
863	Oilseal-Weston W 1620037	1" I/D x 1.5/8" O/D x 3/8".
865	" -Weston W 16912537	1.1/4" I/D x 1.11/16". O/D x 3/8".
871	Oilsight - Tecalemit I.C. 4610	1.1/4" O/D.
872	Thrust Bearing	Hoffman A 10.
882	Thrust Bearing	Hoffman 5/8" WSP.
885	Thrust Bearing	Hoffman W 1.1/4".
886	Needle Bearing Ina	HK. 1516 21mm x 15mm x 16mm.
887	" " "	SC 1212 1" x 3/4" x 3/4".
888	" " "	SC 1112 7/8" x 11/16" x 3/4".
889	" " "	HK 2820 35mm x 28mm x 20mm.
906	Countersunk Head Rivet	5/32" Dia.
908	Hollow Copper Rivet	5/32" Dia.
997	Brake Shoes	4" Dia. Ferodo