



CLAUSING CORPORATION  
KALAMAZOO, MICHIGAN 49001

**NO. 7228 & 7229  
BED TURRETS**

for

6900 SERIES CLAUSING 14" LATHES

APRIL, 1970

FILE NO. 7229-3

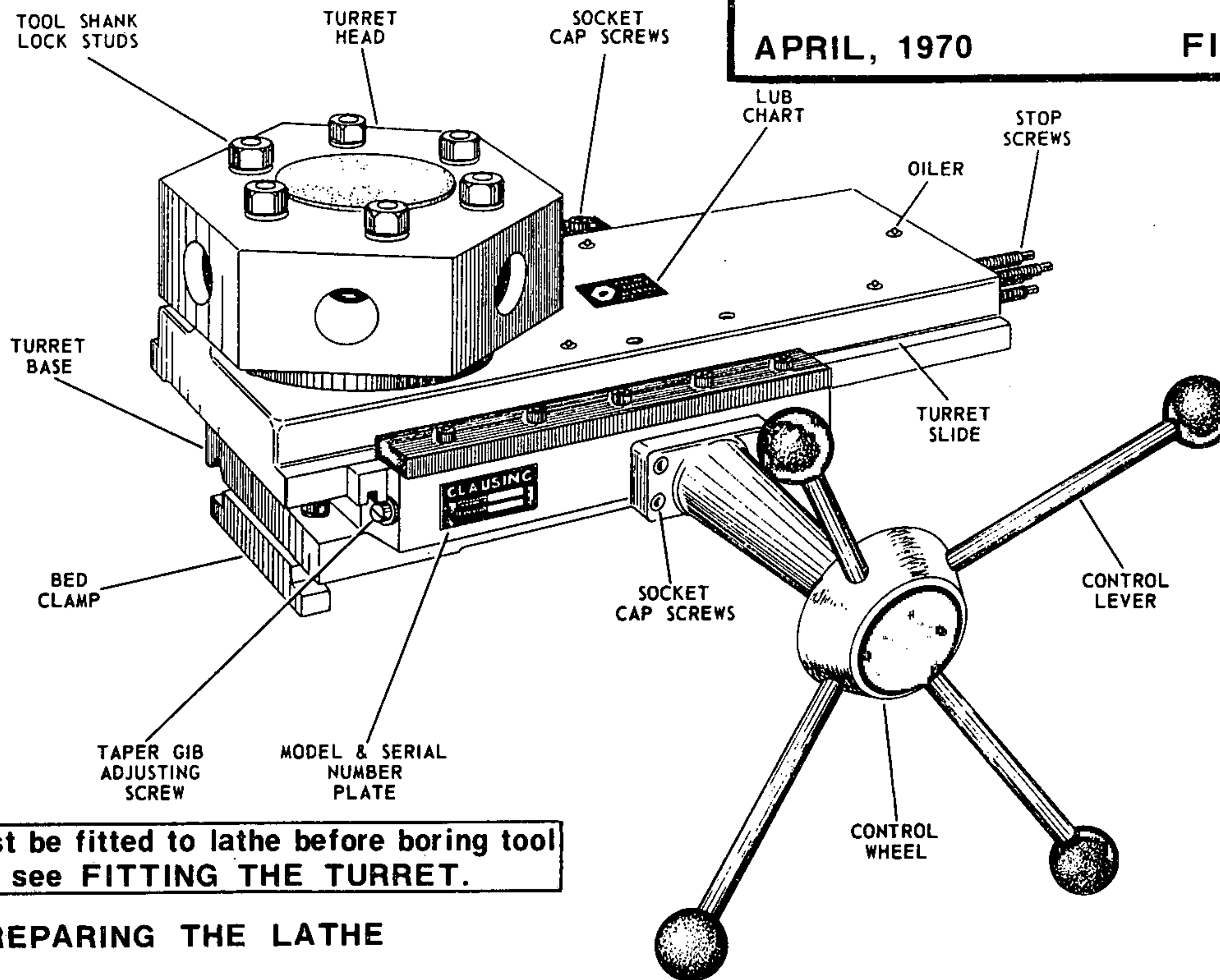

**NOTE:**

**Bed turret must be fitted to lathe before boring tool shank holes – see FITTING THE TURRET.**

**PREPARING THE LATHE**

1. Loosen bed clamp nut and slide tailstock off end of lathe bed.
2. Move carriage toward tailstock end of lathe to provide sufficient space for turret.
3. Wipe the bed ways clean of oil, chips and dirt – remove any marks with a fine emery cloth or hone. **IMPORTANT:** To assure accurate performance, the lathe bed must be level before installing the turret and boring the tool shank holes. Use a sensitive machinist level and take readings parallel and, at right angles to the lathe bed at the headstock and tailstock ends – refer to 6900 Series INSTRUCTION AND PARTS MANUAL.

**FITTING THE TURRET**

1. Remove turret and bag from shipping box. Bag contains 4 control levers, 6 tool shank studs, speed wrench, socket set screw wrench, 6 nylon plugs, 2 clamping plates.
2. Place turret on clean bench with bottom of base up.
3. Use a grease solvent to clean rust proof coating from all machined surfaces – wipe dry with clean cloth.
4. Apply a thin film of blueing to lathe bed ways where turret is to be positioned.
5. To avoid damage, have someone assist in lowering turret into position on lathe bed. Slide turret back and forth over blued section and check for rock by applying pressure on opposite corners front and rear of turret base.

6. Remove turret and check base for good bearing. Blueing will indicate high spots if any on turret bearing pads.

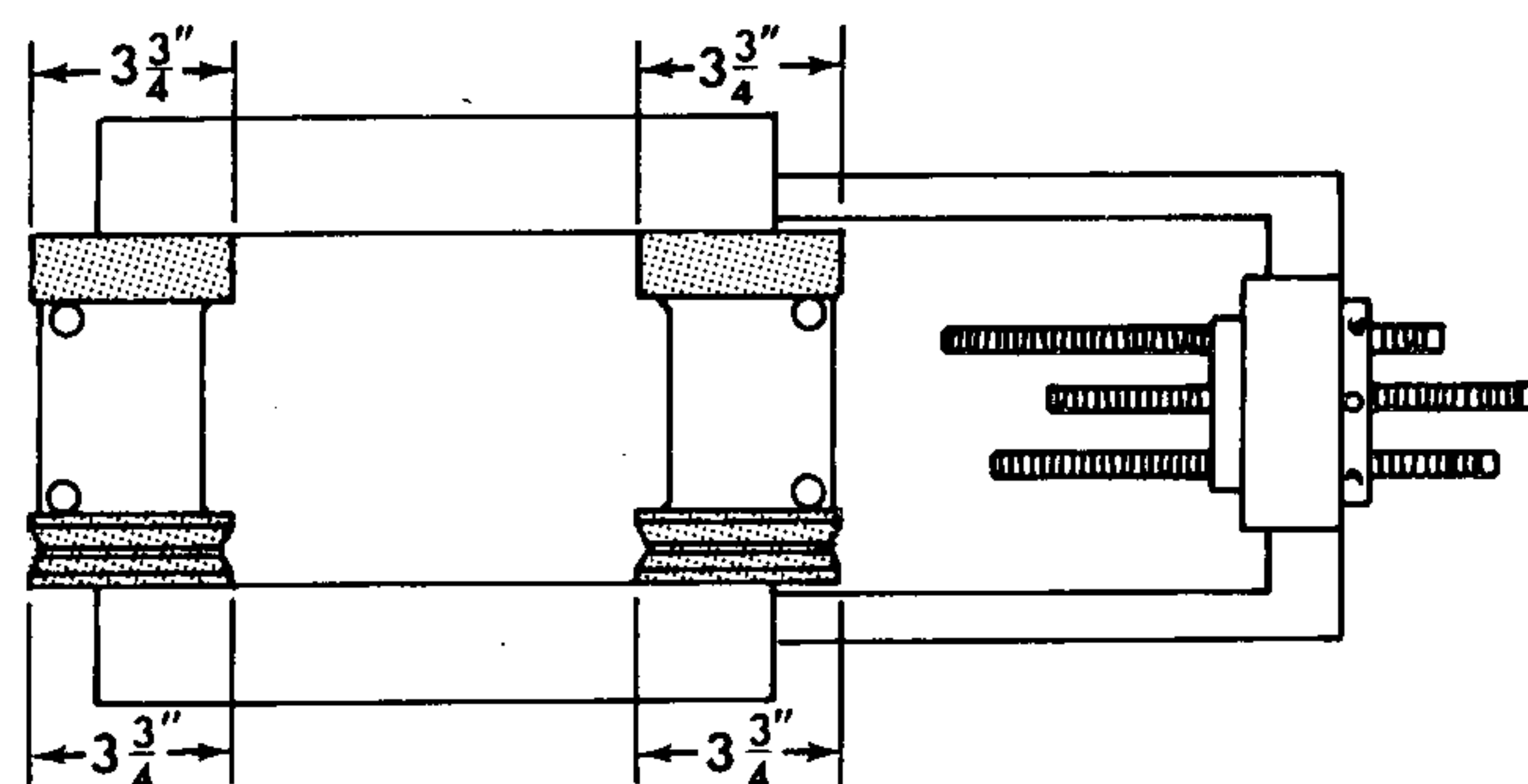

Figure 1

7. Scrape high spots just enough to remove blueing – then place turret back on lathe and check again as in steps 5 and 6. Repeat this procedure until bearing pads bear  $3\frac{3}{4}$ " as shown in figure 1.
8. Wipe bed ways and turret clean. Position turret on lathe and install turret bed clamps. Alternate tightening clamp screws from corner to corner, keeping clamp pressure as equal front and back as possible. Tighten clamp screws just enough to keep turret in place under operating conditions.



## CHECKING ALIGNMENT

1. Remove six stop screws at rear of turret slide.
2. Install one control lever and advance turret approximately 2" or until click is heard, this allows index pin to "pop in" locking turret head.

**CAUTION:** Check to be sure turret head is locked in position. If turret head can't be moved, it is properly locked.

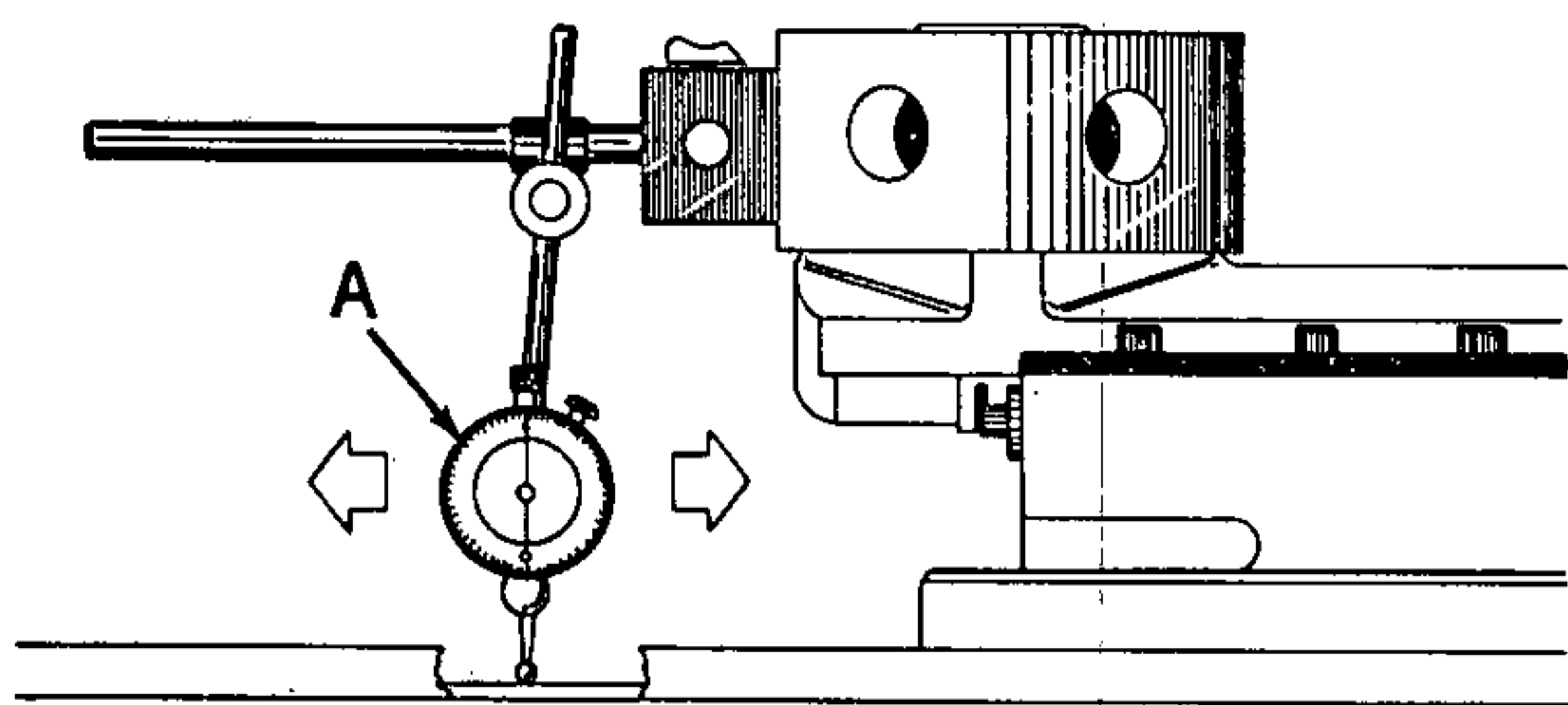

Figure 2

3. Mount indicator (A, Fig. 2) on front of turret head.
4. Set indicator so it bears on flat of lathe bed way.
5. With zero indicator reading, traverse turret slide towards lathe headstock. Indicator should read .000" to -.001" as shown in drawing at right.

**IMPORTANT:** If readings do not fall within .000" to -.001" remove turret and scrape front or rear pads. If a plus reading is obtained, it will be necessary to scrape the rear bearing pads. If a minus reading exceeding -.001" is obtained, it will be necessary to scrape the front bearing pads.

**NOTE:** If scraping is necessary to get alignment, be sure to re-check bearing pads as in steps 5 and 6 page 1.

6. Check lateral alignment following steps 1 through 5 above, except, set indicator to bear on side of lathe bed "V" as shown in drawing at right.
7. To correct lateral alignment, remove turret and scrape opposing sides of turret "V" front and rear in direction desired.

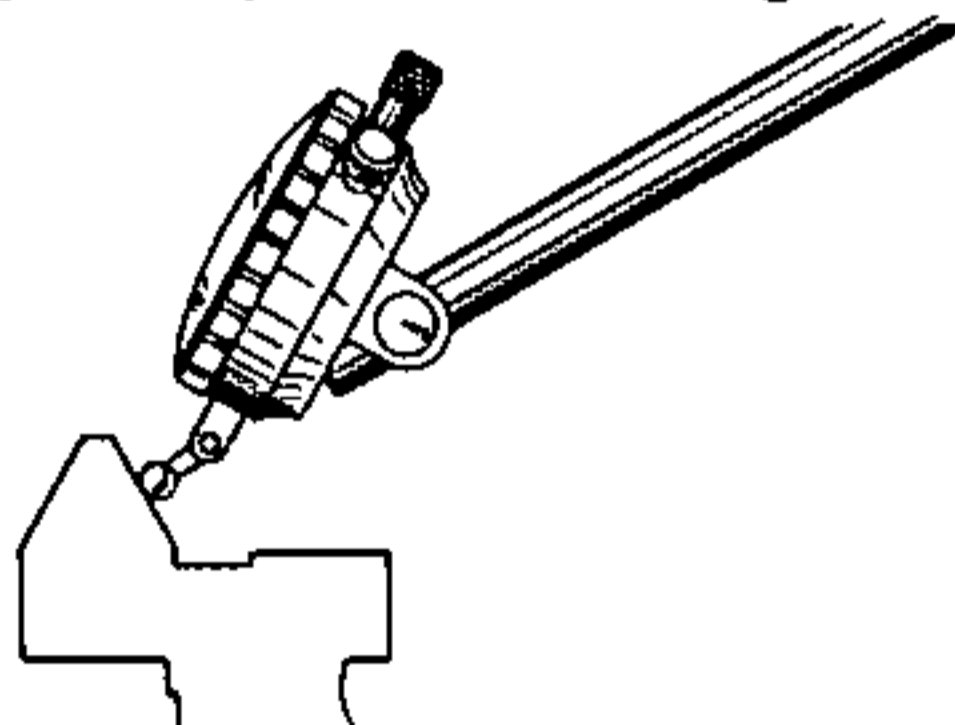
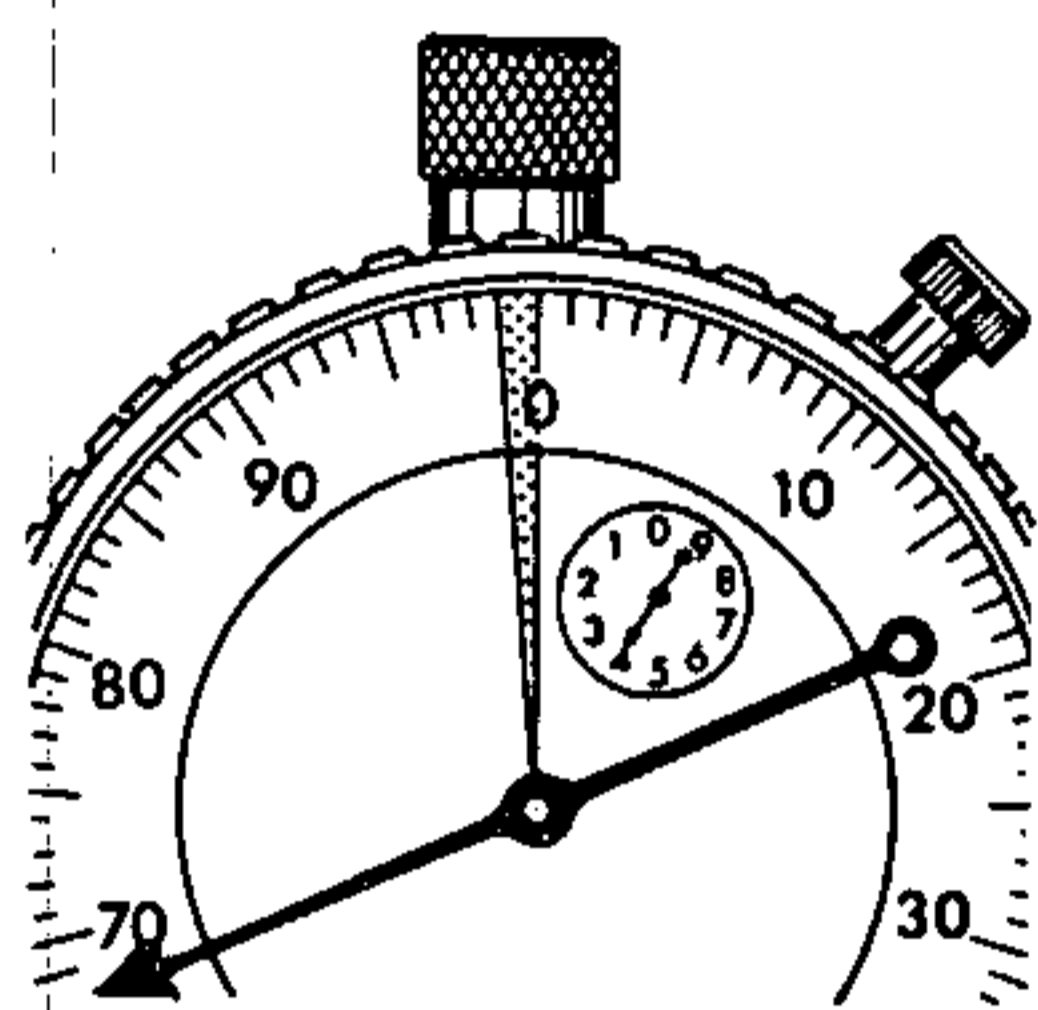

## BORING TOOL SHANK HOLES

The tool shank holes must be concentric and bored to exact size for accurate performance. The holes have been rough bored to  $1\frac{3}{8}$ " diameter and must be finished bored to  $1\frac{1}{2}$ " diameter. The turret head will handle tools with  $1\frac{1}{2}$ " diameter shanks. Study the following procedure before starting boring operation.

1. Remove turret from lathe bed and traverse carriage to tailstock end of lathe.
2. Wipe turret and lathe bed ways clean. Mount turret back on bed ahead of carriage.
3. Make sure tool shank lock studs are NOT in the turret head.
4. Mount a boring bar at least  $1\frac{1}{4}$ " diameter in a 4-jaw chuck. The bar should extend 3" maximum beyond the chuck jaws (the length of the holes in the turret head).

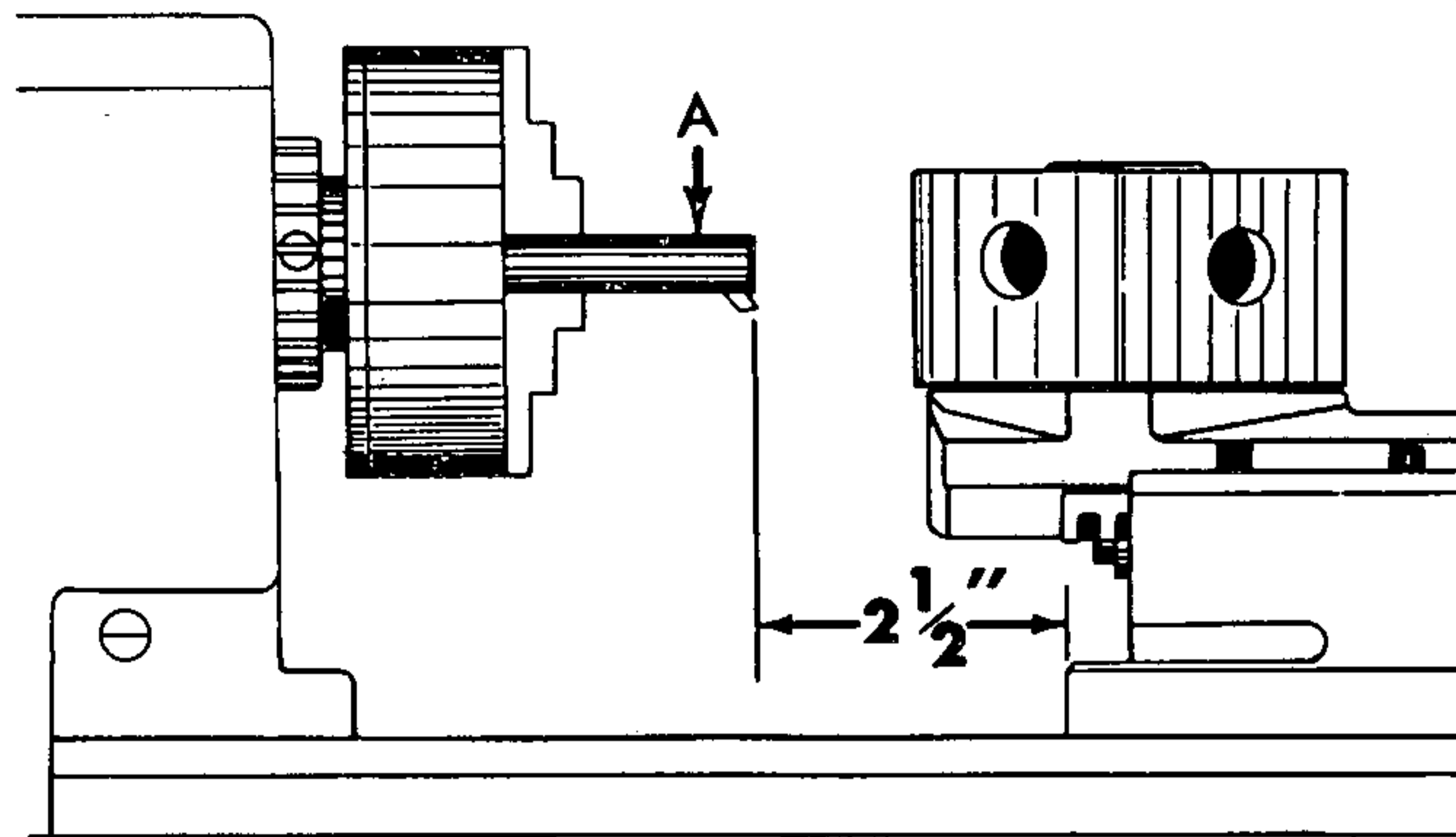

Figure 3

5. Move the turret forward on the lathe bed until the distance between the boring bar cutter (A fig. 3) and the front of the turret base is about 2 1/2". In this location, overhang is at a minimum, and turret can be indexed. Lock turret to lathe bed by tightening clamp plates. (See 8, page 1).
6. Be sure turret head is indexed and locked in position before each boring operation. To check, take hold of head — if it can't be moved, it is properly locked. Repeat this procedure each time the head is turned to the next station.

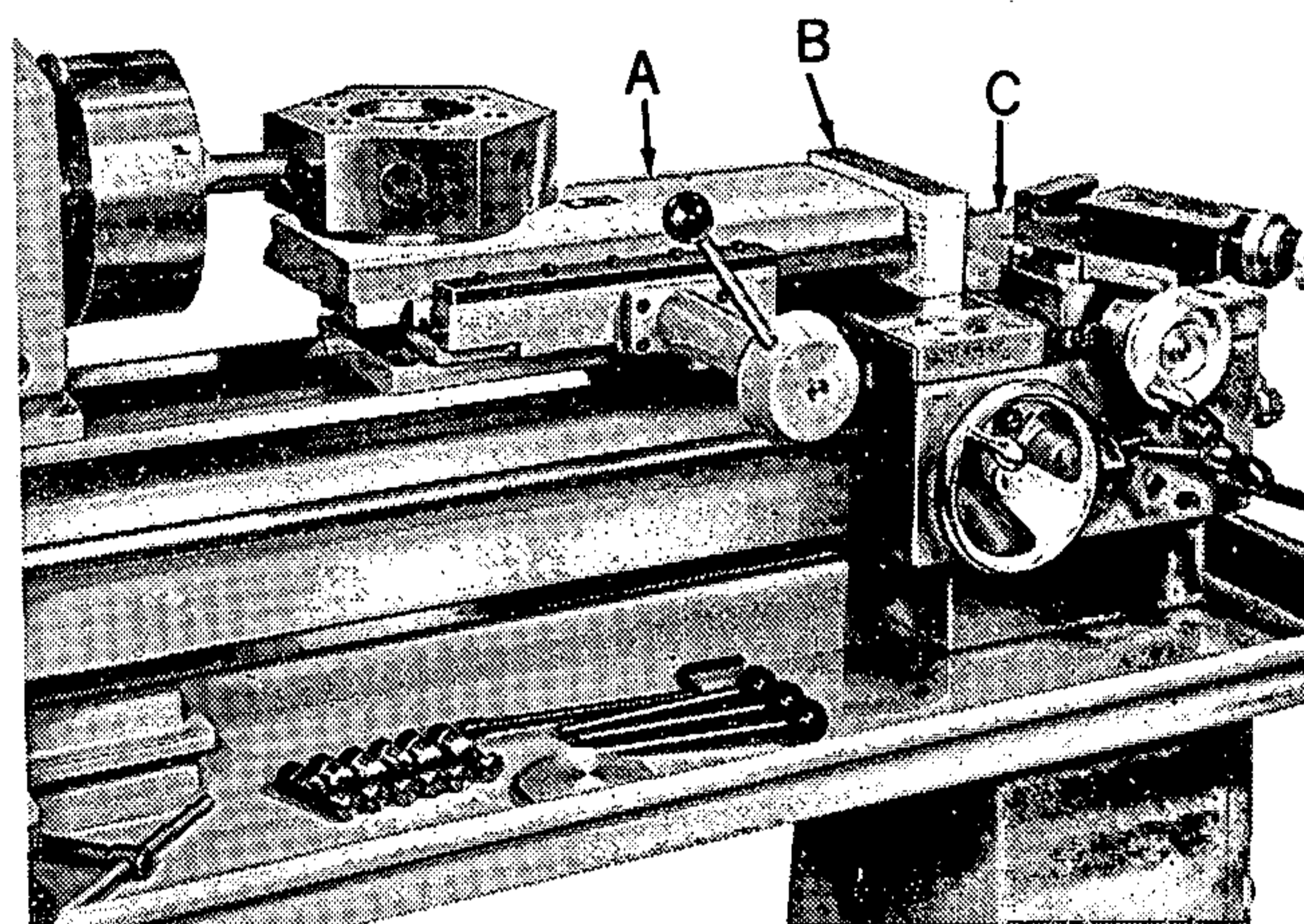

Figure 4

7. Place a wooden block (B, fig. 4) in front of carriage (C) to drive the turret slide (A).
8. Set the lathe quick change gear box for .0022" feed.
9. Bore the tool shank holes with power feed taking at least four cuts to bore holes to  $1\frac{1}{2}$ " diameter — removing .020" on each of the first three cuts, and about .002" to .003" on the fourth or finishing cut.
10. Take roughing cut on first hole and all succeeding holes until all six holes are rough bored. (Starting hole may be indicated with a chalk mark.) Then, take the second roughing cut boring all six holes. Repeat on the third roughing cut, boring out all the holes. Then, finish bore all six holes to  $1\frac{1}{2}$ " diameter.
11. Remove chips after each boring operation.
12. To obtain correct hole size, check with telescoping gauge.
13. After all six holes have been finished to size — clean away all chips, remove clamp screws and lift turret from lathe.



14. Clean lathe bed and move carriage up to the headstock. Wipe bed at tailstock end and install bed turret – tighten clamp plates. (See 8, page 1).
15. Install the 6 tool shank lock studs, 6 stop screws, 6 nylon plugs and set screws and 3 control levers.

### OPERATION AND MAINTENANCE

1. Six adjustable stop screws (A, Fig. 5) – one for each of the turret stations, are located at rear of turret slide.

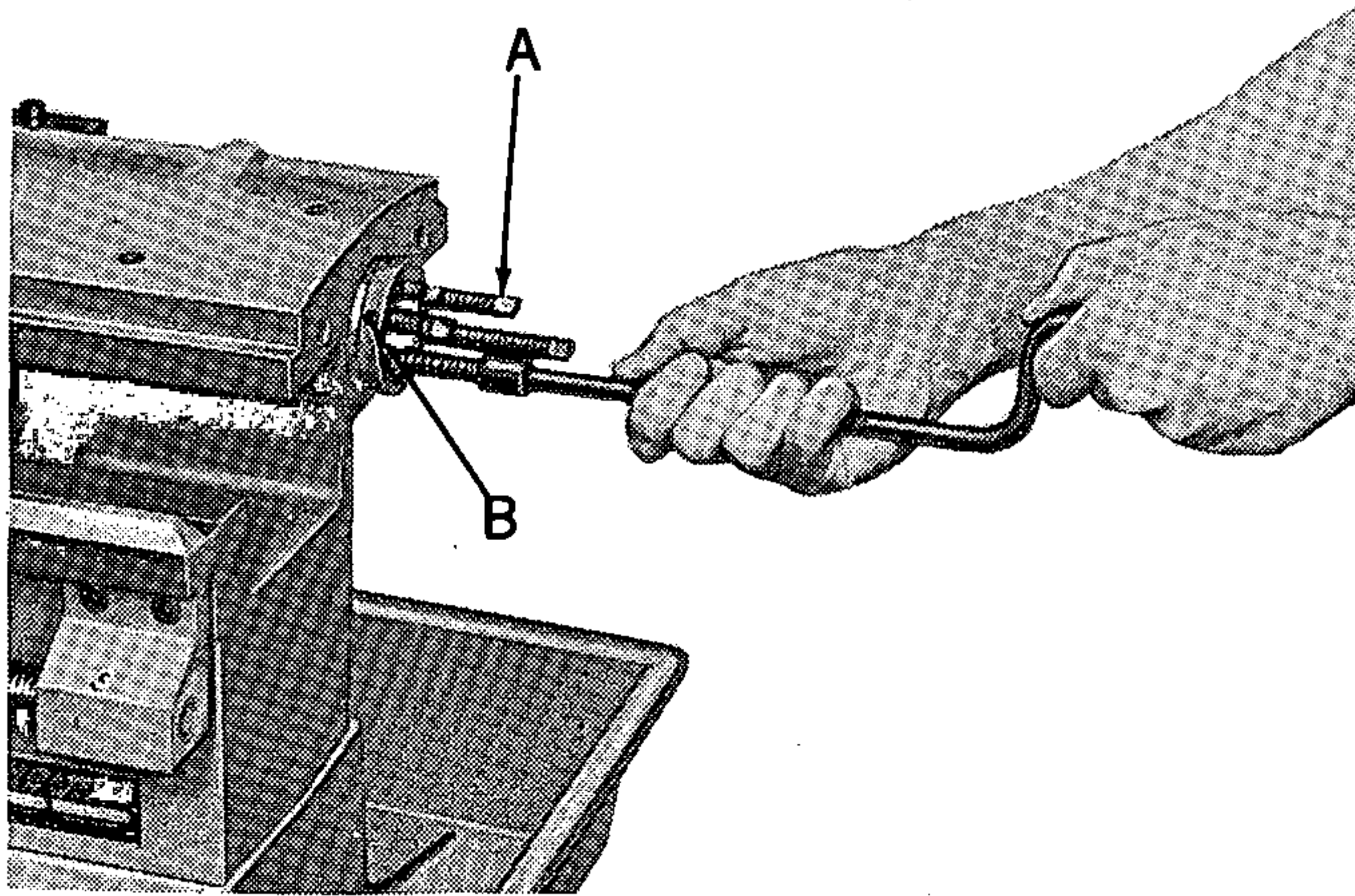

Figure 5

2. To adjust, loosen lock screws (B) in ring and turn screws to position desired – use speed wrench, see figure 5. Tighten lock screws in ring.
3. Make sure turret is indexed and locked before each machining operation.
4. Turret slide should move freely in the turret base, but with no up or down play. Adjustment may be made by removing shim plates.
5. Should lateral play develop, correct by turning taper gib adjusting screws on each end of turret base.
  - (a) To check turret alignment refer to figure 6.
  - (b) Mount a 1-1/2" diameter by 7-1/2" long ground test bar in the turret head, and another exactly the same diameter in lathe spindle or 4-jaw chuck.
  - (c) Clamp a dial indicator to carriage and dial indicate the side of the test bar in the chuck while turning the spindle by hand – reading should be within .001".

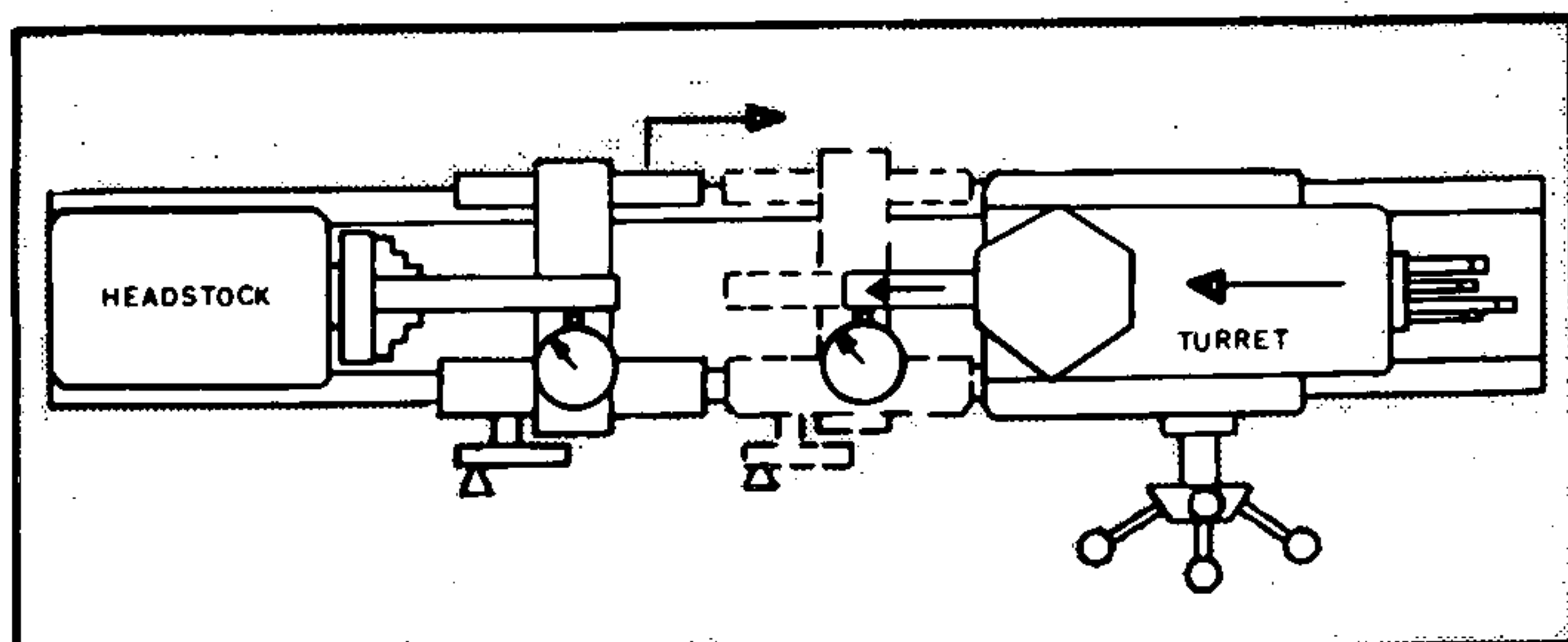

Figure 6

- (d) Without disturbing the dial, move the carriage until the indicator button touches the end of the test bar in the turret – turret slide must be as far back as possible.
- (e) Now adjust the gib screws so the turret test bar is in alignment with chuck test bar.

7. The turret head bearings seldom require adjustment, however, they may be adjusted if excessive play is noticeable.

- (a) Move the slide forward and retract to a point where the lock pin is disengaged from the head, head will spin freely in a clockwise direction.
- (b) Remove head cap and use a socket wrench to tighten the 3/4 esna nut. The head should spin freely but with a slight amount of bearing drag. Replace cap.

**CAUTION:** Over-tightening will cause bearing damage and difficult turret operation.

### IMPORTANT

KEEP YOUR BED TURRET CLEAN – oil and dirt form an abrasive compound which will damage bearing surfaces. Wipe machined surfaces with clean oily rag at frequent intervals.

### LUBRICATION

CODE – D Daily lubricate with TEXACO WAY Lubricant "D" or equivalent.

•Position head as shown on plate.

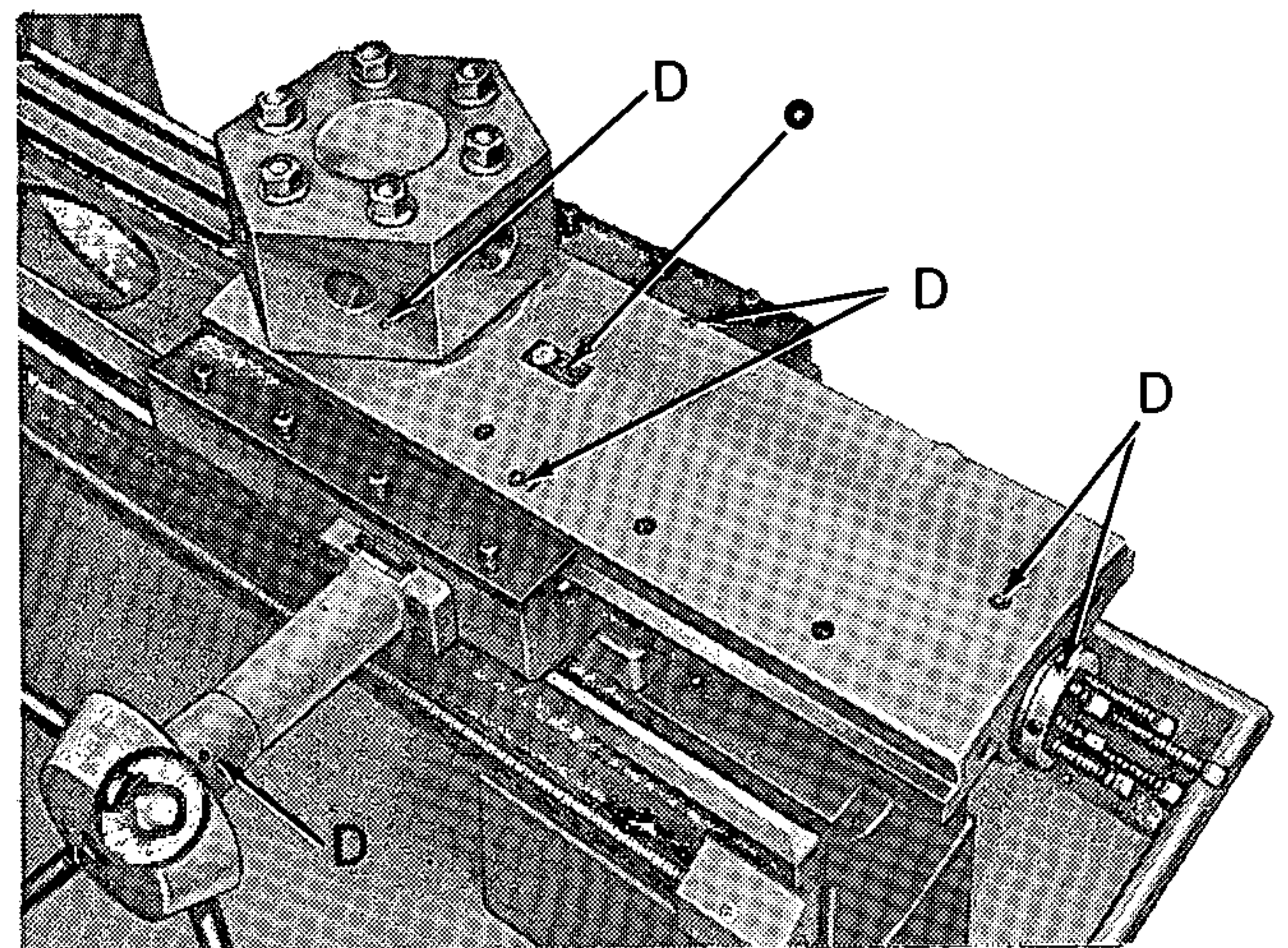

### ORDERING REPAIR PARTS

The following must be furnished when ordering parts in addition to quantity required.

- 1 PART NUMBER
- 2 PART NAME
- 3 MODEL & SERIAL NUMBER – on Plate attached to side of turret base – see illustration above.



**NOTE:** Screws and nuts shown without part numbers should be purchased locally.



# NO. 7228 & 7229 BED TURRETS PARTS LIST

