

CLAUSING 5900 SERIES LATHES

TRANSPOSING GEAR CHART FOR CUTTING
METRIC PITCH THREADS ON QUICK CHANGE
LATHE WITH ENGLISH LEAD SCREW

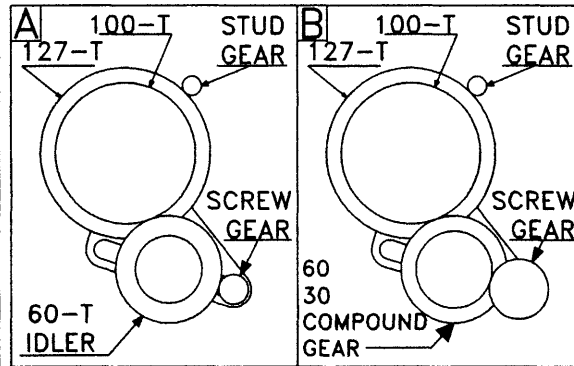

MM PITCH THREAD	STUD GEAR	A OR B	SCREW GEAR	SET GEAR BOX TO CUT
7.	28	A	20	5 THREADS
6.	24	A	25	4 "
5.5	22	A	25	4 "
5.	20	A	25	4 "
4.5	18	A	25	4 "
4.	18	A	25	4½ "
3.5	28	A	20	10 "
3.	18	A	25	6 "
2.5	20	A	25	8 "
2.	18	A	25	9 "
1.75	28	A	20	20 "
1.5	18	A	25	12 "
1.25	20	A	25	16 "
1.	18	A	25	18 "
.9	18	A	25	20 "
.8	16	A	25	20 "
.75	18	A	25	24 "
.70	28	A	50	20 "
.60	24	A	50	20 "
.50	16	A	50	16 "
.45	18	A	50	20 "
.40	16	A	50	20 "
.30	24	B	50	20 "
.25	16	B	50	16 "

DANCO PER 12-108