

OPERATING INSTRUCTIONS
and
PARTS LIST

10
CLAUSING

10-inch LATHES - 4900-series

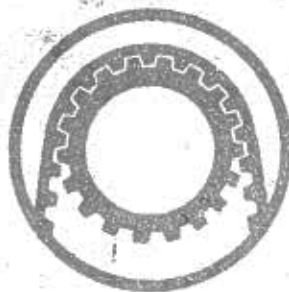

CLAUSING

1915-2023 N. PITCHER ST., KALAMAZOO, MICHIGAN - U. S. A.

This Manual Applies To Clausing 10" Lathes From Serial No. 403934 To _____

CONTENTS

INSTALLATION

Dimension Drawing	2.1
Foundation	3.1
Cleaning	3.1
Moving and Lifting	3.1
Electrical Connections	4.1
Anchoring	4.1
Leveling	4.1

LUBRICATION

Lubrication Chart	5.1
-----------------------------	-----

OPERATION

Functional Diagram	6
Back Gear Controls	7
Spindle Speeds	7
Headstock	8
Quick-Change Gear Box	8
Carriage	8 & 9
Tool Holders	10
Tailstock	11
Chucks and Face Plates	11

MAINTENANCE AND ADJUSTMENTS

Preventative Maintenance	12.1
Belts--replacing and tensioning	12.1
Carriage Bearing Plates	12.1
Gibs	12.1
Shear Pin	13
Spindle Bearings	13

PARTS INDEX & INSTRUCTIONS FOR ORDERING PARTS . . 14.10 - 28

ATTACHMENTS 29

GENERAL DIMENSIONS -- 4900 SERIES CLAUSING LATHES

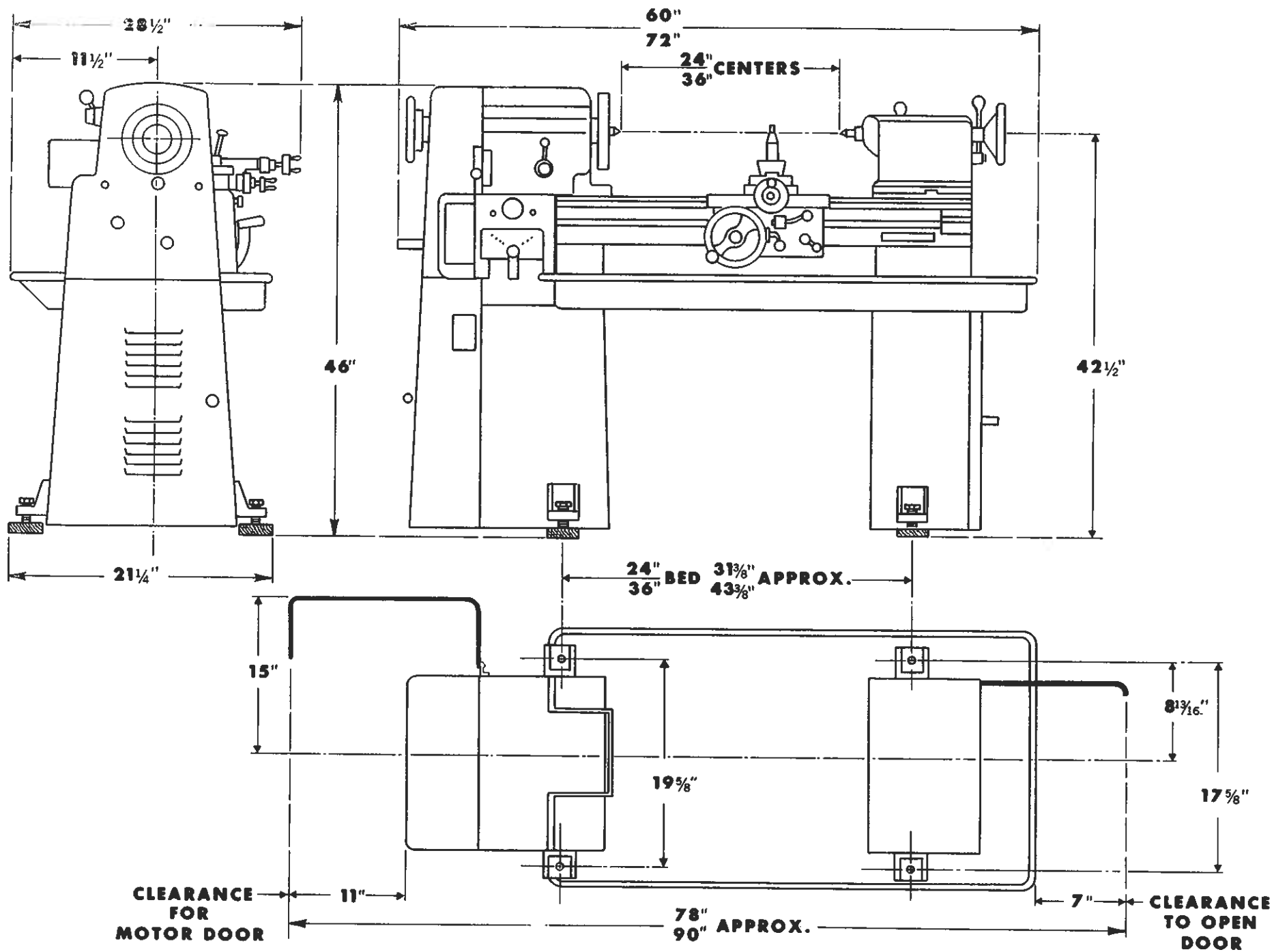

INSTRUCTIONS and PARTS



CLAUSING CORPORATION
KALAMAZOO, MICHIGAN 49001

WIRING INSTRUCTIONS

for

4900-series

Serial Numbers from 400971

5900-series

Serial Numbers from 500817

CLAUSING LATHES

DEC. 15, 1971 FILE NO. 710-041-2

REVERSING SWITCH for SINGLE PHASE (110 Volt) MOTORS

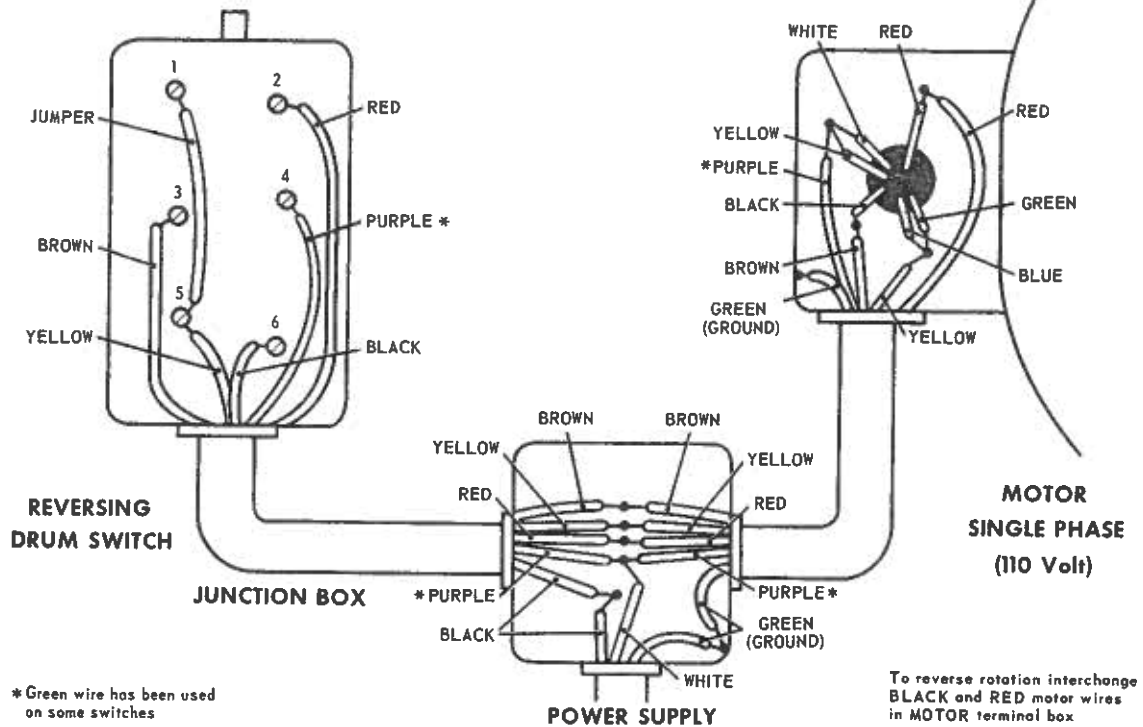

REVERSING SWITCH for SINGLE PHASE (220 Volt) MOTORS

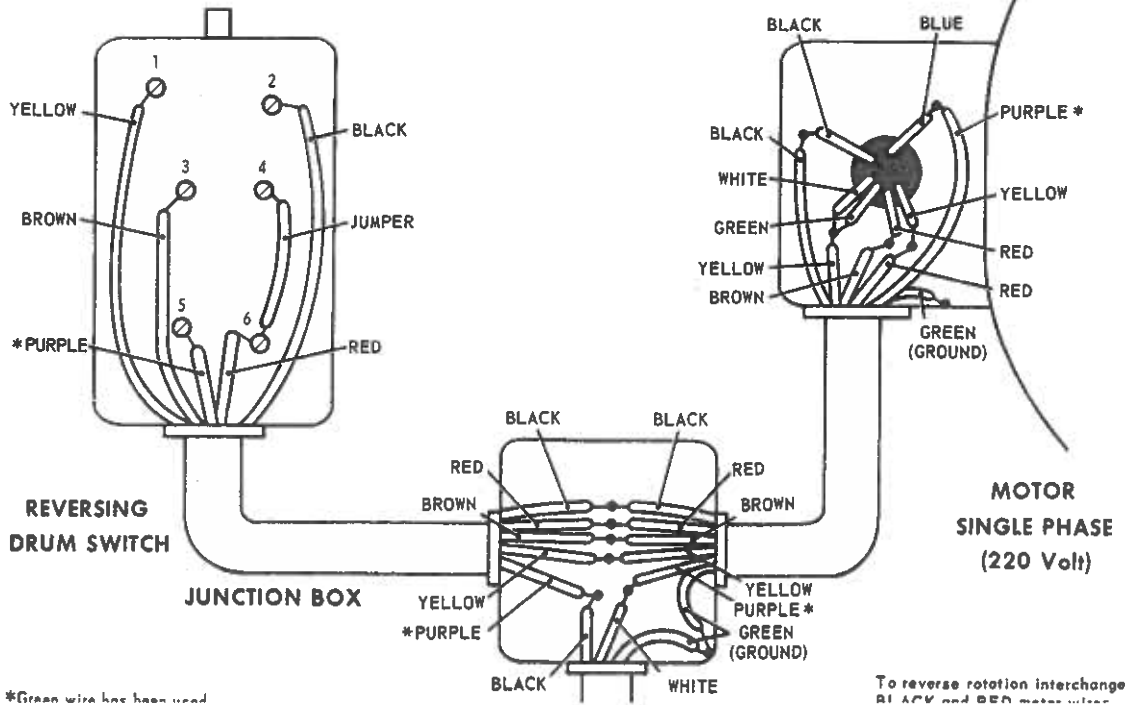

REVERSING SWITCH for 3-PHASE (220 Volt) MOTORS

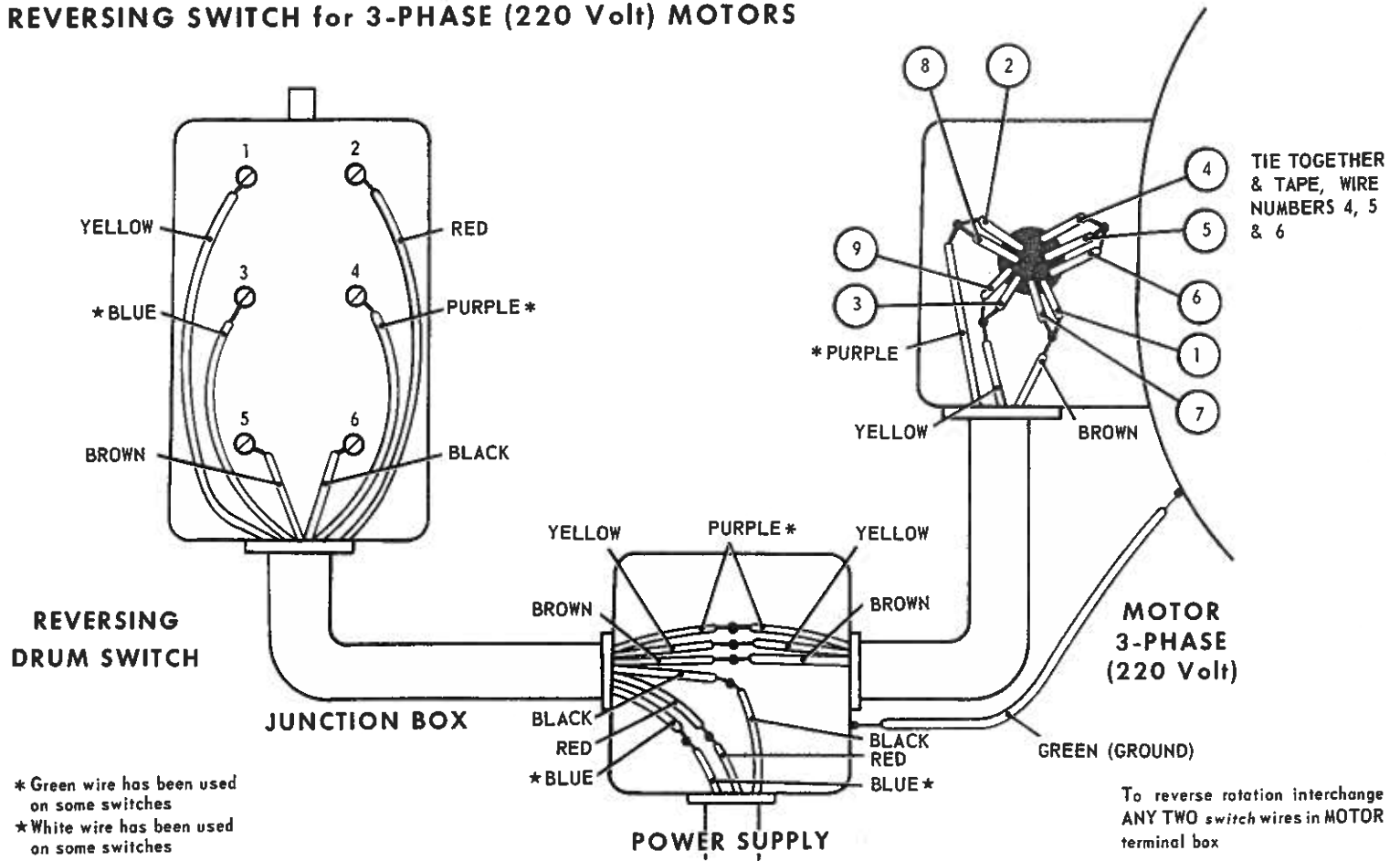

REVERSING SWITCH for 3-PHASE (440 Volt) MOTORS

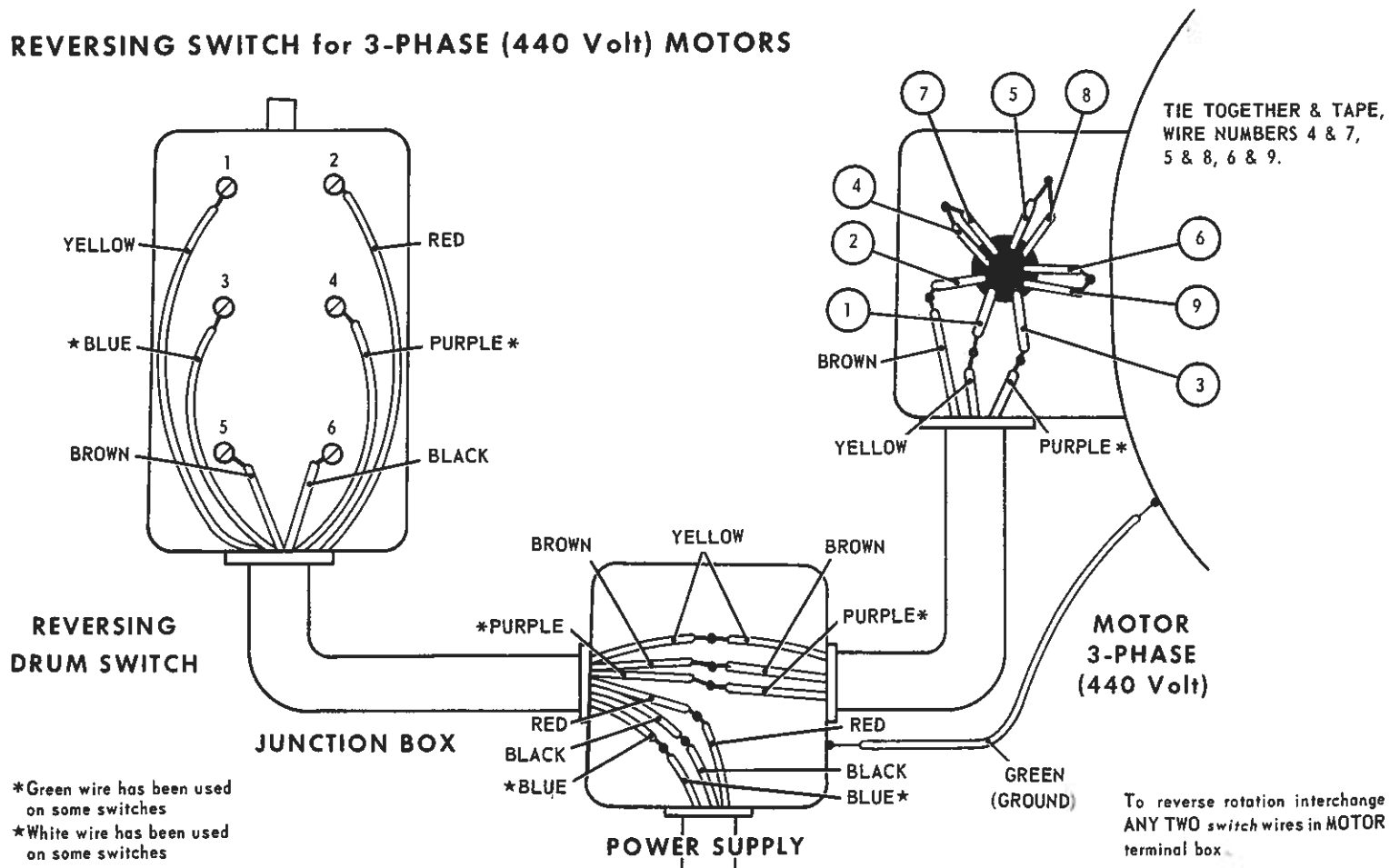

INSTRUCTIONS and PARTS



DIVISION, ATLAS PRESS COMPANY
KALAMAZOO, MICHIGAN 49001

130-025-10
THREADING CHART

for

4900 SERIES CLAUSING 10" LATHES

JUNE 1967

FILE 130-025-10

C	SLIDE GEAR IN			SLIDE GEAR OUT		
	B	C	A	B	C	A
1	4	8	16	32	64	128
	.0367	.0183	.0092	.0046	.0022	.0011
2	4 1/2	9	18	36	72	144
	.0326	.0163	.0081	.0041	.0020	.00094
3	5	10	20	40	80	160
	.0293	.0147	.0073	.0036	.0018	.00092
4	5 1/2	11	22	44	88	176
	.0267	.0134	.0066	.0033	.0017	.00083
5	5 3/4	11 1/2	23	46	92	184
	.0255	.0127	.0063	.0031	.0016	.00079
6	7	14	28	56	112	224
	.0209	.0105	.0052	.0026	.0013	.00065
7	6 3/4	13 1/2	27	54	108	216
	.0218	.0109	.0054	.0027	.00136	.00068
8	6 1/2	13	26	52	104	208
	.0226	.0113	.0056	.0028	.0014	.0007
9	6	12	24	48	96	192
	.0244	.0122	.0061	.003	.0015	.00076

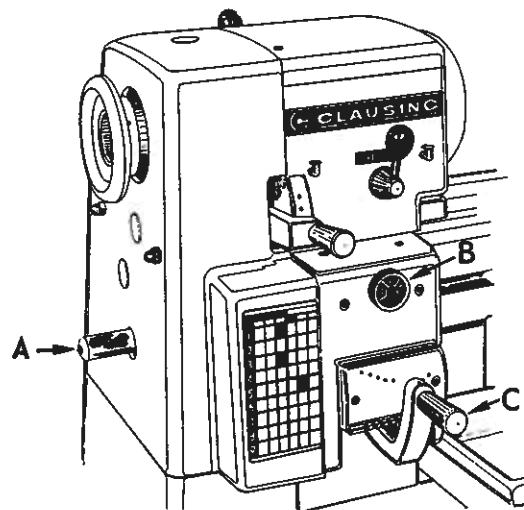

LEGEND

A. GEAR SHIFTER HANDLE changes ratio between spindle and lead screw. There are two positions IN and OUT. Do not shift while spindle is turning.

B. GEAR SHIFTER KNOB has three positions - B, C or A. Engaged position is vertical. If knob doesn't shift easily, place lead screw direction lever in neutral (center position) and turn sliding gear handle until knob can be engaged - do not force.

C. GEAR SHIFTER LEVER. To shift, pull out on handle, drop lever, slide to position desired, raise lever and push in handle to engage lock pin. If thread-feed selector handle does not slide easily, turn sliding gear shifter handle (A) while shifting.

CROSS FEED 1/4 OF LONGITUDINAL

INSTALLATION

FOUNDATION

Your Clausing lathe is a precision machine tool, and requires a solid foundation. The floor must be heavy enough to support the weight of the machine without noticeable deflection, and it must be level. If the floor does not meet these important requirements, a special foundation should be built.

CONCRETE FLOORS -- A reinforced concrete floor is the best foundation: it provides a rigid base, minimizes vibration from adjacent machines, and resists deflection.

WOOD FLOORS should be carefully checked for strength -- place a precision level on floor where lathe is to be located, and move a hand truck with average load past it. If bubble in level shows noticeable movement, the floor should be reinforced, or cut away and a concrete foundation installed.

CLEANING

Before moving carriage or tailstock along the ways, use a good grease solvent to remove the rust-proof coating applied to all polished and unpainted surfaces.

Do not use an air hose -- it could force dirt or grit picked up during transit into bearing surfaces.

Use a stiff bristle brush to clean lead screw.

When thoroughly cleaned, cover the unpainted surfaces with a light coating of "Way Lubricant" for proper lubrication.

Frequent cleaning and lubrication is essential to long service life -- see page 5 for instructions.

MOVING AND LIFTING

Leave lathe on skid -- simplifies moving to final location.

IMPORTANT: DO NOT slide lathe along floor.
DO NOT USE fork lift under chip pan.

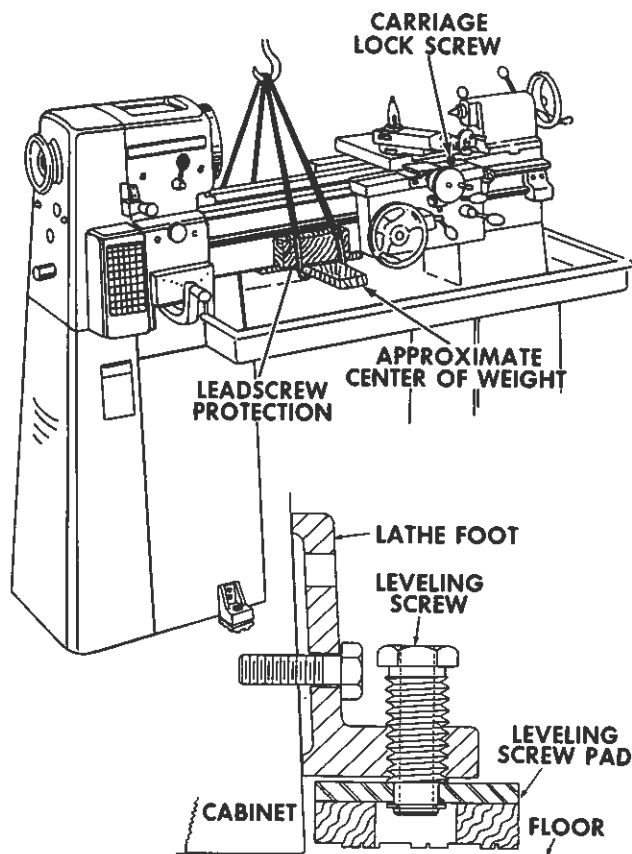

Figure 1

CAUTION: DO NOT LOWER LEVELING SCREW PADS UNTIL LATHE IS READY TO BE LEVELED -- refer to figure 1.

When using a sling -- clean bed ways, move tailstock to the right-hand end of the bed and lock it in place. To protect lead screw and bed, place a 3/4" thick hardwood board under approximate center of weight load, insert sling as shown in figure 1, and raise machine about one-inch off floor. Make any necessary adjustments for balance by moving carriage along bed. -- Before moving carriage, loosen lock screw -- located on top right side of the carriage.

If a fork lift is used, place 3/4" thick hardwood board under the bed so that the clutch rod will not be bent when the lathe is raised -- do not pick up by chip pan.

Mounting pads do not require anchoring.

Leveling screws are equipped with non-slip mounting pads which eliminate the need for anchoring or bolting machine to floor. Floor must be clean and free of oil.

ELECTRICAL CONNECTIONS

The machine is wired at factory -- merely connect power supply to line leads in junction box on back of headstock cabinet. **IMPORTANT:** To reverse rotation of motor interchange any two line leads -- see WIRING INSTRUCTIONS.

Before connecting motor, make sure that voltage and other current requirements of the motor correspond with your power supply. If there is any question, verify your current and voltage by calling your power company.

ANCHORING LATHE TO FLOOR

CAUTION: DO NOT SLIDE LATHE ALONG FLOOR.

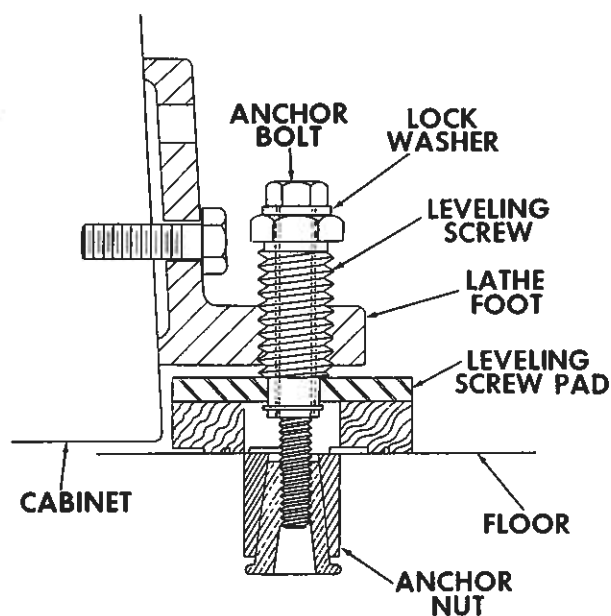

Figure 2

Use anchor bolts to secure lathe to concrete floor -- use lag screws to secure lathe to wood floor -- refer to figure 2.

With a hoist or lift, lower the lathe into position and mark the four leveling screw locations. **DO NOT LOWER LEVELING SCREW PADS.**

Lift machine out of the way, drill holes for anchor nuts and install anchor nuts -- for lag screws drill pilot holes.

Position and lower machine. Turn leveling screws until *no portion* of the lathe cabinet touches the floor -- shim under pads, if necessary.

Start anchor bolts or lag screws -- **DO NOT** tighten until lathe is level -- see Leveling Instructions.

LEVELING

The lathe should be kept perfectly level at all times. When carelessly mounted, the bed may become twisted. Even a slight amount of twist will move centers out of alignment and result in inaccurate work and excessive wear. Make it a habit to regularly check the level of the bed.

THIS IS IMPORTANT:

Use *one* precision level at least 6" long -- level should show a distinct bubble movement when a .003" shim is placed under one end.

Clean the bed ways thoroughly.

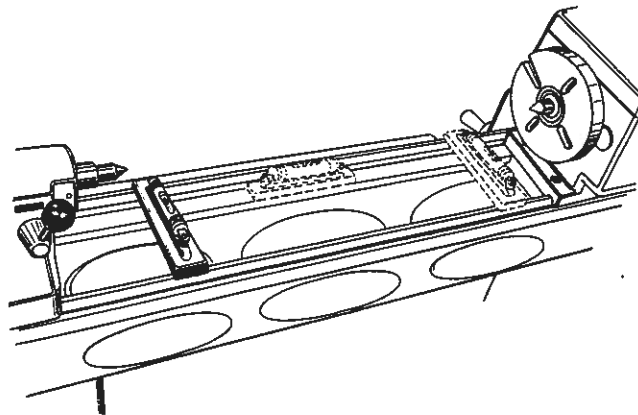

Figure 3

1. First level bed longitudinally, compensate for variations of bubble readings by turning the leveling screws on the cabinet base until bed is level -- refer to Figure 3 for level positions.

2. Next level both ends of the bed. The headstock and the tailstock -- must be checked with the level placed at right angles to the bed. Refer to Figure 3. Use a square to align the level. *Do not turn level end for end.*

Level reading at headstock and tailstock must be identical. Compensate for variations of bubble readings by turning the leveling screws until lathe is level.

NOTE: Avoid excessive adjustment of leveling screws by inserting shims between pads and floor.

3. Tighten the four anchoring bolts *not more than* finger-tight, or until the lock washers start to compress -- lag screws should be tightened, then backed off about one-quarter turn.

4. Recheck the level of the lathe -- unequal tightening of anchoring bolts may have pulled the bed out of level. Recheck leveling in 5 days.

Check level of bed at frequent intervals. Chatter -- turning taper -- boring taper -- facing convex or concave is the general result of an improperly leveled lathe.

LUBRICATION CHART - - - 4900 SERIES CLAUSING LATHES

CODE

- D1 - DAILY oil with SHELL TELLUS 27 oil or equivalent.
- D2 - DAILY oil with SHELL TONNA 33 or equivalent.
- W - WEEKLY oil with SHELL TONNA 33 or equivalent.
- M - MONTHLY clean with kerosene, then oil with SHELL TONNA 33 or equivalent.
- S - SEMI ANNUALLY lubricate quadrant gear teeth with SHELL ALVANIA 2 or equivalent. Remove oil and dirt before applying grease

- *Remove plug.
- ** Remove plug and turn spindle until oiler shows.
- ***Remove cover.

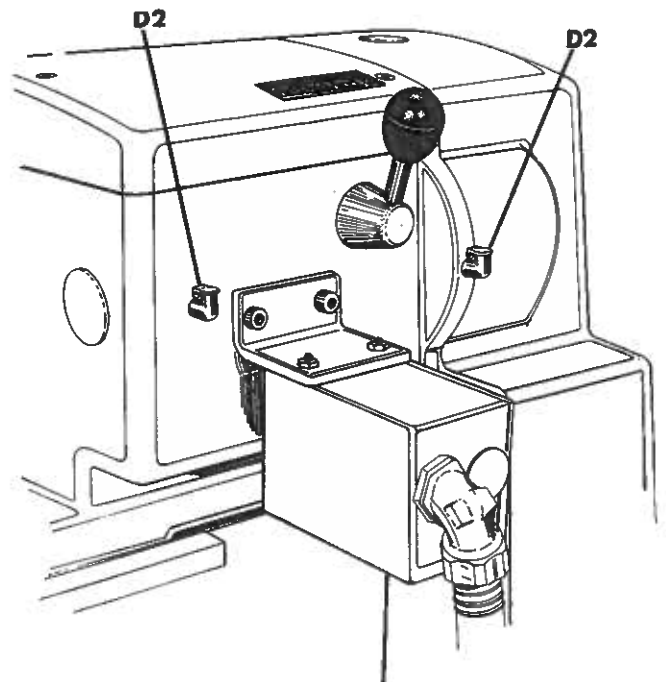
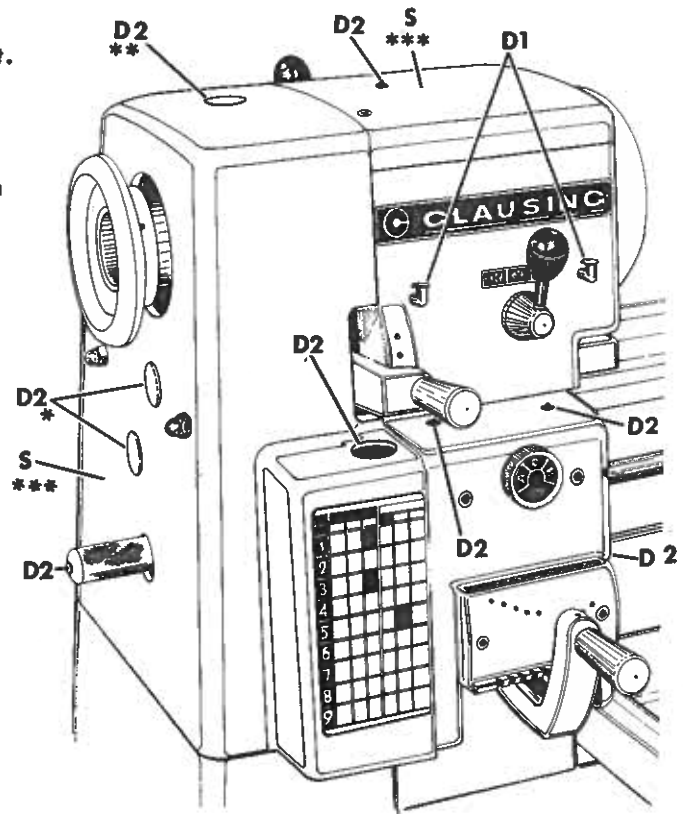
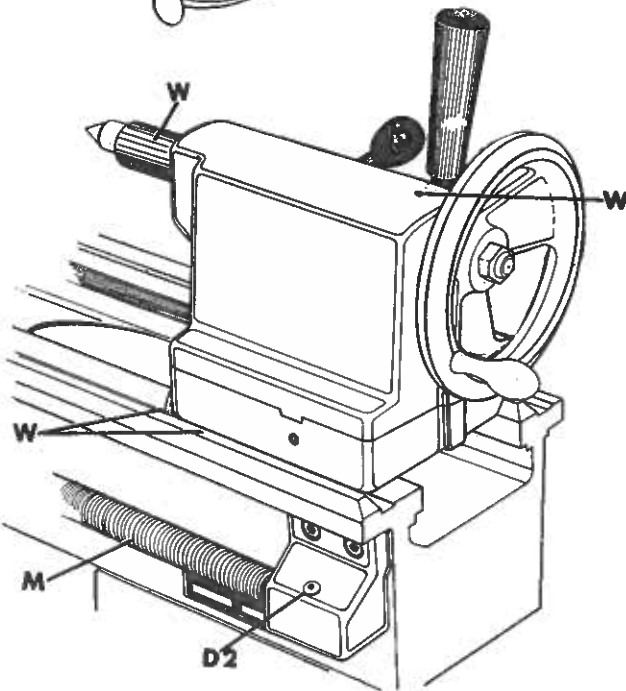
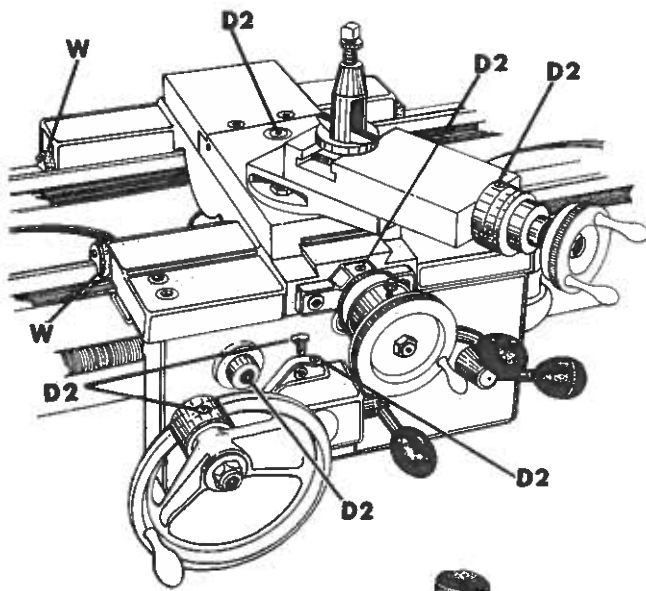

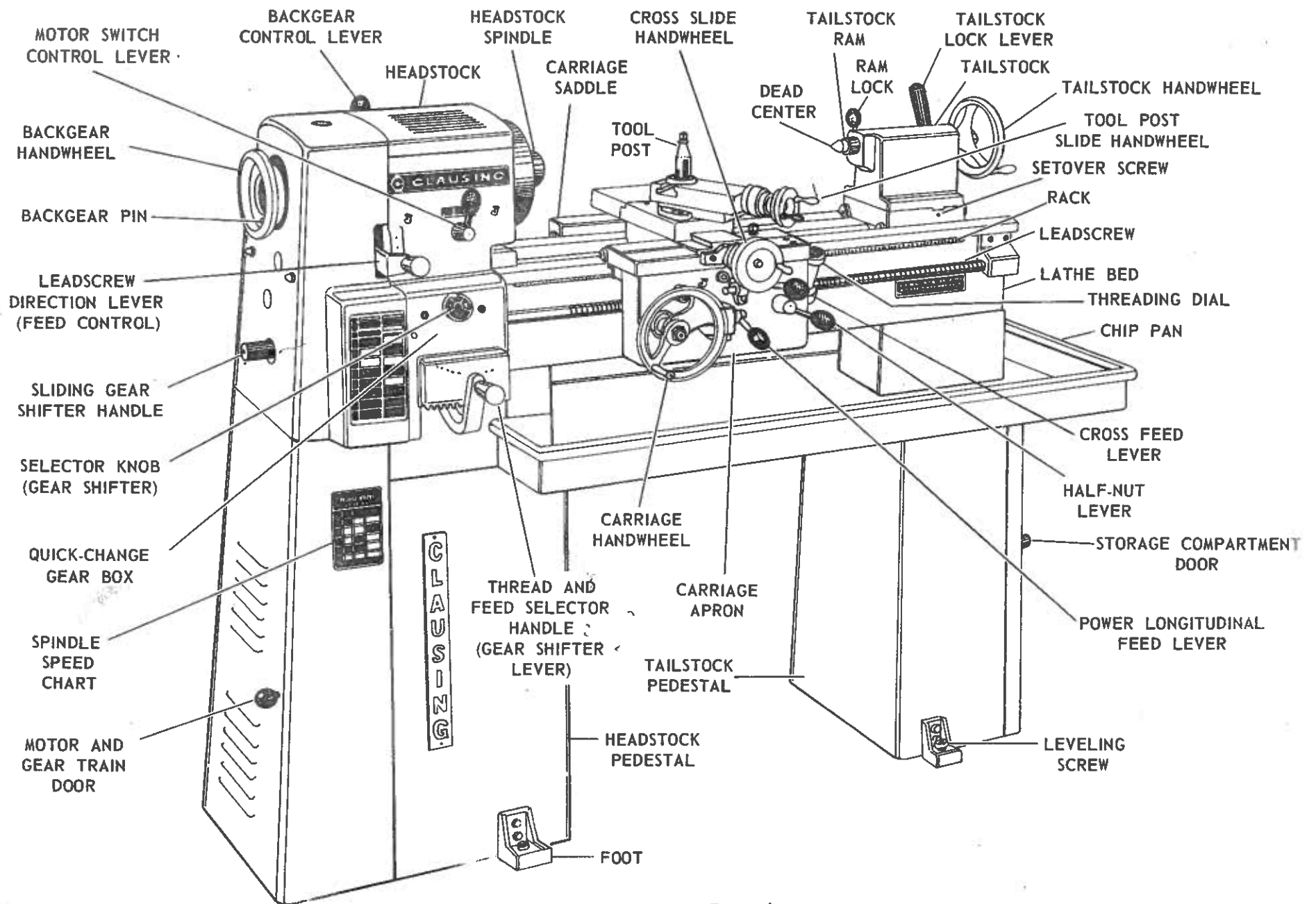

Figure 4

CONTROLS AND OPERATION

Do not operate the lathe until you are thoroughly familiar with all controls and their functions. Read the instructions carefully. Then, operate the lathe in back gear -- get the "feel" of the controls -- set up different threads and feeds -- engage the power feeds -- get acquainted with the lathe before you start a job -- it will save time and produce better work.

BACK GEAR CONTROLS

BACK GEAR DRIVE provides the slow spindle speeds from 52 to 237 rpm required for heavy cuts and correct surface speeds for large diameter work.

IMPORTANT SAFETY FEATURE: The back gear knob has a safety lock -- it cannot be moved from one position to another unless motor switch is in "OFF" position. Spindle must come to a complete stop before changing drives.

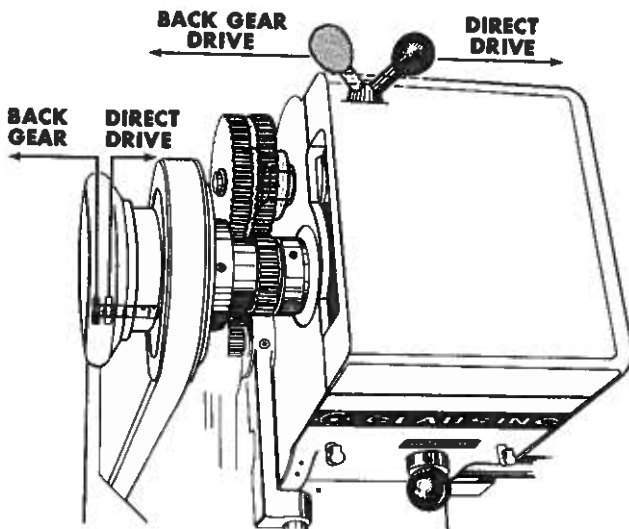

Figure 5

To engage the back gear drive:

1. Stop lathe spindle.
2. Disengage back gear pin (figure 5) from drive pulley by pulling pin away from headstock.
3. Move back gear lever to the left -- *Rotate spindle by hand if gears will not mesh.*

DIRECT DRIVE provides high spindle speeds from 370 to 1700 rpm.

To engage direct drive:

1. Move back gear lever to the right.
2. Engage the back gear pin with drive pulley by pushing pin towards headstock -- rotate wheel if necessary.

CHANGING SPINDLE SPEEDS

1. Move drum switch to stop position -- refer to figure 4.
2. Open motor compartment door on end of headstock cabinet.

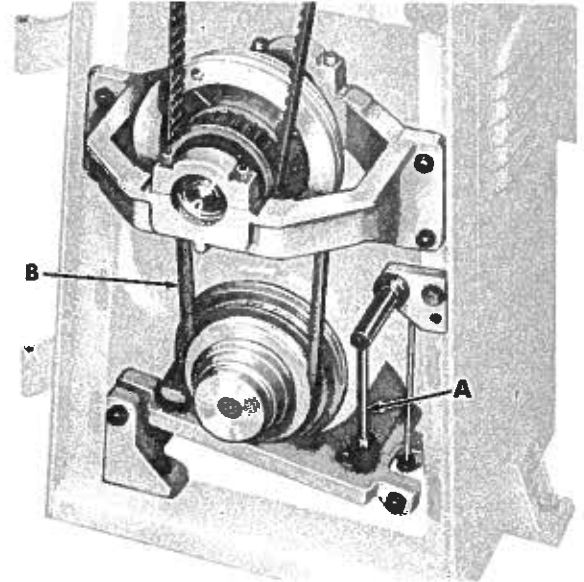

Figure 6

3. Raise belt tension lever (A, figure 6) to slacken belt (B).

SPINDLE SPEED IN R. P. M.		
	OPEN BELT	BACK GEAR
A	370	52
B	450	62
C	540	75
D	900	125
E	1250	174
F	1700	237
MOTOR 1800 R. P. M.		

Figure 7

4. Shift belt to position for speed desired, as indicated on Spindle Speed Chart -- figure 7.
5. Lower lever to re-tension belts.

HEADSTOCK

The headstock houses and supports the spindle, and driving gears which rotate the spindle. The spindle pulley is outboard for easy belt replacement.

Controls are described below:

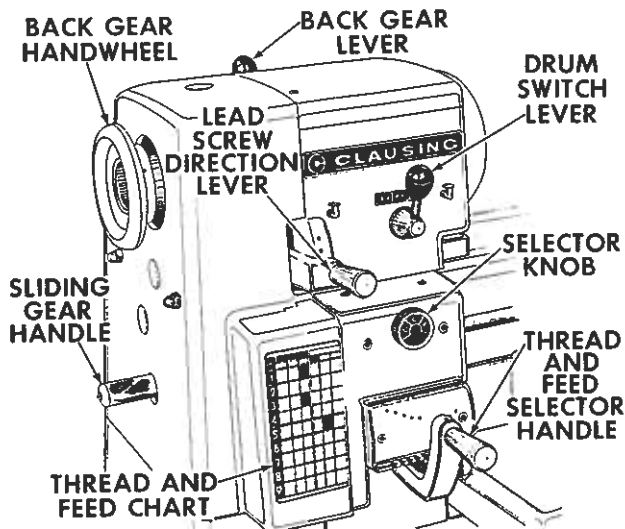

Figure 8

DRUM SWITCH LEVER located on front of headstock controls rotation of lathe spindle. It has three positions -- REVERSE, STOP, and FORWARD -- refer to figure 8.

NOTE: Control lever is equipped with a push-button-operated safety lock that prevents accidental reversing of spindle -- refer to figure 8.

To reverse rotation of motor and spindle:

1. Move lever to "OFF" position and allow spindle to stop.
2. Press and hold safety lock button while shifting to *opposite* rotation.

NOTE: The safety lock button is used *only* when reversing spindle rotation.

Caution: Always allow spindle to stop before reversing rotation.

LEAD SCREW DIRECTION LEVER is located on front of headstock. Lever has three positions. Center position is neutral -- gear train is disengaged, lead screw does not turn. Upper position moves carriage toward headstock. Lower position moves carriage toward tailstock.

Caution: Always stop lathe spindle before shifting lead screw direction lever.

QUICK-CHANGE GEAR BOX

The quick-change gear box, located on front of bed below the headstock, controls the rate of rotation of lead screw in relation to the rpm of the spindle for threading, and, for turning and facing operations.

The controls of the quick-change gear box are listed below -- their positions for thread or feed selected are shown on chart on front of box.

SLIDING GEAR HANDLE is located on end of headstock. Shifting the handle changes the ratio between the spindle and lead screw. There are two positions -- *IN* and *OUT* -- shift by pushing or pulling knurled handle.

THREAD AND FEED SELECTOR HANDLE is located on the lower front of gear box. To shift, pull on handle, drop lever, slide to position desired, raise lever and push in the handle to engage lock pin.

SELECTOR KNOB, located on front of gear box has three positions -- A, B, and C. Engaging position is vertical. If knob doesn't shift easily, place lead screw direction lever in neutral, and turn sliding gear handle until knob shifts into position -- *Do not force*.

CARRIAGE

The carriage, which is movable by hand or power along the bed, carries the cross slide, compound rest, tool post and cutting tool. The apron, anchored to front of carriage, contains the longitudinal feed mechanism, power feed clutch, power cross feed controls, and the thread-cutting half nut mechanism.

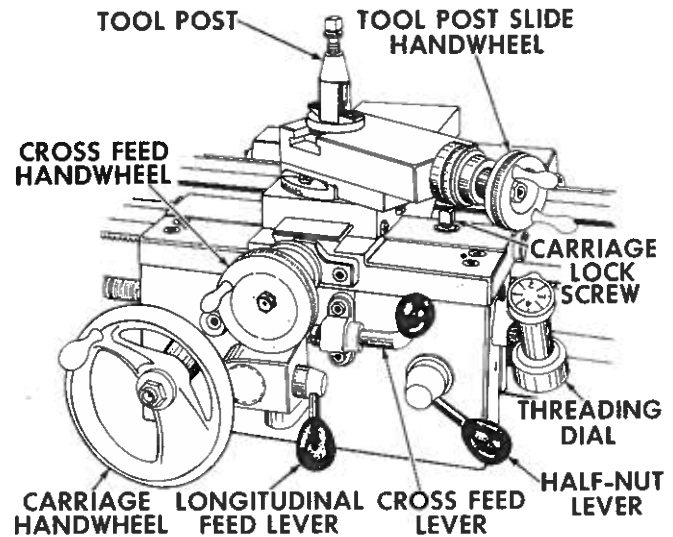

Figure 9

CARRIAGE HANDWHEEL moves carriage along the lathe bed manually -- refer to figure 9.

CROSS FEED AND TOOL POST SLIDE handwheels move the cross slide and tool post slide in and out.

CARRIAGE LOCK SCREW is used to lock the carriage to bed for facing or cut-off operations.

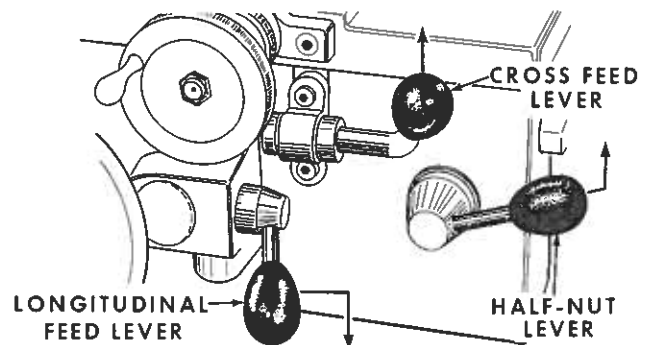

Figure 10

HALF-NUT LEVER engages half nuts with lead screw for threading -- refer to figure 10.

To engage half-nuts:

1. Move longitudinal feed lever to down position.
2. Move cross feed lever to up position.
3. Move half-nut lever to up position.

NOTE: Safety lock prevents engaging longitudinal feeds and half-nuts at same time -- *Do not force levers.*

IMPORTANT. Use half-nuts for thread cutting only -- never for feeds. It will prolong life of lead screw, and preserve its accuracy for threading operations.

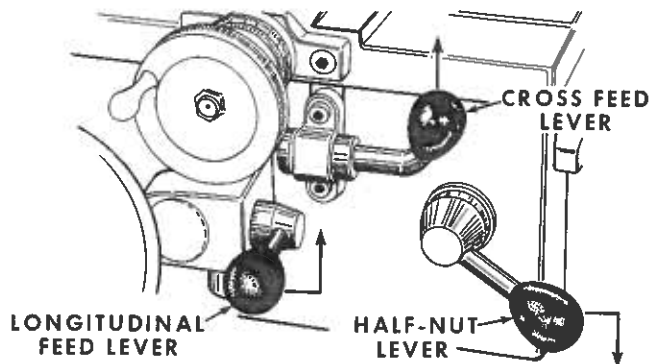

Figure 11

LONGITUDINAL FEED LEVER controls longitudinal travel of carriage -- refer to figure 11.

To engage power longitudinal feed:

1. Move half-nut lever to down (disengaged) position.
2. Move cross feed lever to up (disengaged) position.
3. Move longitudinal feed lever to up position.

NOTE: Safety lock prevents engaging longitudinal feeds and half-nuts at same time -- *Do not force levers.*

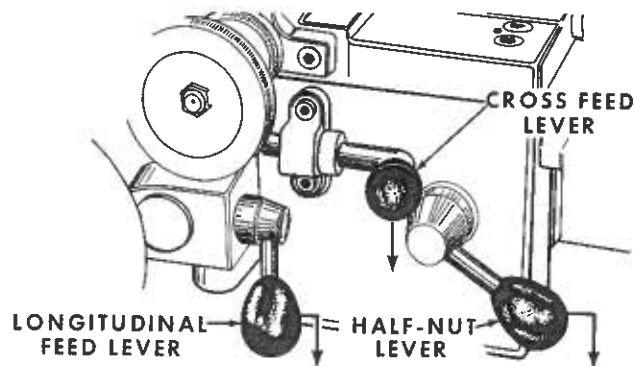

Figure 12

CROSS FEED LEVER controls power feed of cross slide -- refer to figure 12.

To engage power cross feed:

1. Move half-nut lever to down (disengaged) position.
2. Move longitudinal feed lever to down (disengaged) position.
3. Move cross feed lever to down position.

NOTE: Cross feed is 1/4 of the rate of longitudinal feed.

SEQUENCE OF ENGAGING CONTROLS FOR THREADS OR FEEDS

1. Select thread or feed from chart and position controls as indicated -- refer to figure 8.
2. Move THREAD-FEED SELECTOR HANDLE to the number position indicated.
3. Position SLIDING GEAR.
4. Position SELECTOR KNOB to A, B, or C as directed -- engaging position is vertical.
5. Shift LEAD SCREW DIRECTION LEVER for lead screw direction desired.
6. Position BACK GEAR LEVER and HANDWHEEL as indicated on chart.

THREADING DIAL

The threading dial performs the important function of indicating the proper time to engage the half-nut lever so the tool will enter the same groove of thread each successive cut. Without the threading dial, it would be necessary to wind the tool out of the thread at the end of each cut. Then, without disengaging half-nuts, reverse the rotation of the motor to bring the carriage back to the starting point for each successive cut.

The threading dial cannot be used for metric threads. For these, the half-nut is closed on the lead screw, and the machine reversed by means of the reversing switch. After each cut and tool withdrawal, the tool is brought back to starting point. The nut remains engaged until the thread is completed.

When cutting *even-numbered thread* (such as 12, 14, 16, 32, etc., per inch), engage the half-nut lever for the first cut when the stationary mark on the outside of the threading dial is in line with *any* of the marks on rotating portion of the dial. Any dial marking may be used for successive cuts.

When cutting *odd-numbered thread* (such as 7, 9, 11, 23, 27, etc., per inch), engage the half-nut lever for the first cut and all successive cuts when the stationary mark on the threading dial is in line with *any* of the numbered marks on the dial.

When cutting *half-numbered threads* (such as 4-1/2, 5-1/2, 6-1/2, 11-1/2, etc., per inch), engage the half-nut lever at the *same* number on the threading dial for *each* cut.

PROPER POSITION OF TOOL POST SLIDE

For maximum tool support, the front edge of the tool post slide should be positioned flush with the front end of the upper swivel.

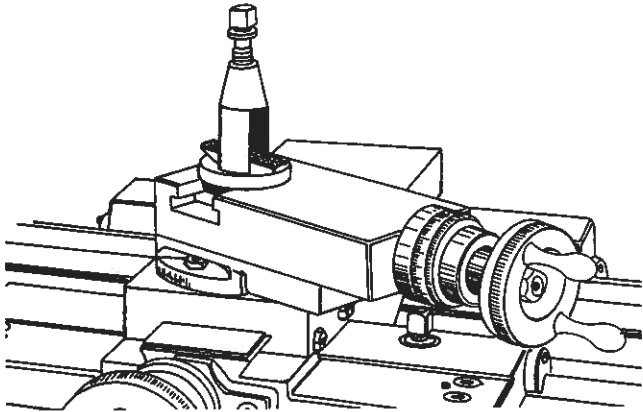

Figure 13

RIGHT -- Tool post slide is flush with front end of the upper swivel, therefore providing maximum tool support -- refer to figure 13.

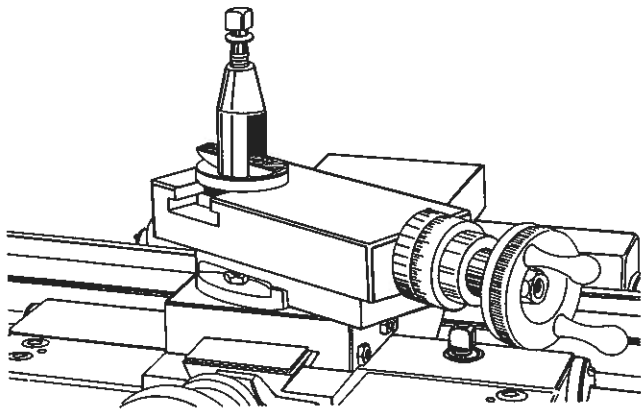

Figure 14

WRONG -- Unnecessary overhang of tool post slide will result in tool chatter, and could cause the tool post slide to break -- refer to figure 14.

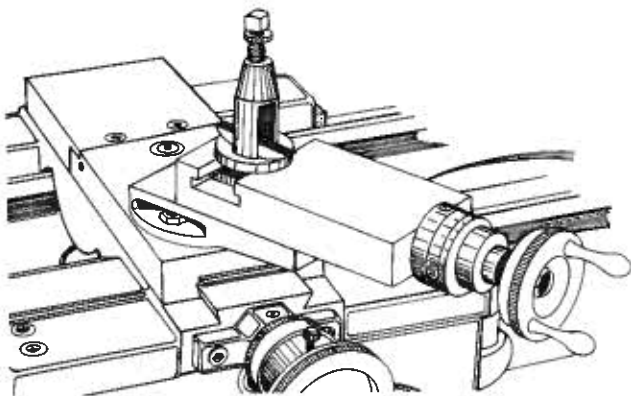

Figure 15

WRONG -- Tool post slide is too far back -- tool overhang is excessive -- refer to figure 15.

TOOL HOLDERS

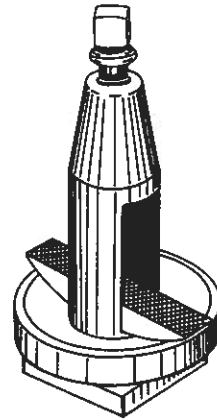

Figure 16

The tool post's job is to hold the tool rigidly in position for cutting operations -- refer to figure 16.

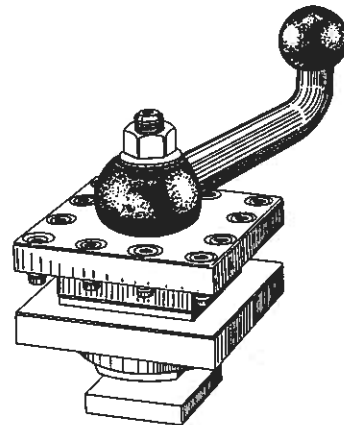

Figure 17

The 4-Way tool holder used in production work is shown in figure 17.

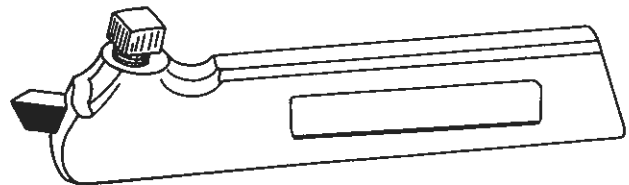

Figure 18

Universal tool bit holders permit the use of small, inexpensive and replaceable tool bits -- refer to figure 18.

In order to avoid undesirable overhang, tool bits should be clamped so the cutting end of the tool bit is as close to the holder as the work will permit, and, the tool holder should be as far back in the tool post as possible.

The cutting edge of the tool should be placed on lathe center line.

TAILSTOCK

The tailstock carries the "dead" center and is used to support the right-hand end of long pieces, and tools for drilling and reaming operations.

It consists of two main castings -- top and bottom.

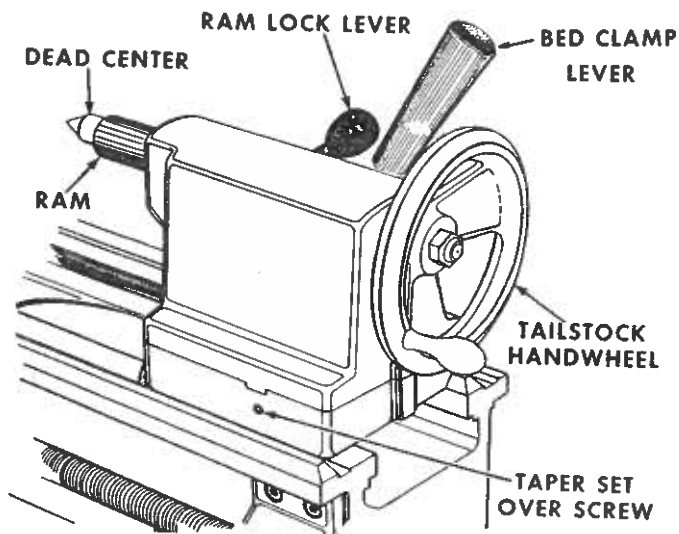

Figure 19

Top may be set over for taper turning by loosening the bed clamp and adjusting the screw on front and back of tailstock base -- refer to figure 19.

Base is fitted to bed ways to accurately align tailstock and headstock spindles. Tailstock slides along the ways, and may be anchored in any position by moving the clamping lever.

Ram is actuated by handwheel -- graduations on ram simplify drilling and boring. Ram is locked in place with the lock handle located on rear side of tailstock. Before inserting center or tools in ram, clean both tapers thoroughly with a clean, dry cloth.

MOUNTING CHUCKS AND FACE PLATES

1. Carefully wipe face of hub and threads clean of dirt and chips.
2. Carefully clean spindle threads and shoulder.
3. Cover spindle threads with a light film of clean oil. Nicks, burrs, chips, or dirt on the lathe spindle threads, pilot or shoulder -- or on the chuck pilot, threads or shoulder -- will throw the chuck out of alignment and result in inaccurate work.
4. Place lathe in back gear to keep spindle from turning.
5. Screw chuck or face plate on spindle -- do not force, it should thread on easily. Turn it rapidly as it nears spindle shoulder so hub will seat firmly against spindle shoulder face.

CAUTION -- Do not turn power on with the spindle locked.

TO REMOVE CHUCK OR FACE PLATE

1. Place board under chuck to protect bed ways, rotate chuck until wrench hole is on top. Lock spindle by engaging back gears. Place chuck wrench in chuck and pull. If chuck doesn't release, tap **BASE OF WRENCH** lightly with a mallet. Remove chuck carefully so as not to damage spindle threads. Disengage back gears.

2. To remove face plate, lock spindle by engaging back gears and tap slot in face plate with a lead or brass hammer in a counter clockwise direction. Remove face plate carefully to prevent damaging spindle threads. Disengage back gears.

CAUTION -- Never remove chuck or face plate while lathe is running.

CHUCK MAINTENANCE AND CARE

INSPECT YOUR CHUCK PERIODICALLY -- if used properly, a chuck will give good service for a long period.

OIL CHUCK FREQUENTLY -- Most wear is due to dirt and lack of proper lubrication. Oil chuck jaws and scroll at regular intervals with a light film of clean SAE No. 10 machine oil. **CAUTION:** Do not apply too much oil -- it collects dust and chips.

PROTECT CHUCK WHEN NOT IN USE -- Place chuck in a covered box -- don't leave it exposed to dirt or chips -- the accuracy of any chuck can be destroyed if dirt or chips collect in the scroll, threads, jaws or slots.

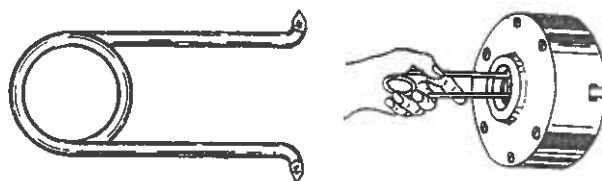

Figure 20

Use a tooth brush to clean spindle threads -- bent wire filed on ends to a V shape should be used to remove dirt and chips from chuck threads. -- refer to figure 20.

To maintain chuck accuracy, **NEVER** abuse your chuck.

IMPORTANT

KEEP YOUR LATHE CLEAN -- Oil and dirt form an abrasive compound which will damage bearing surfaces. Wipe the bed and all machined surfaces with a clean oily rag at frequent intervals. Use a brush to clean spindle, gear teeth, lead screw threads, etc.

MAINTENANCE AND ADJUSTMENTS

PREVENTIVE MAINTENANCE

The lathe should be kept clean and properly lubricated at all times.

Don't use your lathe for a work bench. Don't leave tools on bed ways.

Always shut off power before leaving lathe.

Recheck level of the bed frequently.

Lock tailstock to bed ways before turning between centers.

Before threading, clean chips and dirt from lead screw, and oil lightly.

Securely lock tool in position before taking a cut.

REPLACING TIMING BELT

1. With motor off, remove spindle handwheel, upper belt guard and open motor door.

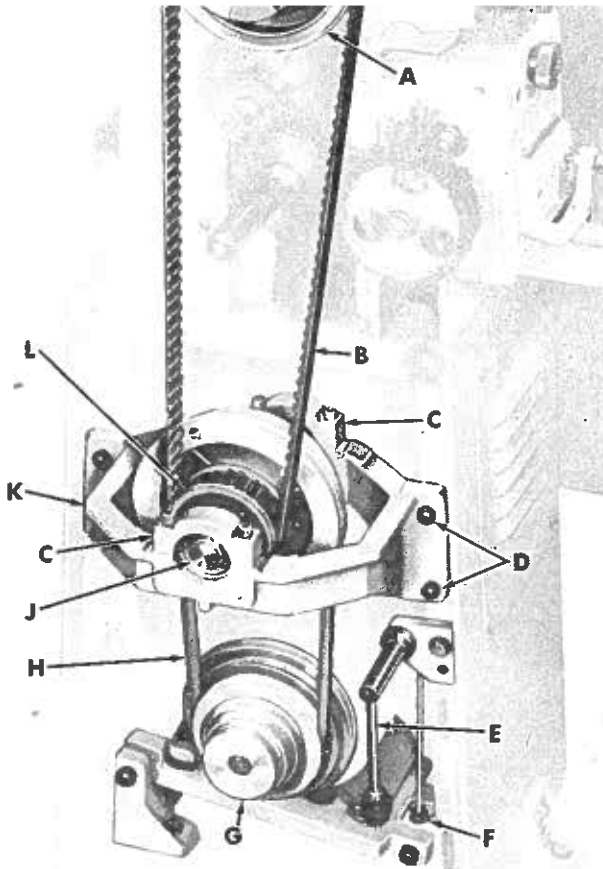

Figure 21

2. Raise belt tension lever (E, fig. 21).
3. Remove belt (H) from motor pulley (G).
4. Remove four hex nuts and countershaft (K) from mounting studs (D). Raise countershaft slightly and slip timing belt (B) off spindle pulley (A).
5. Place countershaft on bench.
6. Remove bearing caps (C), snap rings and countershaft spindle (J) from bracket (K).
7. Remove timing belt from countershaft pulley (L) and replace with new timing belt.

8. Install spindle in countershaft bracket and secure in place with snap rings and bearing caps (C). **IMPORTANT:** Make sure motor belt is in place before installing bearing caps.
9. Position countershaft so timing belt (B) can be slipped on spindle pulley (A).
10. Realign countershaft assembly on the four mounting studs (D), then tighten the four hex nuts.
11. Install and retension motor belt (H).
12. Install upper guard and spindle handwheel.

TENSIONING MOTOR BELT

1. Open motor guard.
2. With belt tension lever (E, fig. 21) engaged (down position), adjust nuts (F) until proper tension is obtained.

NOTE: Properly tensioned belt should depress approximately 1/2" with light finger pressure -- too much tension will cause excessive wear of bearings and shafts.

CARRIAGE BEARING PLATE ADJUSTMENT

Bearing plates on the carriage, which bear on the underside of both the front and back bed ways, anchor the carriage firmly to the bed in a vertical direction. Bearing plates have shims of varying thickness for adjustment of possible wear.

CROSS SLIDE AND TOOL POST SLIDE GIB ADJUSTMENT

Cross slide and tool post slide when properly adjusted should move with a slight drag.

To adjust cross slide and tool post slide gibs:

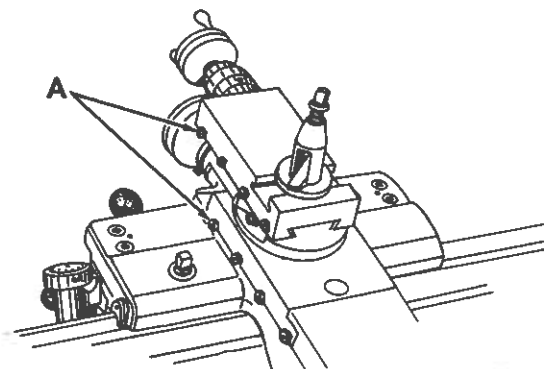

Figure 22

1. Loosen the gib screw lock nuts (A, fig. 22).
2. Adjust gib screws evenly until the slide moves with a slight drag.
3. Tighten the gib screw lock nuts -- hold gib screw with screw driver while tightening lock nuts.

REPLACING SHEAR PIN IN LEAD SCREW

Shear pin, located at gear box end of lead screw, protects lead screw and gear box against overload.

To replace broken shear pin:

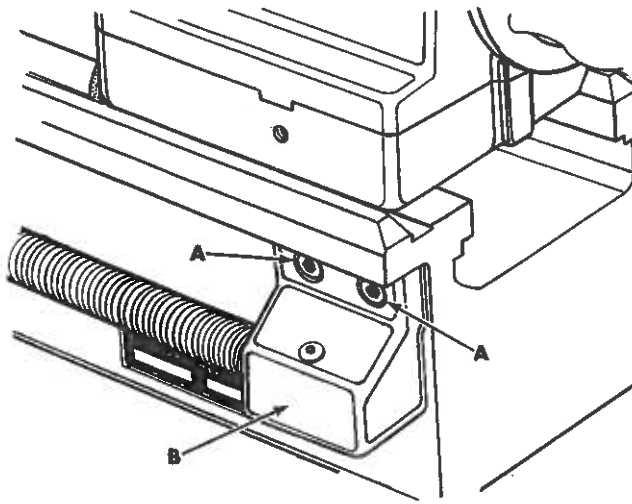

Figure 23

1. Remove two socket cap screws (A, fig. 23) from lead screw bracket (B) and remove bracket.
2. Engage half nuts, turn carriage handwheel toward tailstock, pulling lead screw from gear box shaft. Disengage half nuts and remove lead screw.

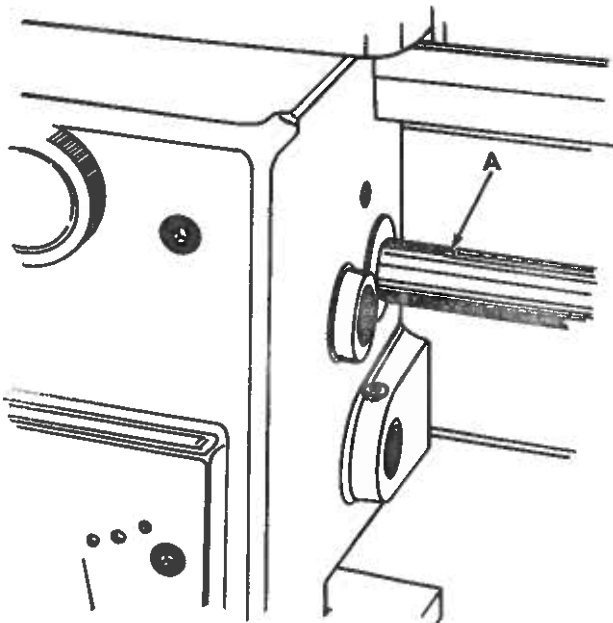

Figure 24

3. Remove sheared pin (A, fig. 24) from gear box shaft and lead screw.
4. Slide lead screw over gear box shaft -- check alignment of shear pin holes with punch -- turning lead screw 180° if necessary -- and install new shear pin with retainer.

5. Replace lead screw bracket -- CAUTION: Do not tighten the two socket cap screws.
6. Move carriage to tailstock end of bed, engage half nuts to align lead screw, then tighten the two socket cap screws.

ADJUSTING SPINDLE BEARINGS

Spindle bearings have been preloaded at factory and seldom require adjusting. Follow these instructions should adjustment be necessary:

1. Make adjustment only when spindle is at operating temperature -- run spindle at medium speed for one hour with 6" driving plate mounted on spindle.
2. Disengage back gear pin from drive pulley by pulling pin away from headstock.
3. Turn back gear knob to the right.
4. Move lead screw direction knob to vertical (NEUTRAL) position.
5. Give driving plate a sharp spin with your hand.
NOTE: If preload is correct -- drive plate should rotate about one turn.

To adjust:

1. Remove spindle handwheel and upper belt guard.

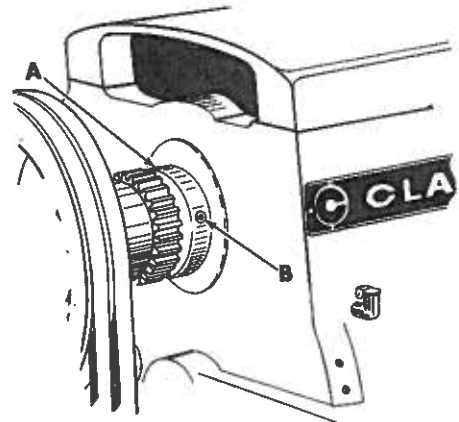

Figure 25

2. Loosen set screw (B, fig. 25) in bearing adjusting nut (A) and tighten nut with spanner wrench until spindle end play has been eliminated.
3. Give driving plate a sharp spin with your hand -- drive plate should rotate about one turn. If it doesn't, adjust nut (A) and recheck.
4. Tighten set screw (B) in adjusting nut.
5. Replace guard and handwheel.