

INSTALLATION,
OPERATION, MAINTENANCE

AND

PARTS LIST MANUAL

FOR

CINCINNATI TRAY-TOP
MODEL LE

10", 12-1/2", 15", 18"

ENGINE AND TOOLROOM LATHES

AND

CINCINNATI TRAY-TOP
MODEL LE

15" & 18"

FIXED GAP BED LATHES

CINCINNATI LATHE AND TOOL CO.

CINCINNATI 9, OHIO, U.S.A.

FOREWORD

This Manual has been prepared for use with the 10", 12-1/2", 15" and 18" Cincinnati Tray-Top Model LE Engine and Toolroom Lathes, and 15" & 18" Cincinnati Tray-Top Fixed Gap Bed Lathes manufactured by Cincinnati Lathe and Tool Co., Cincinnati 9, Ohio, U.S.A.

Because of continual betterment of design, it is possible that data contained in this manual may not fully apply to the machine delivered to you. Any differences merely indicate that your machine incorporates improvements better to fulfill your requirements.

TABLE OF CONTENTS

Section		Page
I	DESCRIPTION	1
II	SPECIAL SERVICE TOOLS	4
III	OPERATION	4
IV	LUBRICATION	14
V	MAINTENANCE	15
VI	PARTS LIST	25

CINCINNATI LATHE AND TOOL CO.

CINCINNATI 9, OHIO, U.S.A

SECTION I
DESCRIPTION

1-1. The Tray-Top is basically a conventional, standard type of engine lathe, built by line assembly methods of completely tooled components, units and details, produced in quantities by organized manufacture.

1-2. It is used chiefly to perform those operations normally done on a lathe, such as turning, facing, boring and threading, on the surfaces of rotating work pieces, thereby producing shapes which are basically cylindrical in form.

1-3. The performance of these operations calls for certain functions which require the incorporation in the units comprising the lathe of certain structures and mechanisms.

1-4. The major functions and the units which provide for them are as follows:

Function	Unit
Transmit power to rotate the work piece.	Motor Drive (1) Headstock (4)
Hold or support the work piece.	Headstock (4), Tailstock (10), and upon occasion the Steady Rest and/or the Follow Rest
Provide control and various speeds of work rotation.	Headstock (4), Mechanical Control Assembly (16)
Hold the cutting tool in position.	Compound Rest (8) Cross Slide (6) Tool Post (7)
Provide for Hand and Power Movements (at various feed rates) of the cutting tool.	Carriage(5), Apron(18), End Gearing(11), Quick Change Box (12) and Leadscrew (15).
Provide Frame-work upon which these units are mounted and upon which they function.	Bed (14) Legs (13)

1-5. In addition, somewhat less important functions and their corresponding units are:

Function	Unit
Thread cutting.	Leadscrew (15), and Chasing Dial, and upon occasion, Depth Threading Stop
Collection of chips and upon occasion, supply and collection of cutting fluid.	Chip Pan (17), Motor Driven Pump and Piping
"Parking Places" for tools, small accessories, etc.	"Tray-Tops" on Headstock (3) and Tailstock (9)

1-6. GENERAL DESCRIPTION OF MAJOR UNITS.

1-7. MOTOR DRIVE. The Tray-Top Lathe is driven by a constant speed motor of requisite horsepower which is mounted on a pivoted motor plate located at the rear of the head end leg. Adjusting screws provide for the proper tension of the vee belts which transmit power from the motor pulley to the drive sheave on the input shaft to the headstock.

1-8. HEADSTOCK. The headstock unit consists of a cast iron housing into which is assembled the mechanism and gearing which transmits the power from the motor to the spindle in the form of controlled speeds. The spindle is provided with means for mounting centers, face plates, chucks or other suitable devices to hold and to drive the work piece. The headstock is securely positioned on the inner ways of the bed.

1-9. TAILSTOCK. The tailstock is mainly used to support the right end of a work piece when held between centers. It is occasionally used to support drills, etc. for operating on work pieces not supported on centers. This unit may be positioned longitudinally along the inner ways of the bed.

1-10. CARRIAGE - APRON. The carriage is supported on the outer vee and flatway of the bed and can be moved manually or by power along the bed. Suspended from the front of the carriage is the apron which contains the mechanisms and gearing driven from the splined leadscrew that provide power feed to the carriage and the cross slide. Mounted upon the carriage is the cross slide, compound rest and toolpost. The complete unit provides the mechanism for positioning the cutting tool and controlling and directing its manual or power movements.

1-11. QUICK CHANGE GEAR BOX. The quick change gear box is a unit located on the left front face of the bed directly below the headstock. It is driven from the headstock spindle by the end gearing. This mechanism controls the rate of rotation of the splined leadscrew in relation to that of the headstock spindle which drives the work piece, thereby providing the various feed rates and lead changes for thread chasing.

The spline provides the drive for power feeds to the carriage and cross slide. The threads of the lead-screw provide the drive to the carriage for thread chasing only.

1-13. BED - LEGS. The lathe bed is made of close grain cast iron. It supports the functioning units and provides accurate guideways for those that move on it. The structural stability of the bed is accomplished by cross girths which are placed at close intervals. The bed is supported at the headstock end by a cabinet type leg.

1-12. LEADSCREW. The leadscrew is located along the front of the bed and transmits power from the quick change gear box to the apron-carriage unit.

GENERAL SPECIFICATIONS, CINCINNATI TRAY-TOP LATHES
Model LE
10", 12 1/2", 15" and 18" sizes

	10"	12 1/2"	15"	18"
CAPACITY				
Swing over bed (inches)	10-3/4	13-1/4	15-3/4	18-3/4
Swing over cross slide (inches)	6-7/8	9	9-3/4	11-7/8
Distance between centers (Maximum turning length) (inches)	24 to 36	24 to 60	30 to 114	30 to 114
Motor -- standard (H.P.)	1	1 1/2	3	3
Motor -- high spindle speed range (H.P.)	1-1/2	2	3	3
HEADSTOCK				
Area of tray top (sq. inch)	160	160	185	185
Spindle speeds (number)	12	12	12	12
Spindle speed range (standard) (40 to 1 ratio) rpm	35 to 1200	35 to 1200	25 to 980	25 to 980
Spindle speed range -- high rpm	53 to 1800	53 to 1800	37 to 1470	37 to 1470
Spindle reverse	Electrical	Electrical	Electrical	Electrical
Spindle nose -- standard long taper key drive.	L-00	L-0	L-0	L-1
Spindle -- diameter of hole through (inches).	1-11/32	1-9/16	1-9/16	1-13/16
Spindle -- number of bearings	2 Taper Roller 1 Ball	2 Taper Roller 1 Ball	2 Taper Roller 1 Ball	2 Taper Roller 1 Ball
Spindle -- size of center	#2 Morse	#3 Morse	#3 Morse	#4 Morse
Headstock -- base length on bed (inches)	19-3/8	19-3/8	22-5/8	22-5/8
THREAD AND FEED RANGE				
Number of thread and feed changes.	48	48	48	48
Range of threads per inch	3 to 184	3 to 184	1-1/2 to 92	1-1/2 to 92
Range of feeds -- carriage (inches per turn of spindle).0020 to .1224	.0020 to .1224	.0019 to .1215	.0019 to .1215
Range of feeds -- cross slide (inches per turn of spindle).0005 to .0310	.0005 to .0310	.0009 to .0578	.0009 to .0578
Leadscrew (Acme) (diameter inches and threads per inch)	1-1/8 - 8	1-1/8 - 8	1-3/8 - 6	1-3/8 - 6
Range of metric leads with (2) conversion gears, mm.1875 to 11.5	.1875 to 11.5	.375 to 23	.375 to 23
Range of feeds -- carriage (mm per turn of spindle)0690 to 4.2260	.0690 to 4.2260	.0683 to 4.1912	.0683 to 4.1912
Range of feeds -- cross slide (mm per turn of spindle)0175 to 1.1200	.0175 to 1.1200	.0325 to 1.9975	.0325 to 1.9975

	10"	12 1/2"	15"	18"
CARRIAGE AND COMPOUND REST				
Cross slide travel (inches)	8-5/8	9	11	12
Top slide travel (inches).	2-1/2	2-1/2	3-3/8	3-3/8
Solid tool size (inches).	3/8 x 3/4	1/2 x 1	5/8 x 1-1/4	5/8 x 1-1/4
Tool holders -- size of tool shank (inches).	3/8 x 7/8 (#0)	1/2 x 1-1/8 (#1)	5/8 x 1-3/8 (#2)	5/8 x 1-3/8 (#2)
Carriage bearing on ways (inches).	18-1/4	18-1/4	22-3/8	22-3/8
Width of bridge (inches)	4-3/4	4-3/4	6	6
TAILSTOCK				
Area of tray top (sq. in.)	40	55	75	80
Spindle travel (inches).	4-1/2	4-1/2	6	6
Spindle diameter (inches).	1-1/2	1-1/2	2-1/4	2-1/4
Spindle -- size of center	#2 Morse	#3 Morse	#3 Morse	#4 Morse
Tailstock body -- length on bed (inches)	7-7/8	8-7/8	10-3/4	11-5/8
Tailstock set-over (either side of center) (inches)	1/2	1/2	1	1
TAPER ATTACHMENT				
Maximum (inches) taper per foot	3-1/2	3-1/2	4	4
Turns at one setting (inches)	12	12	16	16
MISCELLANEOUS				
Face plate -- large and small (diameters) (inches)	9-1/2 7	12 7	14-1/2 9	17-1/2 9
Steady rest standard capacity min. and max. dia., inches	1/4 to 3-1/2	1/4 to 3-1/2	1/2 to 5	1/2 to 5
Steady rest oversize capacity min. and max. dia., inches	3 to 6	3 to 6	4-1/2 to 7-1/2	4-1/2 to 7-1/2
Follow rest capacity -- (min. and max. diameter), inches	1/4 to 2	1/4 to 2	1/2 to 2-1/2	1/2 to 2-1/2
DRIVE--MOTOR				
Motor -- standard (H.P.)	1	1-1/2	3	3
Motor -- high spindle speed range (Extra cost) (H.P.).	1-1/2	2	3	3
Number of Vee belts	2	2	3	3
Pulley size -- Headstock (inches).	6-5/8	6-5/8	8-7/16	8-7/16
Pulley speed -- Headstock rpm (std.)	765	765	615	615
Pulley speed -- Headstock rpm (high)	1150	1150	923	923
SHIPPING DATA - EXCEPT FIXED GAP BED LATHES				
Basic machine size (inches)	10 x 24	12-1/2 x 24	15 x 30	18 x 30
Net weight, lbs. approx.	1655	1795	2690	2885
Add for each 6" extra of bed, lbs. approx.	25	30	45	50
Weight -- domestic shipment, lbs. approx.	2250	2400	3365	3585
Add for each 6" extra of bed, lbs. approx.	60	65	75	90
Weight -- boxed for export, lbs. . . approx.	2710	2850	3970	4205
Add for each 6" extra of bed, lbs. approx.	125	130	145	160
SHIPPING DATA -- FIXED GAP BED LATHES				
Basic machine size, inches			15 x 36	18 x 36
Weight net, lbs. approx.			2915	3135
Add for each 12" extra of bed, lbs. approx.			90	100
Weight -- domestic shipment, lbs. approx.			3655	3910
Add for each 12" extra of bed, lbs. approx.			150	180

	10"	12-1/2"	15"	18"
SHIPPING DATA - FIXED BED GAP LATHES (cont'd)				
Boxed for export, lbs. approx.			4400	4670
Add for each 12" extra of bed, lbs. approx.			290	320

The Cincinnati Tray-Top Lathe with Fixed Gap Bed, available in 15" and 18" nominal swing sizes, provides the following increased capacity.

	Nominal Swing	
	15"	18"
Swing over gap, inches	22	27
Approximate distance end of spindle nose to end of gap, inches	9-3/4	11-9/16
Gap face plate available, diameter, inches	21	25-1/2
Distance between centers (maximum turning length), inches	36 to 108	36 to 108

SECTION II

SPECIAL SERVICE TOOLS

2-1. There are no special tools required for servicing and overhauling these machines.

2-2. Standard tools furnished with the 10 in. and 12-1/2 in. machines are as follows:

Wrench - Williams adjustable hook spanner #474 (2 to 4-3/4 in. dia. capacity), our Part #602943

Wrench - Hexagon Box for Tailstock (1-1/16 in. across flats), our Part #600968

Wrench - Tool Post (9/16 in. square box and 11/16 in. open end), our Part #602946

2-3. Standard tools furnished with the 15 in. and 18 in. machines are as follows:

Wrench - Williams adjustable hook spanner #474-A (4-1/2 to 6-1/4 in. dia. capacity), our Part #602357

Wrench - Hexagon Box for Tailstock (1-1/4 in.

across flats), our Part #600967

Wrench - Tool Post (5/8 in. square box and 7/8 in. open end), our Part #601345

2-4. Wrenches needed but not furnished:

Wrench - Male Socket - Allen	-	3/32 in.
" " " "	-	1/8 in.
" " " "	-	5/32 in.
" " " "	-	3/16 in.
" " " "	-	7/32 in.
" " " "	-	5/16 in.
" " " "	-	3/8 in.

2-5. Also required:

Standard Type Screw Driver - 1/16 in. thick x 5/16 in. wide blade

Bent Scratch Awl (for clutch driven machines)

Adjustable Face Spanner - 3 in. size (J.H. Williams Co. No. 483)

SECTION III

OPERATION

3-1. PREPARATION FOR USE.

3-2. SELECTING LOCATION FOR MACHINE.

3-3. For best results from any machine, which depend to a great extent on the skill of the operator, it is important that the zone selected for its erection be well-lighted, as dry as possible, and as free as possible from vibration.

3-4. The machine should be located so that adequate space is provided for utilization of maximum ranges, as well as the space required for making adjustments. A minimum of 18 in. clearance space should be provided at the ends and rear of the lathe and at least 36 in. at the front for the operator.

NOTE

For important dimensions, see figures 3-1 and 3-2.

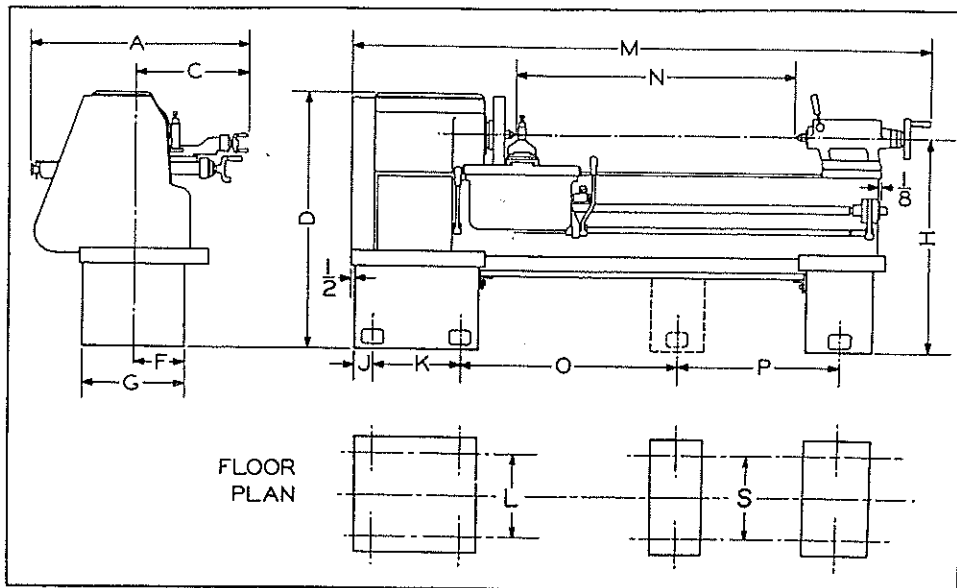

Figure 3-1. Cincinnati Tray-Top Lathe,
10", 12-1/2", 15" and 18"
Engine and Toolroom Models.

GENERAL DIMENSIONS, CINCINNATI TRAY-TOP LATHES,
10", 12-1/2", 15" and 18" SWING SIZES, ENGINE AND TOOLROOM MODELS

LATHE SIZE	Dimensions - in Inches									
	A	C	D	F	G	H	J	K	L	S
10"	34-1/4	18-3/8	51-1/8	7-11/16	15-3/8	44-1/8	3-3/4	15-1/4	12-5/8	7-1/8
12-1/2"	35-5/16	19	50-5/8	8-1/8	16-1/4	43-5/8	3-3/4	15-1/4	13-1/2	8
15"	43-1/4	22	51-3/8	9-3/8	18-3/4	43	3-3/4	17-3/8	16	10-3/4
18"	46-1/2	24	51-1/4	10-5/8	21-1/4	42-1/2	3-3/4	17-3/8	18-1/2	13-1/4

10" Lathe		
Actual turning distance	24	36
Center Distance (N) (With L-00 Nose Only)	28-17/32	40-17/32
M	75-1/8	87-1/8
O (approx.)	42	54

12-1/2" Lathe				
Actual turning distance	24	36	48	60
Center Distance (N) (With L-0 Nose Only)	26-3/4	38-3/4	50-3/4	62-3/4
M	74-7/8	86-7/8	98-7/8	110-7/8
O (approx.)	42	54	66	78

15" Lathe							
Actual turning distance	30	42	54	72	84	96	114
Center Distance (N) (With L-0 Nose Only)	34	46	58	76	88	100	118
M	90	102	114	132	144	156	174
O (approx.)	52-3/4	64-3/4	76-3/4	45	51	57	66
P (approx.)				50	56	62	71

18" Lathe				
Actual turning distance	30	42	54	72
Center Distance (N) (With L-1 Nose Only)	31-11/16	43-11/16	55-11/16	73-11/16
M	90	102	114	132
O (approx.)	52-3/4	64-3/4	76-3/4	45
P (approx.)				50

Actual turning distance	84	96	114	
Center Distance (N)				
(With L-1 Nose Only)	85-11/16	97-11/16	115-11/16	
M	144	156	174	
O (approx.)	51	57	66	
P (approx.)	56	62	71	

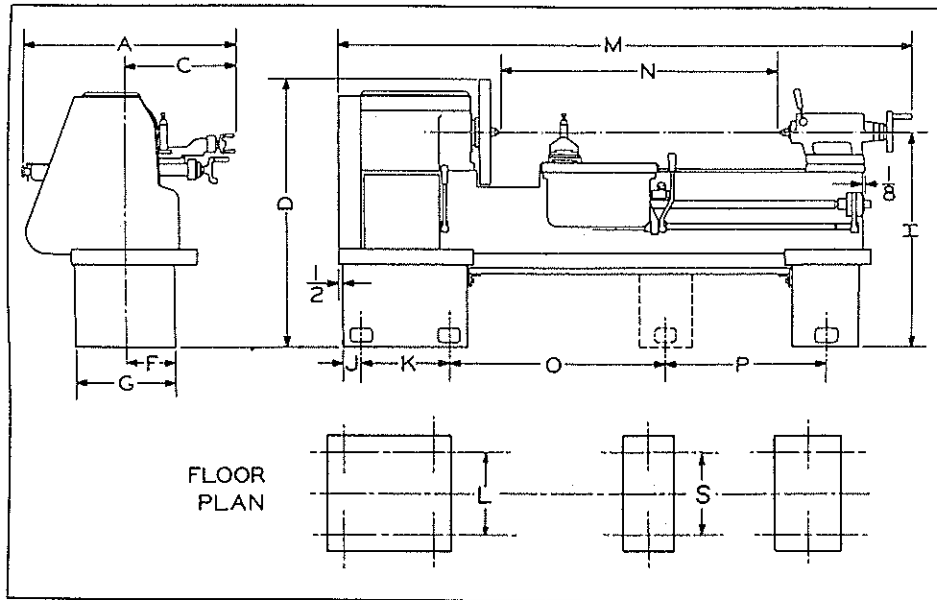

Figure 3-2. Cincinnati Tray-Top Lathe,
15" and 18" Fixed Gap Bed Models.

GENERAL DIMENSIONS, CINCINNATI TRAY-TOP LATHES,
15" and 18" FIXED GAP BED MODELS

LATHE SIZE	Dimensions - in Inches									
	A	C	D	F	G	H	J	K	L	S
15"	43-1/4	22	53-1/2	9-3/8	18-3/4	43	3-3/4	17-3/8	16	10-3/4
18"	46-1/2	24	54-1/2	10-5/8	21-1/4	42-1/2	3-3/4	17-3/8	18-1/2	13-1/4

15" Lathe						
Actual turning distance	36	48	66	78	90	108
Center Distance (N) (With L-0 Nose Only)	46	58	76	88	100	118
M	102	114	132	144	156	174
O (approx.)	64-3/4	76-3/4	45	51	57	66
P (approx.)			50	56	62	71

18" Lathe						
Actual turning distance	36	48	66	78	90	108
Center Distance (N) (With L-1 Nose Only)	43-11/16	55-11/16	73-11/16	85-11/16	97-11/16	115-11/16
M	102	114	132	144	156	172
O (approx.)	64-3/4	76-3/4	45	51	57	66
P (approx.)			50	56	62	71

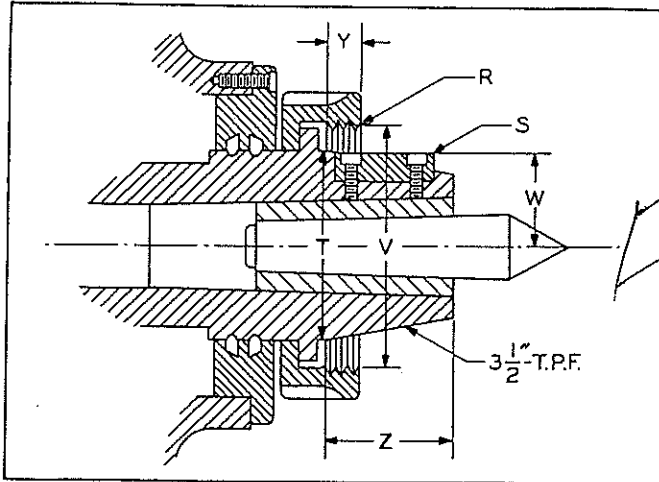

Figure 3-3.

SPINDLE NOSE DIMENSIONS STANDARD AND FIXED GAP BED			
SIZE OF LATHE	10"	12-1/2" & 15"	18"
SIZE AND TYPE NOSE	L-00	L-0	L-1
R	6 NS-RH	6 NS-RH	6 NS-RH
S	3/8	3/8	5/8
T	2-3/4	3-1/4	4-1/8
V	3-3/4	4-1/2	6
W	1.370 1.363	1.620 1.613	2.0575 2.0505
Y	9/16	5/8	3/4
Z	1-7/8	2-1/4	2-3/4

3-5. FOUNDATION.

3-6. A special foundation is not essential for this machine. However, it is advisable to place it on a substantial foundation of concrete if possible. If placed on a wooden floor, care should be taken to see that it is adequately supported and free from

vibration. If the machine is to be placed on an upper floor, locate it directly over a supporting beam or girder to reduce any vibration generated by nearby machines.

3-7. UNCRATING THE MACHINE.

3-8. Upon receipt of shipment, remove crating carefully, but do not remove skids from under the legs until the lathe has been moved to the approximate place selected for its erection.

3-9. CLEANING THE MACHINE.

3-10. Do not move the carriage or tailstock on the bed ways before cleaning thoroughly and oiling the ways. Use a good clean grease solvent to remove slushing compound and dirt accumulated in transit. Use rags rather than waste to eliminate lint. Do not use an air hose as this will force grit and dirt into important functioning units. Use a stiff bristle brush to get into corners and to clean leadscrew thoroughly. When the machine has been cleaned satisfactorily, rub clean machine oil over all ways and make certain no grit remains. Before moving the carriage on the bed, remove the filler plug on the top of the carriage and fill the apron with the proper oil as specified in the Lubrication Chart. Pump the one shot oil plunger several times to force oil to carriage ways on bed. Then proceed with moving the carriage to balance the load. Also check the end gearing for proper meshing of gears. Clearance between meshing gear teeth should be .003 in. to .004 in., the thickness of a piece of paper.

3-11. LIFTING THE MACHINE.

3-12. To obtain a balanced condition before lifting, it is necessary to move the tailstock to the right-hand end of the bed and clamp it there (see paragraph 3-10), and be sure to clean bed ways before moving carriage or tailstock. With the cross support "A" under the approximate center of gravity, lift the machine about 1 in. from the floor and make minor adjustments of the center of gravity by moving the carriage along the bed.

NOTE

Make certain the load is on balance and that the sling does not touch the lead-screw or control rod before lifting.

3-13. If a crane is used in lifting, exercise care that none of the mechanism is damaged. Chain, wire cable, or rope may be used to lift the lathe. If ropes are used, be certain that they are strong enough to safely carry the weight of the machine. The finished surfaces of the machine must be protected from chains by using wooden blocks. Figure 3-4 shows the machine after crating has been removed. The method of lifting is shown by figure 3-5. After removing cross support "A", place it under the bed as shown, making certain it does not contact control rod. This support has been offset to avoid this condition, so be certain it is properly set before lifting.

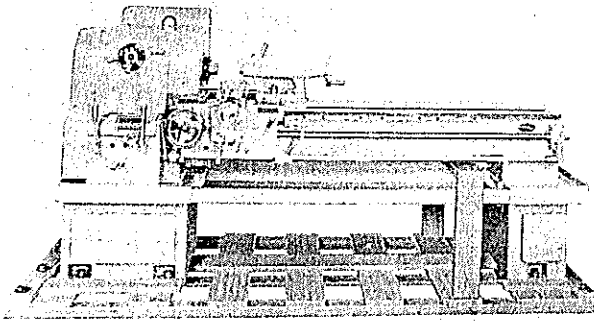

Figure 3-4. Lathe with Crating Removed

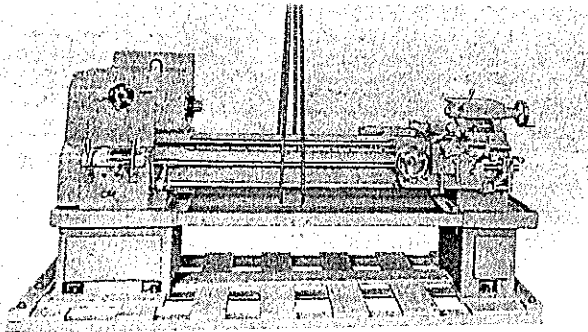

Figure 3-5. Method of Lifting

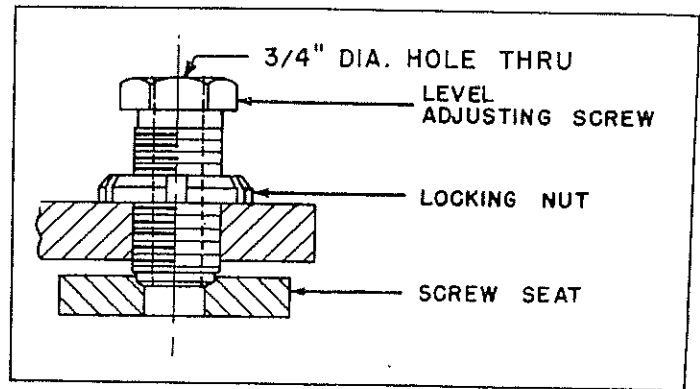

Figure 3-6. Leveling Jack Assembly

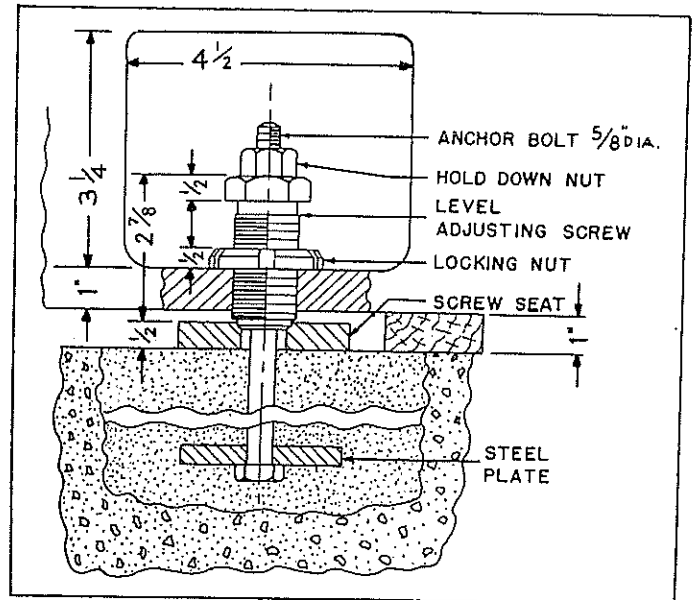

Figure 3-7. Anchoring Machine

3-20. ANCHORING TO CONCRETE FLOOR

3-21. If the lathe is to be bolted to a concrete floor, anchor bolts (not supplied with the lathe) should be used. If the lathe is to be fastened down on a wooden floor, lag screws may be used. Since the center distance between bolt holes as shown on the dimensional drawing are approximate, it will be necessary accurately to locate the anchor bolts or lag screws in the floor.

3-22. This can be done by setting the machine in its exact location and marking the leveling screw locations directly on the floor. Then, in the case of a concrete floor, proceed as follows:

3-23. Move the machine out of the way and drill the holes for the anchor bolts about 6 in. in diameter and 6 in. deep.

3-24. Raise the machine with a crane approximately 10 in. from the floor. Place 4 in. square steel plates and screw seats on 5/8 in. diameter anchor bolts, 9-1/2 in. long, and insert the bolts through the bores in the level adjusting screws, engaging the holddown nuts on the bolts to hold the entire assembly in place. Lower the machine into position, placing a 1 in. thick board under each leg of the lathe.

3-14. LEVELING THE MACHINE.

3-15. Leveling a lathe and keeping it level is one of the primary essentials in proper lathe operation.

3-16. Cincinnati Tray-Top lathes are equipped with built-in leveling jacks to simplify this operation. Four are located in the headstock leg, two in the tailstock leg, and two in each center leg (if supplied).

3-17. The complete leveling jack consists of the parts shown in figure 3-6.

3-18. If the machine is not to be fastened to the floor, it is only necessary to see that the screw seats are properly placed before proceeding with the leveling as described below.

3-19. It may be desirable to anchor the machine firmly in place by bolting it to the foundation. This can be accomplished by means of the hole through the center of the leveling jack.

3-25. Fill the holes around the anchor bolts with quick drying cement, thin enough to flow easily.

3-26. After the cement around the anchor bolts has set, the boards should be removed, the machine lowered to the floor, and the holddown nuts threaded onto the anchor bolts. The leveling jack assembly appears as in figure 3-7. The machine is now ready for leveling.

3-27. ANCHORING TO WOOD FLOOR

3-28. Where the machine is to be fastened to a wooden floor by lag screws, the pilot holes for the lag screws can be drilled after their locations have been determined as indicated in paragraph 3-21 above. Then when the machine is spotted over the screw holes in the floor and the lag screws have been partially screwed down, the leveling operation can proceed.

3-29. PROCEDURE FOR LEVELING.

3-30. Use a precision level that is graduated to at least .001 in. per foot. A carpenter's level or the level in a machinist's combination square is not accurate enough.

3-31. The leveling process is accomplished in two phases, the first being the preliminary leveling and the second the final leveling. The preliminary leveling is to remove any pronounced twist in the bed and should be done with the units remaining in one position. This is accomplished in the following manner.

3-32. Place the level across the top of the vee ways close to the headstock as shown in figure 3-8.

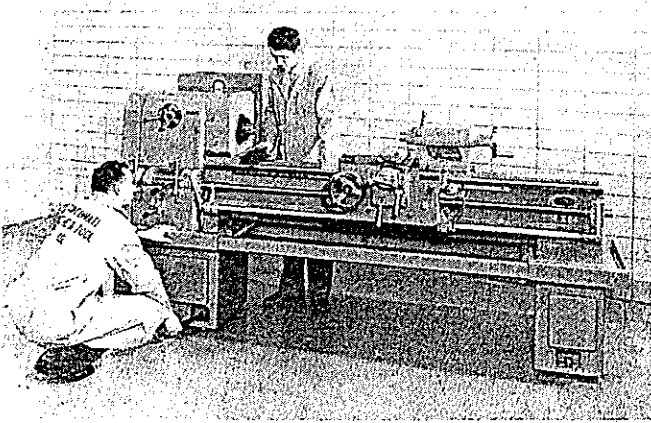

Figure 3-8. Leveling the Lathe

3-33. Adjust the screws under the headstock end leg until reading is zero. Then move the level to the tailstock end and with the level across top of the vee ways adjust the screws under tailstock end leg until reading is zero. Then recheck and make minor adjustments with the level at each of the above mentioned positions. This completes the preliminary leveling.

3-34. For final leveling, place the level lengthways on the front flat way close to the headstock end and

adjust screws under headstock end leg until reading is zero and at the same time checking with the level across the top of the bed ways to make certain these adjustments do not cause a twist in the bed.

3-35. Place the level lengthways on the front flat way, close the tailstock, and repeat the operations above, also checking with the level across the vee ways to eliminate any twist.

NOTE

Repeat these operations and make whatever minor adjustments are required.

3-36. The next operation is to level the lathe crossways by placing the level across the carriage wings and moving the carriage from one end of the bed to the other without disturbing the position of the level. If the level shows any variation throughout its travel, the screws nearest the point where variation occurs should be raised or lowered to bring the level back to zero.

3-37. Any adjustment made to bring the lathe level in one direction may affect the level of the lathe in the other direction, and it is only a combination of adjustments that will bring the lathe into proper level.

3-38. During the first week of operation, or until foundation has "set," the level of the machine should be checked frequently. Periodic rechecks should be made at least every six months.

3-39. LUBRICATION.

3-40. The importance of correct lubrication cannot be stressed too strongly. Thorough lubrication of the machine must be done after the lathe has been unpacked and before it is used. See Section IV for detailed instructions and for the required specification of the lubricants.

3-41. ELECTRICAL CONTROLS (See also wiring diagrams Pages 23 and 24.

3-42. ALL-ELECTRIC DRIVE (Standard).

3-43. Complete electrical equipment consisting of magnetic reversing starters, reversing drum switch, non-fused disconnect switch, and instant reversing main drive motor, is furnished.

3-44. CLUTCH DRIVE.

3-45. Complete electrical equipment consisting of start-stop-reverse push buttons mounted on the headstock, magnetic reversing starters, non-fused disconnect switch, and instant reversing main drive motor, is furnished.

3-46. ALL-ELECTRIC (Standard) AND CLUTCH DRIVE.

3-47. For all AC circuits of 220 volts and over, a control transformer with 110 volt coils is supplied. All electrical equipment (except pushbuttons) is lo-

cated on a panel in the compartment at the rear of the headstock.

3-48. Access to the electrical panel may be gained only after throwing the disconnect switch on the compartment door to the "OFF" or "OPEN" position, removing the Allen screws, and opening the door.

3-49. An independent selector switch for the coolant pump (when supplied), is mounted on the front of the headstock, and a magnetic starter for the pump is included on the electrical panel.

3-50. OPERATING A CINCINNATI TRAY-TOP LATHE.

3-51. Study the functional diagrams (Figs. 3-9, and 3-10) and become familiar with the operating units and control levers.

3-52. All Cincinnati Tray-Top lathes are equipped with a preloaded friction type safety clutch (see paragraph 5-27 and figure 5-5) to prevent possible dam-

age by overloading to elements of the feed transmission.

3-53. If the safety clutch slips in operation, it will be necessary to let it cool before again operating the machine. This is necessary in order to bring the safety clutch back to its full load-bearing capacity.

3-54. ALL-ELECTRIC DRIVE (Standard).

3-55. Check the rotation of the motor. To do this, turn the disconnect switch to the "ON" position. Momentarily engage the spindle start and stop lever in its upper position to jog the spindle. As you face the spindle from the tailstock end, the spindle should rotate in a counterclockwise direction. If it does not, it is necessary to reverse the rotation of the motor before attempting to operate the lathe.

3-56. The lathe is started and stopped with manually operated levers on the control rod which starts and stops the main drive motor through the medium of an electric drum switch and magnetic starters.

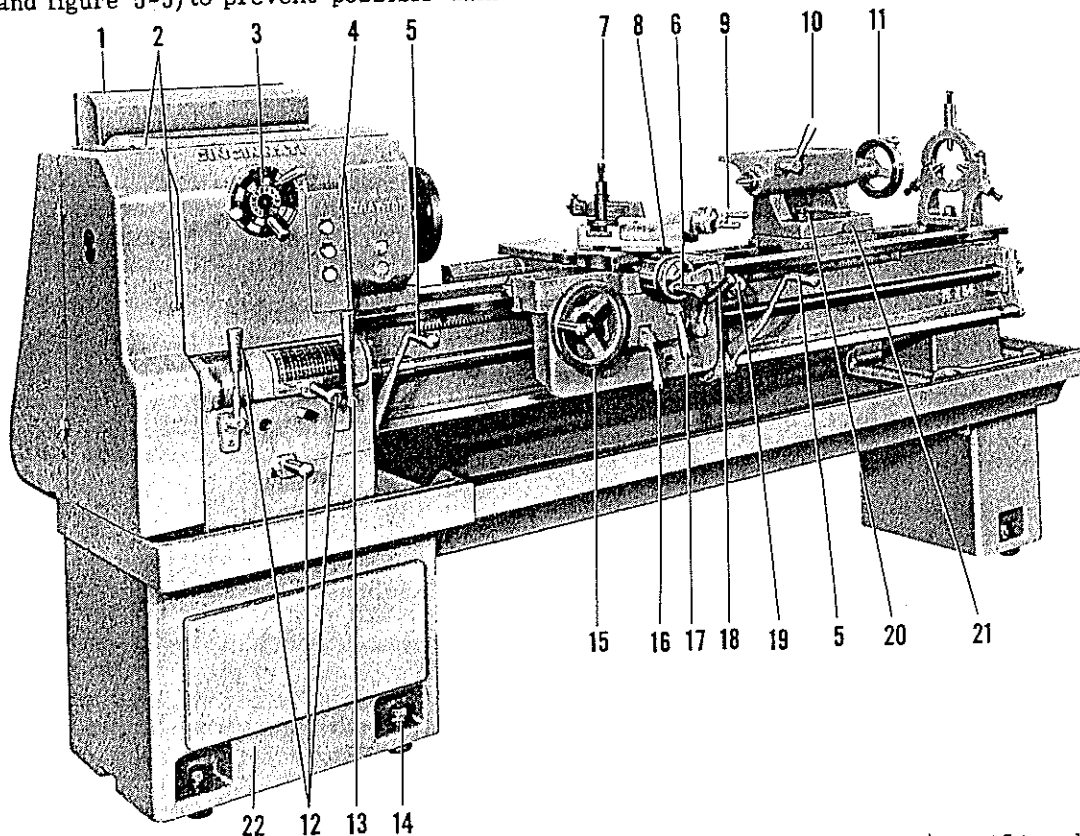

Figure 3-9. Functional Diagram, Cincinnati Tray-Top Lathe, 10", 12-1/2", 15" and 18", Engine and Toolroom Models

- | | | |
|--|--|---|
| 1. Electrical Compartment | 9. Compound Rest Adjusting Handle | 17. Cross Slide Power Feed Engaging Lever |
| 2. Guard Latches | 10. Tailstock Spindle Clamp | 18. Half-Nut Engaging Lever |
| 3. Spindle Speed Selector Dial | 11. Tailstock Spindle Handwheel | 19. Chasing Dial |
| 4. Push Button Panel | 12. Thread and Feed Selector Levers | 20. Tailstock Clamping Nut |
| 5. Headstock Spindle Start-Stop Levers | 13. Leadscrew Reverse | 21. Tailstock Set-Over Adjusting Screw |
| 6. Cross Slide Adjusting Handle | 14. Leveling Screw | 22. Storage Compartment |
| 7. Tool Post | 15. Carriage Handwheel | |
| 8. Carriage Clamp | 16. Longitudinal Power Feed Engaging Lever | |

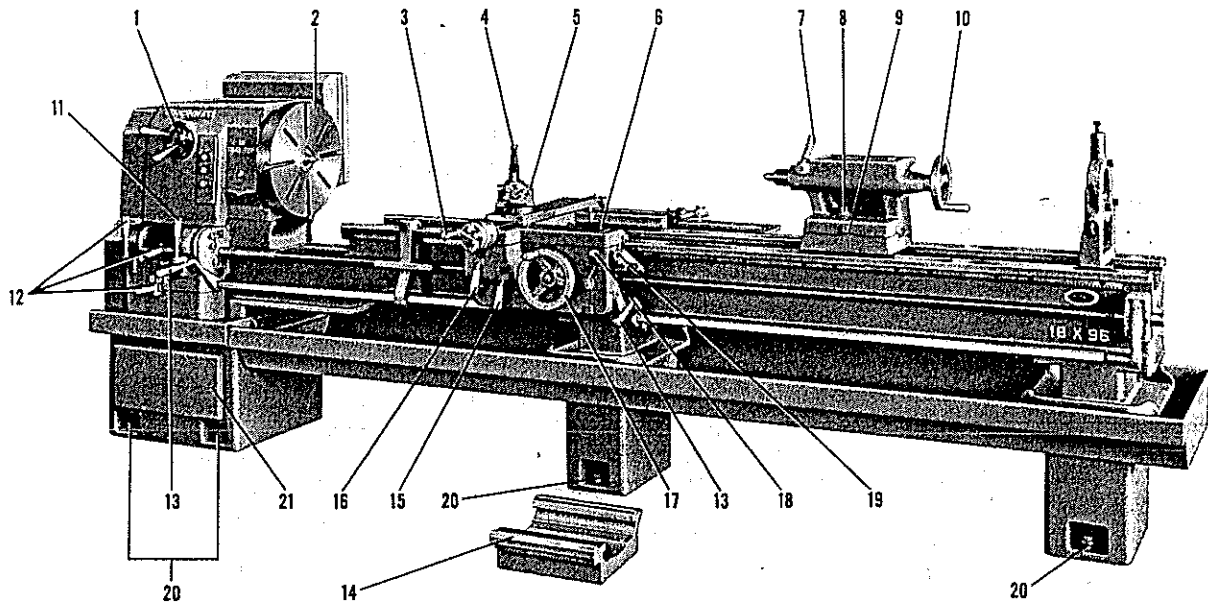

Figure 3-10. Functional Diagram, Cincinnati Tray-Top Lathe, 15" and 18" Fixed Gap Bed Models

- | | |
|-----------------------------------|--|
| 1. Spindle Speed Selector Dial | 12. Thread and Feed Selector Levers |
| 2. Gap Face Plate | 13. Spindle Start-Stop Lever |
| 3. Cross Slide Adjusting Handle | 14. Removable Gap Block |
| 4. Tool Post | 15. Longitudinal Power Feed Engaging Lever |
| 5. Compound Rest Adjusting Handle | 16. Cross Slide Power Feed Engaging Lever |
| 6. Carriage Clamp | 17. Carriage Hand Wheel |
| 7. Tailstock Spindle Clamp | 18. Half-Nut Engaging Lever |
| 8. Tailstock Clamping Nut | 19. Chasing Dial |
| 9. Tailstock Set-over Screw | 20. Leveling Screw |
| 10. Tailstock Hand Wheel | 21. Storage Compartment |
| 11. Leadscrew Reverse | |

3-57. To obtain forward rotation of the spindle, pull the start-stop lever up. To reverse the spindle, push the start-stop lever down. For quick spindle stopping, move the start-stop lever past the neutral position momentarily, which tends to reverse the motor. Return the lever to the neutral position quickly to prevent reverse rotation of the spindle.

3-58. CLUTCH DRIVE.

3-59. Check the rotation of the motor. To do this, turn the disconnect switch to the "ON" position and press the "FORWARD" button on the electrical panel to start the motor. Engage the clutch by raising the start-stop lever. As you face the spindle from the tailstock end, the spindle should rotate in a counter-clockwise direction. If it does not, it is necessary to reverse the rotation of the motor before attempting to operate the lathe.

3-60. Forward spindle rotation is obtained as in paragraph 3-59 above. To reverse rotation of the spin-

dle lower the spindle start-stop lever to neutral, press the "REVERSE" push-button, and re-engage the clutch by raising the spindle start-stop lever. To stop the spindle depress the spindle start-stop lever which then engages a multiple-disc friction type brake.

3-61. The rapidity of engagement of the drive clutch, and application of the brake, should be gaged with reference to the weight of the workpiece and the holding device.

3-62. If these are heavy, engage the clutch gradually until the spindle picks up speed. Apply the brake gradually at first, and then with increasing pressure as the spindle slows down.

3-63. SPINDLE SPEED SELECTION.

3-64. Spindle speeds are changed by three levers, the positions of which are selected by reference to a direct reading "color-match" dial located on the

front face of the headstock. Four groups of colors are employed to distinguish the various speed selectors. The complete dial consists of a fixed reference ring, outer and intermediate adjustable selector rings, and an inner dial showing the various speeds.

3-65. To obtain a specific spindle speed, for example, one of the three speeds located in the green sector, proceed in the following manner:

a. Stop headstock spindle. **DO NOT ATTEMPT TO MAKE SPEED CHANGES WITH THE SPINDLE RUNNING.** Rotate the spindle by hand if proper engagement of sliding gears is not obtainable when changing speeds.

b. Move outer adjustable selector ring (upper left-hand lever) so the green mark coincides with the green mark of the fixed reference ring.

c. Move intermediate adjustable selector ring (upper right-hand lever) so that green mark coincides with the green mark on the outer ring.

d. Move the inner dial (lower lever) so that the desired speed in the green sector coincides with the green mark on the intermediate dial.

3-66. Follow the same procedure for speeds located in the blue, yellow or red sectors, matching the corresponding colors.

3-67. A neutral position of the headstock gearing is readily obtainable at any time by moving the outer adjustable selector ring (upper left-hand lever) so "N" coincides with the indicator at the top of the fixed reference ring.

3-68. THREAD AND FEED SELECTION.

3-69. The quick change box provides selection of 48 thread and feed changes through positioning the index slide, one two-position lever, and one-three-position lever. To obtain the desired thread or feed, proceed in the following manner:

a. **STOP THE HEADSTOCK SPINDLE.** To facilitate spur gear engagement, jog the spindle when necessary.

b. Pull out the index slide plunger and permit the slide to drop, thereby disengaging the tumbler gears.

c. Shift the two-position lever to A or B, and the three-position lever to C, D or E as required for the selected thread or feed.

d. Move the index slide to any one of the eight positions, depending on the thread or feed desired, obtaining the approximate location by matching the appropriate line on the index plate with the fixed reference on the quick change box. Seat the index plunger in location hole for final setting of index plate.

3-70. Also incorporated in this unit is a leadscrew reverse lever to facilitate chasing right- or left-hand threads and to reverse the feeding direction of the carriage and cross slide.

3-71. To engage power movements to the carriage or cross slide, a drop lever engaging device, located on the apron, is employed.

3-72. CHASING THREADS.

3-73. CHASING ENGLISH THREADS ON MACHINES EQUIPPED WITH AN ENGLISH LEADSCREW.

3-74. The pair of half-nuts is engaged with the leadscrew by depressing the lever at the right side of the apron. This lever can be moved only with the feed engaging drop levers in the down or disengaged position. A simple interference device prevents the engagement of the drop levers, when the half-nut is closed or vice versa, to prevent damage to gearing.

3-75. The chasing dial to facilitate thread chasing is mounted on a swivel bracket on the right end of the apron. This dial is rotated by a small worm wheel which is engaged with the threads of the leadscrew and rotates as the leadscrew turns. The bracket can be swiveled to disengage the worm wheel from the leadscrew to reduce wear when not chasing threads. The procedure followed in chasing threads, when the tool setup has been completed, is to bring the carriage to the starting point of the thread by hand and then watch the graduations on the chasing dial as they pass the index mark on the bracket. When one particular graduation, say "zero," coincides with the index mark, the half-nuts are closed. The chasing dial remains stationary as it travels with the carriage until the half-nuts are opened again at the end of the thread. The tool is then withdrawn from contact with the work, the carriage returned by hand to the start of the thread, and the cross feed reset to the proper depth. The particular graduation on the chasing dial to be used for closing the half-nuts again depends on the lead of thread being chased.

3-76. The half-nuts can be closed at the point, without regard to the chasing dial, for any number of threads per inch divisible by four. The general rule to follow for all other threads, is, for even number of threads per inch, close the half-nuts on any line; for odd number of threads close the half-nuts on any numbered line; and for fractional threads close the half-nuts every full revolution. See instruction plate on carriage near chasing dial.

3-77. CHASING METRIC THREADS ON MACHINES EQUIPPED WITH AN ENGLISH LEADSCREW.

3-78. In less than fifteen minutes a Tray-Top Lathe with an English screw can be changed to cut a full series of Metric threads using the Quick Change Box in the normal manner.

3-79. Only two additional gears and another (Metric) thread index plate are required. (Supplied on special order.) One gear is pinned to the 120-tooth idler gear normally furnished so that only one gear need be stored when not in use.

3-80. Follow the directions given in Fig. 3-11 to make the conversion. Then refer to paragraph 3-81 below for Metric thread chasing instructions. Disregard and disengage the chasing dial after making the above conversion.

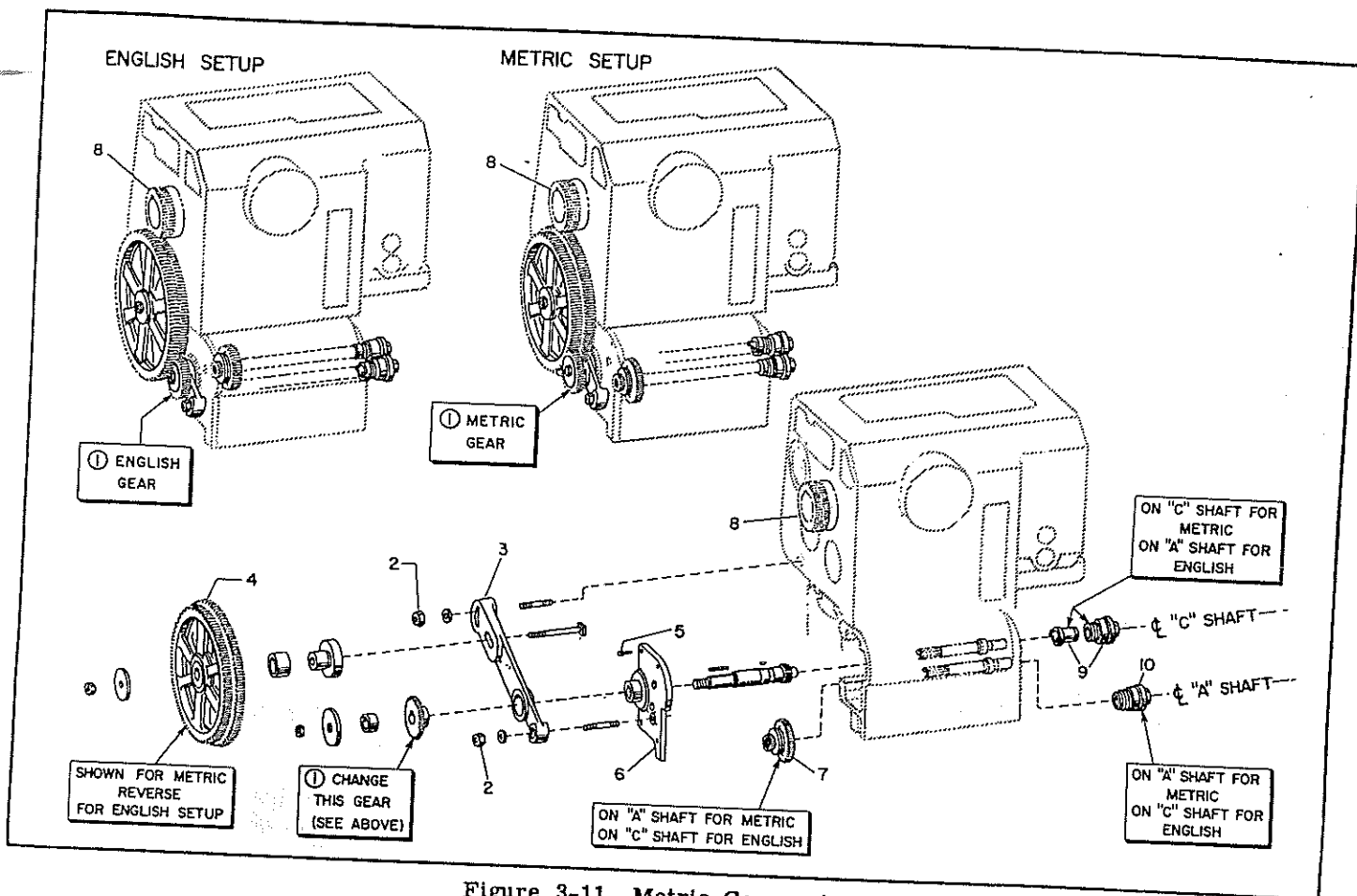

Figure 3-11. Metric Conversion

PROCEDURE

1. Remove end gearing cover.
2. Remove gear (1 - English).
3. Remove nuts (2) and pull off quadrant (3) with gear assembly (4) still attached.
4. Remove four socket head cap screws (5) and pull off end cover (6).
5. Remove gear (7) from top shaft (C) and place on bottom shaft (A) and replace cover (6).

6. Turn gear assembly (4) around so smaller gear is engaged with drive gear (8) and reassemble parts using gear (1 - Metric) in place of gear (1 - English).
7. Remove idler cap (10) from shaft (C).
8. Remove clutch and cap (9) from shaft (A) and place on shaft (C).
9. Place idler cap (10) on shaft (A).
10. Replace end gearing cover.
11. Replace English thread and feed plate on quick change box with Metric plate.

3-81. Move the carriage by hand to the starting point of the thread. Close the half-nuts and begin the chasing cut. At the end of the thread, withdraw the tool from contact with the work, but keep the half-nuts closed. Lower start-stop lever to neutral and press "REVERSE" pushbutton. Stay in reverse with half-nuts closed until carriage returns to the start of the thread. Reset the cross feed to the proper depth, and, with the half-nuts still closed, re-engage the tool with the work and take another cut.

3-82. Repeat the above operation until the full depth of thread is reached. Caution: the half-nuts must remain closed until the thread has been completely finish machined.

3-83. TAPER ATTACHMENT (TELESCOPIC).

3-84. The taper attachment is furnished as an extra and is supplied only when ordered. It incorporates the

use of a telescopic cross screw which does not have to be disengaged for turning taper work. This feature eliminates the necessity of disconnecting the cross screw nut, permits normal use of the cross feed adjustment, and greatly simplifies the transition from straight to taper turning.

3-85. Installation of this unit on machines in the field is not recommended. This is due to the necessity of installing a different cross screw than that normally supplied with a machine not originally equipped with a taper attachment. Therefore, it is advisable to order this attachment at the time the machine order is placed. In exceptional cases field installation is possible; however, additional service costs are involved.

3-86. The Swivel slide is graduated in both degrees (left end) and inches taper per foot (right end) and represents the included angle or taper.

3-87. To set the attachment for any desired taper, loosen clamping nuts "C", "D", "E", "F", and "G" (figure 3-12). The swivel bar can then be adjusted by hand to the approximate setting and after tightening nut "C", fine adjustments can be made by using the adjusting screw "B". Tighten clamping nuts "D", "F", and "G" when the proper setting has been obtained. Nut "E" must remain loose during taper turning. Move the tool into position for the first cut before tightening nut "A" which engages the taper attachment. To disengage the attachment loosen nut "A" and tighten nut "E" which must remain tight except during taper turning. If the taper attachment is not in regular or frequent service, the clamping block "H" should be removed to reduce wear on the bed.

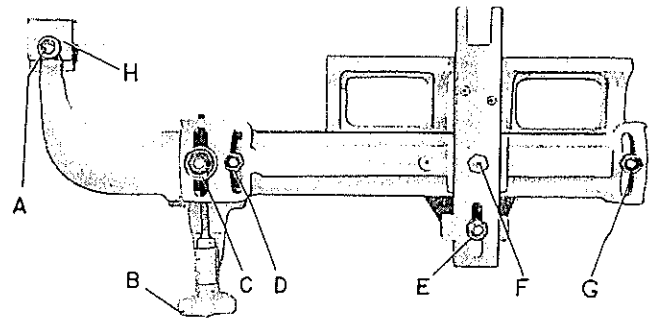

Figure 3-12. Taper Attachment

SECTION IV LUBRICATION

4-1. LUBRICATION.

4-2. The importance of correct lubrication cannot be over-emphasized. Under no circumstances should the lathe be operated without first seeing that it has been thoroughly oiled.

4-3. The successful and satisfactory operation of the lathe, as well as its useful service life, depend upon the care with which the lubrication instructions given below are followed.

4-4. Since all oil was drained from the machine before shipment, it is necessary at the outset to fill the reservoirs in the headstock, quick change box, and apron to the center of the sight gages with which each unit is provided. All of the other points indicated on the diagram and covered in the instructions should be thoroughly oiled.

NOTE

Lubricate electric motor according to motor manufacturer's recommendations. Do not over-lubricate.

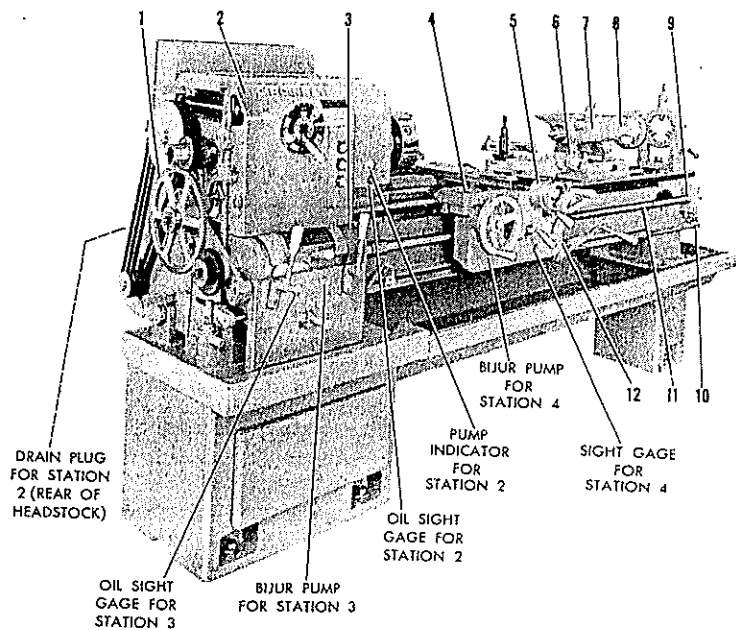

Figure 4-1. Lubrication Diagram

LUBRICATION DATA

STATION NUMBER	PART LUBRICATED	AMOUNT & TYPE LUBRICANT	FREQUENCY	INSTRUCTIONS
1	End gearing and bearings	* Medium quality fibrous grease	6 months	Open door in end gearing cover. Grease gearing.
2	Headstock gearing	** P-55 10" - 1-1/2 Gals. 12-1/2" - 2-1/4 Gals. 15" - 2-1/2 Gals. 18" - 3 Gals.	Keep filled	# Open door in end gearing cover to fill. Check oil sight gage daily. Watch pump indicator to see that oil is circulating. Drain and refill to center of gage every 6 months.
3	Quick change gear box	P-55 10" & 12-1/2" - 2/3 Qt. 15" & 18" - 1 Qt.	Keep filled	# Check oil sight gage daily. Operate Bijur pump at least daily. Drain and refill to center of gage every 6 months.

LUBRICATION DATA

STATION NUMBER	PART LUBRICATED	AMOUNT & TYPE LUBRICANT	FREQUENCY	INSTRUCTIONS
4	Apron gearing, lead-screw, bedways and cross slide	P-55 10" & 12-1/2" - 1/3 Qt. 15" & 18" - 3/4 Qt.	Keep filled	# Check oil sight gage daily. Operate Bijur pump twice daily. Drain and refill to center of gage every 6 months.
5	Cross screw	P-55	Daily	Use bench oil can.
6	Compound screw	P-55	Daily	Use bench oil can.
7	Tailstock spindle	P-55	Bi-Weekly	Use bench oil can.
8	Tailstock spindle nut	P-55	Bi-Weekly	Use bench oil can.
9	Leadscrew bearing	P-55	Bi-Weekly	Use bench oil can.
10	Control rod bearing	P-55	Bi-Weekly	Use bench oil can.
11	Leadscrew	P-55	Daily	Use bench oil can.
12	Control rod bearings on apron	P-55	Bi-Weekly	Use bench oil can.

* Medium fibrous grease equivalent to Valvoline X-5 and 1104; or Socony-Vacuum Gargoyle Viscolite No. 20, and Dorcia No. 150.

** P-55 is a good quality paraffinic base rust and oxidation inhibited general purpose oil, viscosity 200 to 220 seconds Saybolt at 100°F. Complete specifications on request. Approved sources and types include: Shell Oil Co., Tellus 29; Gulf Oil Co., Crest "B" and Harmony "B"; Texas Oil Co., Regal Oil "B" (R & O Type); Socony-Vacuum Oil Co., D.T.E. Medium; Sun Oil Co., Sunvis 921; Standard Oil Co., Esstic 45.

After draining, flush thoroughly with a mixture of four parts kerosene and one part light lubrication oil, and then refill at the end of the first two-month operating period. The second oil change should be made four months later and thereafter every six months to one year, depending on actual operating time of the lathe.

SECTION V

MAINTENANCE

5-1. GENERAL MAINTENANCE.

5-2. Be certain that the lathe is properly lubricated at all times and that oil reservoirs are filled to correct levels in accordance with lubricating instructions.

5-3. To insure prolonged accuracy of the machine, level the bed at installation, recheck in one month, again at two months, and at least every six months thereafter.

5-4. NEVER, UNDER ANY CIRCUMSTANCES, ATTEMPT TO SHIFT SPINDLE SPEEDS WITH THE SPINDLE RUNNING. Stop the machine and jog spindle, if necessary, to facilitate spur gear engagement.

5-5. ADJUSTMENTS.

5-6. Many adjustments and minor repairs, described below, can easily be accomplished when competently

supervised by your own maintenance department. The need of many of these adjustments will be greatly lessened if the instructions regarding the machine, particularly lubrication, are strictly adhered to.

5-7. ADJUSTING THE MAIN DRIVE VEE BELTS.

5-8. All Tray-Top Lathes are motor driven with the motor mounted on a hinged plate at the rear of the headstock end leg. This plate is equipped with two adjusting screws for securing proper vee belt tension. To tighten belts, loosen the lower screw sufficiently to permit the weight of the motor to provide the correct tension. Then tighten the upper screw until the motor plate is firm.

CAUTION

Too much tension created on the side of the bed by belt tension adjusting screws will throw headstock out of alignment.

5-9. ADJUSTING THE CROSS SLIDE AND COMPOUND REST GIBS.

5-10. Headless type taper gibs are provided to compensate for wear between the bearing surfaces of these sliding units. Two adjusting screws are employed for each gib, one located at the thick or front end of the gib and the other at the thin or rear end. To adjust this type of gib, proceed in the following manner:

- a. See that power engaging lever of the unit containing the gib to be adjusted is in the neutral position.
- b. Loosen the adjusting screw at the rear of the gib several turns.
- c. Turn the front adjusting screw until tight, then back off one turn.
- d. Retighten the rear adjusting screw.

NOTE

Gibs should never be drawn up so tightly as to prohibit free movement of the particular unit with operating handle. Tight adjustments squeeze out the oil film, resulting in rapid wear.

5-11. ADJUSTING THE HEADSTOCK SPINDLE BEARINGS (See Figure 5-1).

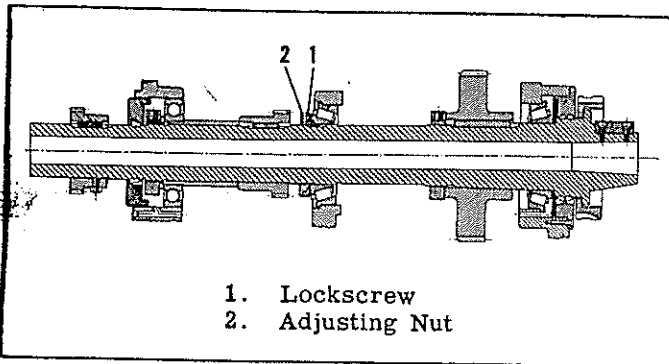

Figure 5-1. Adjusting Headstock Spindle Bearings

- a. Run the headstock about an hour, until the bearings are warm.
- b. Remove the top cover of the headstock unit.
- c. Move upper left-hand lever on spindle speed selector dial so "N" on outer adjustable selector ring coincides with small pointer on fixed reference ring.
- d. Rotate the spindle by hand until lock screw (1) is in upper position so it may be loosened.
- e. Tap lightly on adjusting nut next to lock screw to break loose the shoe under the lock screw.
- f. Tighten nut (2) with a spanner wrench until bearings are drawn up snug.

CAUTION

Spindle must rotate freely but be free of shake.

- g. Lock set screw.
- h. Replace the cover.

5-12. ADJUSTING THE CLUTCH AND BRAKE MECHANISM (See Figure 5-2).

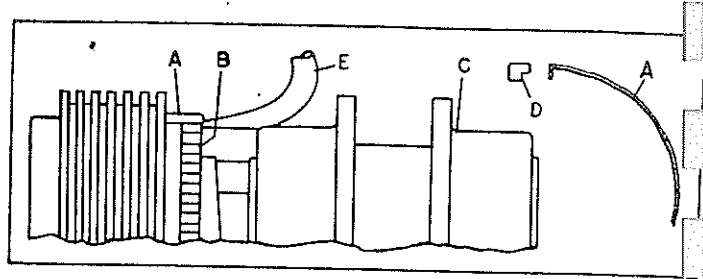

Figure 5-2. Clutch Adjustment

5-13. The multiple disc clutch in the headstock has been carefully adjusted before leaving the factory and is of adequate size. However, it is subject to wear and may require adjustment from time to time. The clutch, which is located on the drive shaft near the top of the headstock and drive pulley, can be adjusted without difficulty by removing the head cover plate and following the directions in the next paragraph.

NOTE

Tool E as shown in figure 5-2 is a bent scratch awl.

5-14. To adjust the clutch, before operation, first see that the shifter sleeve "C" is in neutral. Next lift spring "A" with tool "E" resting on the sleeve, as shown. Do not use a screw driver. Lift spring just high enough for lip "D" to clear the teeth on collar "B". Then turn collar "B" one notch at a time, clockwise, BY HAND.

CAUTION

Lifting the spring too high may cause breakage, or the spring to fly off.

5-15. ADJUSTING THE LEADSCREW THRUST (See Figure 5-11).

5-16. The adjustment for the lead screw thrust is located at the extreme right end of the lead screw. Adjustments should be made with the outer nut (10) only after the set screw and shoe (9) have been loosened. Tighten the nut sufficiently to eliminate excessive end play in the lead screw, but do not overload the thrust bearings. Lock the nut in the adjusted position by retightening the set screw.

5-17. ADJUSTING THE CROSS FEED THRUST.

5-18. When backlash occurs in the cross feed adjusting screw, the small nut at the end of the screw, between the dial and the ball crank, should be tightened in the same manner as that described in the preceding paragraph.

5-19. ADJUSTING THE COMPOUND REST END THRUST (See Figure 5-3).

5-20. Adjustment for end play in the compound rest is made in the following manner:

- a. Knock out the taper pin (1) and remove the ball crank handle.
- b. Slide the bushing (2) and dial (3) off the shaft.
- c. Remove locking set screw (4).
- d. Tighten set screw (5) only enough to take out excessive end play.

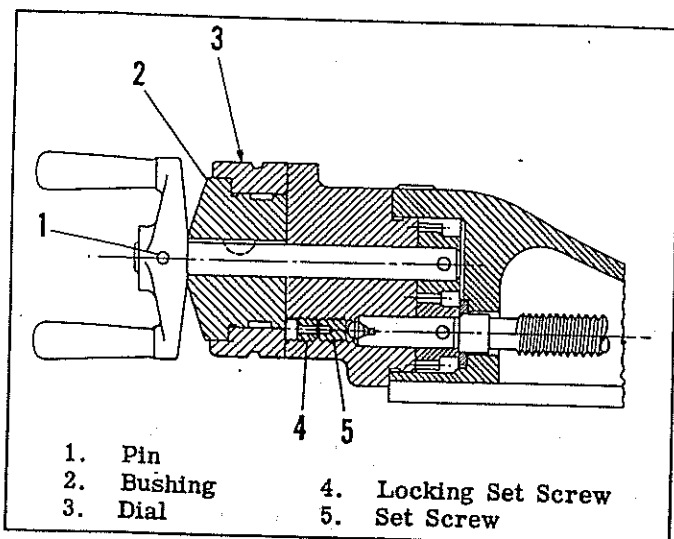

Figure 5-3. Adjusting Compound Rest End Thrust

e. Replace the locking set screw and other parts in the reverse order in which they were removed.

5-21. If the lathe is equipped with a taper attachment it will be necessary to eliminate any remaining excessive end play by adjusting the nut and thrust bearings at the taper attachment end of the cross feed screw as explained in paragraph 5-16.

5-22. ADJUSTING THE HALF-NUT ENGAGEMENT.

5-23. Under normal operating conditions, it is doubtful if this adjustment will ever be required. However, if excessive use of this unit necessitates an adjustment, stop the machine and proceed in the following manner:

- a. Back out the adjusting screws, located in the arm of the lower half-nut; several turns.
- b. Move half-nut engaging lever to down position.
- c. Tighten adjusting screws until they contact the upper half-nut.
- d. Raise engaging lever and advance adjusting screws one-quarter to one-half turn to provide proper clearance between half-nuts and leadscrew. This clearance is essential to prevent a binding action between these units.

5-24. ADJUSTING POWER FEED ENGAGING DROP LEVER (See Figure 5-4).

5-25. If the power feed engaging drop levers do not remain in the engaged position, the following adjustment is required:

- a. Remove the drop lever housing (1) by removing the three Allen screws holding this cover in position.
- b. Loosen the Allen set screw (2) in the outer spanner nut (3) on the feed shaft.
- c. Adjust the spanner nut so that the desired tension in the engagement of the drop lever exists. Make only a slight adjustment and check by engaging the drop lever. If the spanner nut is over-tightened, excessive wear will result on the feed shaft bearings.
- d. Lock the spanner nut in position by retightening the Allen set screw.
- e. Replace drop lever housing.

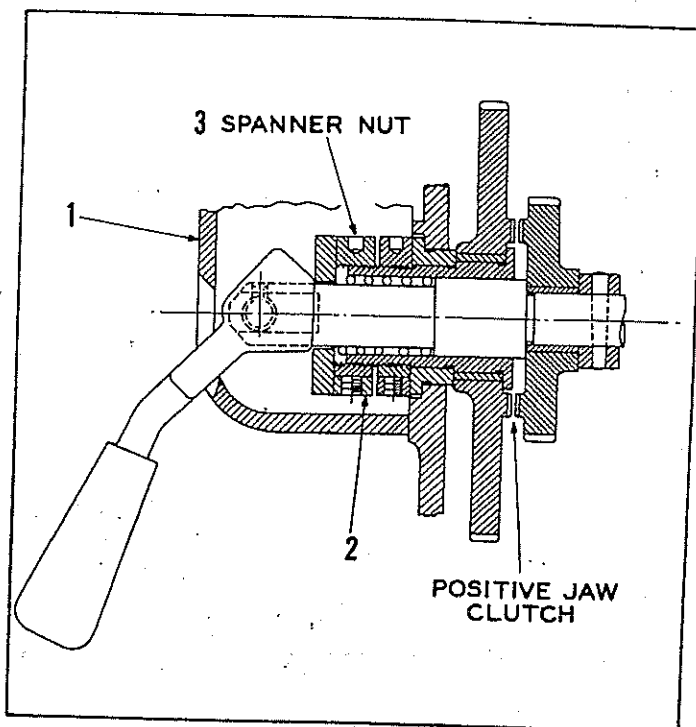

Figure 5-4. Power Feed Engaging Drop Lever

5-26. SAFETY CLUTCH (See Figure 5-5).

5-27. To prevent possible damage to elements of the feed transmission, including the quick change box, a spring loaded friction type safety clutch is used to

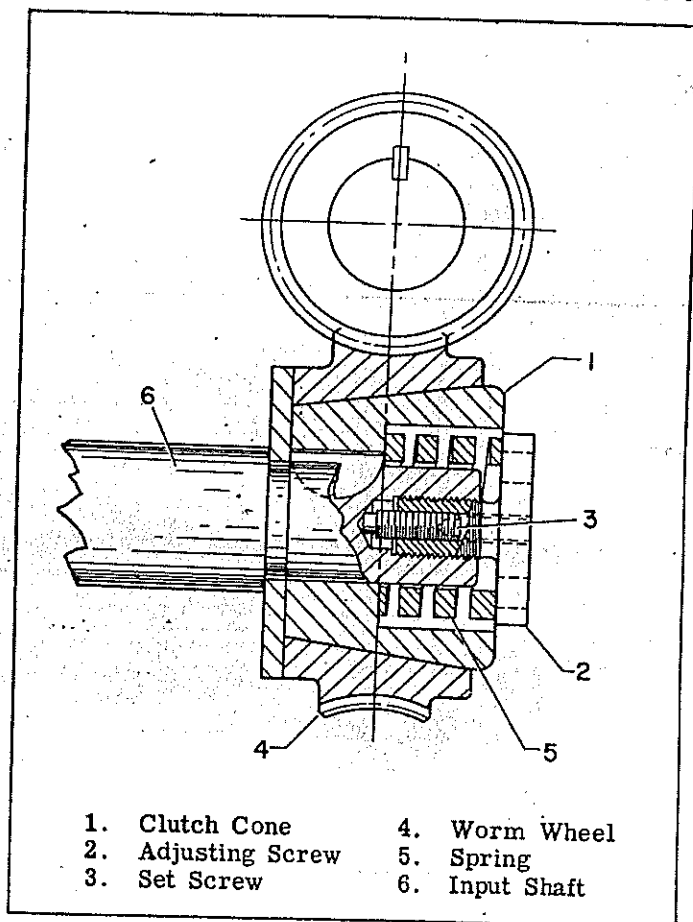

Figure 5-5. Safety Clutch

transmit power from the worm wheel at the rear of the apron to the input shaft in the apron.

- a. The safety clutch has been carefully set at the factory to slip whenever the feed transmission is subjected to overloading of any kind.
- b. To re-set or adjust the safety clutch it is necessary to remove the apron from the machine as described in paragraphs 5-37a thru c, "To Remove Apron Unit".
- c. Loosen set screw (3) in safety clutch and tighten adjusting screw (2) by turning it in a clockwise direction.
- d. Tighten set screw. Torque wrench reading when clutch slippage takes place should not exceed 250 inch-lbs for 15" & 18" and 125 inch-lbs for 10" & 12-1/2".
- e. When desired reading is attained, tighten set screw and re-assemble apron on lathe.

NOTE

When the clutch slips in operation, let it cool before again operating the machine. This is necessary in order to bring the clutch back to its full load-bearing capacity.

5-28. TO REMOVE AND DISMANTLE SPEED SHIFTER MECHANISM.

- a. Remove tray cover from headstock.
- b. Set spindle speed selector levers in lowest speed position.
- c. Unscrew the four screws holding the two rack spacers in place, and lift out.
- d. Drive out the taper pin in the drive shaft shifter yoke.
- e. Loosen set screw, tap to free lock shoe, and unscrew lock nut from drive shaft shifter rod at rear of headstock.
- f. Withdraw the drive shaft shifter rod from the front of the headstock, and remove shifter linkage and yokes as a unit.
- g. Complete by removing the two shifter dials from the front of the headstock.

5-29. TO REMOVE AND DISMANTLE HEADSTOCK SPINDLE (See Figure 5-6).

- a. Proceed as described in paragraph 5-28a thru f, "To Remove and Dismantle Speed Shifter Mechanism".
- b. Remove face plate or chuck, center, and center bush. Remove tray cover from top of headstock. Remove end gearing guard.
- c. Remove end gearing and quadrant.
- d. Remove bearing cap (2). This cap is a plug fit in the housing and has two 3/8-16 tapped holes to facilitate removal. Two studs at least 6 in. long and having at least 2 in. of threads at the outer end are fitted into the tapped holes. A bar is then placed over the studs and rests against the end of the spindle (1). Two nuts are then screwed onto the studs and bear against this bar. By alternately tightening each nut, the cap can be removed from the housing.
- e. To remove rear lock nut (3), loosen set screw, using an Allen wrench, and tap to free lock shoe. Then unscrew nut from spindle.
- f. Remove washer (4). To remove ball bearing and spacer (5) tap helical gear (6) toward the rear of the spindle with a brass bar. Slide gear off key. Remove key.
- g. Loosen set screw in adjusting nut (7) for rear tapered roller bearing (8). Back nut off threads. Remove key (9).
- h. Loosen set screw in adjusting nut (10) for large face gear (11). Tap gear to loosen from taper and slide it back. Back nut off threads and remove key.
- i. Remove four Allen cap screws (12) from spindle front bearing cap.
- j. Tap spindle forward, removing in turn bearing with spacer (5), helical gear (6), rear tapered roller bearing adjusting nut (7), bearing (8), large face gear adjusting nut (10) and large face gear (11).
- k. To remove the front Timken bearing cone (13), oil slinger (14), spindle front bearing cap (15), and spindle nut (16) from spindle, tap the spindle nut toward the rear of spindle with a brass bar or babbit hammer until these parts are free.

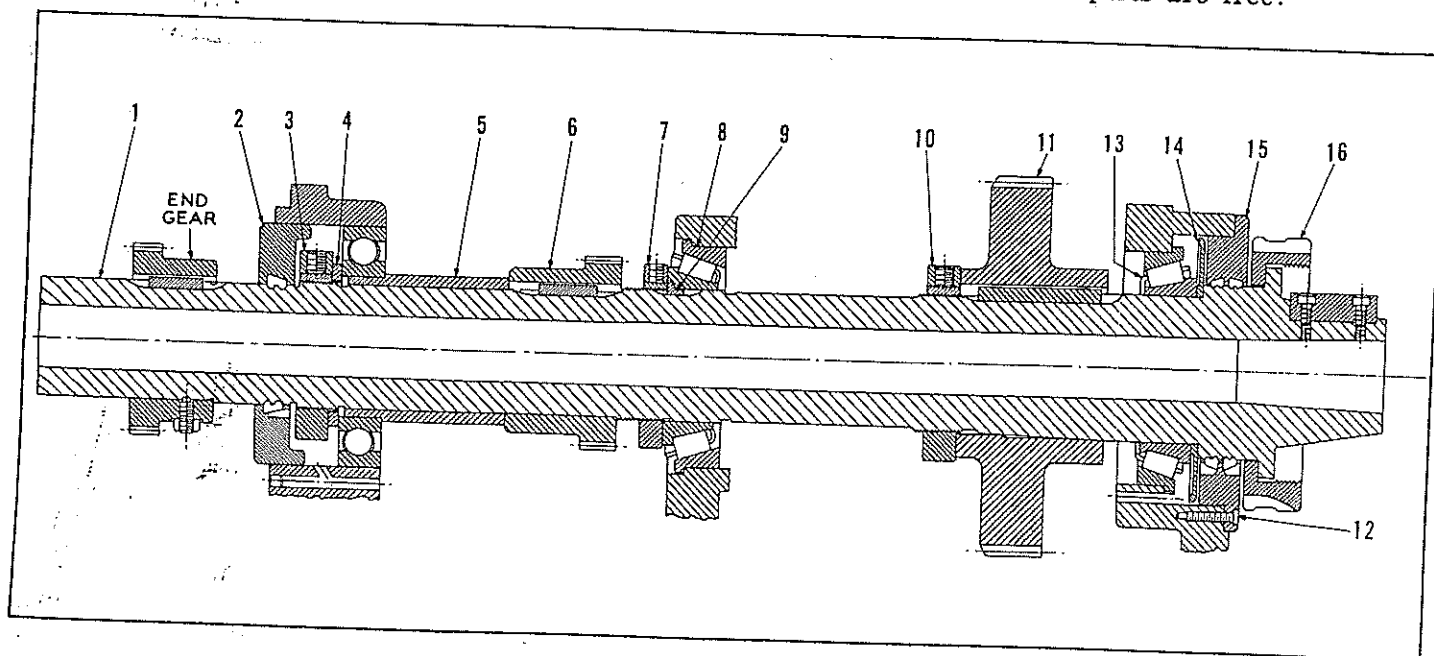

Figure 5-6. Headstock Spindle

5-30. TO REMOVE DRIVE SHAFT.

5-31. STANDARD DRIVE (See Figure 5-7).

- a. Proceed as described under paragraphs 5-28a thru f, "To Remove and Dismantle Speed Shifter Mechanism".
- b. Remove end gearing guard, end gearing, quadrant and pulley belts.
- c. Loosen set screw in lock nut (2) holding pulley, tap to free lock shoe, and unscrew nut from drive shaft. Remove drive shaft pulley and key.
- d. Loosen set screw in second lock nut (11) for adjusting bearing, tap to free lock shoe, and unscrew nut from drive shaft.
- e. Unscrew the socket head screws (12) from the bearing retainer bushing (4).
- f. Remove plug (6) in headstock at right end of drive shaft. This can be done by screwing a rod, with a nut on its outer end, into the plug. Slide a clearance drilled weight along the rod and hammer against the nut until the plug is withdrawn.

- g. Loosen set screw in nut (5) on right end of drive shaft, tap to loosen shoe, remove nut, and use a brass bar to tap drive shaft (3) out thru pulley end, removing in turn the bearing retainer bushing (4), left end bearings (8), gear (10), center bearing (1) and cluster gear (9). Right end bearing (7) will then lift out.
- h. Reverse this procedure to re-assemble.

5-32. CLUTCH DRIVE (See Figure 5-8).

- a. Proceed as described in paragraphs 5-31a thru g, "Standard Drive"; however, prior to tapping out the drive shaft, line up the teeth of the oil pump gear with any of the three openings in the clutch housing.
- b. To remove clutch (10) from drive shaft, remove bearing, and drive out pin holding clutch on shaft (3). Push clutch toward right end of shaft, remove split ring, and slide complete clutch off shaft.
- c. Reverse this procedure to re-assemble.

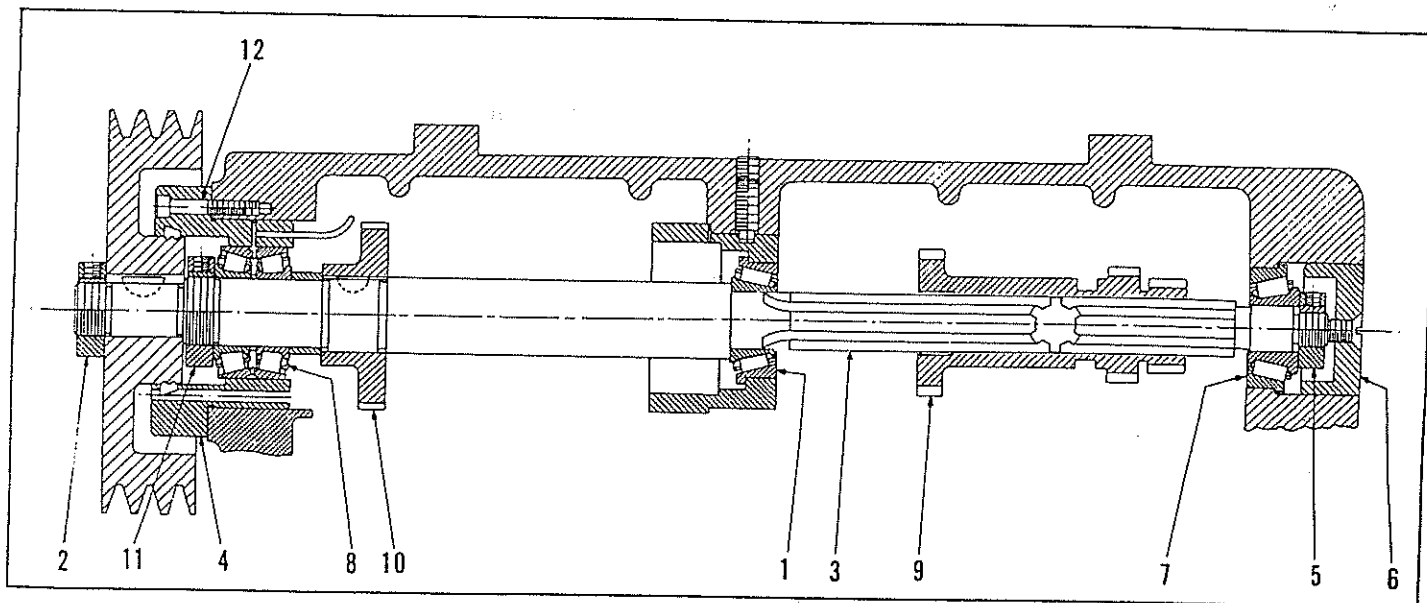

Figure 5-7. Standard Drive Shaft

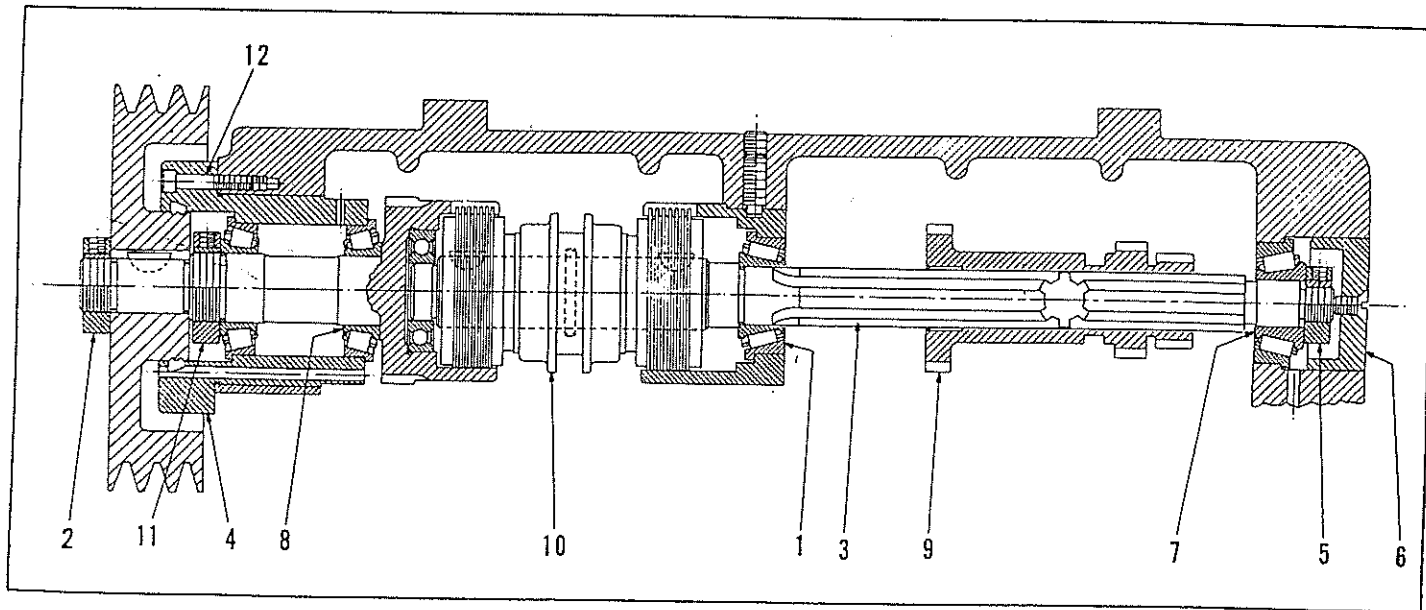

Figure 5-8. Drive Shaft (Clutch Drive)

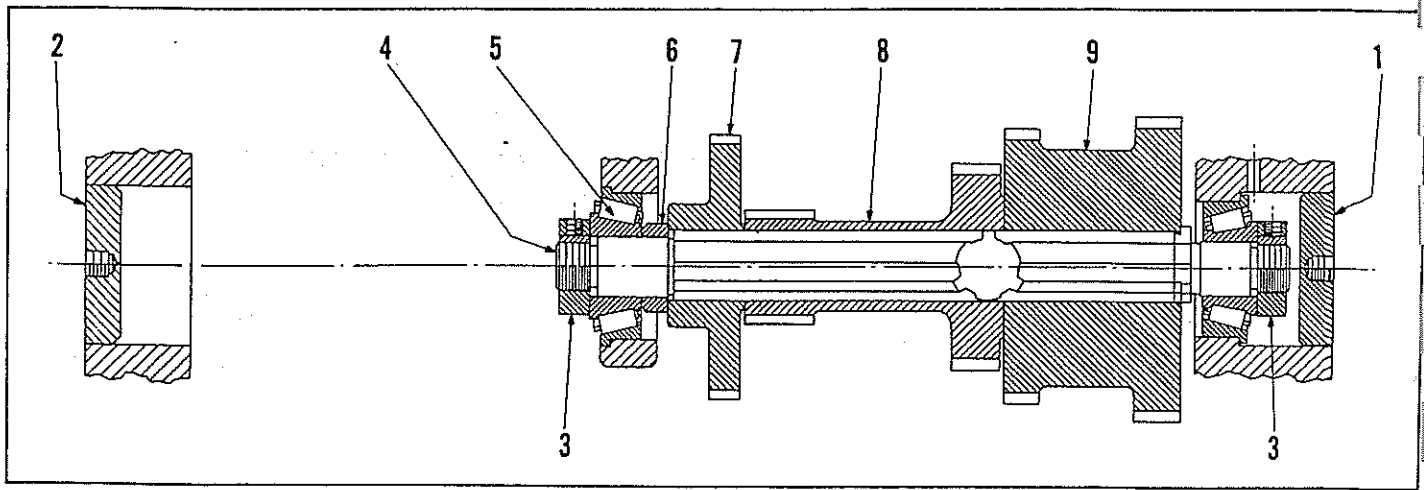

Figure 5-9. Intermediate Shaft

5-33. TO REMOVE INTERMEDIATE SHAFT (See Figure 5-9).

- a. Proceed as described in paragraphs 5-31a thru g, "Standard Drive".
- b. Remove the plugs (1) and (2) in the headstock casting in line with shaft. See paragraph 5-31f for method of removal.
- c. Remove lock nuts (3) from both ends of shaft (4) by loosening set screws and tapping to free lock shoes. Then unscrew nuts.
- d. Using a brass bar, tap intermediate shaft toward spindle nose end of headstock, removing in turn tapered roller bearing cone (5), spacer (6) and primary gears (7, 8 & 9).

5-34. TO REMOVE AND DISMANTLE END GEAR DRIVE SHAFT.

- a. Proceed as described in paragraph 5-28a thru f, "To Remove and Dismantle Speed Shifter Mechanism".
- b. Open door in end gearing guard, and remove end gearing and quadrant. Drain oil from headstock.
- c. Loosen set screw in gear and remove from shaft. Remove four Allen screws from cap.
- d. Loosen set screw in adjusting nut, tap to free shoe, and turn adjusting nut against gear to force shaft toward pulley end of headstock.

NOTE

Be careful not to hit key in shaft under gear.

- e. After shaft is started, tap it from spindle nose end of headstock. Oil seal cap, and bearing will come off pulley end of shaft.
- f. Slide shaft out, removing in turn gear, key and adjusting nut.

5-35. TO REMOVE BACK GEAR SHAFT (See Figure 5-10).

- a. Proceed as described under paragraphs 5-28a thru f, "To Remove and Dismantle Speed Shifter Mechanism".
- b. Remove plug (2) from the headstock casting in line with back gear shaft (3).
- c. To remove lock nut (4), loosen set screw, tap to free lock shoe, and unscrew lock nut from left end of shaft. Remove back gear shaft thrust collar.
- d. Loosen Allen set screw, and use a face spanner wrench to remove back gear screw (5).
- e. Screw a rod with a nut on its outer end into right end of back gear shaft (3), slide a clearance drilled weight along the rod and hammer against the nut until the shaft is drawn out, removing in turn spacer (15), helical gear (6), small spacer (7), sliding back gear (9) and cluster sliding back gear.

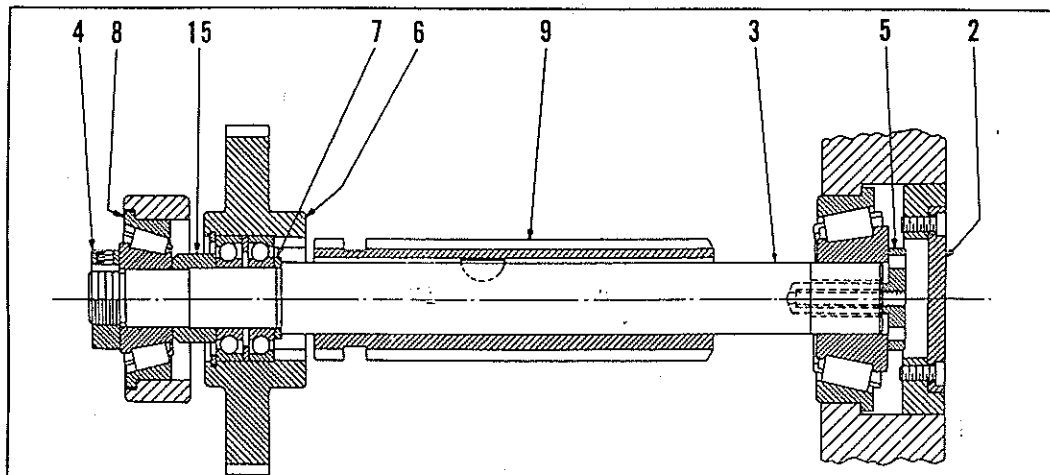

Figure 5-10. Back Gear Shaft

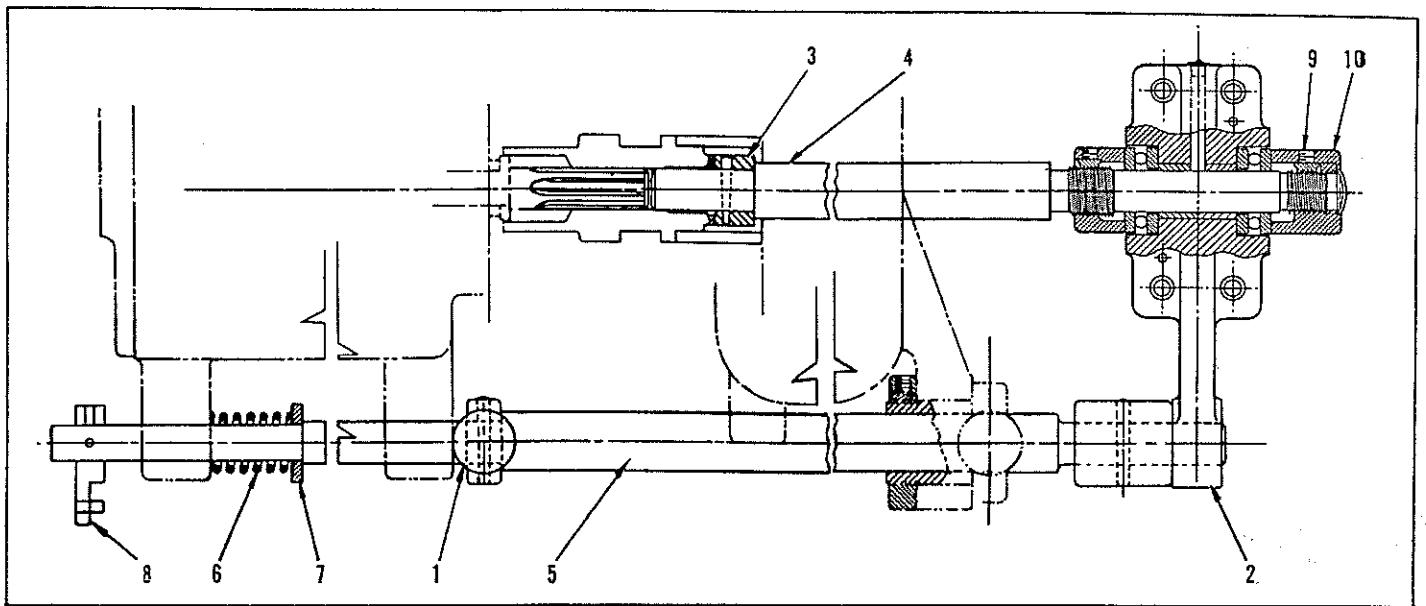

Figure 5-11. Leadscrew and Control Rod

5-36. TO REMOVE AND DISMANTLE LEADSCREW AND CONTROL ROD (See Figure 5-11).

- a. Move carriage to approximate center of bed.
- b. Remove end gearing guard.
- c. Drive out taper pins in control rod lever (8) and control handle (1). Loosen set screw in control rod lever.
- d. Unscrew four socket head screws and tap loose back box (2).
- e. Engage half-nuts and move carriage toward tail-stock end of bed until leadscrew clutch (3) is exposed. Drive out the taper pin and remove clutch.
- f. Release half-nuts and slide out the leadscrew (4) and control rod (5), removing in turn control rod lever (8), spring (6), spring thrust washer (7), and control handle (1) from the control rod.

5-37. TO REMOVE APRON UNIT.

- a. Proceed as per paragraphs 5-36a to f inclusive under "To Remove and Dismantle Leadscrew and Control Rod".
- b. Remove chasing dial.
- c. Unscrew the six socket head screws holding apron to carriage. To prevent dropping apron when the screws are removed another man is required.

5-38. TO REMOVE QUICK CHANGE GEAR BOX.

- a. Proceed as per paragraphs 5-36a to f inclusive under "To Remove and Dismantle Leadscrew and Control Rod", until leadscrew and control rod are clear of quick change gear box.
- b. Unscrew nut and slide off washer, change gear spacer and drive shaft gear.
- c. Unscrew the two nuts locking the quadrant plate in position and remove quadrant plate and idler gear.
- d. Unscrew four socket head screws and remove end cover, including drive shaft and gear.
- e. Unscrew four socket head screws (one located inside casting at end cover end) and remove by tapping quick change box with rubber mallet to break loose from key.

5-39. INSTRUCTIONS FOR INSTALLATION OF TAPER ATTACHMENT ON LATHES IN THE FIELD.

5-40. To facilitate installation of the telescopic taper attachment on lathes in the field, we supply with the attachment when ordered, a completely assembled telescopic cross screw consisting of ball crank handle, locking collar, cross feed dial bush, spring, dial, bush, pinion, telescopic screw and nut with attaching parts. The cross feed screw, which is splined, can be easily removed from the pinion for assembly purposes. The correct method of installing the taper attachment on lathes in the field should be accomplished in the following manner:

- a. Remove the present cross feed screw, including locking collar, ball crank handle, bush, and pinion. This is easily accomplished by removing the four Allen head socket screws holding the bush and then tapping the bush free. The cross feed screw then can be unscrewed thru the cross feed nut.
- b. To remove the cross feed nut, slide the cross slide assembly toward the rear of the machine, and unscrew the cross feed nut screw which fastens the nut to the underside of the cross slide. Remove the chip guard from the rear of the cross slide, push the cross slide toward the front of the machine, exposing the cross feed nut which can now be lifted out.
- c. Break all sharp corners on drawbar. Fit drawbar to dovetail of carriage. Then fit drawbar to dovetail of bracket. Mount the taper attachment bracket on the rear of the carriage, using the holes which have been drilled and tapped at the factory.
- d. When so mounted, place an indicator on the cross slide, and indicate along the bottom of the carriage dovetail. Set indicator on zero and indicate to bottom of bracket dovetail. Tolerance should be plus or minus .001"
- e. Be careful at this point and make sure the drawbar slides freely in the bracket dovetail and the carriage dovetail, with the locking nut removed. Make adjustments as required until it does slide freely, then tighten bolts securely and pin bracket to carriage.
- f. Remove the drawbar and install the new cross feed screw completely assembled with cross feed nut, cross feed screw, bearing bracket, and thrust

washer. This unit should be placed in position from the rear of the lathe. Insert and tighten the screw holding the cross feed nut in position. Slide the drawbar into position and attach to the bearing bracket with the two screws and two straight pins provided. Position the cross slide so that the shoulder screw connecting the drawbar to the taper attachment top slide shoe can be inserted and tightened.

g. Install the ball crank handle and dial assembly, making certain that the internal key of the cross feed pinion aligns with the keyway of the cross feed screw. Fasten this unit in position with the four screws provided for the cross feed bush.

h. Check alignment of the cross feed nut and screw by moving the cross slide to the extreme positions. If binding action occurs at either extreme front or rear positions, loosen and then retighten the screw holding the cross feed nut.

i. As a final check to ascertain whether the gibs on the taper attachment and cross slide are set pro-

perly, tighten the locating clamps of the taper attachment and move the carriage slowly by hand along the bed. It should move freely and evenly. If the gibs are too tight the movement of the cross slide will be jumpy instead of operating smoothly.

j. To check alignment of taper attachment with bed, loosen all nuts and bolts until long slide and swivel bar move freely. Move long slide freely by hand until it finds its own centerline. Position it at extreme left of its traverse. Tighten nut at right end. Slide thru to extreme right position and tighten nut at left end. Slide thru again to see if it slides freely.

k. Set dial indicator on cross slide in position to indicate on tailstock spindle or shaft mounted in chuck. Set indicator on zero as long slide is in extreme left position. Move long slide to extreme right position. Indicator should still be on zero.

Tighten bolt holding drawbar and shoe, then all other nuts and set pointers at each end on zero.

See following pages for Wiring Diagrams

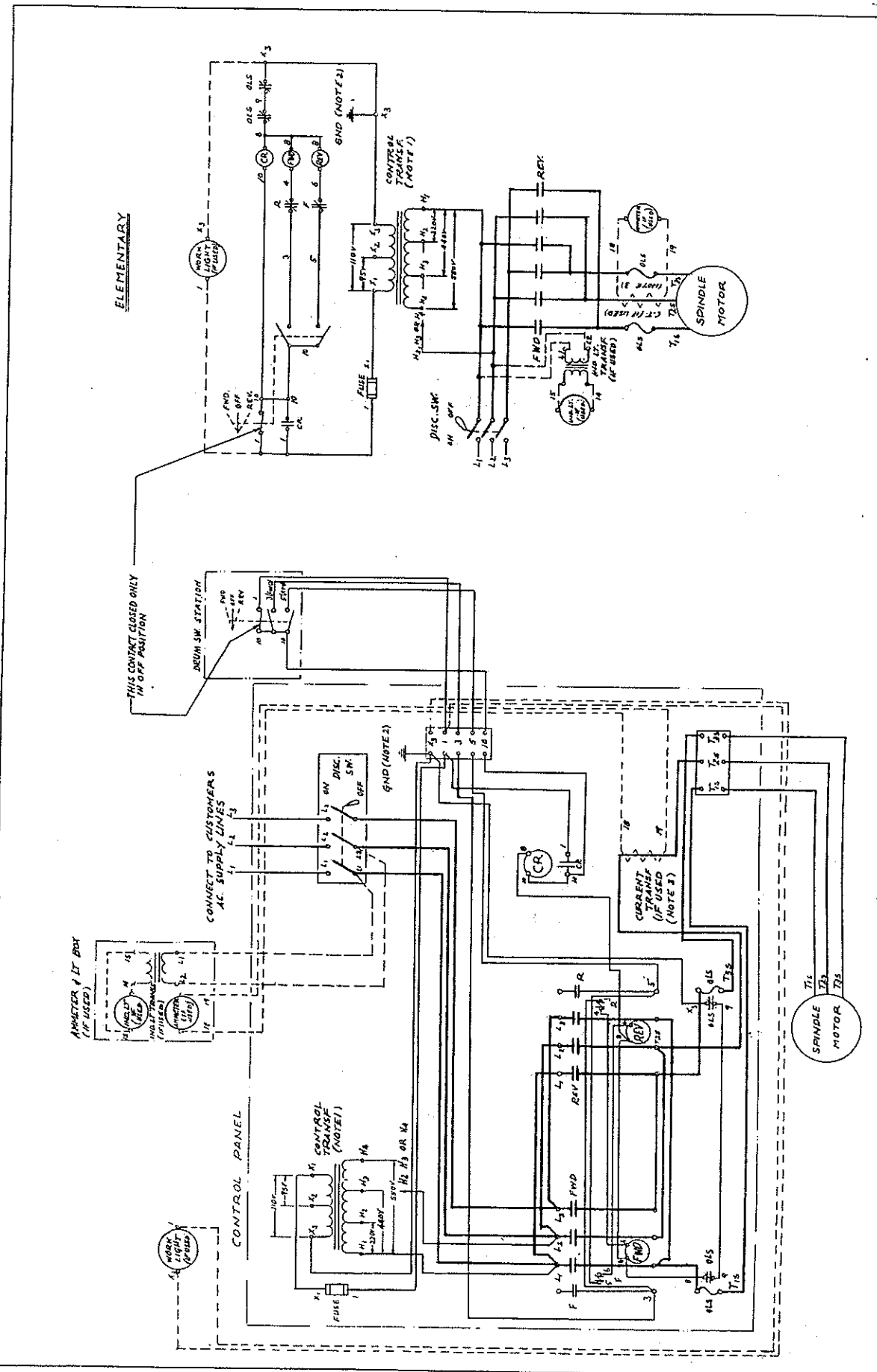

ELEMENTARY

WIRING DIAGRAM

3710 GRADIENT CONTROL

WBS COMPANY

1000 W. 10TH ST. CINCINNATI, OHIO

DATE: 10/15/58

BY: J. W. B. / J. W. B.

APPROVED BY: J. W. B.

603721

CINCINNATI LATHÉ & TOOL CO.

INCORPORATED IN OHIO, U.S.A.

NOTE 1 - FOR TRANSFORMER WITH DUAL VOLTAGE PRIMARY WITH 230 VOLT SUPPLY - CONNECT M₁ & M₃ TO L₁; M₂ & M₄ TO L₂ WITH 440 VOLT SUPPLY - CONNECT M₁ TO L₁; M₂ TO L₂; M₃ TO M₄

NOTE 2 - TO BE GROUNDED BY PURCHASER IF CONDITIONS PERMIT

NOTE 3 - CURRENT TRANSFORMER FOR MOTOR LOAD PER CENT AMMETER MUST BE CALIBRATED ACCORDING TO FULL LOAD AMPERES SHOWN ON MOTOR NAME PLATE. IF A CALIBRATED SELF CONTAINED AMMETER ONLY IS USED CONNECT IN SERIES WITH T₂

NOTE - FOR 3 PHASE SWIRE SERVICE L₁, L₂ & L₃ ARE THE COMMON.

ELEMENTARY

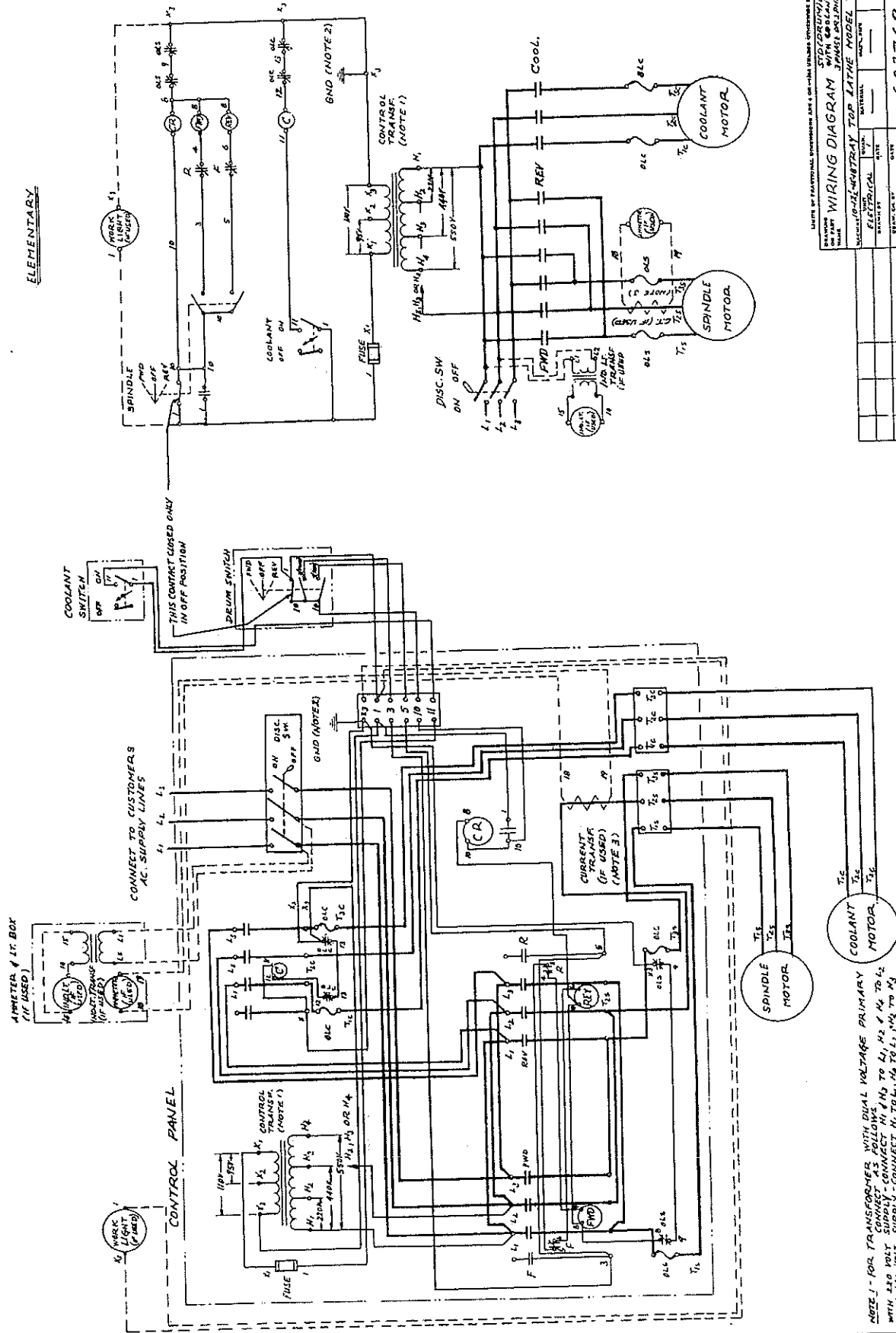

NOTE: IF PRACTICAL, DIMENSIONS ARE IN INCH UNLESS OTHERWISE SPECIFIED.

STANDARD CONTROL WIRING DIAGRAM WITH 600 VOLT WIRE

WIRING DIAGRAM FOR LATHE MODEL 1 E.

DATE	BY	REVISION	BY
10/15/54	W. R. R.	1	W. R. R.
10/15/54	W. R. R.	2	W. R. R.
10/15/54	W. R. R.	3	W. R. R.
10/15/54	W. R. R.	4	W. R. R.
10/15/54	W. R. R.	5	W. R. R.
10/15/54	W. R. R.	6	W. R. R.
10/15/54	W. R. R.	7	W. R. R.
10/15/54	W. R. R.	8	W. R. R.
10/15/54	W. R. R.	9	W. R. R.
10/15/54	W. R. R.	10	W. R. R.

603769

CINCINNATI LATHE & TOOL CO.
CINCINNATI, OHIO, U.S.A.

NOTE - FOR 2 PHASE 3 WIRE SERVICE L2 & T2 ARE THE COMMON.

NOTE 3 - CURRENT TRANSFORMER FOR MOTOR LOAD PER CENT AMMETER MUST BE CALIBRATED TO MOTOR NAME PLATE. IF NOT, SELF CONTAINED AMMETER ONLY'S USED CONNECT IN SERIES WITH T2'S.

NOTE 1 - FOR TRANSFORMER WITH DUAL VOLTAGE PRIMARY WITH 250 VOLT CONNECT H1, H2 TO L1, H3 TO L2, H4 TO L3. WITH 480 VOLT SUPPLY - CONNECT H1, H2 TO L1, H3 TO L2, H4 TO L3.

NOTE 2 - TO BE GROUNDED BY PURCHASER IF CONVENTIONAL PERMIT

ELEMENTARY

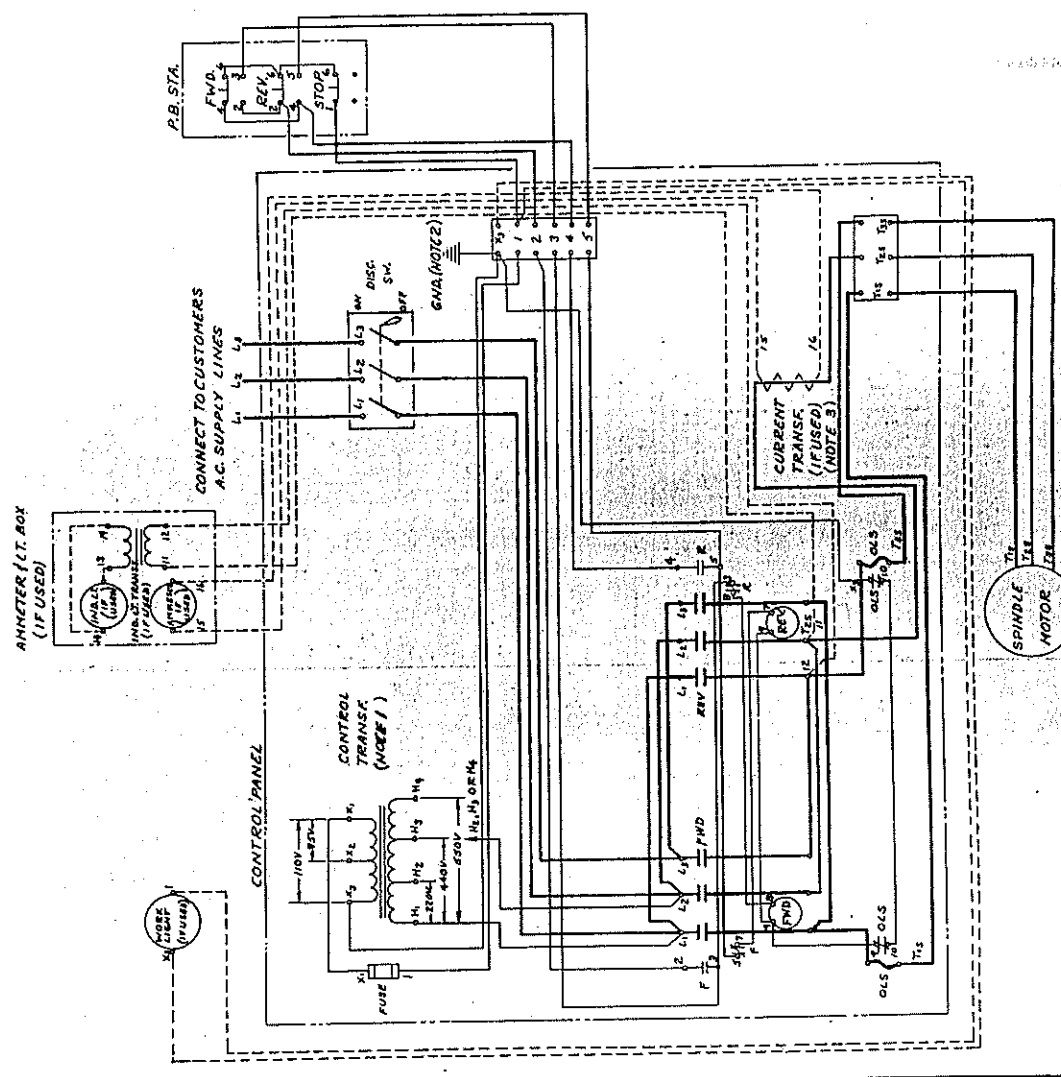
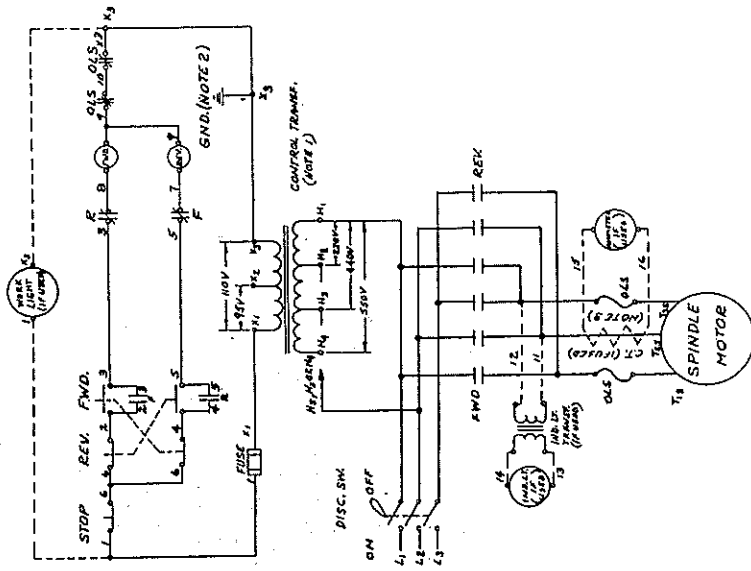

NOTE - FOR 2 PHASE 3 WIRE SERVICE USE 42 & 72 ARE THE CORRECT
 LINES OF TERMINATION. CONSULT TABLE 1 ON THE INSIDE OF THE CONTROL PANEL.

WIRING DIAGRAM
 MODEL 10-12315-18 TRAY-TOP MODEL 10-12315-18
 DATE: 12-15-56
 MATERIAL: 603770
 DRAWN BY: J. W. B. / DATE: 12-15-56
 CHECKED BY: J. W. B. / DATE: 12-15-56
 APPROVED BY: J. W. B. / DATE: 12-15-56
 CINCINNATI LATHES & TOOL CO.
 CINCINNATI 5, OHIO, U.S.A.

NOTE 3 - CT TRANSF. FOR MOTOR LOAD PER CENT. AMMETER MUST BE CALIBRATED ACCORDING TO FULL LOAD AMPERES SHOWN ON MOTOR NAME PLATE. IF A CALIBRATED SELF-CORRECTING AMMETER ONLY IS USED CONNECT IN SERIES WITH T-5.

NOTE 2 - TO BE GROUNDED BY PURCHASER IF CONDITIONS PERMIT.

NOTE 1 - FOR TRANSFORMERS WITH DUAL VOLTAGE PRIMARY CONNECT AS FOLLOWS:
 WITH 220 VOLT SUPPLY - CONNECT H₁, H₂ TO L₁, H₃, H₄ TO L₂
 WITH 440 VOLT SUPPLY - CONNECT H₁, H₂, H₃ TO L₁, H₄ TO L₂

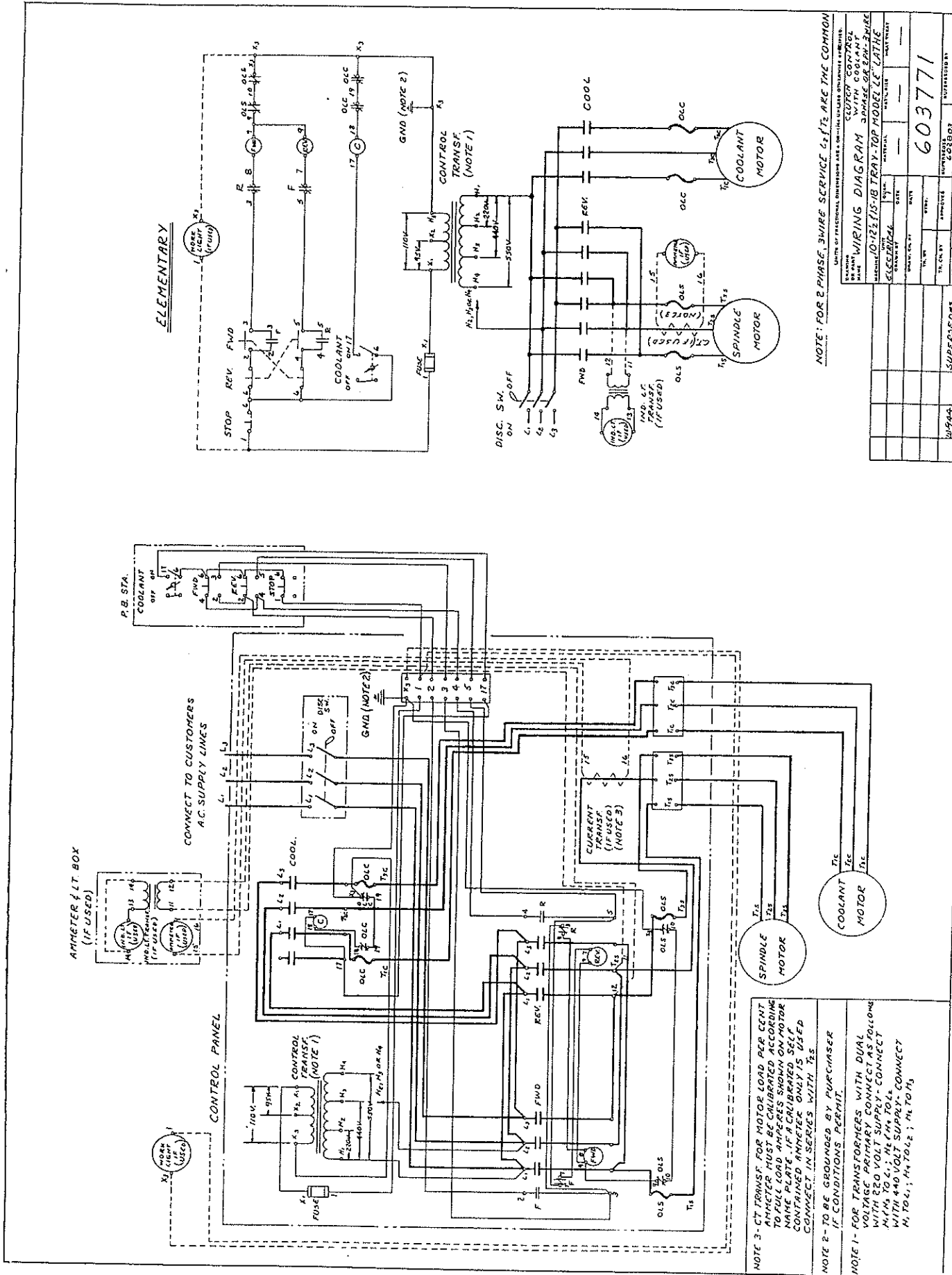

WIRING DIAGRAM WITH COOLANT PUMP FOR 10-1821-15-18 TRAY-TOP MODEL LE LATHE

ORDER BY: DATE: MADE BY: PART NO.:

APPROVED BY: DATE: MADE BY: PART NO.:

TECHNICAL SUPERVISOR: DATE: MADE BY: PART NO.:

603771

CINCINNATI, OHIO, U.S.A.

SECTION VI

PARTS LIST

FOR

CINCINNATI TRAY-TOP
MODEL LE
ENGINE AND TOOLROOM LATHES

SIZES - 10", 12-1/2", 15" AND 18"

AND

CINCINNATI TRAY-TOP
MODEL LE
FIXED GAP BED LATHES

SIZES - 15" AND 18"

INTRODUCTION

This parts list has been prepared for your assistance in ordering replacement parts for the above machines.

The group assembly parts listings are divided into five columns. The first column indicates the figure and index number of the part. The figure number indicates the illustration on which the part is shown. The index number is keyed to the part for identification purposes. The second column contains the Cincinnati Lathe and Tool Co. part number. The third column contains the complete name of the part. The fourth column contains the number of parts required for the assembly. The last, or right-hand column, contains the application code, indicating production usage of parts between the two sizes of lathes covered by this parts list.

Code	Size of Lathe
A	10"
B	12-1/2"
C	15"
D	18"

Electrical equipment parts for these machines are not shown. Contact the local representative of the electrical manufacturer for servicing and maintenance of his equipment.

ORDERING REPAIR PARTS

You will receive quicker service when ordering repair parts if you will proceed as follows:

1. State amount wanted.
2. Give part number stamped on part, or shown in the parts list, specifying where you obtained the number.
3. Give complete serial number of the machine. The serial number is stamped between the front flat and vee way at the tailstock end of the bed.
4. Give complete size of machine, i.e. (15" x 72" Cincinnati Tray-Top Lathe).
5. Specify each individual part required. Never use the term "complete assembly", it always raises the question of how much of a unit to supply.
6. State how and where to ship. Do not say "ship quickest way". Be definite and state the agency desired, that is Air Parcel Post, Special Delivery, Railway Express, Motor Freight, etc. Give complete destination.

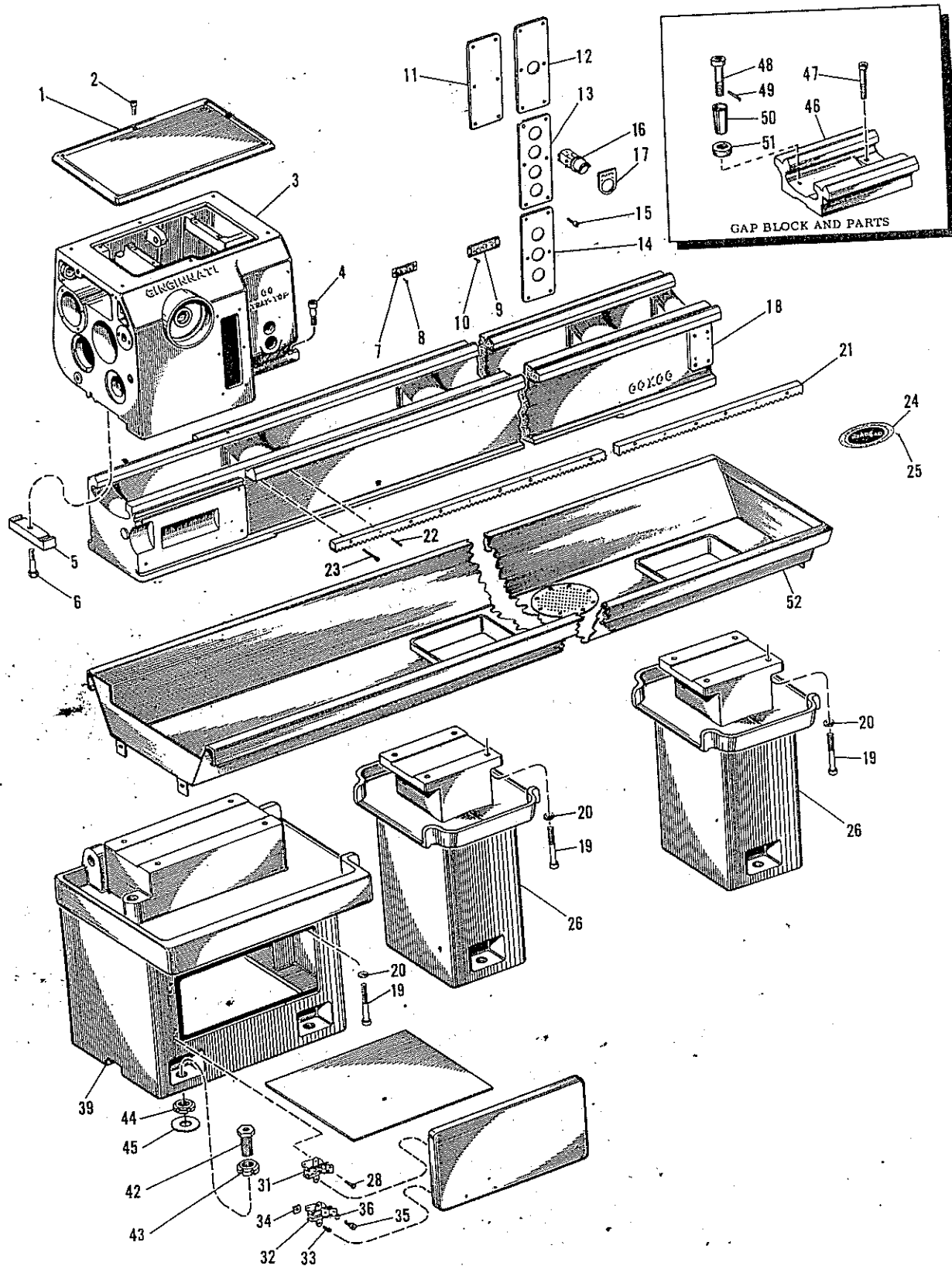

Figure 1. General Assembly

Figure and Index No.	Part No.	Nomenclature							Units Per Assy	Application Code
		1	2	3	4	5	6	7		
GENERAL ASSEMBLY (SEE FIGURE 1)										
1-1	604745	.							1	AB
-1	604065	.							1	CD
		Attaching Parts								
-2	3399	.							8	All
		-----*								
-3	604743	.							1	A
-3	604744	.							1	B
-3	604117	.							1	C
-3	604118	.							1	D
		Attaching Parts								
-4	3405	.							2	AB
-4	1925	.							2	CD
		-----*								
-5	600756	.							1	A
-5	600757	.							1	B
-5	600244	.							1	C
-5	604047	.							1	D
		Attaching Parts								
-6	3429	.							1	AB
-6	610	.							1	CD
		-----*								
-7	604018	.							1	CD
		Attaching Parts								
-8	3178	.							2	CD
		-----*								
-9	604702	.							1	AB
-9	605003	.							1	CD
		Attaching Parts								
-10	3178	.							4	All
		-----*								
-11	603725	.							1	AB
-11	602933	.							1	CD
-12	603726	.							1	AB
-12	602934	.							1	CD
-13	603729	.							1	AB
-13	602937	.							1	CD
-14	603728	.							1	AB
-14	602936	.							1	CD
		Attaching Parts								
-15	3198	.							6	All
		-----*								
-16	141505-A	.							1	All
-16	141513-A	.							2	All
		clutch drive only								
-16	141513-G	.							1	All
-17	603062-A	.							1	All
-17	141252-G	.							1	All
-17	141252-H	.							1	All
-17	141252-B	.							1	All
-18	605471	.							1	A
-18	605474	.							1	A
-18	605475	.							1	B
-18	605477	.							1	B
-18	605442	.							1	C
-18	605444	.							1	C
-18	605446	.							1	C
-18	605448	.							1	C
-18	605450	.							1	D
-18	605452	.							1	D
-18	605454	.							1	D
-18	605456	.							1	D

Figure and Index No.	Part No.	Nomenclature							Unit Per Assy	Application Code
		1	2	3	4	5	6	7		
GENERAL ASSEMBLY (SEE FIGURE 1) (CONT'D)										
Attaching Parts										
1-19	3248								8	AB
-20	2038								8	AB
-19	3268								8	CD
-20	2118								8	CD
										} 4 Additional with Center Leg
										* -----
-21	600035								1	AB
-21	603421								1	CD
Attaching Parts										
-22	663								AR	AB
-22	83800								AR	CD
-23	3227								AR	AB
-23	3400								AR	CD
-24	605012								1	All
Attaching Parts										
-25	3178								4	All
										* -----
-26	605431								1	A
-26	605432								1	B
-26	605433								1	C
-26	605434								1	D
Attaching Parts										
-27	Delete									
-28	3218								4	All
-29	Delete									
-30	Delete									
-31	604446								1	All
-32	604445								1	All
-33	605065								4	All
-34	605064								4	All
-35	106033								2	All
-36	108161								2	All
										* -----
-37	Delete									
-38	Delete									
-39	604629								1	A
-39	604630								1	B
-39	604239								1	C
-39	604240								1	C
-39	604243								1	D
-39	604244								1	D
-40	604633								1	AB
-40	604437								1	CD
-41	604635								1	AB
-41	604444								1	C
-41	604441								1	D
-42	113157								AR	All
-43	127579								AR	All
-44	3792								AR	All
-45	219948								AR	All
-46	603910								1	C
-46	603909								1	D
Attaching Parts										
-47	3248								2	CD
										* -----
-48	605113								2	C
-48	605114								2	D
-49	3285								2	CD
-50	603419								2	C
-50	604873								2	D
-51	2143								2	CD
										* -----
-52										Pan (See Figure 23 for parts)

Figure and Index No.	Part No.	Nomenclature	Units							Application Code
			Per	Assy						
HEADSTOCK SPINDLE ASSEMBLY ("A" SHAFT) (SEE FIGURE 2)										
2-1	607368	. Pinion - End gearing						1	AB	
-1	607388	. Pinion - End gearing						1	CD	
		Attaching Parts								
-2	3229	. Screw - Hex socket dog point set						1	AB	
-2	3230	. Screw - Hex socket dog point set						1	CD	
-3	3472	. Nut - Hex thin						1	All	
		- - - - - * - - - - -								
-4	864	. Key - Square						1	AB	
-4	3307	. Key - Square						1	CD	
-5	604802	. Cap - Rear bearing						1	AB	
-5	605109	. Cap - Rear bearing						1	CD	
-6	4195	. Nut - Lock						1	AB	
-6	4255	. Nut - Lock						1	CD	
-7	604475	. Washer						1	CD	
-8	604760	. Bearing - Rear						1	AB	
-8	604016	. Bearing - Rear						1	CD	
-9	604796	. Adapter - Bearing						1	AB	
-9	604019	. Adapter - Bearing						1	CD	
-10	604769	. Gear - Helical						1	AB	
-10	604027	. Gear - Helical						1	CD	
-11	3307	. Key - Square						1	AB	
-11	3448	. Key - Square						1	CD	
-12	4197	. Nut - Lock						1	AB	
-12	604088	. Nut - Lock						1	CD	
-13	604812	. Key - "A" Shaft						1	AB	
-13	604350	. Key - "A" Shaft						1	CD	
-14	604799	. Bearing - Regular						1	AB	
-14	604100	. Bearing - Regular						1	CD	
-14	604800	. Bearing - Tool room						1	AB	
-14	604101	. Bearing - Tool room						1	CD	
-15	4255	. Nut - Lock						1	AB	
-15	4259	. Nut - Lock						1	CD	
-16	604776	. Gear - "A" Shaft						1	AB	
-16	604037	. Gear - "A" Shaft						1	CD	
-17	965	. Key - Square						1	AB	
-17	3450	. Key - Square						1	CD	
-18	604797	. Bearing - Regular						1	AB	
-18	604098	. Bearing - Regular						1	CD	
-18	604798	. Bearing - Tool room						1	AB	
-18	604099	. Bearing - Tool room						1	CD	
-19	604795	. Slinger - Oil - "A" Shaft						1	AB	
-19	604094	. Slinger - Oil - "A" Shaft						1	CD	
-20	604770	. Cap - Front bearing - "A" Shaft (L00)						1	AB	
-20	604858	. Cap - Front bearing - "A" Shaft (L0 D1-3 D1-4)						1	CD	
-20	604097	. Cap - Front bearing - "A" Shaft						1	AB	
-20	604859	. Cap - Front bearing - "A" Shaft						1	CD	
		Attaching Parts								
-21	3203	. Screw - Low socket head cap						4	All	
		- - - - - * - - - - -								
-22	604793	. Nut - Spindle (L0)						1	All	
-22	604830	. Nut - Spindle (L00)						1	AB	
-22	603277	. Nut - Spindle (L1)						1	CD	
-23	604777	. Spindle - "A" Shaft (L0 Taper nose)						1	AB	
-23	604778	. Spindle - "A" Shaft (L00 Taper nose)						1	CD	
-23	604038	. Spindle - "A" Shaft (L1 Taper nose)						1	AB	
-23	604039	. Spindle - "A" Shaft (L0 Taper nose)						1	CD	
-24	600203	. Key - Spindle (L0 Taper nose)						1	All	
-24	600803	. Key - Spindle (L00 Taper nose)						1	AB	
-24	602268	. Key - Spindle (L1 Taper nose)						1	CD	

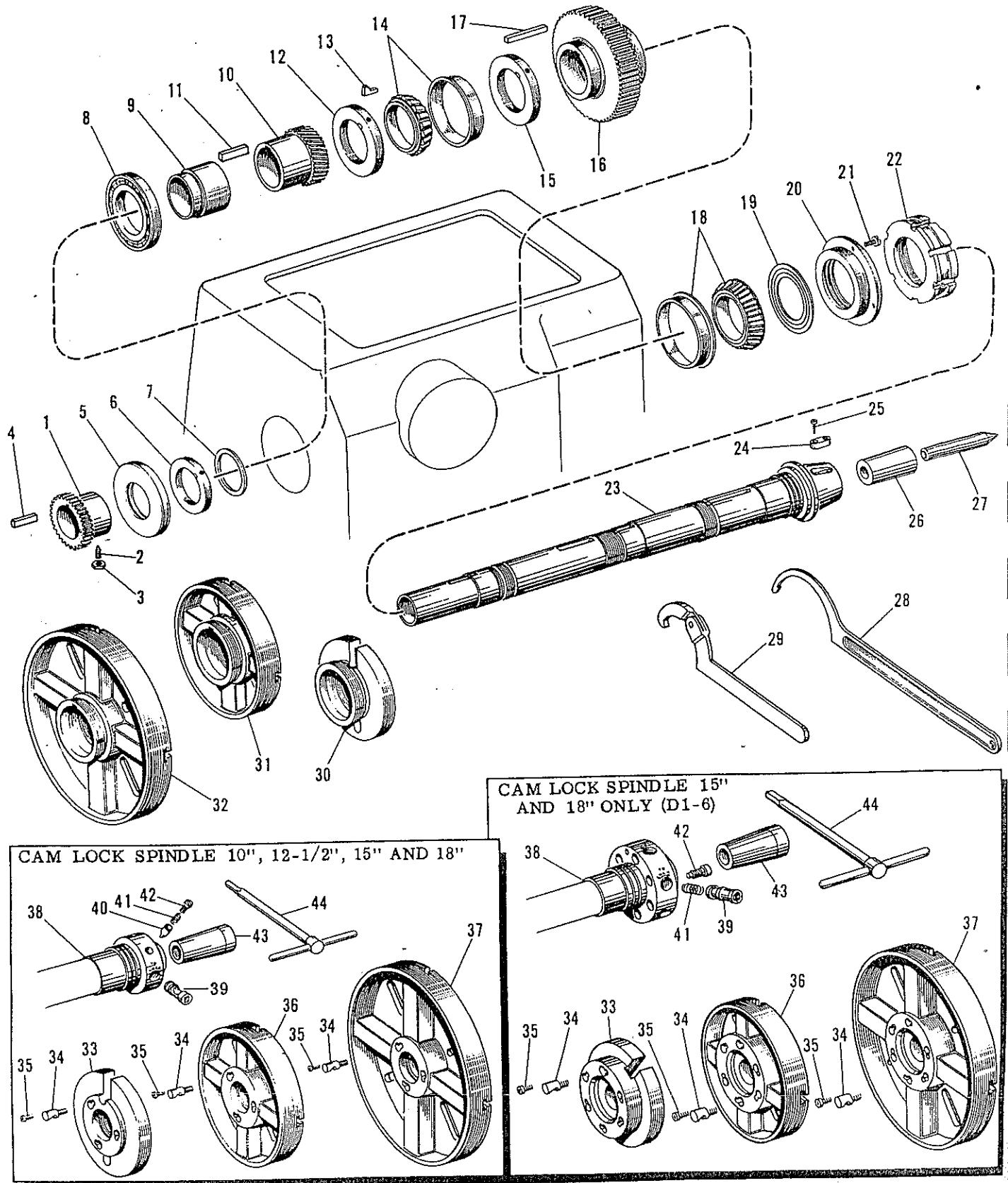

Figure 2. Headstock Spindle Assembly ("A" Shaft)

Figure and Index No.	Part No.	Nomenclature	Units Per Assy	Application Code
HEADSTOCK SPINDLE ASSEMBLY ("A" SHAFT) (SEE FIGURE 2) (CONT'D)				
Attaching Parts				
2-25	3194	. Screw - Socket head cap	2	All
-25	124975	. Screw - Socket head cap	2	CD
-----*				
-26	600760	. Sleeve - Center - L00 Spindle	1	A
-26	603957	. Sleeve - Center - L00 Spindle	1	B
-26	604806	. Sleeve - Center - L0 Spindle	1	A
-26	600243	. Sleeve - Center - L0 Spindle	1	BC
-26	603958	. Sleeve - Center - L0 Spindle	1	D
-26	604015	. Sleeve - Center - L1 Spindle	1	C
-26	602269	. Sleeve - Center - L1 Spindle	1	D
-27	603952	. Center - #2 Morse taper	1	A
-27	600242	. Center - #3 Morse taper	1	BC
-27	601373	. Center - #4 Morse taper	1	D
-28	602943	. Wrench - Spanner - L00 Spindle	1	AB
-28	602357	. Wrench - Spanner - L1 Spindle	1	CD
-29	600966	. Wrench - Adjustable hook spanner - L0 Spindle	1	All
-30	604763	. Plate - Dog (L0 Spindle)	1	AB
-30	604764	. Plate - Dog (L00 Spindle)	1	AB
-30	604453	. Plate - Dog (L0 Spindle)	1	CD
-30	604367	. Plate - Dog (L1 Spindle)	1	CD
-31	600759	. Plate - Face (L00 Spindle)	1	A
-31	603988	. Plate - Face (L00 Spindle)	1	B
-31	604758	. Plate - Face (L0 Spindle)	1	B
-31	604759	. Plate - Face (L0 Spindle)	1	A
-31	600510	. Plate - Face (L0 Spindle)	1	C
-31	603992	. Plate - Face (L0 Spindle)	1	D
-31	601296	. Plate - Face (L0 Spindle) Gap	1	G
-31	603993	. Plate - Face (L0 Spindle) Gap	1	D
-31	604364	. Plate - Face (L1 Spindle)	1	C
-31	602523	. Plate - Face (L1 Spindle) Gap	1	C
-31	604036	. Plate - Face (L1 Spindle)	1	D
-32	604365	. Plate - Face (L1 Spindle) Gap	1	D
-33	604765	. Plate - Dog - Cam lock (D1-3 Spindle)	1	AB
-33	604773	. Plate - Dog - Cam lock (D1-4 Spindle)	1	AB
-33	604452	. Plate - Dog - Cam lock (D1-4 Spindle)	1	CD
-33	604370	. Plate - Dog - Cam lock (D1-6 Spindle)	1	CD
Attaching Parts				
-34	601618	. Stud - Cam lock (D1-3)	3	AB
-34	601626	. Stud - Cam lock (D1-4)	3	All
-34	603693	. Stud - Cam lock (D1-6)	6	CD
-35	3218	. Screw - Cam lock (D1-3 & 4)	3	All
-35	2319	. Screw - Cam lock (D1-6)	6	CD
-----*				
-36	604761	. Plate - Face - Cam lock (D1-4 Spindle)	1	A
-36	604762	. Plate - Face - Cam lock (D1-4 Spindle)	1	B
-36	601616	. Plate - Face - Cam lock (D1-3 Spindle)	1	A
-36	603989	. Plate - Face - Cam lock (D1-3 Spindle)	1	B
-36	601624	. Plate - Face - Cam lock (D1-4 Spindle)	1	C
-36	603994	. Plate - Face - Cam lock (D1-4 Spindle)	1	D
-36	604115	. Plate - Face - Cam lock (D1-6 Spindle)	1	C
-36	604369	. Plate - Face - Cam lock (D1-6 Spindle)	1	D
-36	604359	. Plate - Face - Cam lock (D1-6 Spindle) - Gap	1	C
-37	604366	. Plate - Face - Cam lock (D1-4 Spindle) - Gap	1	C
-37	603995	. Plate - Face - Cam lock (D1-4 Spindle) - Gap	1	D
-37	604368	. Plate - Face - Cam lock (D1-6 Spindle) - Gap	1	D
-38	604780	. Spindle - "A" Shaft - Cam lock D1-3	1	AB
-38	604779	. Spindle - "A" Shaft - Cam lock D1-4	1	AB
-38	604040	. Spindle - "A" Shaft - Cam lock D1-4	1	CD
-38	604041	. Spindle - "A" Shaft - Cam lock D1-6	1	CD
-39	601614	. Cam - D1-3 Spindle nose	3	AB
-39	604363	. Cam - D1-4 Spindle nose	3	All
-39	603692	. Cam - D1-6 Spindle nose	6	CD
-40	604362	. Plunger - Spindle nose detent (D1-3 & 4)	3	All
-41	718	. Spring - Spindle nose detent (D1-3 & 4)	3	All
-41	603691	. Spring - Spindle nose detent (D1-6)	6	CD

Figure and Index No.	Part No.	Nomenclature							Units Per Assy	Application Code
HEADSTOCK SPINDLE ASSEMBLY ("A" SHAFT) (SEE FIGURE 2) (CONT'D)										
2-42	601613	.							3	AB
-42	2320	.							3	All
-42	603690	.							6	CD
-43	604783	.							1	A
-43	603960	.							1	B
-43	604782	.							1	A
-43	604283	.							1	BC
-43	603961	.							1	D
-43	604357	.							1	D
-43	604116	.							1	C
-44	602711	.							1	AB
-44	602692	.							1	All
-44	611070	.							1	CD

Figure and Index No.	Part No.	Nomenclature							Units Per Assy	Application Code
HEADSTOCK - "B" & "C" SHAFT ASSEMBLIES (SEE FIGURE 3)										
3-1	607404	.							1	CD
-2	235503	.							1	CD
-3	201184	.							1	CD
-4	604042	.							1	CD
-5	703074	.							1	CD
-6	604028	.							1	CD
		Attaching Parts								
-7	3448	.							1	CD
-8	2356	.							1	CD
-9	3232	.							1	CD
		----- * -----								
-10	604025	.							1	CD
-11	70656	.							1	CD
-12	110202	.							1	CD
-13	604092	.							1	CD
-13	604746	.							1	AB
		Attaching Parts								
-14	3203	.							3	All
		----- * -----								
-15	271264	.							1	All
-16	604768	.							1	AB
-17	604781	.							1	AB
-18	57267	.							1	AB
-19	604747	.							1	AB
-20	604750	.							1	AB
-21	604751	.							1	AB
-22	604749	.							1	AB
-23	604767	.							1	AB
-24	963	.							1	AB
-25	604801	.							1	AB
-26	3805	.							1	AB
-27	3806	.							1	CD
-28	607404	.							1	CD
-29	604058	.							1	CD
-30	604471	.							1	CD
-31	238243	.							1	CD
-32	601220	.							2	CD
-33	600221	.							1	CD
-34	600220	.							1	CD
-35	604031	.							1	CD
-36	604030	.							1	CD
-37	3280	.							1	CD
-38	604026	.							1	CD
-39	604029	.							1	CD

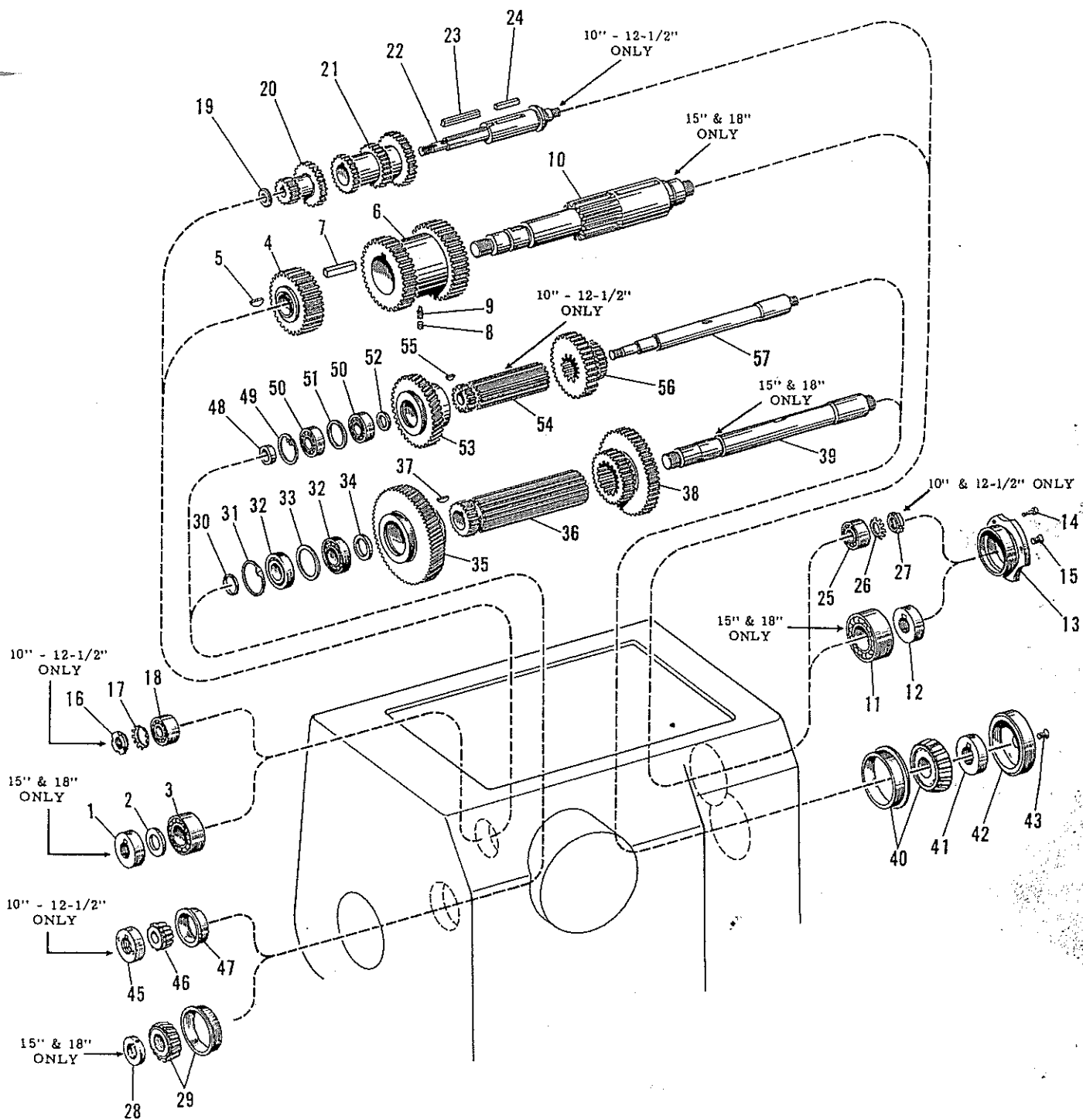

Figure 3. Headstock - "B" & "C" Shaft Assemblies

Figure and Index No.	Part No.	1	2	3	4	5	6	7	Nomenclature	Units Per Assy	Application Code
HEADSTOCK - "B" & "C" SHAFT ASSEMBLIES (SEE FIGURE 3) (CONT'D)											
3-40	604813	.							Bearing - Roller	1	AB
-40	604109	.							Bearing - Roller	1	CD
-41	4184	.							Nut - Lock	1	AB
-41	607405	.							Nut - Lock	1	CD
-42	604789	.							Plug - "B" Shaft	1	AB
-42	604111	.							Plug - "B" Shaft	1	CD
-43	218125	.							Screw - Flat head machine	1	All

Figure and Index No.	Part No.	1	2	3	4	5	6	7	Nomenclature	Units Per Assy	Application Code
HEADSTOCK - "B" & "C" SHAFT ASSEMBLIES (SEE FIGURE 3) (CONT'D)											
3-44	Delete										
-45	605410								Nut - Adj. Lock	1	AB
-46	94233								Cone - Roller bearing	1	AB
-47	202877								Cup - Roller bearing	1	AB
-48	600821								Spacer - "B" Shaft	1	AB
-49	240206								Ring - Retaining internal snap	1	AB
-50	221105								Bearing - Ball	2	AB
-51	600820								Spacer - Bearing	1	AB
-52	600818								Spacer - "B" Shaft	1	AB
-53	604771								Gear - Helical, "B" Shaft	1	AB
-54	604755								Gear - Sliding, "B" Shaft	1	AB
-55	3279								Key - Woodruff	1	AB
-56	604754								Gear - Cluster sliding	1	AB
-57	604756								Shaft - "B"	1	AB

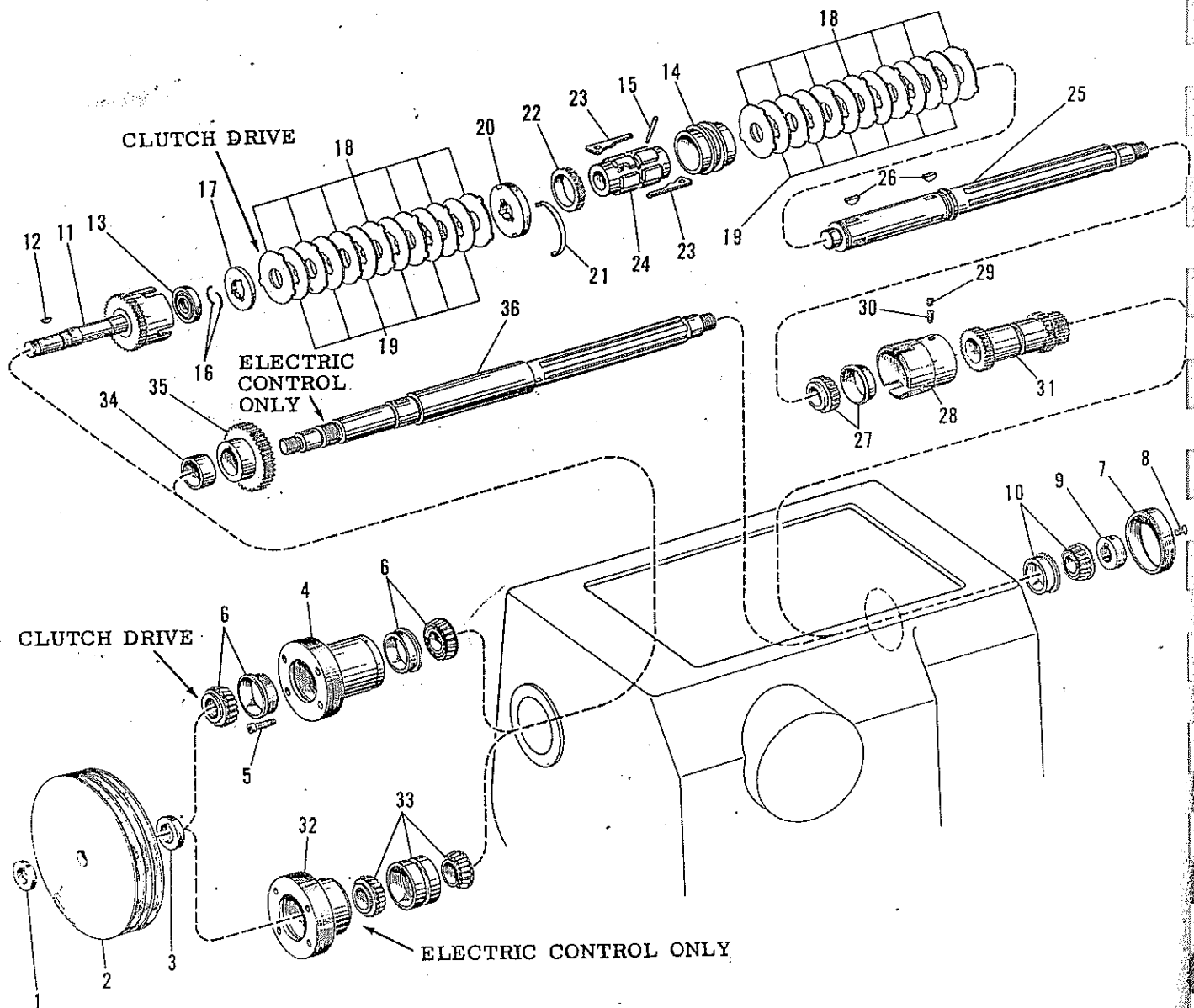

Figure 4. Headstock - Drive Shaft Assembly

Figure and Index No.	Part No.	Nomenclature	Units Per Assy.	Application Code
HEADSTOCK - DRIVE SHAFT ASSEMBLY (SEE FIGURE 4)				
4-1	4241	. Nut - Lock	1	All
-2	604792	. Pulley - Drive Shaft	1	AB
-2	604416	. Pulley - Drive Shaft	1	CD
-3	4186	. Nut - Lock	1	AB
-3	4245	. Nut - Lock	1	CD
-4	604803	. Cap - Drive shaft bearing, "D" Shaft	1	AB
-4	605106	. Cap - Drive shaft bearing, "D" Shaft	1	CD
Attaching Parts				
-5	3400	. Screw - Socket head cap	4	AB
-5	3401	. Screw - Socket head cap	4	CD
----- *				
-6	108345	. Cone - Roller bearing	2	AB
-6	202877	. Cup - Roller bearing	2	AB
-6	604023	. Bearing - Roller	2	CD
-7	604789	. Plug - "D" Shaft	1	AB
-7	604093	. Plug - "D" Shaft	1	CD
-8	218125	. Screw - Flat head machine	1	All
-9	110202	. Nut - Lock	2	AB
-9	607404	. Nut - Lock	1	CD
-10	72209	. Cone - Roller bearing	1	AB
-10	72208	. Cup - Roller bearing	1	AB
-10	604474	. Bearing - Roller	1	CD
-11	604784	. Shaft - Drive clutch	1	AB
-11	604035	. Shaft - Drive clutch	1	CD
-12	3280	. Key - Hi-pro	1	All
-13	604787	. Bearing - "D" Shaft	1	AB
-13	604089	. Bearing - "D" Shaft	1	CD
-14	604788	. Sleeve - Slipper clutch pullmore "D" Shaft	1	AB
-14	604021	. Clutch - Pullmore "D" Shaft	1	CD
Attaching Parts				
-15	603933	. Pin - Anchor	1	AB
-15	702046	. Pin - Anchor	1	CD
----- *				
-16	603941	. Ring - Split	2	AB
-16	603949	. Ring - Split	2	CD
-17	603940	. Plate - Thrust	2	AB
-17	603948	. Plate - Thrust	2	CD
-18	603938	. Disc - Outer	16	AB
-18	603946	. Disc - Outer	14	CD
-19	603939	. Disc - Inner	14	AB
-19	603947	. Disc - Inner	12	CD
-20	603937	. Plate - Pressure	2	AB
-20	603945	. Plate - Pressure	2	CD
-21	603936	. Spring - Adjustment lock	2	AB
-21	702055	. Spring - Adjustment lock	2	CD
-22	603935	. Collar - Adjustment	2	AB
-22	702054	. Collar - Adjustment	2	CD
-23	603934	. Dog	6	AB
-23	702066	. Dog	6	CD
-24	603931	. Body - Clutch	1	AB
-24	603943	. Body - Clutch	1	CD
-25	604785	. Shaft - Drive	1	AB
-25	604032	. Shaft - Drive	1	CD
-26	601840	. Key - Hi-pro	6	AB
-26	603950	. Key - Hi-pro	6	CD
-27	72197	. Cone - Bearing	1	AB
-27	108004	. Cup - Bearing	1	CD
-27	604020	. Bearing - Roller	1	AB
-28	604786	. Cup - Clutch	1	AB
-28	604096	. Cup - Clutch	1	CD
Attaching Parts				
-29	2356	. Screw - Hex socket flat point set	1	AB

Figure and Index No.	Part No.	1	2	3	4	5	6	7	Nomenclature	Units Per Assy	Application Code
HEADSTOCK - DRIVE SHAFT ASSEMBLY (SEE FIGURE 4) (CONT'D)											
4-29	2357	.							Screw - Hex socket flat point set	1	CD
-30	3236	.							Screw - Hex socket dog point set	1	AB
-30	3242	.							Screw - Hex socket dog point set	1	CD
									- - - - *		
-31	604790	.							Gear - Cluster, "D" Shaft	1	AB
-31	604034	.							Gear - Cluster, "D" Shaft	1	CD
-32	604804	.							Cap - Drive Shaft bearing "D" Shaft, Electrical Control	1	AB
-32	605107	.							Cap - Drive Shaft bearing "D" Shaft, Electrical Control	1	CD
-33	604805	.							Bearing - Roller	1	AB
-33	604715	.							Bearing - Roller	1	CD
-34	604714	.							Bushing	1	CD
-35	604774	.							Pump Drive - Electric Control only	1	AB
-35	604044	.							Pump Drive - Electric Control only	1	CD
-36	604791	.							Shaft - "D"	1	AB
-36	604712	.							Shaft - "D"	1	CD

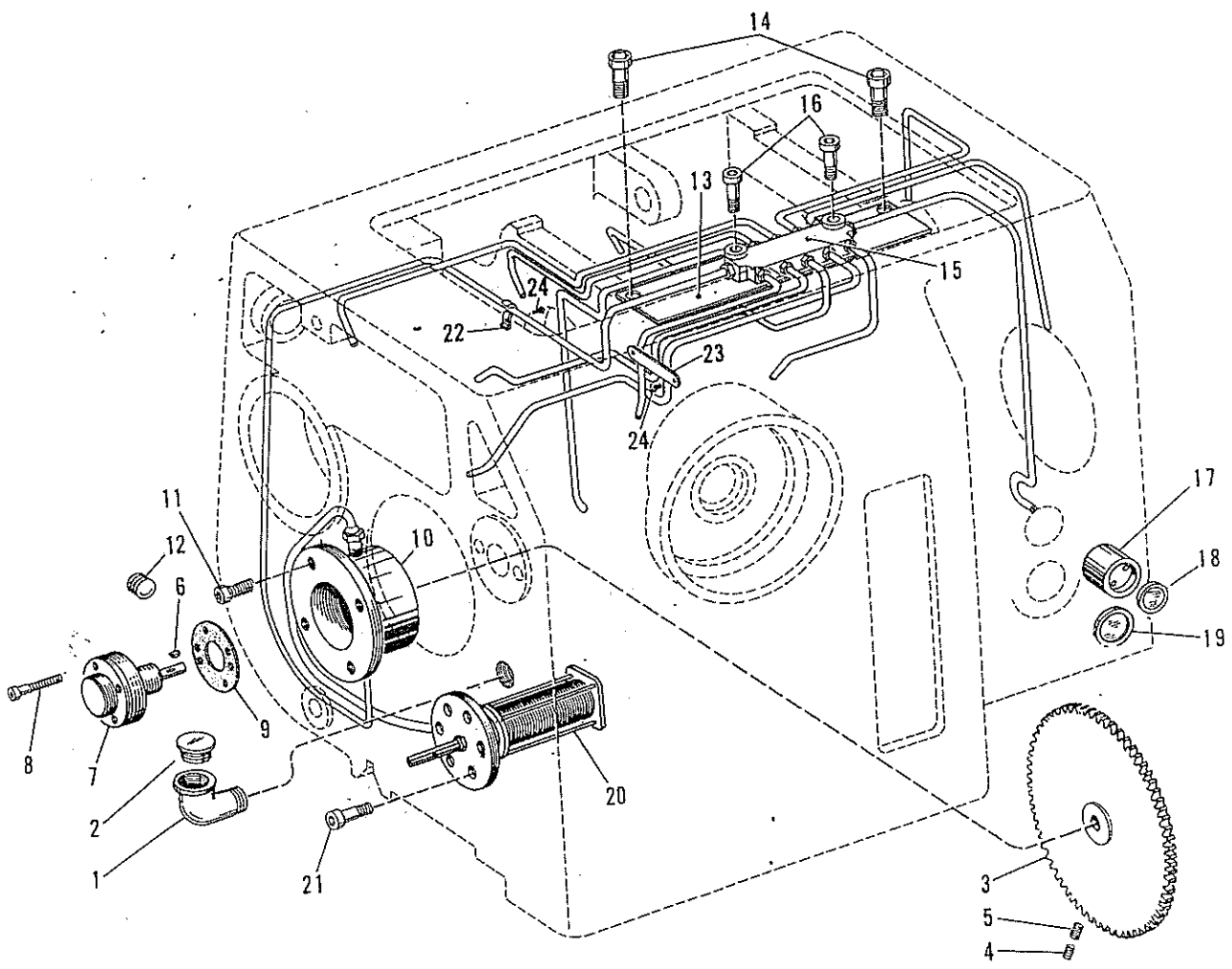

Figure 5. Headstock Lubrication System

Figure and Index No.	Part No.	1	2	3	4	5	6	7	Nomenclature	Units Per Assy	Application Code
HEADSTOCK LUBRICATION SYSTEM (SEE FIGURE 5)											
5-1	604829	.							Elbow - Street, 45°	1	AB
-1	24792	.							Elbow - Street, 90°	1	CD
-2	60959	.							Plug - Oil filler	1	All
-3	604753	.							Gear - Pump	1	AB
-3	604043	.							Gear - Pump	1	CD
Attaching Parts											
-4	2354	.							Screw - Flat point set	1	All
-5	3228	.							Screw - Hex socket dog point set	1	All
-----*											
-6	3279	.							Key	1	All
-7	604344	.							Pump	1	All
Attaching Parts											
-8	604151	.							Screw - Pump mounting	4	All
-----*											
-9	604155	.							Gasket - Pump	1	All
-10	604752	.							Housing - Pump	1	AB
-10	604091	.							Housing - Pump	1	CD
Attaching Parts											
-11	4168	.							Screw	2	AB
-11	3218	.							Screw - Socket head cap	4	CD
-----*											
-12	220784	.							Plug - Pipe	1	All
-13	604724	.							Plate - Junction, Bijur	1	AB
-13	604321	.							Plate - Junction, Bijur	1	CD
Attaching Parts											
-14	3399	.							Screw - Socket head cap	2	All
-----*											
-15	77398	.							Junction - Bijur	1	AB
-15	603304	.							Junction - Bijur	1	CD
Attaching Parts											
-16	3227	.							Screw - Socket head cap	2	All
-----*											
-17	603292	.							Bushing - Flow gage	1	All
-18	603294	.							Oil Window Unit - Open type	1	All
-19	241087	.							Gage - Oil sight	1	All
-20	603296	.							Strainer - Type KAT-F (Model 12202)	1	All
Attaching Parts											
-21	3396	.							Screw - Socket head cap	6	All
-----*											
-22	2242	.							Clamp - Oil Tube	1	All
-23	220002	.							Clip - Tubing	1	All
-24	2209	.							Screw - Drive	3	All

Figure and Index No.	Part No.	1	2	3	4	5	6	7	Nomenclature	Units Per Assy	Application Code
SPINDLE SPEED SHIFTER ASSEMBLY (SEE FIGURE 6)											
6-1	604727	.							Shifter - No. 1	1	AB
-1	604048	.							Shifter - No. 1	1	CD
Attaching Parts											
-2	140	.							Pin - Taper	1	AB
-2	143	.							Pin - Taper	1	CD
-----*											
-3	600883	.							Nut - Lock	1	AB
-3	602751	.							Nut - Lock	1	CD
-4	604723	.							Handle	3	AB

Figure and Index No.	Part No.	1	2	3	4	5	6	7	Nomenclature	Units Per Assy	Application Code
SPINDLE SPEED SHIFTER ASSEMBLY (SEE FIGURE 6) (CONT'D)											
-6-4	604414	.							Handle	3	CD
-5	605014	.							Plate, Speed, Low range	1	CD
-5	604706	.							Plate - Speed, Standard range	1	AB
-5	604053	.							Plate - Speed, Standard range	1	CD
-5	604707	.							Plate - Speed, high range	1	AB
-5	604066	.							Plate - Speed, high range	1	CD
Attaching Parts											
-6	3178	.							Screw - Drive	4	All
-----*											
-7	604735	.							Rod - Drive shaft cluster shifter (includes 604732)	1	AB
-7	604057	.							Rod - Drive shaft cluster shifter (includes 604214)	1	CD
-8	603926	.							Sleeve - Cluster back gear shifter	1	AB
-8	603924	.							Sleeve - Cluster back gear shifter	1	CD
-9	603925	.							Sleeve - Sliding back gear shifter	1	AB
-9	603923	.							Sleeve - Sliding back gear shifter	1	CD
-10	604705	.							Ring - No. 2 shifter	1	AB
-10	604054	.							Ring - No. 2 shifter	1	CD
Attaching Parts											
-11	3178	.							Screw - Drive	5	All
-----*											
-12	601429	.							Ring - "O"	1	AB
-12	246308	.							Ring - "O"	1	CD
-13	604734	.							Dial - Cluster back gear shifter	1	AB
-13	604215	.							Dial - Cluster back gear shifter	1	CD
-14	604704	.							Ring - No. 3 shifter	1	AB
-14	604056	.							Ring - No. 3 shifter	1	CD
Attaching Parts											
-15	3178	.							Screw - Drive	5	All
-----*											
-16	129367	.							Ring - "O"	1	All
-17	603927	.							Dial - Sliding back gear shifter	1	AB
-17	603922	.							Dial - Sliding back gear shifter	1	CD
-18	604703	.							Ring - Dial indicator	1	AB
-18	604055	.							Ring - Dial indicator	1	CD
Attaching Parts											
-19	3178	.							Screw - Drive	8	All
-----*											
-20	247548	.							Ring - "O"	1	AB
-20	244791	.							Ring - "O"	1	CD
-21	604730	.							Bar - Detent shifter	1	AB
-21	604051	.							Bar - Detent shifter	1	CD
-22	604731	.							Support - Shifter bar	1	AB
-22	604052	.							Support - Shifter bar	1	CD
Attaching Parts											
-23	603969	.							Pin - Taper	4	All
-24	2300	.							Screw - Socket head cap	4	AB
-24	3402	.							Screw - Socket head cap	4	CD
-----*											
-25	2355	.							Screw - Hollow hex lock	3	All
-26	605050	.							Spring - Detent shifter	3	All
-27	30060	.							Ball - 1/4" Diameter	3	All
-28	227592	.							Pin	3	AB
-28	3636	.							Pin	3	CD
-29	240097	.							Pin - Shifter bar	3	AB
-29	1384	.							Pin - Shifter bar	3	CD
-30	603955	.							Pin - Roll	6	All
-31	604737	.							Bar - No. 1 shifter	1	AB
-31	604061	.							Bar - No. 1 shifter	1	CD
-32	604738	.							Bar - No. 2 shifter	1	AB
-32	604060	.							Bar - No. 2 shifter	1	CD
-33	604739	.							Bar - No. 3 shifter	1	AB
-33	604059	.							Bar - No. 3 shifter	1	AB
-34	604740	.							Shifter - No. 1 drive shaft cluster	1	AB
-34	604062	.							Shifter - No. 1 drive shaft cluster	1	CD

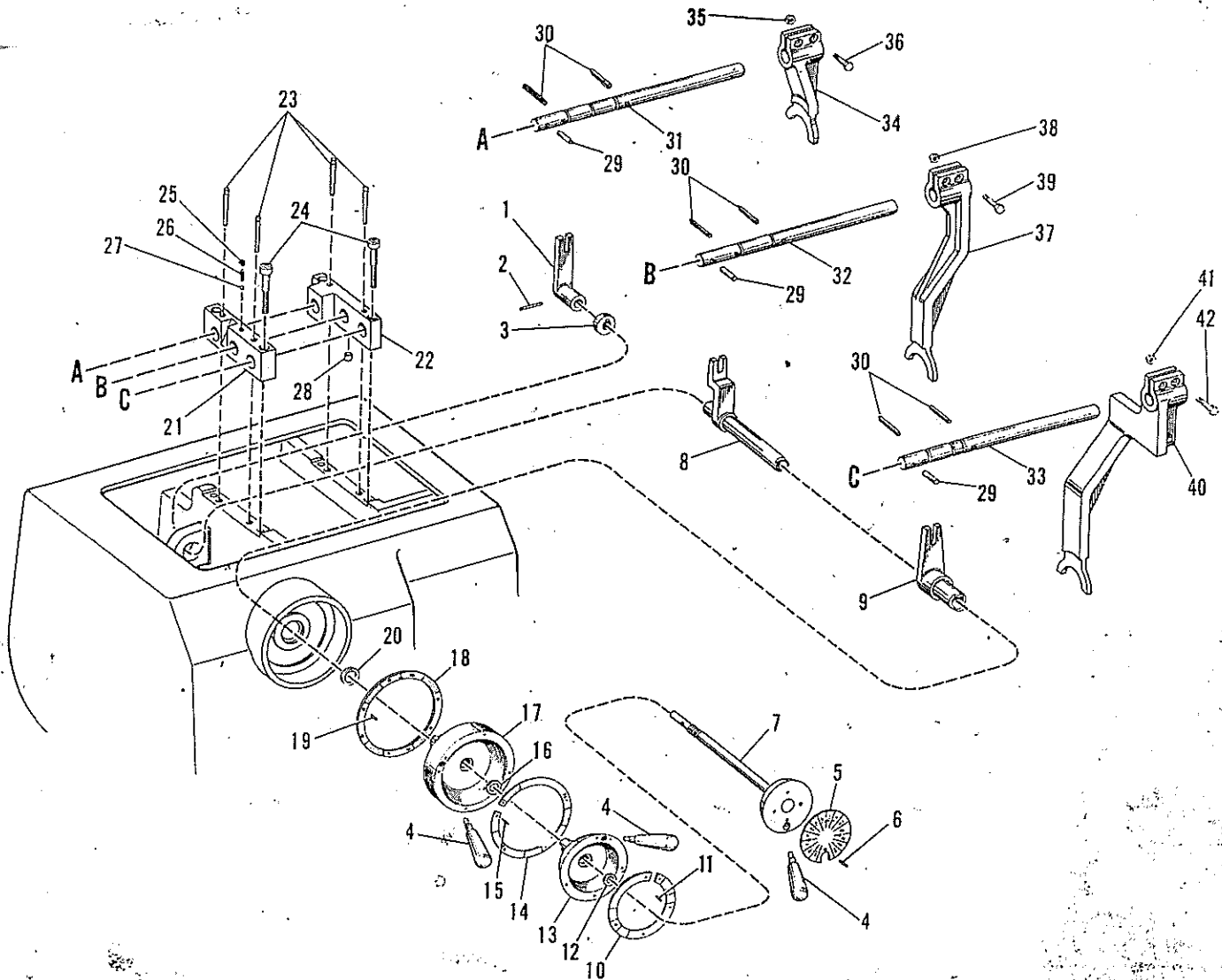

Figure 6. Spindle Speed Shifter Assembly

Figure and Index No.	Part No.	1	2	3	4	5	6	7	Nomenclature	Units Per Assy	Application Code
SPINDLE SPEED SHIFTER ASSEMBLY (SEE FIGURE 6) (CONT'D)											
Attaching Parts											
6-35	702723								. Nut - Hex, thin, lock *	2	All
-36	607415								. Screw - Hex head cap	2	All
-----*											
-37	604741								. Shifter - No. 2, back gear cluster	1	AB
-37	604971								. Shifter - No. 2, back gear cluster	1	CD
Attaching Parts											
-38	702723								. Nut - Hex, thin, lock	2	All
-39	607415								. Screw - Hex head cap	2	All
-----*											
-40	604742								. Shifter - No. 3, back gear increment	1	AB
-40	604972								. Shifter - No. 3, back gear increment	1	CD
Attaching Parts											
-41	702723								. Nut - Hex, thin, lock	2	All
-42	607415								. Screw - Hex head cap	2	All

Figure and Index No.	Part No.	Nomenclature							Units Per Assy	Application Code
MECHANICAL AND ELECTRICAL CONTROLS ASSEMBLIES (SEE FIGURE 7)										
7-1	Delete									
-2	Delete									
-3	3806	. Nut - Positive lock							1	All
-4	604757	. Shifter - Clutch							1	AB
-4	604045	. Shifter - Clutch							1	CD
-5	1959	. Pin - Cotter							2	All
-6	604794	. Shoe - Clutch shifter							2	AB
-6	608272	. Shoe - Clutch shifter							2	CD
-7	3808	. Nut - Positive lock							1	All
-8	604736	. Shaft - Clutch shifter							1	AB
-8	603324	. Shaft - Clutch shifter							1	CD
-9	604114	. Gear - Clutch shaft operating							2	All
		Attaching Parts								
-10	2354	. Screw - Socket head lock							2	All
-11	3228	. Screw - Socket dog point							2	All
		- - - - - * - - - - -								
-12	3234	. Screw - Socket head lock							1	All
-13	2356	. Screw - Socket dog point							1	All
-14	604430	. Bush - Front							1	All
-15	604722	. Shaft - Pinion							1	AB
-15	604113	. Shaft - Pinion							1	CD
-16	603903	. Bearing - Plain							1	All
-17	604721	. Guide - Control rod							1	AB
-17	603556	. Guide - Control rod							1	CD
		Attaching Parts								
-18	3266	. Screw - Socket head cap							2	All
		- - - - - * - - - - -								
-19	3377	. Pin - Straight							1	All
-20	603291	. Link - Cam lock clutch							1	All
		Attaching Parts								
-21	603325	. Pin - Filter							2	All
-22	3329	. Pin - Cotter							3	All
		- - - - - * - - - - -								
-23	603295	. Clutch - Cam lock							1	All
-24	2336	. Screw - Hex socket							2	All
-25	3945	. Spring - Compression							2	All
-26	601022	. Plunger							2	All
-27	604875	. Housing - Plunger							1	All
-28	605292	. Rod - Connecting							1	A
-28	604719	. Rod - Connecting							1	B
-28	604323	. Rod - Connecting							1	C
-28	604324	. Rod - Connecting							1	D
-29	3299	. Pin - Straight							1	AB
-29	1384	. Pin - Straight							1	CD
-30	601019	. Lever - Control rod							1	AB
-30	602296	. Lever - Control rod							1	CD
		Attaching Parts								
-31	663	. Pin - Taper							1	All
		- - - - - * - - - - -								
-32	604417	. Gear - Switch operating							1	All
		Attaching Parts								
-33	2354	. Screw - Socket head lock							1	All
-34	3229	. Screw - Socket dog point							1	All
		- - - - - * - - - - -								
-35	2356	. Screw - Socket head lock							1	All
-36	2346	. Screw - Socket dog point							1	All
-37	604418	. Ring - Retaining internal snap							1	All
-38	604296	. Stud - Electric Control							1	All
-39	604297	. Bushing - Electric control							1	All
-40	604196	. Switch - Cam operated drum							1	All
-41	3553	. Plug - Electric control							1	All

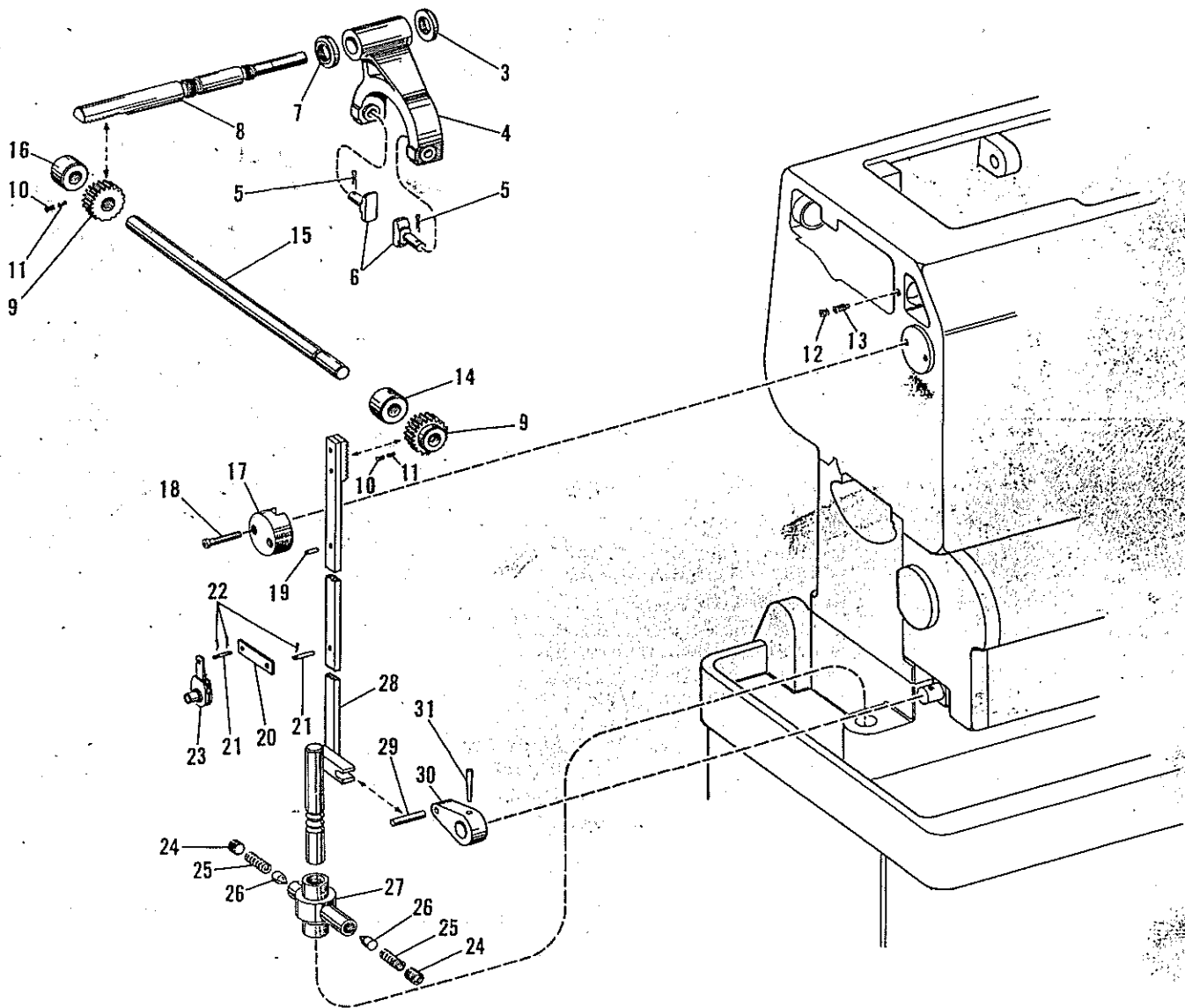
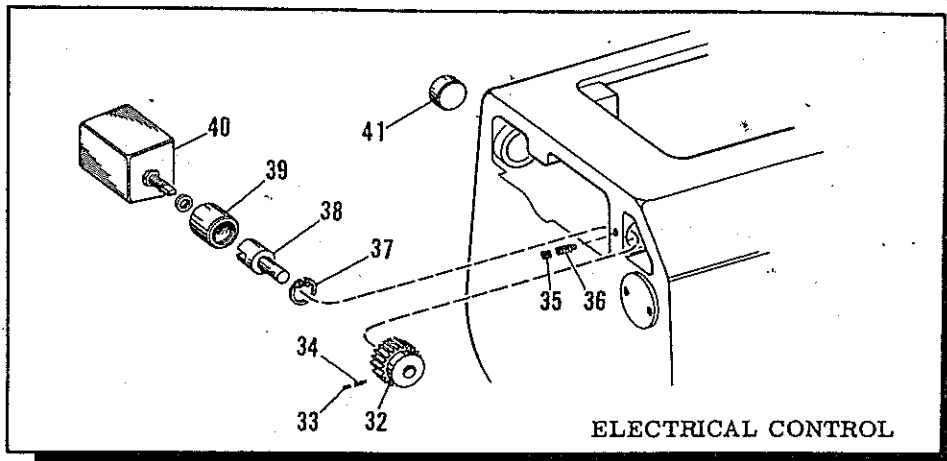

Figure 7. Mechanical and Electrical Controls Assemblies

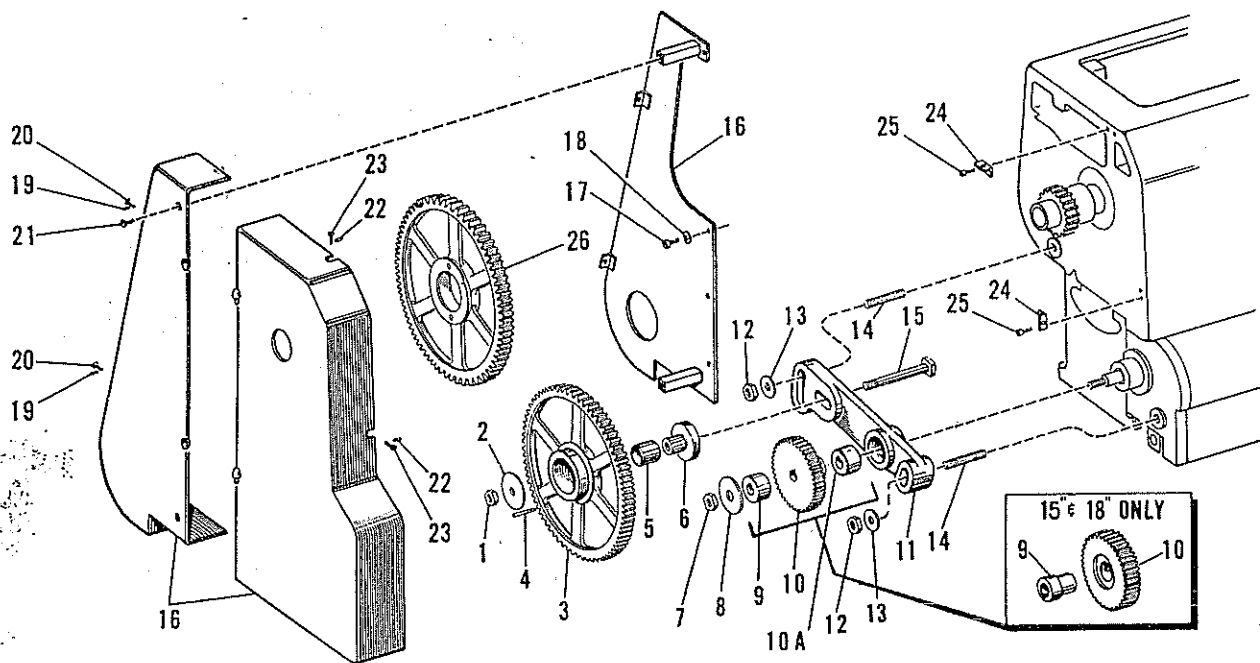

Figure 8. End Gearing Assembly

Figure and Index No.	Part No.	Nomenclature	Units Per Assy	Application Code
		1 2 3 4 5 6 7		
END GEARING ASSEMBLY (SEE FIGURE 8)				
8-1	607390	. Nut - Hex full	1	All
-2	600695	. Washer - Plain	1	AB
-2	607386	. Washer - Plain	1	CD
-3	607366	. Gear - Quadrant 120T	1	AB
-3	607398	. Gear - Quadrant 120T	1	CD
-4	3304	. Pin - Taper	1	AB
-4	663	. Pin - Taper	1	CD
-5	600693	. Bearing - Plain	1	AB
-5	607387	. Bearing - Plain	1	CD
-6	607401	. Bushing - Quadrant gear	1	AB
-6	607385	. Bushing - Quadrant gear	1	CD
-7	3478	. Nut - Hex full	1	AB
-7	3479	. Nut - Hex full	1	CD
-8	600695	. Washer - Plain	1	AB
-8	607386	. Washer - Plain	1	CD
-9	601041	. Spacer - Change gear	1	AB
-9	607389	. Spacer - Change gear	1	CD
-10	607369	. Gear - Drive shaft 54T (American)	1	AB
-10	607370	. Gear - Drive shaft 72T (Metric)	1	AB
-10	607392	. Gear - Drive shaft 48T (American)	1	CD
-10	607393	. Gear - Drive shaft 64T (Metric)	1	CD
-10A	607365	. Spacer - Change gear	1	AB
-11	604673	. Plate - Quadrant	1	AB
-11	604383	. Plate - Quadrant	1	CD
Attaching Parts				
-12	3473	. Nut - Thin hex	2	AB
-12	76639	. Nut - Thin hex	2	CD
-13	3441	. Washer - Plain	2	AB
-14	600198	. Stud	2	AB
-14	604143	. Stud	2	CD
-----*				
-15	600619	. Bolt - Tee	1	AB
-15	603502	. Bolt - Tee	1	CD

Figure and Index No.	Part No.	Nomenclature							Units Per Assy	Application Code
END GEARING ASSEMBLY (SEE FIGURE 8) (CONT'D)										
8-16	604685	.							1	A
-16	604686	.							1	B
-16	604427	.							1	C
-16	604428	.							1	D
Attaching Parts										
-17	3210	.							4	All
-18	1934	.							4	All
-19	600478	.							2	All
-20	600477	.							2	All
-21	3422	.							2	ABD
-21	206279	.							2	C
-22	3539	.							2	All
-23	603344	.							2	All
----- *										
-24	603327	.							2	All
-25	3204	.							4	All
-26	607367	.							1	AB
-26	607399	.							1	CD

Figure and Index No.	Part No.	Nomenclature							Units Per Assy	Application Code
LEADSCREW AND CONTROL ROD ASSEMBLIES (SEE FIGURE 9)										
9-1	604642	.							1	AB
-1	604126	.							1	CD
Attaching Parts										
-2	3285	.							2	AB
-2	3543	.							2	CD
-3	3161	.							4	AB
-3	3192	.							4	CD
----- *										
-4	60062	.							1	All
-5	69583	.							1	All
-6	203828	.							1	All
-7	601083	.							1	AB
-7	601058	.							1	CD
-8	216283	.							2	AB
-8	94705	.							2	CD
-9	600733	.							1	AB
-9	600027	.							2	CD
-10	601082	.							1	AB
-10	601057	.							1	CD
-11	604645	.							1	AB
-11	604124	.							1	CD
-11	604450	.							1	CD
Attaching Parts										
-12	642	.							1	All
----- *										
-13	3922	.							1	All
-14	1040	.							1	AB
-14	601056	.							1	CD
-15	604644	.							1	AB
-15	604125	.							1	CD
Attaching Parts										
-16	642	.							1	AB
-16	645	.							1	CD
----- *										
-17	4190	.							1	AB
-17	4191	.							1	CD

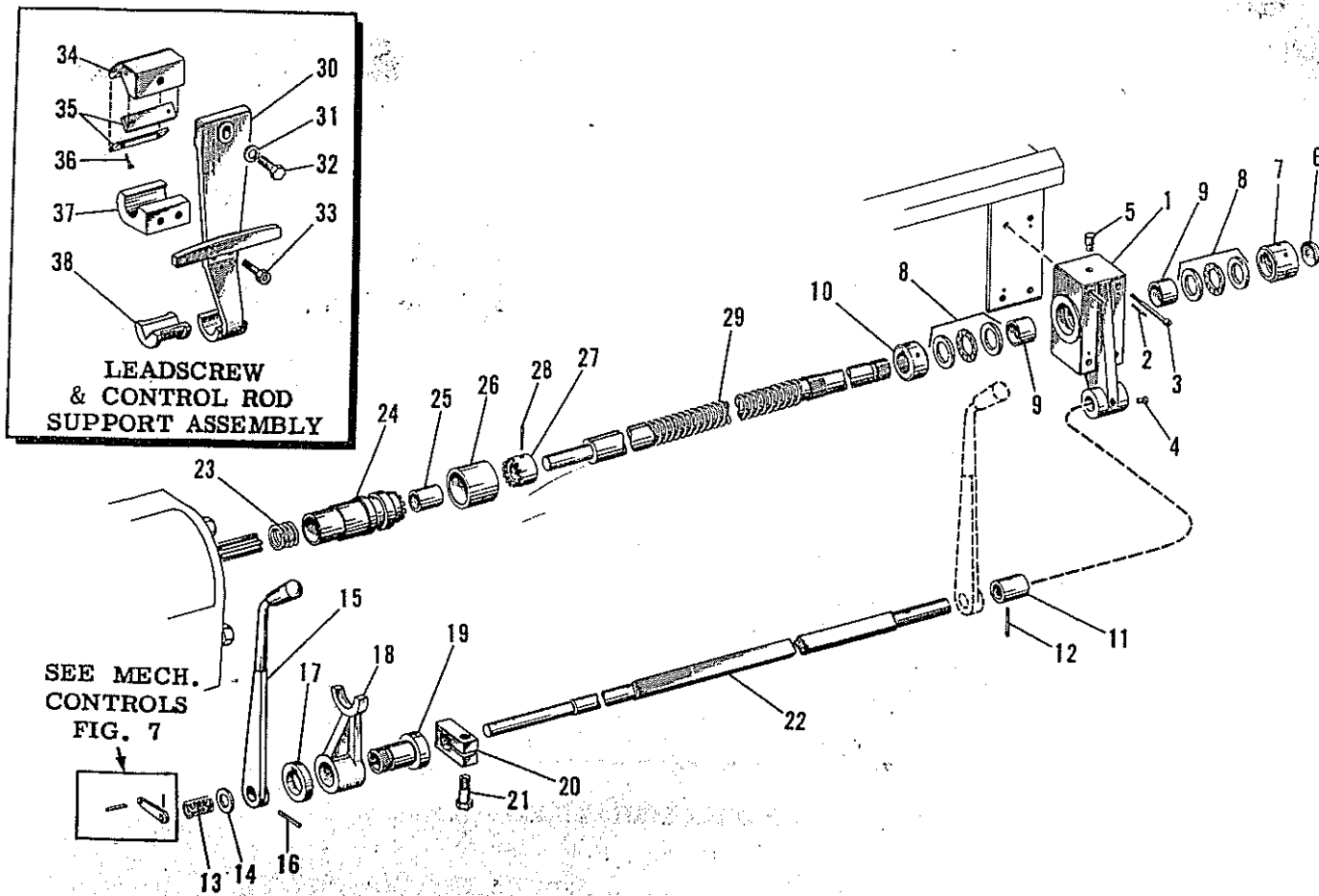

Figure 9. Leadscrew and Control Rod Assemblies

Figure and Index No	Part No.	Nomenclature	Units Per Assy	Application Code
		1 2 3 4 5 6 7		
LEADSCREW AND CONTROL ROD ASSEMBLIES (SEE FIGURE 9) (CONT'D)				
9-18	601349	. Lever - Trip	1	AB
-18	601347	. Lever - Trip	1	CD
-19	601350	. Bushing - Trip lever	1	AB
-19	601348	. Bushing - Trip lever	1	CD
-20	601084	. Stop - Length	1	AB
-20	604235	. Stop - Length	1	CD
		Attaching Parts		
-21	2260	. Screw - Hex head	1	AB
-21	3428	. Screw - Hex head	1	CD
-22	604641	. Rod - Operating	1	AB
-22	604129	. Rod - Operating	1	CD
-23	601216	. Spring - Trip	1	AB
-23	226199	. Spring - Trip	1	CD
-24	604643	. Housing - Clutch	1	AB
-24	604128	. Housing - Clutch	1	CD
-25	604648	. Bearing - Plain, clutch	1	AB
-25	604123	. Bearing - Plain, clutch	1	CD
-26	604647	. Collar - L-00	1	A
-26	604818	. Collar - D1-3	1	A
-26	604818	. Collar - D1-4	1	AB
-26	604646	. Collar - L-0	1	AB
-26	604132	. Collar - L-1 (Regular)	1	CD
-26	604132	. Collar - D1-6 (Regular)	1	D
-26	604436	. Collar - L-0 and D1-4 (Regular)	1	C
-26	604451	. Collar - D1-6 only (Regular and Gap)	1	C

Figure and Index No.	Part No.	1	2	3	4	5	6	7	Nomenclature	Units Per Assy	Application Code
LEADSCREW AND CONTROL ROD ASSEMBLIES (SEE FIGURE 9) (CONT'D)											
9-26	604134								. Collar - L-0 and L-1 (Gap) D1-4 and D1-6 (Gap)	1	CD
-27	601415								. Clutch - Leadscrew	1	AB
-27	601532								. Clutch - Leadscrew	1	CD
Attaching Parts											
-28	143								. Pin - Taper	1	AB
-28	105165								. Pin - Taper	1	CD
----- *											
-29	604637								. Leadscrew - American	1	AB
-29	604638								. Leadscrew - Metric	1	AB
-29	604130								. Leadscrew - American	1	CD
-29	604131								. Leadscrew - Metric	1	CD
-30	604136								. Support	AR	CD
Attaching Parts											
-31	888								. Washer	1	CD
-32	3428								. Screw - Hex head	1	CD
-33	3396								. Screw - Socket head cap	2	CD
----- *											
-34	604237								. Block - Vee way	AR	CD
-35	601983								. Strip - Vee way	AR	CD
Attaching Parts											
-36	3198								. Screw - Low socket head cap	4	CD
----- *											
-37	601985								. Block - Leadscrew support	AR	CD
-38	601986								. Support - Control rod	AR	CD

Figure and Index No.	Part No.	1	2	3	4	5	6	7	Nomenclature	Units Per Assy.	Application Code
QUICK CHANGE GEAR BOX (FRONT VIEW) (SEE FIGURE 10)											
10-1	604466								. Cover - End	1	AB
-1	603514								. Cover - End	1	CD
Attaching Parts											
-2	124975								. Screw - Socket head cap	4	AB
-2	2320								. Screw - Socket head cap	4	CD
----- *											
-3	601558								. Bearing - Needle	2	AB
-3	603478								. Bearing - Needle	2	CD
-4	604516								. Bush - Pivot end cover, "D" Shaft	1	AB
-4	603473								. Bush - Pivot end cover, "D" Shaft	1	CD
-5	604517								. Bearing - Plain, "D" Shaft	1	AB
-5	603474								. Bearing - Plain, "D" Shaft	1	CD
-6	604470								. Gear - Large	1	AB
-6	603471								. Gear - Large	1	CD
-7	108016								. Key - Gear and drive shaft	1	All
-8	3280								. Key - Hi-pro	1	All
-9	604519								. Shaft - Drive	1	AB
-9	603472								. Shaft - Drive	1	CD
-10	604495								. Handle - Shifter	1	AB
-10	604224								. Handle - Shifter	1	CD
-11	605104								. Shifter - Left hand	1	AB
-11	605240								. Shifter - Left hand	1	CD
Attaching Parts											
-12	3217								. Screw - Socket head cap	1	AB
-12	3251								. Screw - Socket head cap	1	CD
----- *											
-13	3942								. Spring - Compression	1	All
-14	30154								. Ball - Steel	1	All
-15	605103								. Bushing - Handle shifter, left hand	1	AB
-15	604998								. Bushing - Handle shifter, left hand	1	CD

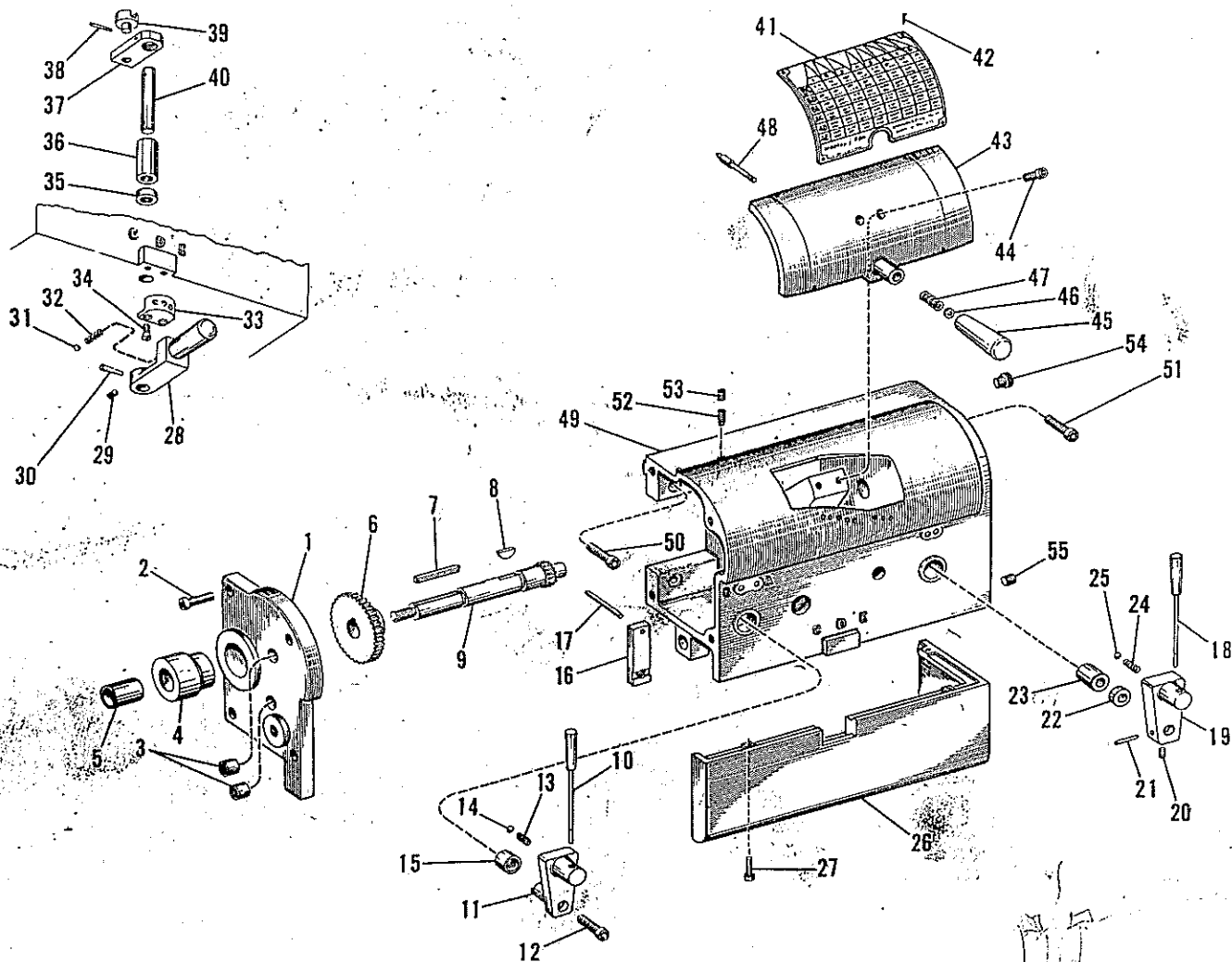

Figure 10. Quick Change Gear Box (Front View)

Figure and Index No.	Part No.	Nomenclature	Units Per Assy	Application Code
		1 2 3 4 5 6 7		
QUICK CHANGE GEAR BOX (FRONT VIEW) (SEE FIGURE 10) (CONT'D)				
10-16	604997	. Shifter - Drive gear	1	AB
-16	605100	. Shifter - Drive gear	1	CD
-17	605102	. Pin - Shifter, drive gear	1	AB
-17	601177	. Pin - Shifter, drive gear	1	CD
-18	604495	. Handle - Shifter	1	AB
-18	604224	. Handle - Shifter	1	CD
-19	604494	. Shifter - Right hand	1	AB
-19	603513	. Shifter - Right hand	1	CD
Attaching Parts				
-20	2332	. Screw - Hex socket set	1	AB
-20	1911	. Screw - Hex socket set	1	CD
-21	141	. Pin - Taper	1	AB
-21	143	. Pin - Taper	1	CD
-----*				
-22	600402	. Seal - Oil	1	All
-23	604491	. Bushing - Handle shifter, right hand	1	AB
-23	603537	. Bushing - Handle shifter, right hand	1	CD
-24	3942	. Spring - Compression	1	All
-25	30154	. Ball - Steel	1	All
-26	604456	. Skirt - Quick change box	1	AB

Figure and Index No	Part No.	Nomenclature						Units Per Assy	Application Code		
		1	2	3	4	5	6	7			
QUICK CHANGE GEAR BOX (FRONT VIEW) (SEE FIGURE 10) (CONT'D)											
10-26	603485	.							Skirt - Quick change box	1	CD
		Attaching Parts									
-27	3227	.							Screw - Socket head cap	3	All
		----- *									
-28	604480	.							Handle - Shifter	1	AB
-28	603508	.							Handle - Shifter	1	CD
		Attaching Parts									
-29	2332	.							Screw - Flat point hex socket set	1	AB
-29	1911	.							Screw - Flat point hex socket set	1	CD
-30	232350	.							Pin - Taper	1	CD
		----- *									
-31	30154	.							Ball - Steel	1	All
-32	3942	.							Spring - Compression	1	All
-33	604486	.							Selector - Back shaft gear	1	AB
-33	603503	.							Selector - Back shaft gear	1	CD
		Attaching Parts									
-34	3462	.							Screw - Flat head machine	2	All
		----- *									
-35	600402	.							Seal - Oil	1	All
-36	604488	.							Bushing - Handle shifter	1	AB
-36	603505	.							Bushing - Handle shifter	1	CD
-37	604490	.							Lever - Shifter	1	AB
-37	603507	.							Lever - Shifter	1	CD
		Attaching Parts									
-38	140	.							Pin - Taper	1	All
		----- *									
-39	604489	.							Shoe - Sliding clutch shifter	1	AB
-39	603504	.							Shoe - Sliding clutch shifter	1	CD
-40	603506	.							Shaft - Shifter	1	All
-41	604521	.							Plate - Index, American (English)	1	AB
-41	604522	.							Plate - Index, Metric (English)	1	AB
-41	603498	.							Plate - Index, American (English)	1	CD
-41	603497	.							Plate - Index, Metric (English)	1	CD
		Attaching Parts									
-42	2209	.							Screw - Drive	4	All
		----- *									
-43	604464	.							Slide - Index	1	AB
-43	603600	.							Slide - Index	1	CD
		Attaching Parts									
-44	603980	.							Screw - Index slide	2	AB
-44	603981	.							Screw - Index slide	2	CD
		----- *									
-45	604481	.							Handle	1	AB
-45	604158	.							Handle	1	CD
-46	600095	.							Bushing - Shifter handle	1	All
-47	203247	.							Spring - Compression	1	All
-48	604479	.							Plunger	1	AB
-48	604157	.							Plunger	1	CD
-49	605105	.							Box - Quick Change	1	AB
-49	603515	.							Box - Quick Change	1	CD
		Attaching Parts									
-50	3209	.							Screw - Low socket head cap	1	AB
-50	3400	.							Screw - Socket head cap	2	CD
-51	3266	.							Screw - Socket head cap	3	AB
-51	3266	.							Screw - Socket head cap	2	CD
		----- *									
-52	2330	.							Screw - Hex socket set	1	AB
-53	2353	.							Screw - Low socket set	1	AB
-54	90377	.							Plug - Oil filler	1	All
-55	76645	.							Plug - Pipe	1	AB
-55	220784	.							Plug - Pipe	1	CD

Figure and Index No.	Part No.	Nomenclature	Units Per Assy	Application Code
		1 2 3 4 5 6 7		
QUICK CHANGE GEAR BOX (REAR VIEW) (SEE FIGURE 11)				
11-1	604476	. Retainer - "A" and "C" Shaft	1	AB
-1	603489	. Retainer - "A" and "C" Shaft	1	CD
-2	600082	. Bearing - Plain, "C" Shaft	1	AB
-2	603486	. Bearing - Plain, "C" Shaft	1	CD
-3	3279	. Key - Woodruff	1	AB
-3	3280	. Key - Hi-pro	1	CD
-4	604461	. Shaft - Tumbler gear, "C" Shaft	1	AB
-4	603496	. Shaft - Tumbler gear, "C" Shaft	1	CD
-5	604468	. Gear - Feed reverse 9", "C" Shaft	1	AB
-5	603488	. Gear - Feed reverse, "C" Shaft	1	CD
-6	604469	. Bearing - Plain, "C" Shaft	1	AB
-6	603480	. Bearing - Plain, "C" Shaft	1	CD
-7	601576	. Spacer - Tumbler gear shaft	1	AB
-7	601535	. Spacer - Tumbler gear shaft	1	CD
-8	601564	. Bearing - Needle	1	AB
-8	601525	. Bearing - Needle	1	CD
-9	601110	. Bushing	1	CD
-10	604523	. Bearing - Plain	2	AB
-10	600384	. Bearing - Plain	2	CD
-11	601575	. Gear - Tumbler	1	AB
-11	601498	. Gear - Tumbler	1	CD
-12	601429	. Ring - "O"	1	AB
-12	601543	. Ring - "O"	1	CD
-13	601571	. Race - Inner, "C" Shaft	1	AB
-13	603475	. Race - Inner, "C" Shaft	1	CD
-14	601066	. Bearing - Needle	1	AB
-14	603476	. Bearing - Needle	1	CD
-15	604518	. Gear - Cluster	1	AB
-15	603470	. Gear - Cluster	1	CD
-16	604498	. Shaft - Tumbler idler gear	1	AB
-16	604415	. Shaft - Tumbler idler gear	1	CD
-17	703	. Pin - Cotter	1	All
-18	604482	. Gear - Tumbler idler	1	AB
-18	603449	. Gear - Tumbler idler	1	CD
-19	604557	. Bearing - Plain	1	AB
-19	604524	. Bearing - Plain	1	CD
-20	2330	. Screw - Hex socket set	2	AB
-20	2332	. Screw - Hex socket flat set	1	CD
-21	2339	. Screw - Socket head set	2	AB
-21	3228	. Screw - Hex socket dog point	1	CD
-22	604465	. Yoke - Tumbler	1	AB
-22	603596	. Yoke - Tumbler	1	CD
-23	3336	. Letter - Raised identification	1	All
-24	604477	. Retainer - Drive clutch	1	AB
-24	603490	. Retainer - Drive clutch	1	CD
-25	600058	. Bearing - Plain	1	AB
-25	600354	. Bearing - Plain	1	CD
-26	604520	. Clutch - Drive	1	AB
-26	601102	. Clutch - Drive	1	CD
-27	3279	. Key - Woodruff	1	AB
-27	3280	. Key - Hi-pro	1	CD
-28	604457	. Shaft - "A"	1	AB
-28	603595	. Shaft - "A"	1	CD
-29	601563	. Bearing - Plain	2	AB
-29	601526	. Bearing - Plain	2	CD
-30	604460	. Gear - Cluster, "A" Shaft	1	AB
-30	603493	. Gear - Cluster, "A" Shaft	1	CD
-31	601564	. Bearing - Needle	1	AB
-31	601525	. Bearing - Needle	1	CD
-32	600049	. Collar	1	AB
-32	600348	. Collar	1	CD

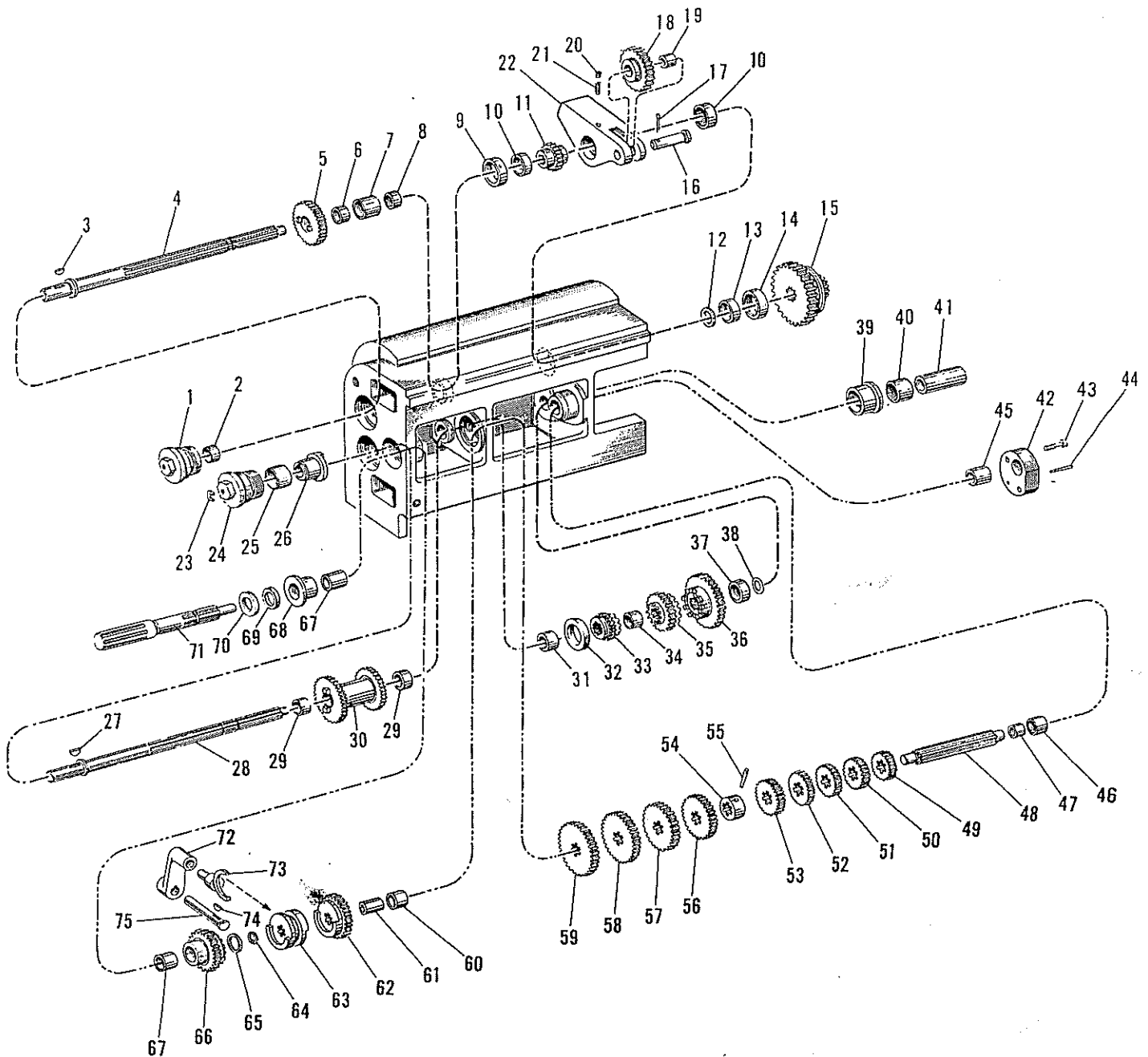

Figure 11. Quick Change Gear Box (Rear View)

Figure and Index No.	Part No.	1	2	3	4	5	6	7	Nomenclature	Units Per Assy	Application Code
QUICK CHANGE GEAR BOX (REAR VIEW) (SEE FIGURE 11) (CONT'D)											
11-33	604473	.							Gear - Clutch	1	AB
-33	603451	.							Gear - Clutch	1	CD
-34	601563	.							Bearing - Plain	1	AB
-34	603483	.							Bearing - Plain	1	CD
-35	604462	.							Gear - Sliding clutch, "A" Shaft	1	AB
-35	603450	.							Gear - Sliding clutch, "A" Shaft	1	CD
-36	604463	.							Gear - Clutch, "A" Shaft	1	AB
-36	603448	.							Gear - Clutch, "A" Shaft	1	CD
-37	601561	.							Bearing - Plain	1	AB

Figure and Index No.	Part No.	Nomenclature							Units Per Assy	Application Code
		1	2	3	4	5	6	7		
QUICK CHANGE GEAR BOX (REAR VIEW) (SEE FIGURE 11) (CONT'D)										
11-37	601521	.							1	CD
-38	243716	.							1	AB
-38	246308	.							1	CD
-39	604472	.							1	AB
-39	603594	.							1	CD
-40	601560	.							1	AB
-40	601520	.							1	CD
-41	601559	.							1	AB
-41	603477	.							1	CD
-42	604478	.							1	AB
-42	601125	.							1	CD
		Attaching Parts							2	AB
-43	3218	.							2	CD
-43	3396	.							1	AB
-44	140	.							1	CD
-44	3304	.							1	CD
		----- *							1	AB
-45	600342	.							1	CD
-45	600347	.							1	AB
-46	604504	.							1	CD
-46	603479	.							1	AB
-47	604505	.							1	AB
-48	604459	.							1	CD
-48	603494	.							1	AB
-49	604501	.							1	CD
-49	603452	.							1	AB
-50	604511	.							1	CD
-50	603453	.							1	AB
-51	604510	.							1	CD
-51	603454	.							1	AB
-52	604509	.							1	CD
-52	603455	.							1	AB
-53	604502	.							1	CD
-53	603456	.							1	AB
-54	604503	.							1	CD
-54	603461	.							1	CD
		Attaching Parts							1	AB
-55	2291	.							1	CD
-55	143	.							1	CD
		----- *							1	AB
-56	604508	.							1	CD
-56	603457	.							1	AB
-57	604507	.							1	CD
-57	603458	.							1	AB
-58	604506	.							1	CD
-58	603459	.							1	AB
-59	604500	.							1	CD
-59	603460	.							1	AB
-60	600059	.							1	CD
-60	603481	.							1	AB
-61	600082	.							1	CD
-61	603482	.							1	AB
-62	604499	.							1	CD
-62	603492	.							1	AB
-63	601565	.							1	CD
-63	601528	.							1	AB
-64	240852	.							1	CD
-64	237432	.							1	AB
-65	600077	.							1	CD
-65	600374	.							1	AB
-66	604467	.							1	CD
-66	603491	.							1	CD

Figure and Index No.	Part No.	1	2	3	4	5	6	7	Nomenclature	Units Per Assy	Application Code
QUICK CHANGE GEAR BOX (REAR VIEW) (SEE FIGURE 11) (CONT'D)											
11-67	601566	.							Bearing - Plain	1	AB
-67	603484	.							Bearing - Plain	2	CD
-68	601260	.							Bushing - Feed reverse shaft	1	AB
-68	603487	.							Bushing - Feed reverse shaft	1	CD
-69	600074	.							Bearing - Thrust	1	AB
-69	600371	.							Bearing - Thrust	1	CD
-70	700019	.							Washer - Thrust	1	AB
-70	601115	.							Washer - Thrust	1	CD
-71	604458	.							Shaft - Feed reverse	1	AB
-71	603495	.							Shaft - Feed reverse	1	CD
-72	604492	.							Shifter - Feed reverse clutch	1	AB
-72	603499	.							Shifter - Feed reverse clutch	1	CD
-73	600152	.							Shoe - Shifter	1	AB
-73	600413	.							Shoe - Shifter	1	CD
-74	3279	.							Key - Hi-pro	1	All
-75	604487	.							Shaft - Shifter	1	AB
-75	603500	.							Shaft - Shifter	1	CD

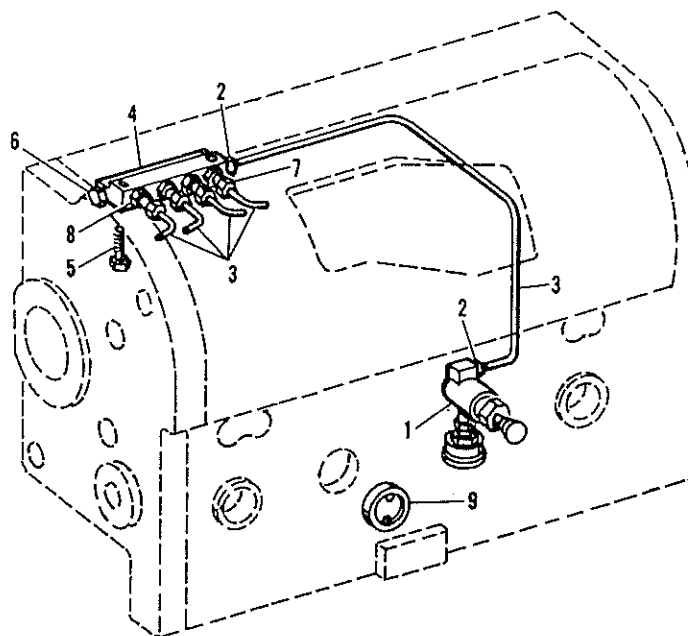

Figure 12. Quick Change Gear Box Lubrication System

Figure and Index No.	Part No.	1	2	3	4	5	6	7	Nomenclature	Units Per Assy	Application Code
QUICK CHANGE GEAR BOX LUBRICATION SYSTEM (SEE FIGURE 12)											
12-1	603893	.							Lubricator	1	All
-2	600181	.							Bushing - Compression	1	AB
-2	600181	.							Bushing - Compression	2	CD
-2	600182	.							Sleeve - Compression	1	AB
-2	600182	.							Sleeve - Compression	2	CD
-3	604496	.							Tubing - Oil	AR	AB
-3	603598	.							Tubing - Oil	AR	CD
-4	604497	.							Distributor - Lubrication	1	AB
-4	603512	.							Junction - 6 way single	1	CD

Figure and Index No.	Part No.	1	2	3	4	5	6	7	Nomenclature	Units Per Assy	Application Code
QUICK CHANGE GEAR BOX LUBRICATION SYSTEM (SEE FIGURE 12) (CONT'D)											
Attaching Parts											
12-5	3246	.							Screw - Socket head cap	2	CD
									* - - - - -		
-6	1550	.							Plug - Brass	1	AB
-6	603597	.							Plug - Closure	1	CD
-7	600188	.							Nut - Compression	4	CD
-7	600189	.							Sleeve - Compression	4	CD
-8	600191	.							Unit - Metering (FJD-D)	4	CD
-9	237701	.							Gage - Oil sight	1	All

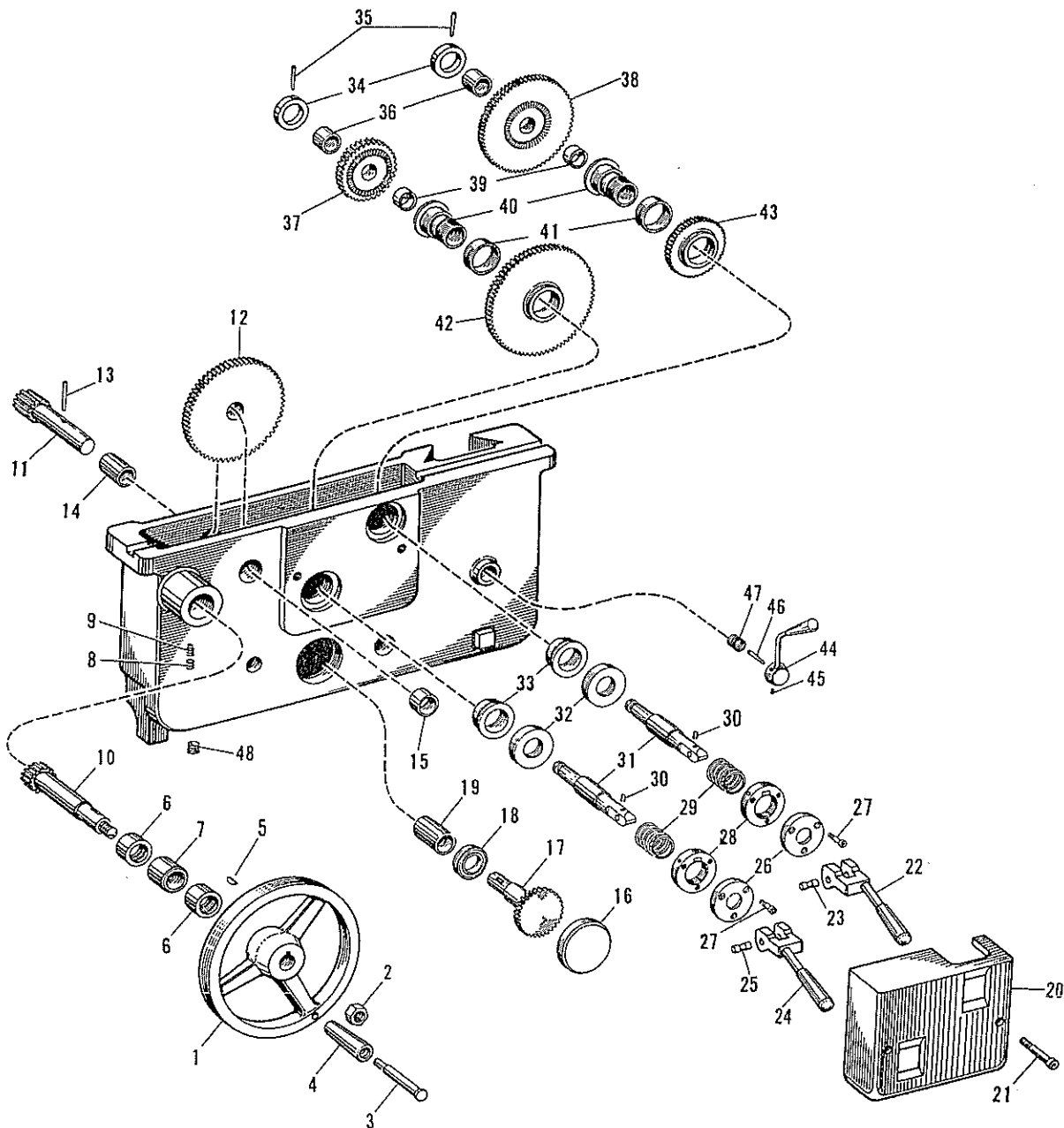

Figure 13. Apron - 10" and 12-1/2" (Front View)

APRON - 10" and 12-1/2" (FRONT VIEW) (SEE FIGURE 13)

13-1	603390	. Handwheel	1	AB
		Attaching Parts		
-2	3479	. Nut - Jam	1	AB
		----- *		
-3	604167	. Stud - Handle	1	AB
-4	604165	. Handle - Handwheel	1	AB
-5	3280	. Key - Hi-pro	1	AB
-6	237109	. Bearing - Needle	2	AB
-7	604617	. Collar - Handwheel	1	AB
		Attaching Parts		
-8	2356	. Screw - Hollow hex lock	1	AB
-9	2345	. Screw - Set	1	AB
		----- *		
-10	604616	. Pinion - Handwheel	1	AB
-11	604593	. Pinion - Rack	1	AB
-12	604594	. Gear - Rack pinion	1	AB
		Attaching Parts		
-13	642	. Pin - Taper	1	AB
		----- *		
-14	604615	. Bearing - Plain oilite	1	AB
-15	241507	. Bushing - Oilite	1	AB
-16	604542	. Plug	1	AB
-17	604603	. Gear - Main drive	1	AB
-18	93234	. Seal - Oil	1	AB
-19	604601	. Bearing - Plain oilite	1	AB
-20	604587	. Housing - Drop lever	1	AB
		Attaching Parts		
-21	3398	. Screw - Socket head cap	2	AB
		----- *		
-22	604621	. Lever - Drop, cross feed	1	AB
		Attaching Parts		
-23	604608	. Pin - Drop lever	1	AB
		----- *		
-24	604588	. Lever - Drop, longitudinal feed	1	AB
		Attaching Parts		
-25	604608	. Pin - Drop lever	1	AB
		----- *		
-26	604612	. Plate	2	AB
		Attaching Parts		
-27	3199	. Screw - Socket head cap	6	AB
		----- *		
-28	604624	. Nut - Lock	2	AB
-29	259185	. Spring - Compression	2	AB
-30	2330	. Screw - Hex socket set	2	AB
-31	604596	. Shaft - Feed	2	AB
-32	604611	. Nut - Lock	2	AB
-33	604613	. Bushing - Flange	2	AB
-34	604614	. Collar	2	AB
		Attaching Parts		
-35	143	. Pin - Taper	2	AB
		----- *		
-36	604568	. Bearing - Plain	2	AB
-37	604598	. Gear - Small longitudinal feed	1	AB
-38	604122	. Gear - Large Cross feed	1	AB
-39	605052	. Washer	2	AB
-40	604567	. Sleeve - Feed shaft	2	AB
-41	604535	. Bearing - Plain	2	AB
-42	604599	. Gear - Large longitudinal feed	1	AB
-43	604589	. Gear - Small Cross feed	1	AB
-44	702236	. Lever - Sliding head clamp	1	AB
		Attaching Parts		
-45	78600	. Screw - Hex socket set	1	AB
-46	642	. Pin - Taper	1	AB
		----- *		
-47	603984	. Spring - Compression	1	AB
-48	76645	. Plug - Pipe	1	AB

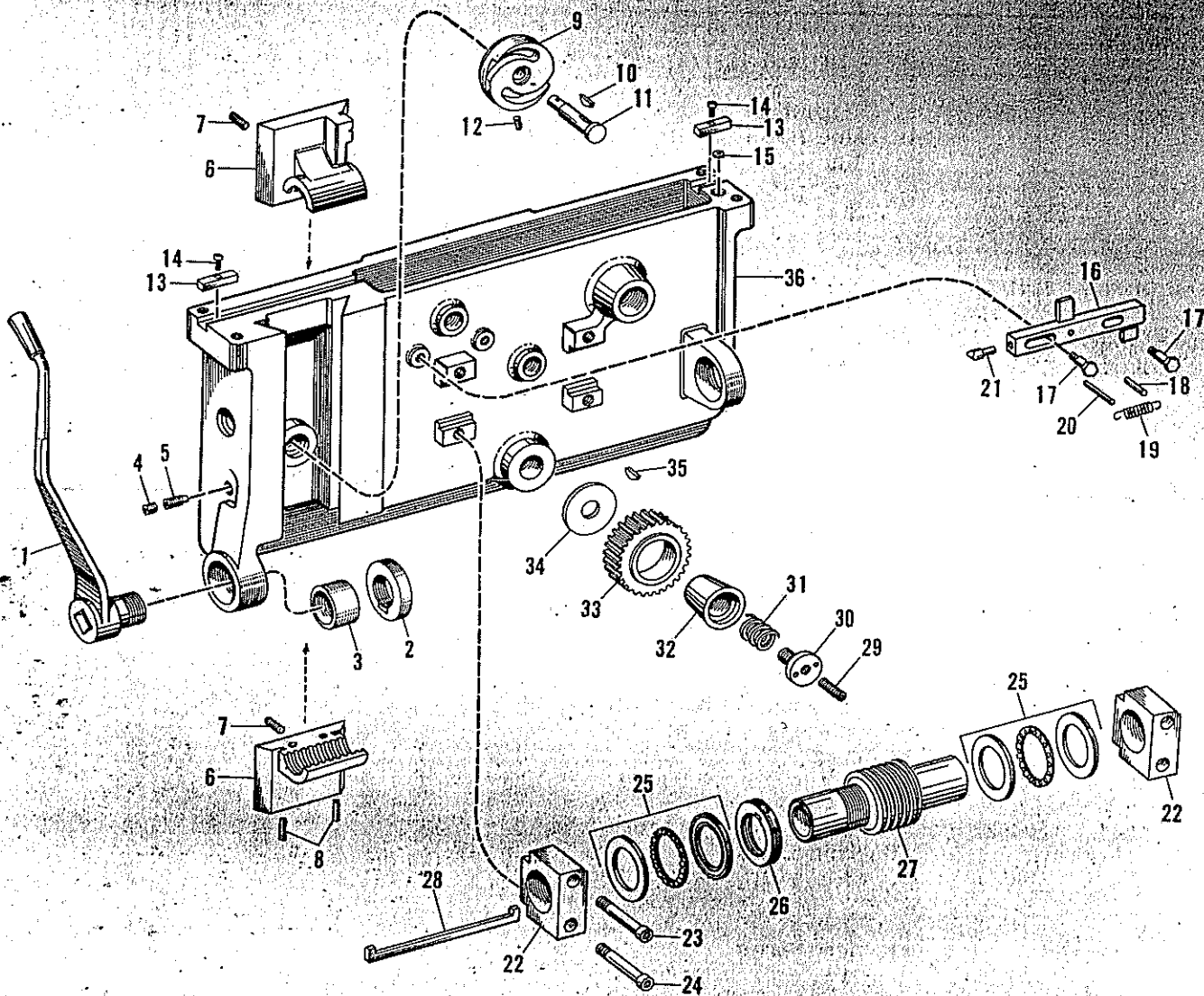

Figure 14. Apron - 10" and 12-1/2" (Rear View)

Figure and Index No.	Part No.	Nomenclature	Units Per Assy.	Application Code
APRON - 10" and 12-1/2" (REAR VIEW) (SEE FIGURE 14)				
14-1	604619	Hub - Handle apron control	1	AB
-2	4190	Attaching Parts Nut - Lock	1	AB
-3	602630	Bushing	1	AB
-4	2356	Screw - Hollow hex lock	1	AB
-5	3233	Screw - Hex socket dog point set	1	AB
-6	604591	Nut - Half (American)	1	AB
-6	604592	Nut - Half (Metric)	1	AB
-7	600108	Stud - Positioning	1	AB
-8	3230	Screw - Hex socket dog point set	2	AB
-9	600640	Cam - Half nut	2	AB
-10	1266	Key - Woodruff	1	AB
-11	604620	Shaft - Half nut cam	1	AB
-12	600641	Stud - Location	1	AB
-13	600458	Key - Apron	2	AB

Figure and Index No.	Part No.	1	2	3	4	5	6	7	Nomenclature	Units Per Assy	Application Code	
APRON - 10" and 12-1/2" (REAR VIEW) (SEE FIGURE 14) (CONT'D)												
14-14	3203	Attaching Parts										
		. Screw - Low socket head cap								2	AB	
-15	600184	. Washer										
-16	604590	. Bar - Interference								1	AB	
		Attaching Parts								1	AB	
-17	601282	. Screw - Hex head shoulder										
		-----*								2	AB	
-18	98826	. Pin - Spring										
-19	140630	. Spring - Extension								1	AB	
-20	98825	. Pin - Spring								1	AB	
-21	601361	. Pin - Interference								1	AB	
-22	604604	. Bracket - Worm								1	AB	
		Attaching Parts								2	AB	
-23	2326	. Screw - Socket head cap										
-24	605156	. Screw - Cap body fit								2	AB	
		-----*								2	AB	
-25	604606	. Bearing - Thrust										
-26	604609	. Nut - Lock (Worm)								2	AB	
-27	604595	. Worm								1	AB	
-28	604618	. Key - Worm								1	AB	
-29	3231	. Screw - Hex socket dog point set								1	AB	
-30	602801	. Screw - Back gear								1	AB	
-31	601409	. Spring								1	AB	
-32	604600	. Cone - Slip clutch								1	AB	
-33	604597	. Worm - Wheel								1	AB	
-34	604545	. Spacer - Main drive shaft								1	AB	
-35	3279	. Key - Hi-pro								1	AB	
-36	604586	. Apron								1	AB	

Figure and Index No.	Part No.	1	2	3	4	5	6	7	Nomenclature	Units Per Assy	Application Code	
APRON - 15" and 18" (FRONT VIEW) (SEE FIGURE 15)												
15-1	607363	. Handwheel										
		Attaching Parts								1	CD	
-2	3479	. Nut - Hex, thin										
		-----*								1	CD	
-3	604167	. Stud - Handle										
-4	604165	. Handle								1	CD	
-5	3280	. Key - Hi-pro								1	CD	
-6	237109	. Bearing - Needle								1	CD	
-7	604024	. Collar - Handwheel								2	CD	
-8	2356	. Screw - Socket head flat point								1	CD	
-9	3233	. Screw - Socket head dog point								1	CD	
-10	604022	. Pinion - Handwheel								1	CD	
-11	604078	. Pinion - Rack								1	CD	
-12	604083	. Gear - Rack pinion								1	CD	
		Attaching Parts								1	CD	
-13	645	. Pin - Taper										
		-----*								1	CD	
-14	604073	. Bearing - Plain										
-15	604071	. Bearing - Plain								1	CD	
-16	3947	. Plug								1	CD	
-17	603520	. Gear - Main drive								1	CD	
-18	93236	. Seal - Oil								1	CD	
-19	603518	. Bearing - Plain								1	CD	
-20	604085	. Housing - Drop lever								1	CD	

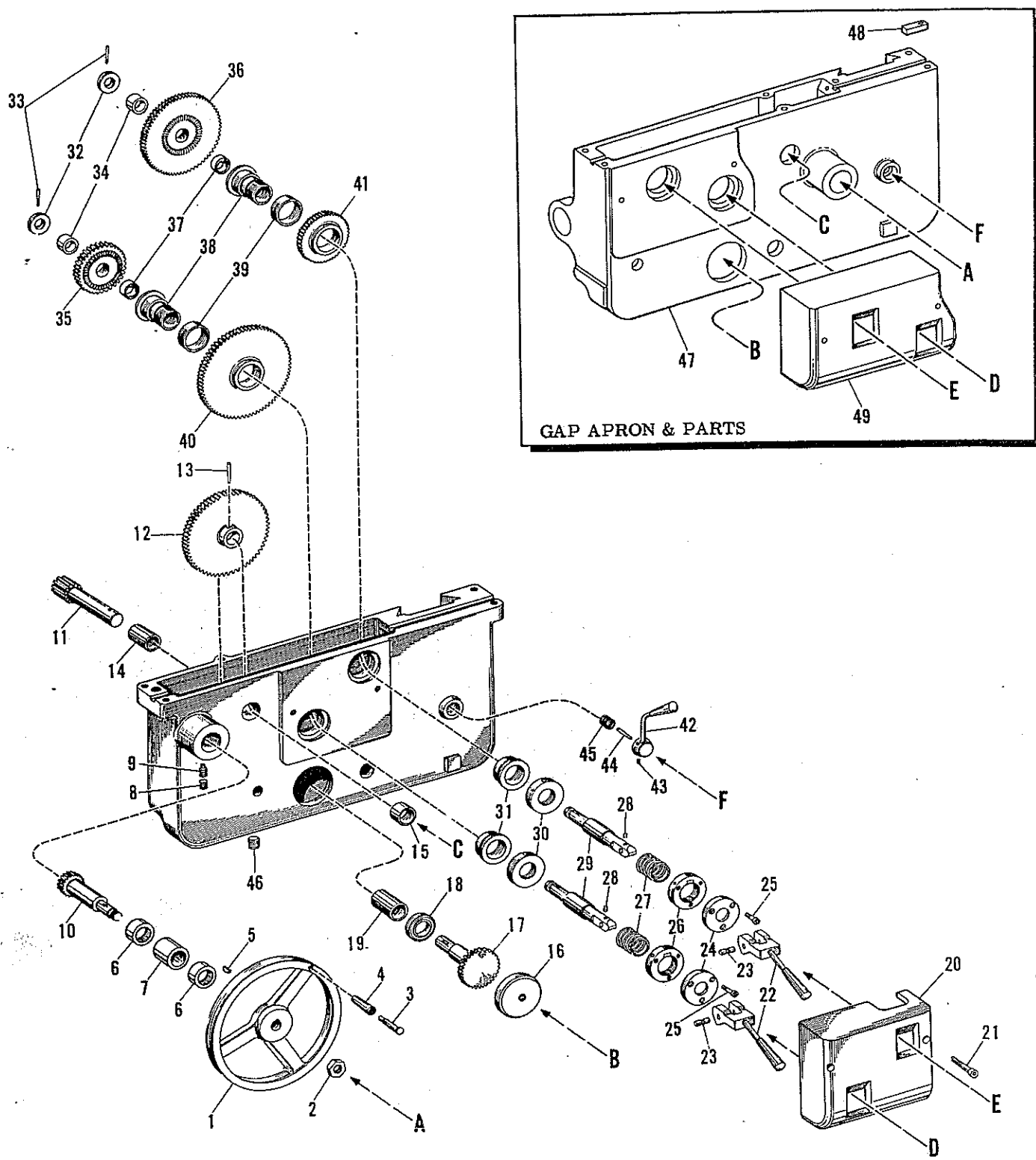

Figure 15. Apron - 15" and 18" (Front View)

Figure and Index No.	Part No.	Nomenclature							Units Per Assy	Application Code
APRON - 15" and 18" (FRONT VIEW) (SEE FIGURE 15) (CONT'D)										
15-21	2329	Attaching Parts								
		. Screw - Socket head cap							2	CD
		----- * -----								
-22	603522	. Lever - Drop							2	CD
-23	604069	Attaching Parts								
		. Pin - Drop lever							2	CD
		----- * -----								
-24	604127	. Plate							2	CD
-25	3199	Attaching Parts								
		. Screw - Low socket head cap							6	CD
		----- * -----								
-26	604074	. Nut - Lock							2	CD
-27	603954	. Spring - Compression							2	CD
-28	2330	. Screw - Hex socket flat set							2	CD
-29	605067	. Shaft - Feed							2	CD
-30	4189	. Nut - Lock							2	CD
-31	604068	. Bushing - Flange							2	CD
-32	239810	. Collar							2	CD
-33	266706	Attaching Parts								
		. Pin - Taper							2	CD
		----- * -----								
-34	604439	. Bearing - Plain							2	CD
-35	604082	. Gear - Small longitudinal feed							1	CD
-36	604080	. Gear - Large cross feed							1	CD
-37	605053	. Washer							2	CD
-38	605066	. Sleeve - Feed shaft							2	CD
-39	604072	. Bearing - Plain							2	CD
-40	604079	. Gear - Large longitudinal feed							1	CD
-41	604081	. Gear - Small cross feed							1	CD
-42	604259	. Lever - Half nut							1	CD
-43	78600	Attaching Parts								
		. Screw - Hex socket flat							1	CD
-44	642	. Pin - Taper							1	CD
		----- * -----								
-45	136-T	. Spring - Compression							1	CD
-46	76645	. Plug Pipe							1	CD
-47	604438	. Apron - Gap only							1	CD
-48	600458	. Key - Gap only							1	CD
-49	604431	. Housing - Drop lever - Gap only							1	CD

Figure and Index No.	Part No.	Nomenclature							Units Per Assy	Application Code
APRON - 15" and 18" (REAR VIEW) (SEE FIGURE 16)										
16-1	604120	. Hub - Handle, apron control							1	CD
-2	4191	Attaching Parts								
		. Nut - Lock							1	CD
		----- * -----								
-3	602540	. Bushing - Control handle							1	CD
-4	1175	. Screw - Socket head flat							1	CD
-5	3455	. Screw - Socket headless dog point							1	CD
-6	604225	. Nut - Half (American)							1	CD
-6	604226	. Nut - Half (Metric)							1	CD
-7	600108	. Stud - Positioning							2	CD
-8	3165	. Screw - Dog point set							2	CD
-9	601694	. Cam - Half nut							1	CD
-10	1266	. Key							1	CD
-11	600449	. Shaft - Half nut cam							1	CD
-12	600448	. Stud - Locking							1	CD
-13	600458	. Key - Apron							2	CD

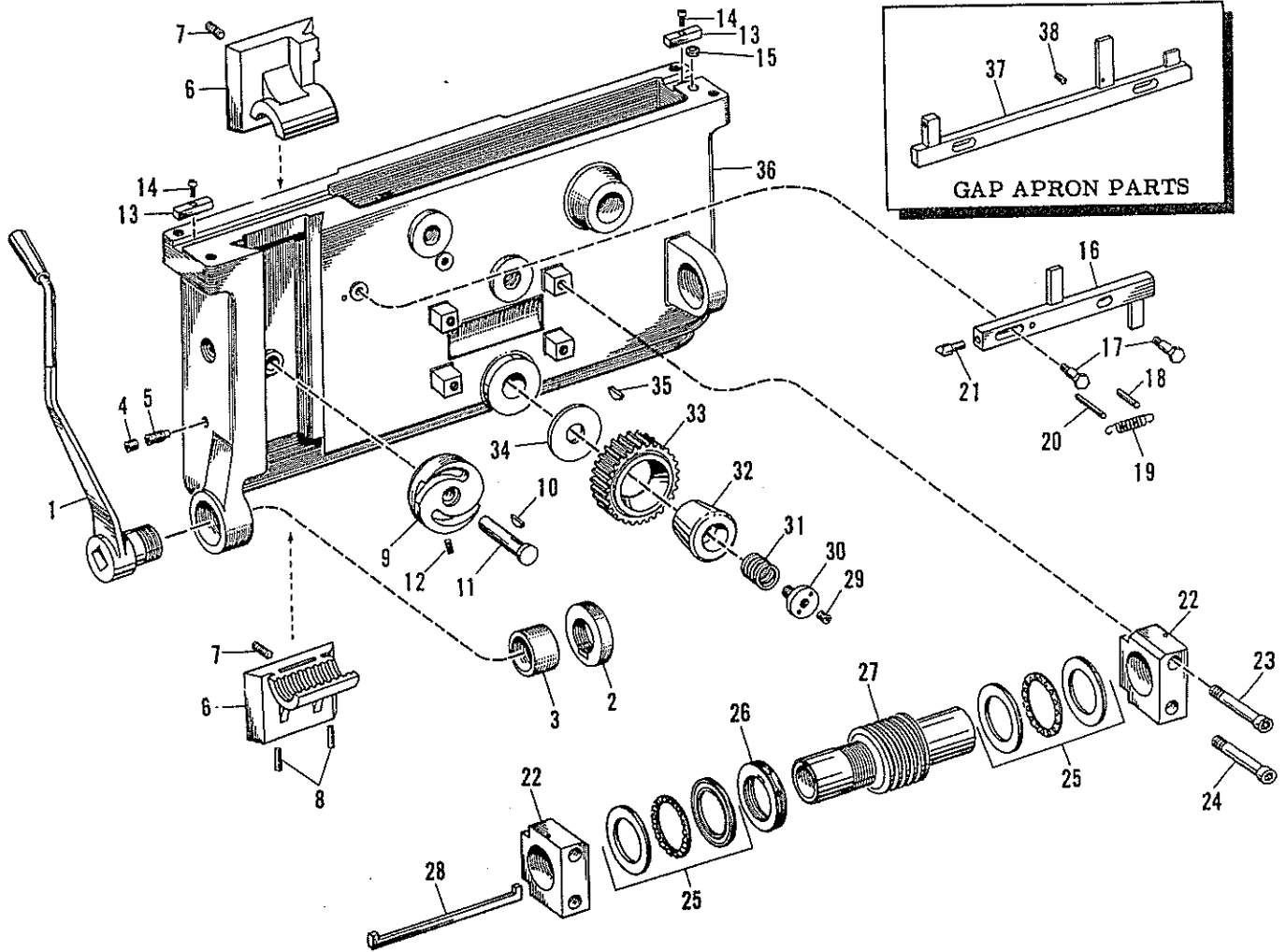

Figure 16. Apron - 15" and 18" (Rear View)

Figure and Index No.	Part No.	1	2	3	4	5	6	7	Nomenclature	Units Per Assy	Application Code
APRON - 15" and 18" (REAR VIEW) (SEE FIGURE 16) (CONT'D)											
Attaching Parts											
16-14	3203								. Screw - Socket head cap	2	CD
									* - - - - -		
-15	600184								. Washer - Seal	1	CD
-16	603521								. Bar - Interference	1	CD
Attaching Parts											
-17	601282								. Screw - Hex head shoulder	2	CD
									* - - - - -		
-18	98826								. Pin - Spring	1	CD
-19	109394								. Spring - Extension	1	CD
-20	98825								. Pin - Spring	1	CD
-21	601361								. Pin - Interference	1	CD
-22	604086								. Bracket - Worm	2	CD
Attaching Parts											
-23	2326								. Screw - Socket head cap	2	CD
-24	605156								. Screw - Cap, body fit	2	CD
									* - - - - -		
-25	604087								. Bearing - Thrust	2	CD
-26	604075								. Nut - Lock (Worm)	1	CD
-27	604084								. Worm	1	CD

Figure and Index No.	Part No.	1	2	3	4	5	6	7	Nomenclature	Units Per Assy	Application Code
APRON - 15" and 18" (REAR VIEW) (SEE FIGURE 16) (CONT'D)											
16-28	604070	.							Key - Worm	1	CD
-29	3231	.							Screw - Hex socket dog point	1	CD
-30	602222	.							Screw - Back gear	1	CD
-31	602218	.							Spring - Cone clutch	1	CD
-32	603519	.							Cone - Slip clutch	1	CD
-33	603695	.							Worm - Wheel	1	CD
-34	604970	.							Spacer - Main drive shaft	1	CD
-35	3280	.							Key - Hi-pro	1	CD
-36	604393	.							Apron - Regular	1	CD
-37	604432	.							Bar - Interference (Gap only)	1	CD
-38	3861	.							Pin - Spring (Gap only)	1	CD

Figure and Index No.	Part No.	1	2	3	4	5	6	7	Nomenclature	Units Per Assy	Application Code
COMPOUND REST AND TOOL POST ASSEMBLIES (SEE FIGURE 17)											
17-1	601465	.							Screw - Tool post	1	A
-1	600596	.							Screw - Tool post	1	B
-1	600162	.							Screw - Tool post	1	CD
-2	601461	.							Ring - Tool post	1	A
-2	604623	.							Ring - Tool post	1	B
-2	603563	.							Ring - Tool post	1	CD
-3	601463	.							Square - Tool post	1	A
-3	600597	.							Square - Tool post	1	B
-3	600163	.							Square - Tool post	1	CD
-4	601462	.							Post - Tool	1	A
-4	600595	.							Post - Tool	1	B
-4	600161	.							Post - Tool	1	CD
-5	601464	.							Wedge - Tool Post	1	A
-5	600599	.							Wedge - Tool Post	1	B
-5	600165	.							Wedge - Tool Post	1	CD
-6	604164	.							Handle	2	All
-7	604541	.							Handle - Top slide	1	AB
-7	604551	.							Handle - Top slide	1	CD
Attaching Parts											
-8	2291	.							Pin - Taper	1	AB
-8	141	.							Pin - Taper	1	CD
- - - - - * - - - - -											
-9	604538	.							Bush - Dial	1	AB
-9	600313	.							Bush - Dial	1	CD
-10	600545	.							Spring - Dial	1	AB
-10	600288	.							Spring - Dial	1	CD
-11	602787	.							Dial - Top slide, American, direct reading	1	AB
-11	602788	.							Dial - Top slide, Metric, direct reading	1	AB
-11	602794	.							Dial - Top slide, American, direct reading	1	CD
-11	602795	.							Dial - Top slide, Metric, direct reading	1	CD
-12	604558	.							Bushing - Top slide	1	AB
-12	600279	.							Bushing - Top slide	1	CD
Attaching Parts											
-13	3218	.							Screw - Socket head cap	2	AB
-13	3399	.							Screw - Socket head cap	2	CD
- - - - - * - - - - -											
-14	600889	.							Shaft - Dial	1	CD
-15	1266	.							Key - Woodruff	1	CD
-16	600311	.							Pinion - Feed	2	CD
Attaching Parts											
-17	140	.							Pin - Taper	2	CD
- - - - - * - - - - -											
-18	2354	.							Screw - Hollow hex lock	1	AB

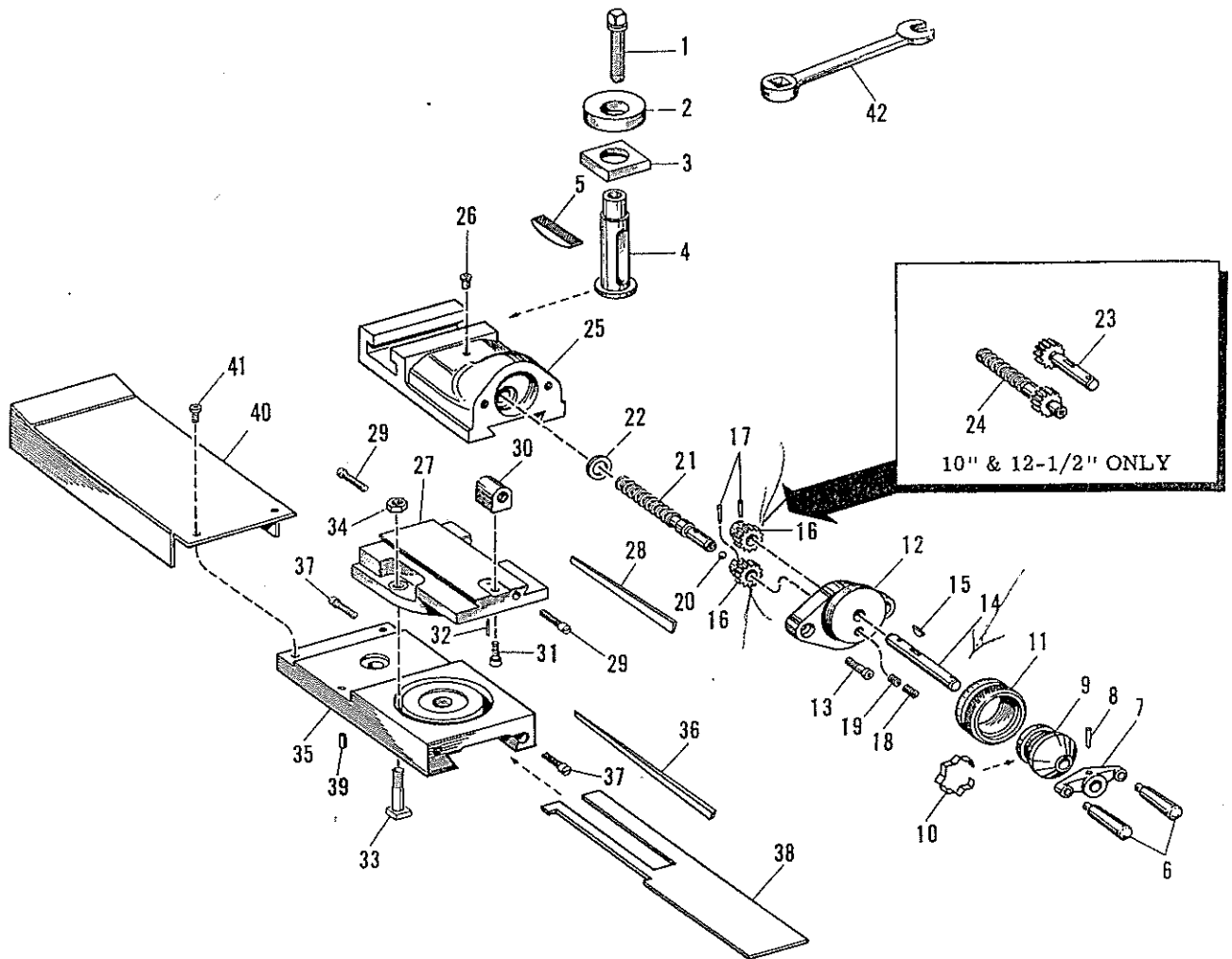

Figure 17. Compound Rest and Tool Post Assemblies

Figure and Index No.	Part No.	1	2	3	4	5	6	7	Nomenclature	Units Per Assy	Application Code
COMPOUND REST AND TOOL POST ASSEMBLIES (SEE FIGURE 17) (CONT'D)											
17-18	2356	.							Screw - Hollow hex lock	1	CD
-19	2332	.							Screw - Hex socket set	1	AB
-19	1911	.							Screw - Hex socket set	1	CD
-20	2290	.							Ball	1	AB
-20	30060	.							Ball	1	CD
-21	603573	.							Screw - Top slide feed, American	1	CD
-21	603574	.							Screw - Top slide feed, Metric	1	CD
-22	604537	.							Bearing - Thrust	1	AB
-22	603577	.							Bearing - Thrust	1	CD
-23	600944	.							Pinion - Dial	1	AB
-24	604559	.							Screw - Top slide feed, American	1	AB
-24	604534	.							Screw - Top slide feed, Metric	1	AB
-25	604548	.							Slide -Top	1	A
-25	604550	.							Slide - Top	1	B
-25	603578	.							Slide - Top	1	CD
-26	69583	.							Oiler - Cup	1	All
-27	604547	.							Swivel	1	A
-27	604551	.							Swivel	1	B
-27	607353	.							Swivel	1	C
-27	607354	.							Swivel	1	D

Figure and Index No.	Part No.	1	2	3	4	5	6	7	Nomenclature	Units Per Assy	Application Code
COMPOUND REST AND TOOL POST ASSEMBLIES (SEE FIGURE 17) (CONT'D)											
17-28	604540	.							Gib - Top slide	1	AB
-28	600890	.							Gib - Top slide	1	CD
									Attaching Parts		
-29	604536	.							Screw - Gib	2	AB
-29	604372	.							Screw - Gib	2	CD
									* - - - - -		
-30	600585	.							Nut - Top slide, American	1	AB
-30	600588	.							Nut - Top slide, Metric	1	AB
-30	604514	.							Nut - Top slide, American	1	CD
-30	604515	.							Nut - Top slide, Metric	1	CD
									Attaching Parts		
-31	3218	.							Screw - Socket head cap	1	AB
-31	3399	.							Screw - Socket head cap	1	CD
-32	228563	.							Pin - Taper	1	A
-32	140	.							Pin - Taper	1	B
-32	141	.							Pin - Taper	1	CD
									* - - - - -		
-33	600591	.							Bolt - Swivel	2	A
-33	601469	.							Bolt - Swivel	2	B
-33	600274	.							Bolt - Swivel	2	C
-33	600210	.							Bolt - Swivel	2	D
-34	3473	.							Nut - Thin hex	2	AB
-34	3474	.							Nut - Thin hex	2	C
-34	3479	.							Nut - Thin hex	2	D
-35	604549	.							Slide - Cross	1	AB
-35	603567	.							Slide - Cross	1	CD
-36	600942	.							Gib - Cross slide	1	AB
-36	600891	.							Gib - Cross slide	1	CD
									Attaching Parts		
-37	604536	.							Screw - Gib	2	AB
-37	600273	.							Screw - Gib	2	CD
									* - - - - -		
-38	604582	.							Guard - Cross slide front	1	AB
-38	603912	.							Guard - Cross slide front	1	CD
-39	3383	.							Pin - Straight	1	All
-40	600584	.							Guard - Cross slide	1	AB
-40	600316	.							Guard - Cross slide	1	C
-40	603564	.							Guard - Cross slide	1	D
									Attaching Parts		
-41	234042	.							Screw - Low socket head cap	2	AB
-41	3198	.							Screw - Low head socket cap	2	CD
									* - - - - -		
-42	602946	.							Wrench - Tool post	1	AB
-42	601345	.							Wrench - Tool post	1	CD

Figure and Index No.	Part No.	1	2	3	4	5	6	7	Nomenclature	Units Per Assy	Application Code
CARRIAGE AND CROSS FEED ASSEMBLIES (SEE FIGURE 18)											
18-1	603971	.							Nut - Cross feed, American	1	AB
-1	603970	.							Nut - Cross feed, Metric	1	AB
-1	603575	.							Nut - Cross feed, American	1	CD
-1	603576	.							Nut - Cross feed, Metric	1	CD
									Attaching Parts		
-2	603967	.							Screw - Cross feed nut	1	AB
-2	4169	.							Screw - Cross feed nut	1	CD
									* - - - - -		
-3	2333	.							Screw - Hex socket flat point set	1	AB
-3	2334	.							Screw - Hex socket flat point set	1	CD
-4	600548	.							Gib - Rear	1	AB

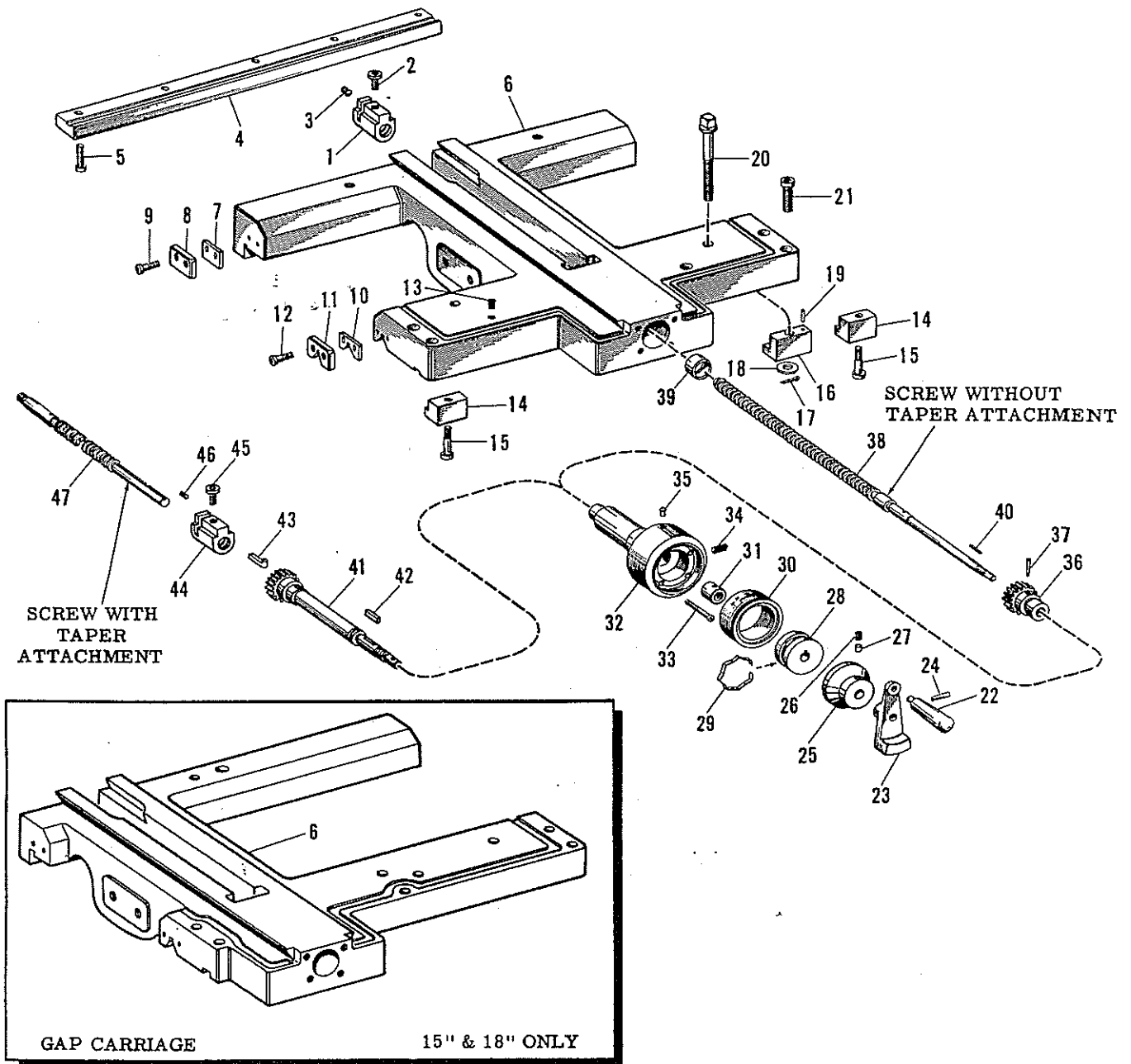

Figure 18. Carriage and Cross Feed Assemblies

Figure and Index No.	Part No.	1	2	3	4	5	6	7	Nomenclature	Units Per Assy	Application Code
CARRIAGE AND CROSS FEED ASSEMBLIES (SEE FIGURE 18) (CONT'D)											
18-4	600292	.							Gib - Rear	1	CD
-4	601302	.							Gib - Rear, Gap only	1	CD
									Attaching Parts		
-5	3396	.							Screw - Socket head cap	5	AB
-5	3266	.							Screw - Socket head cap	5	CD
									* - - - - -		
-6	604554	.							Carriage	1	A
-6	604555	.							Carriage	1	B
-6	604003	.							Carriage	1	C
-6	603569	.							Carriage	1	D

Figure and Index No.	Part No.	1	2	3	4	5	6	7	Nomenclature	Units Per Assy	Application Code
CARRIAGE AND CROSS FEED ASSEMBLIES (SEE FIGURE 18) (CONT'D)											
18-6	604004	.							Carriage - Gap only	1	C
-6	603570	.							Carriage - Gap only	1	D
-7	600542	.							Pad - Shear wiper rear	2	AB
-7	600285	.							Pad - Shear wiper rear	2	CD
-8	600541	.							Wiper - Shear, rear	2	AB
-8	600284	.							Wiper - Shear, rear	2	CD
Attaching Parts											
-9	3199	.							Screw - Low socket head cap	4	All
- - - - - * - - - - -											
-10	600528	.							Pad - Shear wiper front	2	AB
-10	600283	.							Pad - Shear wiper front	2	CD
-11	600527	.							Wiper - Shear, front	2	AB
-11	600282	.							Wiper - Shear, front	2	CD
Attaching Parts											
-12	3199	.							Screw - Low socket head cap	4	All
- - - - - * - - - - -											
-13	220784	.							Plug - Pipe	1	All
-14	600552	.							Gib - Front	2	AB
-14	600295	.							Gib - Front	2	CD
Attaching Parts											
-15	3397	.							Screw - Socket head cap	2	AB
-15	3251	.							Screw - Socket head cap	2	CD
- - - - - * - - - - -											
-16	600549	.							Clamp - Carriage	1	AB
-16	600293	.							Clamp - Carriage	1	CD
Attaching Parts											
-17	2095	.							Pin - Cotter	1	All
-18	3441	.							Washer	1	AB
-18	3442	.							Washer	1	CD
-19	3541	.							Pin - Straight	1	All
-20	604528	.							Screw - Carriage clamp	1	AB
-20	603571	.							Screw - Carriage clamp	1	CD
- - - - - * - - - - -											
-21	3401	.							Screw - Socket head cap	4	AB
-21	3405	.							Screw - Socket head cap	6	CD
-22	604527	.							Handle	1	AB
-22	605158	.							Handle	1	CD
-23	604530	.							Crank - Cross feed	1	AB
-23	605196	.							Crank - Cross feed	1	CD
Attaching Parts											
-24	140	.							Pin - Taper	1	AB
-24	143	.							Pin - Taper	1	CD
- - - - - * - - - - -											
-25	602676	.							Nut - Lock	1	AB
-25	602664	.							Nut - Lock	1	CD
Attaching Parts											
-26	2330	.							Screw - Hex socket flat point set	1	AB
-26	2331	.							Screw - Hex socket flat point set	1	CD
-27	1994	.							Plug - Brass	1	All
- - - - - * - - - - -											
-28	604529	.							Bushing - Cross feed dial	1	AB
-28	603203	.							Bushing - Cross feed dial	1	CD
-29	604539	.							Spring - Dial	1	AB
-29	603202	.							Spring - Dial	1	CD
-30	604526	.							Dial - Cross feed, American, direct reading	1	AB
-30	604560	.							Dial - Cross feed, Metric, direct reading	1	AB
-30	603201	.							Dial - Cross feed, American, direct reading	1	CD
-30	603208	.							Dial - Cross feed, Metric, direct reading	1	CD
-31	604533	.							Bearing - Cross feed screw	1	AB
-31	604156	.							Bearing - Cross feed screw	1	CD
-32	604546	.							Bushing - Cross feed	1	AB
-32	603415	.							Bushing - Cross feed	1	CD

Figure and Index No.	Part No.	1	2	3	4	5	6	7	Nomenclature	Units Per Assy	Application Code
CARRIAGE AND CROSS FEED ASSEMBLIES (SEE FIGURE 18) (CONT'D)											
Attaching Parts											
18-33	3217	.							Screw - Socket head cap	4	AB
-33	2300	.							Screw - Socket head cap	4	CD
									* - - - - -		
-34	78600	.							Screw - Hex socket flat point set	1	AB
-34	1911	.							Screw - Hex socket flat point set	1	CD
-35	60062	.							Cup - Oil	1	All
-36	604525	.							Pinion - Cross feed	1	AB
-36	602678	.							Pinion - Cross feed	1	CD
Attaching Parts											
-37	140	.							Pin - Taper	1	AB
-37	663	.							Pin - Taper	1	CD
									* - - - - -		
-38	604544	.							Screw - Cross feed, American	1	AB
-38	604543	.							Screw - Cross feed, Metric	1	AB
-38	603413	.							Screw - Cross feed, American	1	CD
-38	603414	.							Screw - Cross feed, Metric	1	CD
-39	607406	.							Bush - Drive	1	AB
-39	607407	.							Bush - Drive	1	CD
-40	864	.							Key	1	All
-41	604572	.							Pinion - Cross feed, taper attachment	1	AB
-41	604144	.							Pinion - Cross feed, taper attachment	1	CD
-42	864	.							Key	1	All
-43	600558	.							Key - Tit	1	AB
-43	602448	.							Key - Tit	1	CD
-44	603971	.							Nut - Cross feed, American	1	AB
-44	604531	.							Nut - Cross feed, Metric	1	AB
-44	603575	.							Nut - Cross feed, American	1	CD
-44	603576	.							Nut - Cross feed, Metric	1	CD
Attaching Parts											
-45	603967	.							Screw - Cross feed nut	1	AB
-45	4169	.							Screw - Cross feed nut	1	CD
									* - - - - -		
-46	2333	.							Screw - Hex socket flat point set	1	AB
-46	2334	.							Screw - Hex socket flat point set	1	CD
-47	604573	.							Screw - Cross feed, American, taper attachment	1	A
-47	604574	.							Screw - Cross feed, Metric, taper attachment	1	A
-47	604575	.							Screw - Cross feed, American, taper attachment	1	B
-47	604576	.							Screw - Cross feed, Metric, taper attachment	1	B
-47	604145	.							Screw - Cross feed, American, taper attachment	1	C
-47	604146	.							Screw - Cross feed, Metric, taper attachment	1	C
-47	604147	.							Screw - Cross feed, American, taper attachment	1	D
-47	604148	.							Screw - Cross feed, Metric, taper attachment	1	D

Figure and Index No.	Part No.	1	2	3	4	5	6	7	Nomenclature	Units Per Assy	Application Code
TAPER ATTACHMENT (SEE FIGURE 19)											
19-1	602752	.							Bar	1	AB
-1	600924	.							Bar	1	CD
-2	602054	.							Stud	1	AB
-2	602055	.							Stud	1	CD
-3	3441	.							Washer	1	AB
-3	3442	.							Washer	1	CD
-4	3473	.							Nut - Thin hex	1	AB
-4	3474	.							Nut - Thin hex	1	CD
-5	600669	.							Shoe - Top slide	1	AB
-5	600488	.							Shoe - Top slide	1	CD
-6	600681	.							Screw - Shoulder	1	AB
-6	600502	.							Screw - Shoulder	1	CD
-7	600670	.							Gib - Top slide shoe	1	AB

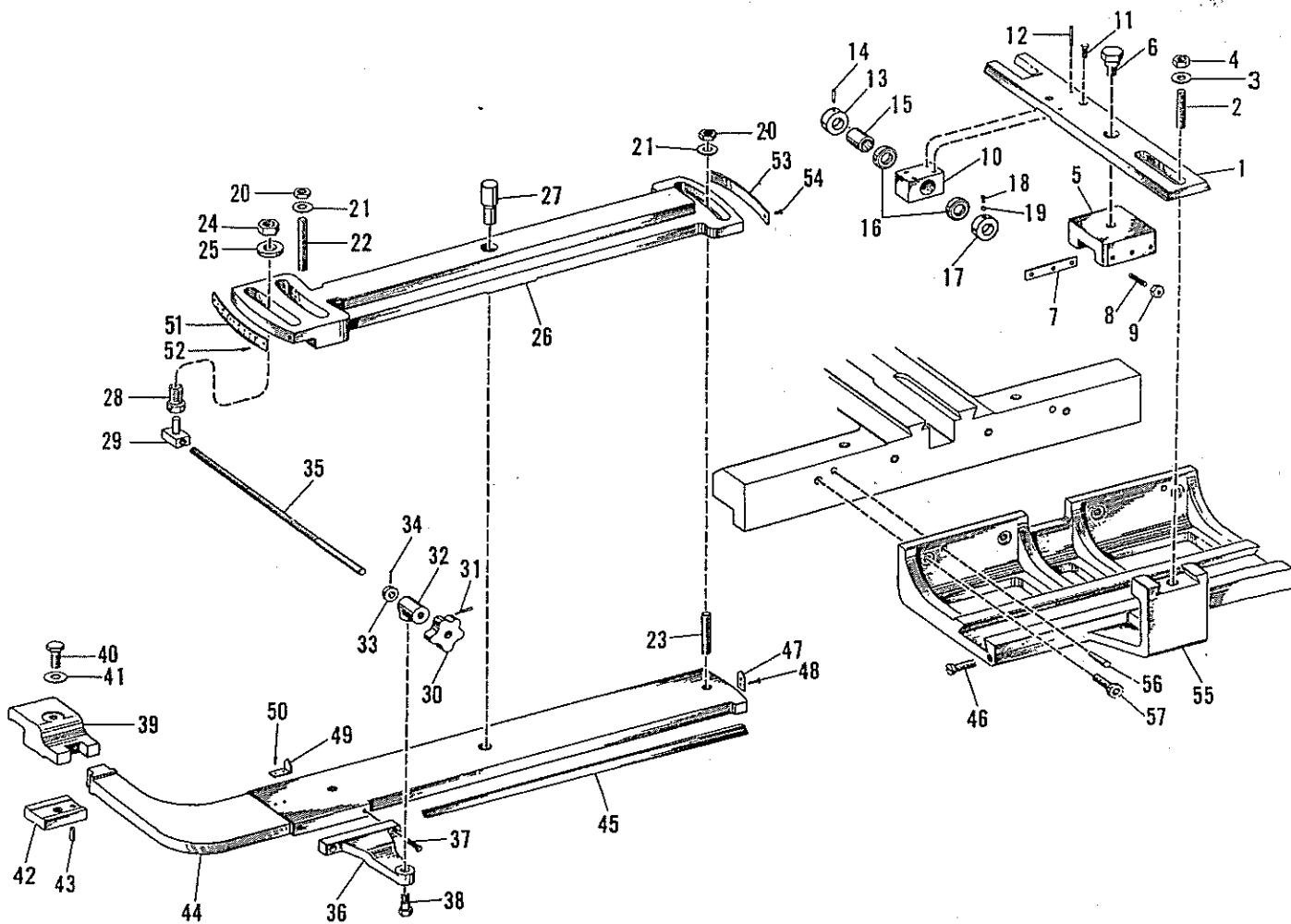

Figure 19. Taper Attachment

Figure and Index No.	Part No.	Nomenclature	Units Per Assy	Application Code
		1 2 3 4 5 6 7		
TAPER ATTACHMENT (SEE FIGURE 19) (CONT'D)				
19-7	600489	. Gib - Top slide shoe	1	CD
		Attaching Parts		
-8	600671	. Screw - Set, gib	2	AB
-8	3165	. Screw - Set, gib	3	CD
-9	2280	. Nut - Hex	2	AB
-9	3472	. Nut - Hex	3	CD
		-----*		
-10	600930	. Bracket - Feed screw bearing	1	AB
-10	600495	. Bracket - Feed screw bearing	1	CD
		Attaching Parts		
-11	3204	. Screw - Low socket head cap	2	AB
-11	3210	. Screw - Low socket head cap	2	CD
-12	3270	. Pin - Straight	2	AB
-12	3541	. Pin - Straight	2	CD
		-----*		
-13	600677	. Collar - Feed screw	1	AB
-13	600496	. Collar - Feed screw	1	CD
		Attaching Parts		
-14	140	. Pin - Taper	1	AB
-14	143	. Pin - Taper	1	CD
		-----*		

Figure and Index No.	Part No.	1	2	3	4	5	6	7	Nomenclature	Units Per Assy	Application Code
TAPER ATTACHMENT (SEE FIGURE 19) (CONT'D)											
19-15	240669	.							Bushing - Cross feed screw	1	AB
-15	223048	.							Bushing - Cross feed screw	1	CD
-16	602762	.							Bearing - Ball thrust	2	AB
-16	700418	.							Bearing - Ball thrust	2	CD
-17	602763	.							Nut - Adjusting	1	AB
-17	602751	.							Nut - Adjusting	1	CD
Attaching Parts											
-18	2353	.							Screw - Low socket set	1	AB
-18	2332	.							Screw - Low socket set	1	CD
-19	600436	.							Plug - Brass	1	AB
-19	1550	.							Plug - Brass	1	CD
* - - - - -											
-20	3478	.							Nut - Hex	2	AB
-20	3479	.							Nut - Hex	2	CD
-21	3441	.							Washer	2	AB
-21	3442	.							Washer	2	CD
-22	200160	.							Stud	1	AB
-22	48955	.							Stud	1	CD
-23	75946	.							Stud	1	AB
-23	81693	.							Stud	1	CD
-24	3475	.							Nut - Hex	1	AB
-24	3476	.							Nut - Hex	1	CD
-25	1040	.							Washer	1	AB
-25	764	.							Washer	1	CD
-26	600665	.							Slide - Top	1	AB
-26	600484	.							Slide - Top	1	CD
-27	600666	.							Stud - Swivel	1	AB
-27	600485	.							Stud - Swivel	1	CD
-28	601277	.							Bushing - Index screw	1	AB
-28	601276	.							Bushing - Index screw	1	CD
-29	600668	.							Nut - Index screw	1	AB
-29	600487	.							Nut - Index screw	1	CD
-30	600675	.							Knob - Star	1	AB
-30	601337	.							Knob - Star	1	CD
Attaching Parts											
-31	2291	.							Pin - Taper	1	AB
-31	663	.							Pin - Taper	1	CD
* - - - - -											
-32	600902	.							Swivel - Index screw	1	AB
-32	600896	.							Swivel - Index screw	1	CD
-33	96952	.							Collar - Index screw	1	AB
-33	103103	.							Collar - Index screw	1	CD
Attaching Parts											
-34	140	.							Pin - Taper	1	AB
-34	2291	.							Pin - Taper	1	CD
* - - - - -											
-35	600673	.							Screw - Index	1	AB
-35	600491	.							Screw - Index	1	CD
-36	600901	.							Bracket - Index screw	1	AB
-36	600895	.							Bracket - Index screw	1	CD
Attaching Parts											
-37	3246	.							Screw - Socket head cap	2	AB
-37	3396	.							Screw - Socket head cap	2	CD
* - - - - -											
-38	600903	.							Screw - Shoulder	1	AB
-38	600796	.							Screw - Shoulder	1	CD
-39	600687	.							Cap - Locating clamp	1	AB
-39	600509	.							Cap - Locating clamp	1	CD
-40	600908	.							Screw - Hex head cap	1	AB
-40	601443	.							Screw - Hex head cap	1	CD
-41	3442	.							Washer	1	AB
-41	1040	.							Washer	1	CD

Figure and Index No.	Part No.	1	2	3	4	5	6	7	Nomenclature	Units Per Assy	Application Code
TAPER ATTACHMENT (SEE FIGURE 19) (CONT'D)											
19-42	600686	.							Clamp - Locating	1	AB
-42	600508	.							Clamp - Locating	1	CD
-43	3270	.							Pin - Straight	1	AB
-43	3431	.							Pin - Straight	1	CD
-44	600899	.							Slide - Bottom	1	AB
-44	600893	.							Slide - Bottom	1	CD
-45	600900	.							Gib	1	AB
-45	600894	.							Gib	1	CD
-46	604536	.							Screw - Gib	2	AB
-46	604372	.							Screw - Gib	2	CD
-47	600685	.							Pointer - Degree	1	AB
-47	600507	.							Pointer - Degree	1	CD
Attaching Parts											
-48	3459	.							Screw - Round head	2	All
-----*											
-49	600683	.							Pointer - Taper per foot	1	AB
-49	600505	.							Pointer - Taper per foot	1	CD
Attaching Parts											
-50	3459	.							Screw - Round head	2	All
-----*											
-51	600688	.							Scale - Index, taper per foot, American	1	AB
-51	600689	.							Scale - Index, taper per foot, Metric	1	AB
-51	600504	.							Scale - Index, taper per foot, American	1	CD
-51	600518	.							Scale - Index, taper per foot, Metric	1	CD
Attaching Parts											
-52	3459	.							Screw - Round head	2	All
-----*											
-53	600684	.							Scale - Degrees	1	AB
-53	600506	.							Scale - Degrees	1	CD
Attaching Parts											
-54	3459	.							Screw - Round head	2	All
-----*											
-55	604622	.							Bracket	1	AB
-55	604384	.							Bracket	1	CD
Attaching Parts											
-56	663	.							Pin - Taper	2	All
-57	3266	.							Screw - Socket head cap	4	AB
-57	3403	.							Screw - Socket head cap	4	CD

Figure and Index No.	Part No.	1	2	3	4	5	6	7	Nomenclature	Units Per Assy	Application Code
APRON AND CARRIAGE LUBRICATION SYSTEM (SEE FIGURE 20)											
20-1	600180	.							Lubricator	1	All
-2	600181	.							Bushing - Compression	4	All
-2	600182	.							Sleeve - Compression	4	All
-3	604607	.							Tubing - Oil	1	AB
-3	603423	.							Tubing - Oil, regular	1	CD
-3	603422	.							Tubing - Oil, gap	1	CD
-4	600937	.							Tee - Adapter	1	All
-5	600936	.							Bar - Junction	1	All
Attaching Parts											
-6	3246	.							Screw - Socket head cap	2	All
-----*											
-7	600186	.							Plug - Closure	1	All
-8	600946	.							Unit - Metering	2	All
-9	600188	.							Nut - Compression	2	All
-9	600189	.							Sleeve - Compression	2	All
-10	600185	.							Bar - Junction	1	All

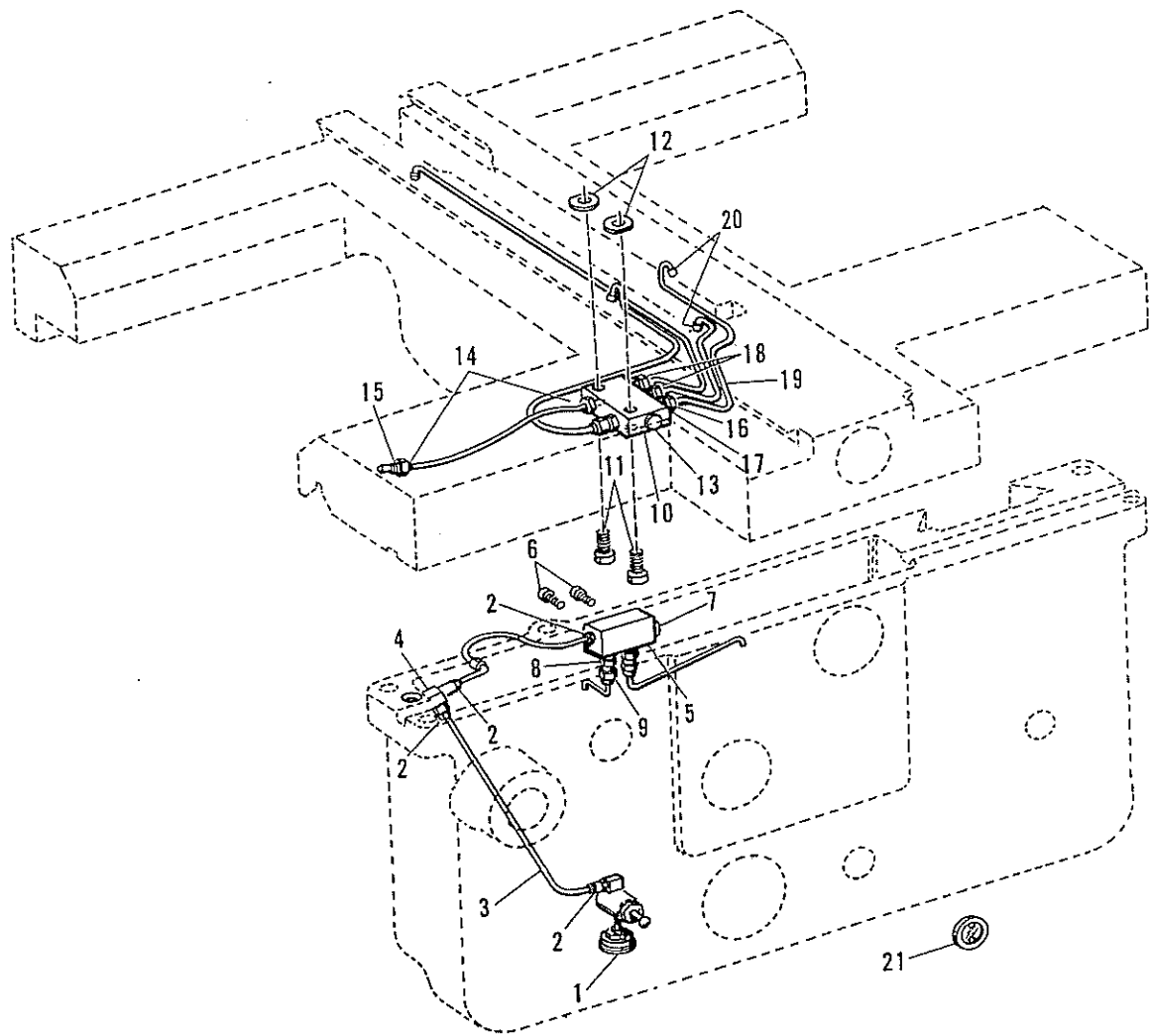

Figure 20. Apron and Carriage Lubrication System

Figure and Index No.	Part No.	Nomenclature							Units Per Assy	Application Code
		1	2	3	4	5	6	7		
APRON AND CARRIAGE LUBRICATION SYSTEM (SEE FIGURE 20) (CONT'D)										
Attaching Parts										
20-11	3246	. Screw - Socket head cap							2	All
		-----*								
-12	600196	. Washer							2	All
-13	600186	. Plug - Closure							3	All
-14	600181	. Bushing - Compression							2	All
-14	600182	. Sleeve - Compression							2	All
-15	600183	. Adapter - Straight							1	All
-16	600188	. Nut - Compression							4	All
-16	600189	. Sleeve - Compression							4	All
-17	600187	. Unit - Metering							2	All
-18	600191	. Unit - Metering							2	All
-19	604570	. Tubing - Oil							1	AB
-19	604248	. Tubing - Oil							1	CD
-20	600192	. Bushing - Drive							4	All
-21	237701	. Gage - Oil sight							1	All

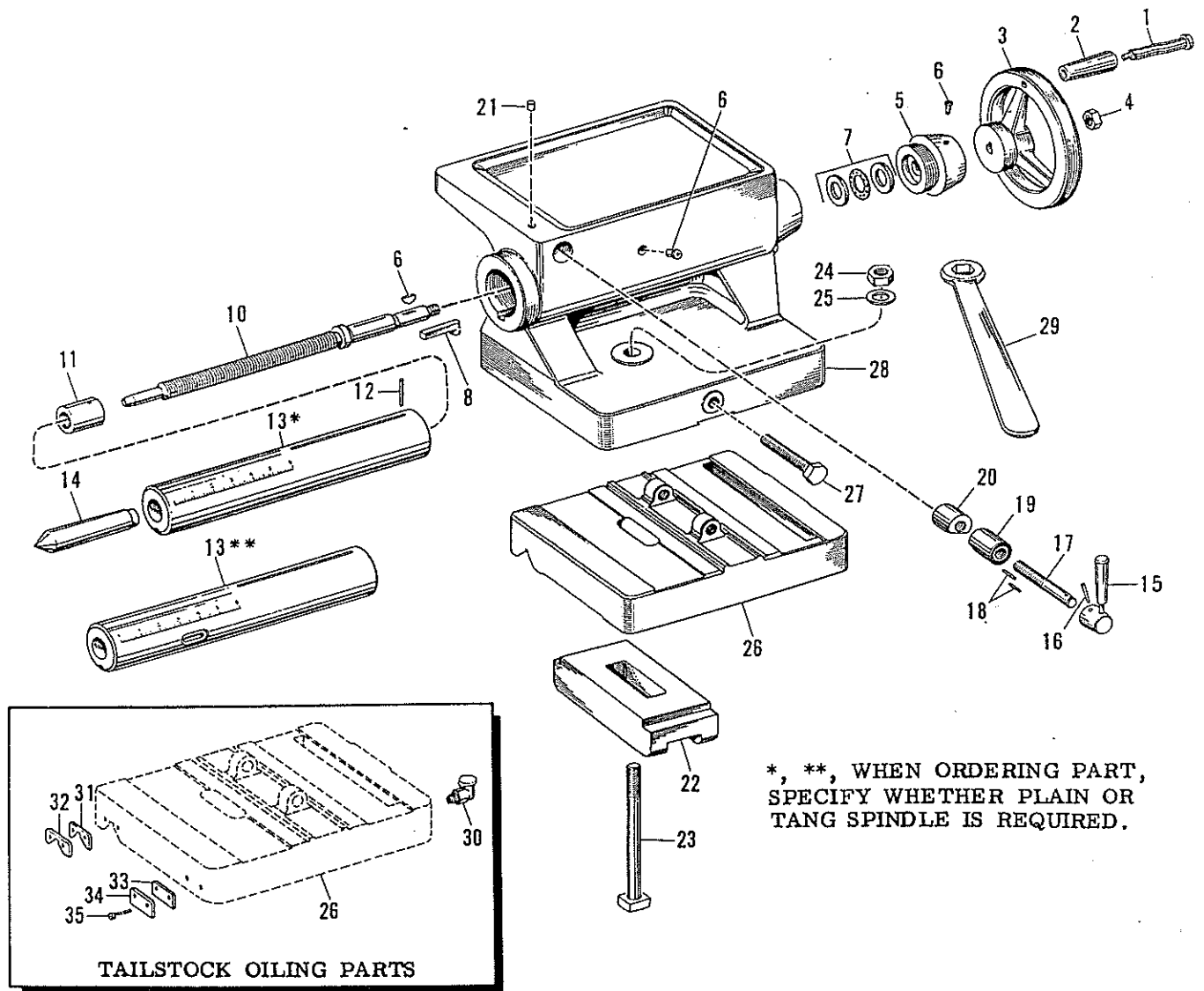

Figure 21. Tailstock Assembly

Figure and Index No.	Part No.	Nomenclature	Units Per Assy	Application Code
TAILSTOCK ASSEMBLY (SEE FIGURE 21)				
21-1	604412	. Stud - Handle	1	AB
-1	605224	. Stud - Handle	1	CD
-2	604411	. Handle	1	AB
-2	605225	. Handle	1	CD
-3	604407	. Handwheel	1	AB
-3	605231	. Handwheel	1	CD
Attaching Parts				
-4	3473	. Nut - Thin hex	1	AB
-4	3479	. Nut - Thin hex	1	CD
-----*				
-5	604413	. Cap - End	1	AB
-5	603395	. Cap - End	1	CD
-6	60062	. Cup - Oil	2	All
-7	104207	. Bearing - Ball thrust	1	AB
-7	89134	. Bearing - Ball thrust	1	CD
-8	603397	. Key - Tit	1	All

Figure and Index No.	Part No.	1 2 3 4 5 6 7	Nomenclature	Units Per Assy	Application Code
TAILSTOCK ASSEMBLY (SEE FIGURE 21) (CONT'D)					
21-9	3279	.	Key - Hi-pro	1	AB
-9	3280	.	Key - Hi-pro	1	CD
-10	604406	.	Screw - Spindle	1	AB
-10	603394	.	Screw - Spindle	1	CD
-11	600166	.	Nut - Spindle	1	AB
-11	600004	.	Nut - Spindle	1	CD
-12	140	.	Pin - Taper	1	AB
-12	642	.	Pin - Taper	1	CD
-13	604404	.	Spindle - Regular *	1	A
-13	604405	.	Spindle - Tang slot (On demand) **	1	A
-13	604402	.	Spindle - Regular *	1	B
-13	604403	.	Spindle - Tang slot (On demand) **	1	B
-13	603404	.	Spindle - Regular *	1	C
-13	603405	.	Spindle - Tang slot (On demand) **	1	C
-13	603391	.	Spindle - Regular *	1	D
-13	603393	.	Spindle - Tang slot (On demand) **	1	D
-14	603952	.	Center - No. 2 Morse taper	1	A
-14	600242	.	Center - No. 3 Morse taper	1	BC
-14	601373	.	Center - No. 4 Morse taper	1	D
-15	604410	.	Handle	1	AB
-15	605227	.	Handle	1	CD
Attaching Parts					
-16	143	.	Pin - Taper	1	AB
-16	642	.	Pin - Taper	1	CD
- - - - - * - - - - -					
-17	604409	.	Screw - Spindle clamp	1	AB
-17	603398	.	Screw - Spindle clamp	1	CD
-18	3383	.	Pin - Straight	2	AB
-18	3636	.	Pin - Straight	2	CD
-19	601637	.	Bushing - Spindle clamp	1	AB
-19	603561	.	Bushing - Spindle clamp	1	CD
-20	600535	.	Nut - Spindle clamp	1	AB
-20	600166	.	Nut - Spindle clamp, tang slot (On demand)	1	AB
-20	601647	.	Nut - Spindle clamp	1	CD
-20	603561	.	Nut - Spindle clamp, tang slot (On demand)	1	CD
-21	2268	.	Plug	1	AB
-21	1962	.	Plug	1	CD
-22	600179	.	Clamp - Tailstock	1	A
-22	600539	.	Clamp - Tailstock	1	B
-22	600014	.	Clamp - Tailstock	1	C
-22	603392	.	Clamp - Tailstock	1	D
Attaching Parts					
-23	601631	.	Bolt - Tee	1	A
-23	604408	.	Bolt - Tee	1	B
-23	603408	.	Bolt - Tee	1	C
-23	603396	.	Bolt - Tee	1	D
-24	3480	.	Nut - Hex full	1	AB
-24	3481	.	Nut - Hex full	1	CD
-25	1045	.	Washer	1	AB
-25	764	.	Washer	1	CD
- - - - - * - - - - -					
-26	604399	.	Bottom - Tailstock, regular	1	A
-26	604398	.	Bottom - Tailstock, oiling (On demand)	1	A
-26	604400	.	Bottom - Tailstock, regular	1	B
-26	604401	.	Bottom - Tailstock, oiling (On demand)	1	B
-26	603402	.	Bottom - Tailstock, regular	1	C
-26	603403	.	Bottom - Tailstock, oiling (On demand)	1	C
-26	603388	.	Bottom - Tailstock, regular	1	D
-26	603389	.	Bottom - Tailstock, oiling (On demand)	1	D
-27	604512	.	Screw - Tailstock offset	2	AB
-27	212211	.	Screw - Tailstock offset	2	CD
-28	604396	.	Top - Tailstock	1	A
-28	604397	.	Top - Tailstock	1	B
-28	603401	.	Top - Tailstock	1	C

*, **, When ordering part specify whether plain or tang spindle is required.

Figure and Index No.	Part No.	Nomenclature	Units Per Assy	Application Code
TAILSTOCK ASSEMBLY (SEE FIGURE 21) (CONT'D)				
21-28	603387	. Top - Tailstock	1	D
-29	60062	. Cup - Oil	1	All
-30	600968	. Wrench - Hex box	1	AB
-30	600967	. Wrench - Hex box	1	CD
-31	604513	. Cup - Oil (On demand)	1	AB
-31	228994	. Cup - Oil (On demand)	1	CD
-32	600528	. Pad - Wiper, shear front (On demand)	2	AB
-32	600283	. Pad - Wiper, shear front (On demand)	2	CD
-33	600527	. Wiper - Shear front (On demand)	2	AB
-33	600282	. Wiper - Shear front (On demand)	2	CD
-34	600542	. Pad - Wiper, shear rear (On demand)	2	AB
-34	600285	. Pad - Wiper, shear rear (On demand)	2	CD
-35	600541	. Wiper - Shear rear (On demand)	2	AB
-35	600284	. Wiper - Shear rear (On demand)	2	CD
Attaching Parts				
-36	3199	. Screw - Low socket head set	8	All

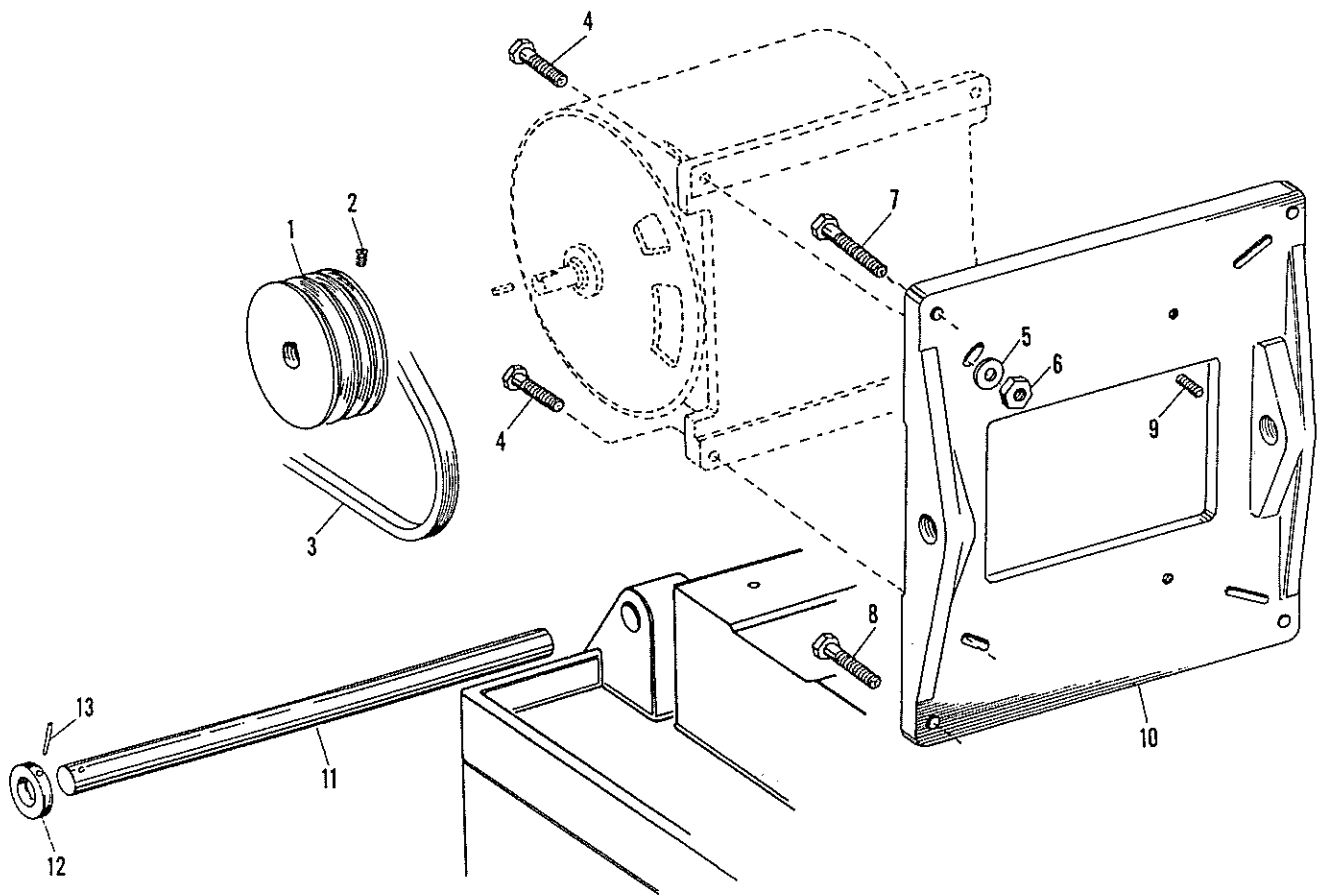

Figure 22. Motor Drive Assembly

Figure and Index No.	Part No.	Nomenclature	Units Per Assy	Application Code
MOTOR DRIVE ASSEMBLY (SEE FIGURE 22)				
22-1	*	. Pulley - Motor	1	All
-2	1911	. Screw - Hex socket set	1	All
-2	2301	. Screw - Hex socket set	1	All
-2	3211	. Screw - Hex socket set	1	All

Figure and Index No.	Part No.	Nomenclature							Units Per Assy	Application Code
		1	2	3	4	5	6	7		
MOTOR DRIVE ASSEMBLY (SEE FIGURE 22) (CONT'D)										
22-3	604699	.	Belt - "V", Standard speed range (35-1200)						2	A
-3	604697	.	Belt - "V", High speed range (53-1800)						2	A
-3	604698	.	Belt - "V", Standard speed range (35-1200)						2	B
-3	604696	.	Belt - "V", High speed range (53-1800)						2	B
-3	604808	.	Belt - "V", Standard speed range (25-980)						3	C
-3	604809	.	Belt - "V", High speed range (37-1470)						3	C
-3	604810	.	Belt - "V", Standard speed range (25-980)						3	D
-3	604811	.	Belt - "V", High speed range (37-1470)						3	D
-4	3320	.	Screw - Hex head cap						4	AB
-4	*	.	Screw - Hex head cap						4	CD
-5	3441	.	Washer						4	AB
-5	*	.	Washer						4	CD
-6	3478	.	Nut						4	AB
-6	*	.	Nut						4	CD
-7	603979	.	Screw - Hex head cap						4	AB
-7	225851	.	Screw - Hex head cap						2	CD
-8	212211	.	Screw - Hex head cap						2	CD
-9	3236	.	Screw - Hex socket dog point set						1	AB
-9	3238	.	Screw - Hex socket dog point set						1	CD
-10	603964	.	Plate - Motor						1	AB
-10	603965	.	Plate - Motor						1	CD
-11	604691	.	Shaft - Motor plate						1	AB
-11	604250	.	Shaft - Motor plate						1	CD
-12	3814	.	Collar						1	AB
-12	3826	.	Collar						1	CD
-13	1890	.	Pin - Taper						1	All

* Specify type of motor and frame used.

Figure and Index No.	Part No.	Nomenclature							Units Per Assy	Application Code
		1	2	3	4	5	6	7		
COOLANT SYSTEM AND PAN (SEE FIGURE 23)										
23-1	605315	.	Pan						1	A
-1	605316	.	Pan						1	B
-1	605317	.	Pan (without center leg)						1	C
-1	605319	.	Pan (with center leg)						1	C
-1	605332	.	Pan (without center leg)						1	D
-1	605320	.	Pan (with center leg)						1	D
Attaching Parts										
-2	3215	.	Screw - Socket head cap						2	All
-3	3442	.	Washer						2	All
-4	603385	.	Stud						2	All
----- *										
-5	605322	.	Cover - Dry Pan						1	All
-6	605325	.	Gasket						1	All
Attaching Parts										
-7	2369	.	Screw						8	All
-8	3472	.	Nut						8	All
----- *										
-9	605323	.	Sieve						1	All
-10	605321	.	Tank - Coolant						1	All
-11	220784	.	Plug						1	All
-12	605236	.	Gasket - Pump						1	All
-13		.	Pump - Coolant - Electrical characteristics as specified							
Attaching Parts										
-14	3403	.	Screw						4	All
-15	605247	.	Strap - Support						1	All
-16	2374	.	Screw						1	All
-17	3473	.	Nut						1	All

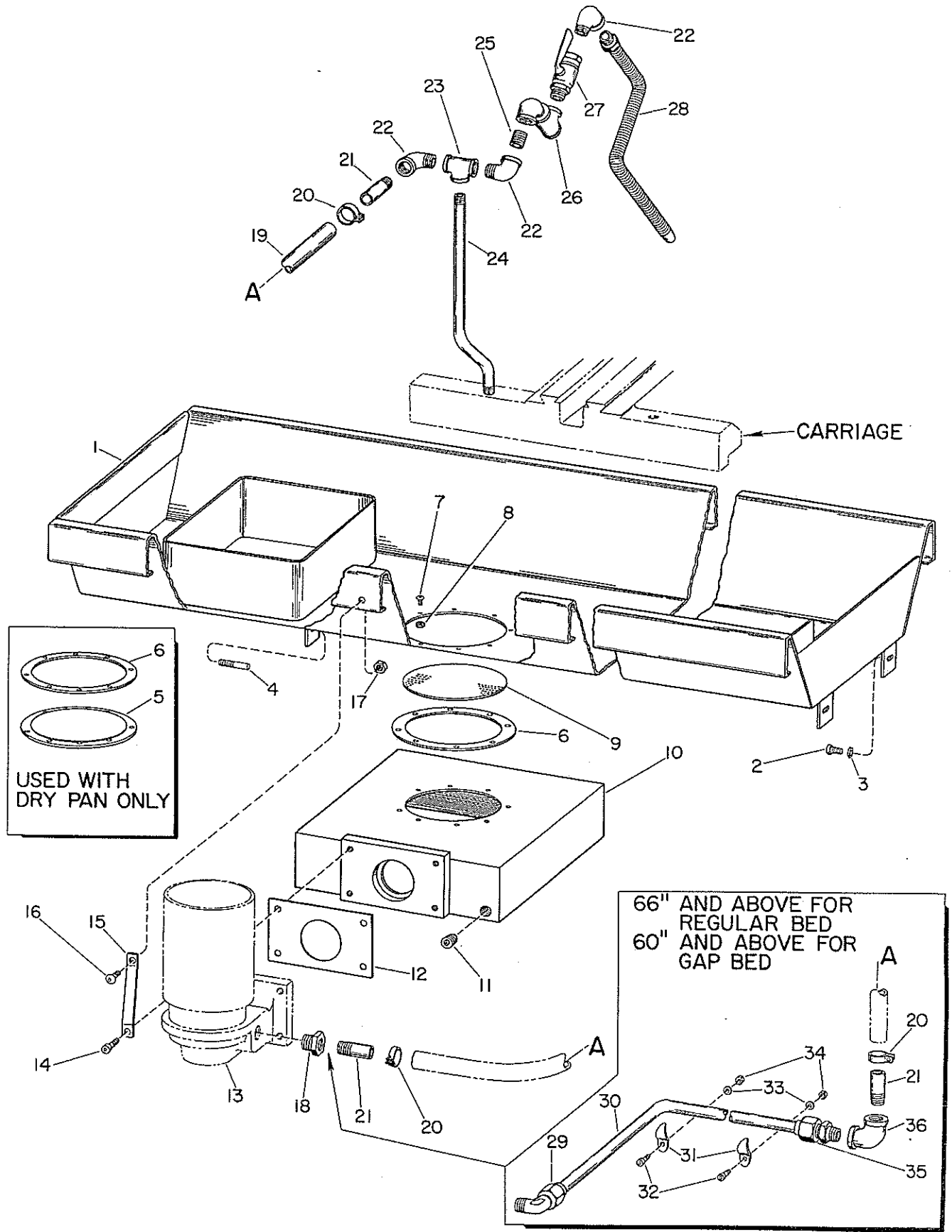

Figure 23. Coolant System and Pan

Figure and Index No.	Part No.	1	2	3	4	5	6	7	Nomenclature	Units Per Assy	Application Code
COOLANT SYSTEM AND PAN (SEE FIGURE 23) (CONT'D)											
----- *											
-18	59799	.							Bushing (for Pioneer Model UBA 125 or Ruthman Model 1C)	1	All
-18	213032	.							Bushing (for Ruthman Model DOC-5 or Pioneer Models VBA 10F or VBA 25F)	1	All
-19	605069	.							Hose	1	All
-20	98607	.							Clamp - Hose	2	All
-21	603183	.							Pipe	2	All
-22	29810	.							Elbow	3	All
-23	89870	.							Tee	1	All
-24	604663	.							Rod - Support	1	AB
-24	603170	.							Rod - Support	1	CD
-25	10051	.							Nipple	1	All
-26	603173	.							Joint - Swing	1	All
-27	600097	.							Cock - Lever	1	All
-28	97943	.							Nozzle	1	All
----- *											
For 15" & 18" Models above 66" regular bed and 60" Gap bed											
-29	130962	.							Elbow	1	CD
-30	605329	.							Tubing - 60" thru 84" reg. and gap bed	1	CD
-30	605330	.							Tubing - 90" thru 102" reg. and gap bed	1	CD
-30	605331	.							Tubing - 108" thru 114" reg. and gap bed	1	CD
-31	3990	.							Clamp - Tubing	2	CD
-32	3203	.							Screw	2	CD
-33	217968	.							Washer	2	CD
-34	3472	.							Nut	2	CD
-35	130961	.							Connector	1	CD
-36	24024	.							Elbow	1	CD

Figure and Index No.	Part No.	1	2	3	4	5	6	7	Nomenclature	Units Per Assy	Application Code
STANDARD AND SPECIAL EQUIPMENT (SEE FIGURE 24)											
24-									Chasing Dial		
24-1	600327	.							Dial	1	All
									Attaching Parts		
-2	3203	.							Screw - Low socket head cap	1	All
----- *											
-3	202831	.							Nut - Knurled	1	All
-4	3442	.							Washer	1	All
-5	604681	.							Bracket - Chasing dial	1	AB
-5	604306	.							Bracket - Chasing dial, regular	1	CD
-5	604447	.							Bracket - Chasing dial, gap	1	CD
-6	604308	.							Stud - Chasing dial, regular	1	All
-6	604448	.							Stud - Chasing dial, gap	1	CD
-7	604682	.							Shaft - Chasing dial	1	AB
-7	604307	.							Shaft - Chasing dial	1	CD
-8	600657	.							Worm - Wheel	1	AB
-8	600607	.							Worm - Wheel	1	CD
									Attaching Parts		
-9	2291	.							Pin - Taper	1	All

Figure and Index No.	Part No.	Nomenclature	Units Per Assy	Application Code
STANDARD AND SPECIAL EQUIPMENT (SEE FIGURE 24) (CONT'D)				
24-10	605002	. Plate - Instruction	1	All
		Attaching Parts		
-11	3178	. Screw - Drive	4	All
24-		Micrometer Carriage Stop	1	AB
-12	604689	. Clamp - Carriage stop	1	CD
-12	604294	. Clamp - Carriage stop		
		Attaching Parts		
-13	604690	. Screw - Carriage stop	1	AB
-13	603433	. Screw - Carriage stop	1	CD
-13A	604951	. Button - Carriage	2	All
----- * -----				
-14	601040	. Nut - Locking	1	All
-15	3230	. Screw - Hex socket dog point set	1	All
-16	2354	. Screw - Hex socket lock	2	All
-17	2048-T	. Screw - Headless cone point set	1	All
-18	601038	. Screw - Adjusting	1	All
-19	601039	. Dial - Micrometer, American	1	All
-19	601346	. Dial - Micrometer, Metric	1	All
-20	604688	. Body - Carriage stop	1	AB
-20	604103	. Body - Carriage stop	1	CD
24-		Single Automatic Length Stop		
-21	4190	. Nut - Lock	1	AB
-21	4191	. Nut - Lock	1	CD
-22	601349	. Lever - Trip	1	AB
-22	601347	. Lever - Trip	1	CD
-23	601350	. Bushing - Trip lever	1	AB
-23	601348	. Bushing - Trip lever	1	CD
		Attaching Parts		
-24	1890	. Pin - Taper	1	All
----- * -----				
-25	601084	. Stop - Length	1	AB
-25	604235	. Stop - Length	1	CD
-26	2260	. Screw - Hex head cap	1	AB
-26	3428	. Screw - Hex head cap	1	CD
24-		Compound Connected Rest		
-27	604563	. Slide - Cross	1	A
-27	604564	. Slide - Cross	1	B
-27	604012	. Slide - Cross	1	C
-27	604013	. Slide - Cross	1	D
-28	602488	. Gib - Cross slide	1	AB
-28	602844	. Gib - Cross slide	1	C
-28	602849	. Gib - Cross slide	1	D
-28A	3383	. Pin - Straight	1	All
		Attaching Parts		
-29	604536	. Screw - Gib	2	AB
-29	604372	. Screw - Gib	2	CD
----- * -----				
-30	604565	. Base - Tool post	1	A
-30	604566	. Base - Tool post	1	B
-30	604162	. Base - Tool post	1	C
-30	602848	. Base - Tool post	1	D
		Attaching Parts		
-31	3473	. Nut - Hex	4	A
-31	3478	. Nut - Hex	4	B
-31	3479	. Nut - Hex	4	CD
-32	3441	. Washer	4	AB
-32	3442	. Washer	4	CD
-33	3314	. Bolt - Tee	4	A
-33	3328	. Bolt - Tee	4	B
-33	3274	. Bolt - Tee	4	CD
----- * -----				
24-		Follow Rest		
-34	604651	. Rest - Follow	1	A

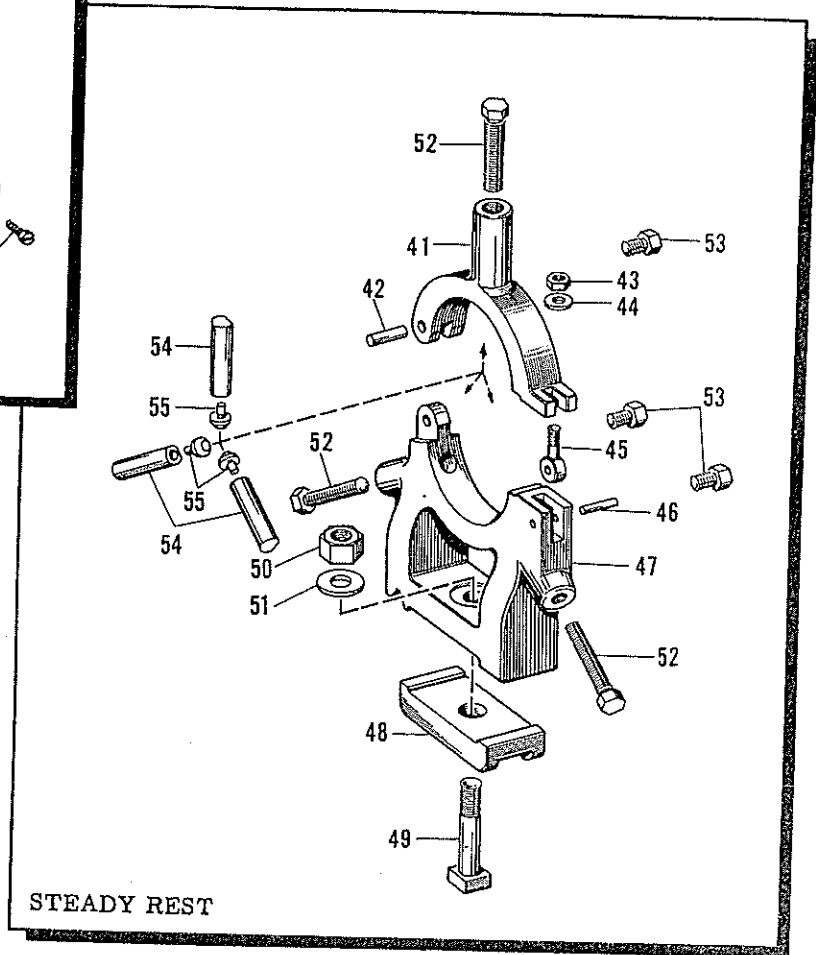
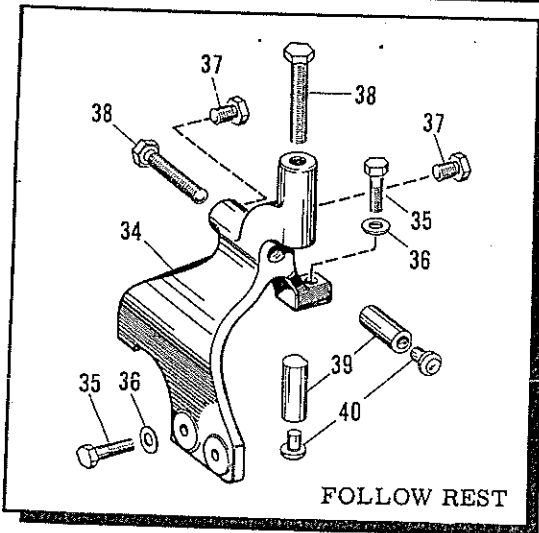
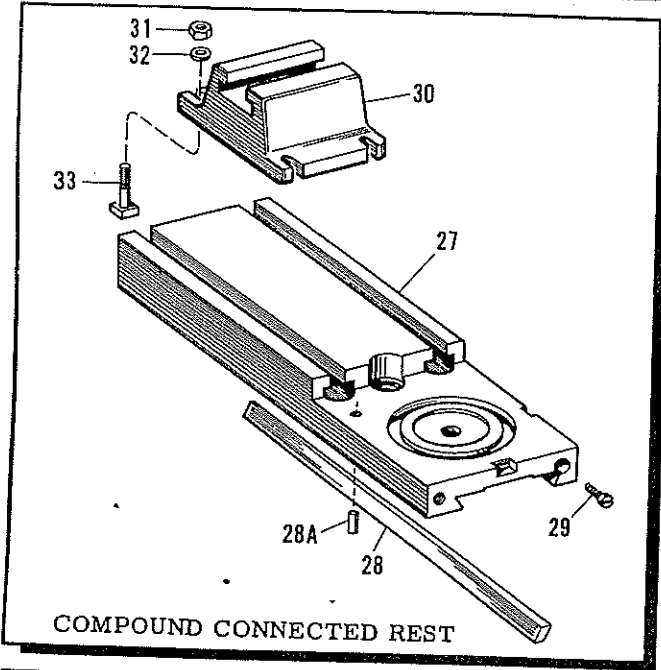
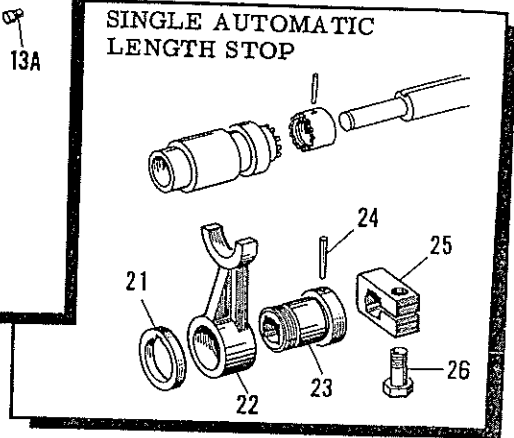
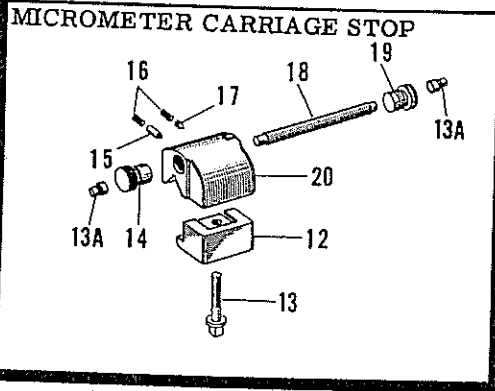
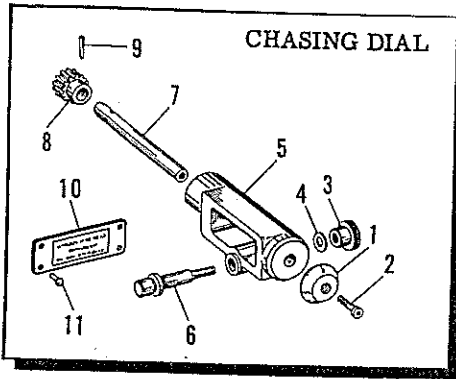

Figure 24. Standard and Special Equipment

Figure and Index No.	Part No.	1 2 3 4 5 6 7	Nomenclature	Units Per Assy	Application Code
STANDARD AND SPECIAL EQUIPMENT (SEE FIGURE 24) (CONT'D)					
24-34	604652		. Rest - Follow	1	B
-34	604006		. Rest - Follow	1	C
-34	604005		. Rest - Follow	1	D
Attaching Parts					
-35	3463		. Screw - Hex head cap	3	All
-36	3442		. Washer	3	All
- - - - - * - - - - -					
-37	2154		. Screw - Hex head	2	AB
-37	600022		. Screw - Hex head	2	CD
-38	217928		. Screw - Hex head cap	2	AB
-38	600269		. Screw - Hex head cap	2	CD
-39	600718		. Jaw	2	AB
-39	600268		. Jaw	2	CD
-40	605028		. Tip - Jaw	2	All
24-			Steady Rest		
-41	600714		. Top - Steady rest, regular capacity	1	AB
-41	601307		. Top - Steady rest, special capacity	1	AB
-41	605031		. Top - Steady rest, regular capacity	1	CD
-41	600791		. Top - Steady rest, special capacity	1	CD
Attaching Parts					
-42	244625		. Pin - Straight	1	All
-42	66535		. Pin - Straight	1	All
- - - - - * - - - - -					
-43	3478		. Nut - Hex	1	AB
-43	76639		. Nut - Hex	1	CD
-44	3441		. Washer	1	AB
-44	3442		. Washer	1	CD
-45	600716		. Bolt - Eye	1	AB
-45	600019		. Bolt - Eye	1	CD
Attaching Parts					
-46	1384		. Pin - Straight	1	All
- - - - - * - - - - -					
-47	604670		. Bottom - Steady rest, regular capacity	1	A
-47	604671		. Bottom - Steady rest, special capacity	1	A
-47	604678		. Bottom - Steady rest, regular capacity	1	B
-47	604679		. Bottom - Steady rest, special capacity	1	B
-47	605029		. Bottom - Steady rest, regular capacity	1	C
-47	604108		. Bottom - Steady rest, special capacity	1	C
-47	605030		. Bottom - Steady rest, regular capacity	1	D
-47	604140		. Bottom - Steady rest, special capacity	1	D
-48	600722		. Clamp	1	A
-48	600725		. Clamp	1	B
-48	600024		. Clamp	1	C
-48	604141		. Clamp	1	D
Attaching Parts					
-49	3286		. Bolt - Tee	1	A
-49	600726		. Bolt - Tee	1	B
-49	3286		. Bolt - Tee (special capacity)	1	B
-49	2232		. Bolt - Tee	1	CD
-49	2232		. Bolt - Tee (special capacity)	1	C
-50	3480		. Nut - Hex	1	AB
-50	3475		. Nut - Hex (special capacity)	1	AB
-50	3481		. Nut - Hex	1	CD
-51	1040		. Washer	1	AB
-51	764		. Washer	1	CD
- - - - - * - - - - -					
-52	600719		. Screw - Hex head	3	AB
-52	600023		. Screw - Hex head	3	CD
-53	2154		. Screw - Hex head	3	AB
-53	600022		. Screw - Hex head	3	CD
-54	600717		. Jaw	3	AB
-54	605026		. Jaw	3	CD
-54	600268		. Jaw (special capacity)	3	CD
-55	605028		. Tip - Jaw	3	All

Figure and Index No.	Part No.	1 2 3 4 5 6 7	Nomenclature	Units Per Assy	Application Code
ACCESSORY EQUIPMENT (SEE FIGURE 25)					
25- 25-1	604007		Four Position Cross Feed Stop . Support - Front	1	All
			Attaching Parts		
-2	2320		. Screw - Socket head cap	1	All
-3	2322		. Screw - Socket head cap	1	All
-4	14556		. Pin - Square head taper	2	All
			-----*		
-5	1917		. Screw - Hollow set	1	All
-6	601683		. Spring - Compression	1	All
-7	13665		. Ball - Steel	1	All
-8	206084		. Knob - Knurled	1	All
			Attaching Parts		
-9	141		. Pin - Taper	1	All
			-----*		
-10	94753		. Collar	1	All
			Attaching Parts		
-11	141		. Pin - Taper	1	All
			-----*		
-12	604654		. Shaft - Cross feed stop	1	A
-12	604655		. Shaft - Cross feed stop	1	B
-12	604009		. Shaft - Cross feed stop	1	C
-12	604010		. Shaft - Cross feed stop	1	D
-13	601856		. Rotor - Cross feed stop	1	All
			Attaching Parts		
-14	143		. Pin - Taper	1	All
			-----*		
-15	601798		. Screw - Stop	4	A
-15	601804		. Screw - Stop	4	B
-15	601821		. Screw - Stop	4	C
-15	604011		. Screw - Stop	4	D
-16	96271		. Nut - Knurled lock	4	A
-16	601788		. Nut - Knurled lock	4	BCD
-17	604653		. Support - Rear	1	All
			Attaching Parts		
-18	3396		. Screw - Socket head cap	1	All
-19	3397		. Screw - Socket head cap	1	All
			-----*		
-20	601859		. Stop - Plug	2	All
			Attaching Parts		
-21	2320		. Screw - Socket head cap	2	All
			-----*		
-22	604683		. Slide - Cross, alteration	1	A
-22	604701		. Slide - Cross, alteration	1	B
-22	603587		. Slide - Cross, alteration	1	CD
25-			Four Position Carriage Stop		
-23	604710		. Housing - Carriage stop	1	AB
-23	604433		. Housing - Carriage stop	1	CD
-24	601786		. Rotor	1	All
-25	601789		. Plate - Rotor	1	All
			Attaching Parts		
-26	3266		. Screw - Socket head cap	1	All
			-----*		
-27	601785		. Screw - Stop	4	All
-28	601788		. Nut - Lock, knurled	4	All
-29	604709		. Plate - Clamp	1	AB
-29	604950		. Plate - Clamp	1	CD
			Attaching Parts		
-30	3168		. Screw - Hex head cap	1	All
			-----*		
-31	3543		. Pin - Straight	1	AB
-31	230058		. Pin - Straight	1	CD
-32	1911		. Screw - Hex socket flat point set	1	All

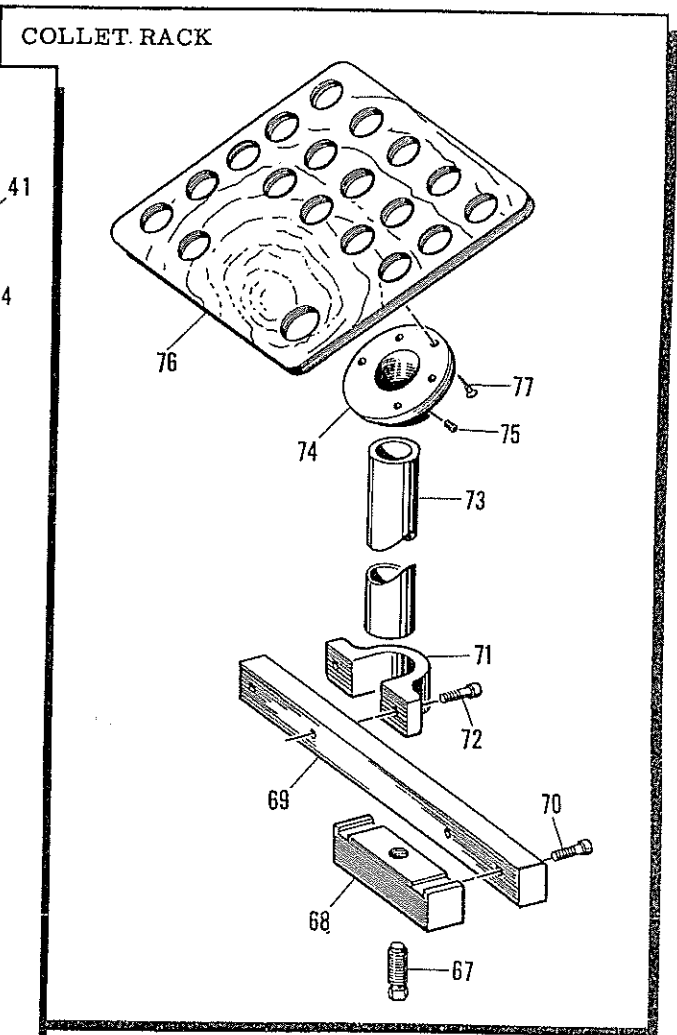
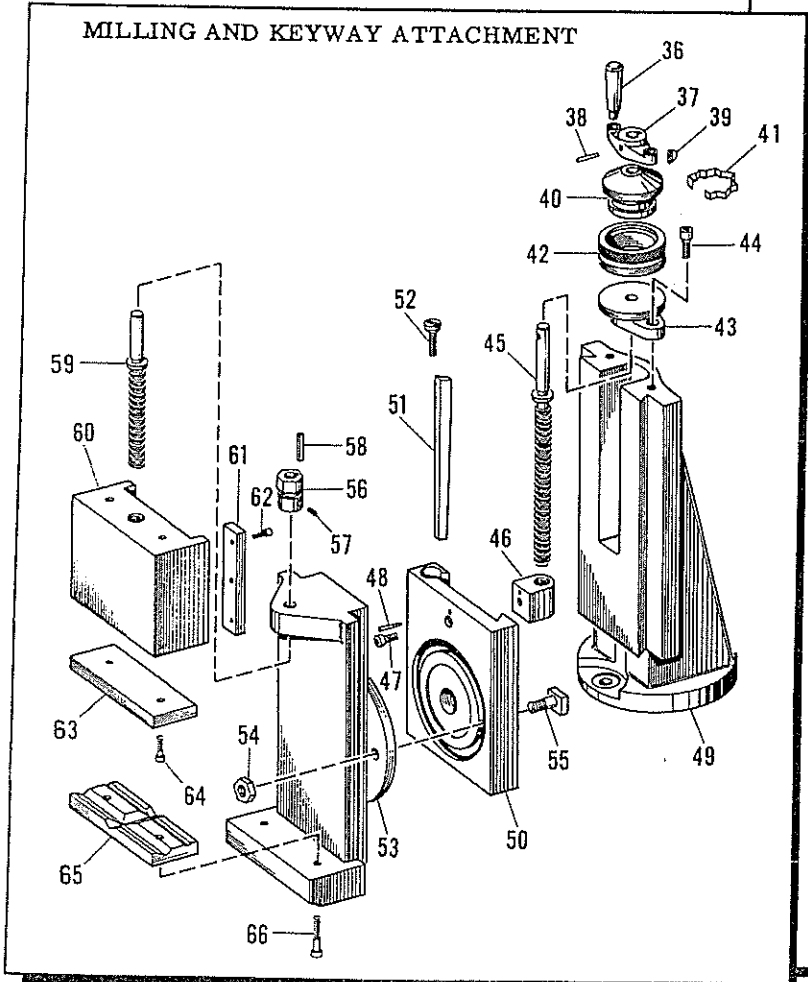
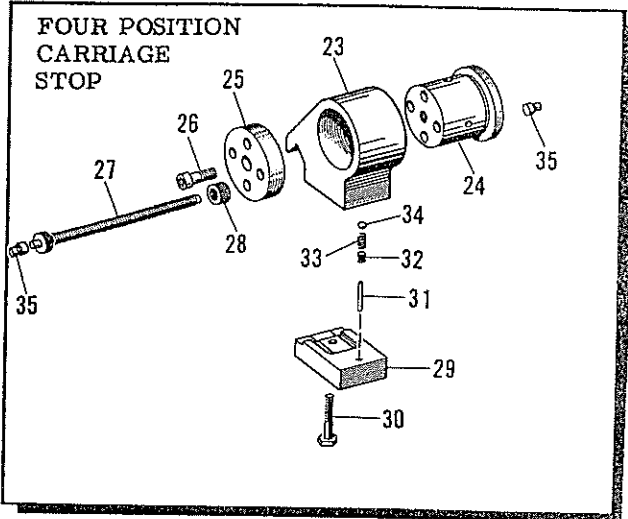
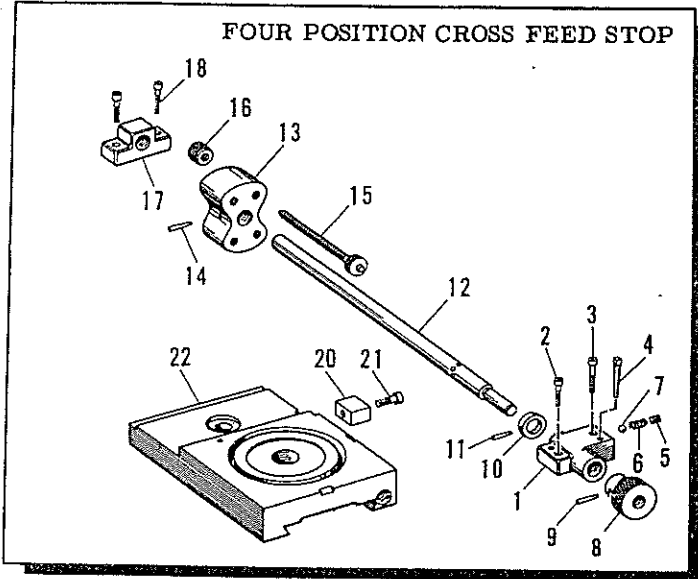

Figure 25. Accessory Equipment

Figure and Index No.	Part No.	1	2	3	4	5	6	7	Nomenclature	Units Per Assy	Application Code
ACCESSORY EQUIPMENT (SEE FIGURE 25) (CONT'D)											
25-33	601683	.							Spring - Detent	1	All
-34	13665	.							Ball - Steel	1	All
-35	604951	.							Button - Carriage	2	All
25-									Milling and Keyway Attachment		
-36	604164	.							Handle	2	All
-37	604541	.							Handle - Top slide	1	AB
-37	603380	.							Handle - Top slide	1	CD
									Attaching Parts		
-38	2291	.							Pin - Taper	1	AB
-38	141	.							Pin - Taper	1	CD
									* - - - - -		
-39	1266	.							Key - Woodruff	1	All
-40	604538	.							Bushing - Dial	1	AB
-40	600313	.							Bushing - Dial	1	CD
-41	600545	.							Spring - Dial	1	AB
-41	600288	.							Spring - Dial	1	CD
-42	600587	.							Dial - Top slide, American	1	AB
-42	600590	.							Dial - Top slide, Metric	1	AB
-42	600320	.							Dial - Top slide, American	1	CD
-42	600323	.							Dial - Top slide, Metric	1	CD
-43	601770	.							Bushing	1	AB
-43	601744	.							Bushing	1	CD
									Attaching Parts		
-44	3218	.							Screw - Socket head cap	2	AB
-44	3399	.							Screw - Socket head cap	2	CD
									* - - - - -		
-45	601772	.							Screw - Vertical feed, American	1	AB
-45	601773	.							Screw - Vertical feed, Metric	1	AB
-45	601747	.							Screw - Vertical feed, American	1	CD
-45	601748	.							Screw - Vertical feed, Metric	1	CD
-46	600585	.							Nut - Top slide, American	1	AB
-46	600588	.							Nut - Top slide, Metric	1	AB
-46	604514	.							Nut - Top slide, American	1	CD
-46	604515	.							Nut - Top slide, Metric	1	CD
									Attaching Parts		
-47	3218	.							Screw - Socket head cap	1	AB
-47	3399	.							Screw - Socket head cap	1	CD
-48	140	.							Pin - Taper	1	AB
-48	141	.							Pin - Taper	1	CD
									* - - - - -		
-49	604857	.							Bracket - Swivel	1	A
-49	604863	.							Bracket - Swivel	1	B
-49	604860	.							Bracket - Swivel	1	C
-49	604861	.							Bracket - Swivel	1	D
-50	604865	.							Slide - Vertical	1	AB
-50	604864	.							Slide - Vertical	1	CD
-51	600942	.							Gib - Vertical slide	1	AB
-51	600891	.							Gib - Vertical slide	1	CD
									Attaching Parts		
-52	604536	.							Screw - Gib	2	AB
-52	604372	.							Screw - Gib	2	CD
									* - - - - -		
-53	601761	.							Body - Vise swivel	1	AB
-53	601751	.							Body - Vise swivel	1	CD
									Attaching Parts		
-54	3473	.							Nut - Hex	2	AB
-54	3474	.							Nut - Hex	2	CD
-55	601469	.							Bolt - Swivel	2	AB
-55	600274	.							Bolt - Swivel	2	CD
									* - - - - -		
-56	601767	.							Nut - Vise clamp screw	1	AB

Figure and Index No.	Part No.	1	2	3	4	5	6	7	Nomenclature	Units Per Assy	Application Code	
ACCESSORY EQUIPMENT (SEE FIGURE 25) (CONT'D)												
25-56	601757								. Nut - Vise clamp screw	1	CD	
		Attaching Parts										
-57	2332								. Screw - Hex socket set	1	All	
		- - - - - * - - - - -										
-58	864								. Key	1	All	
-59	601766								. Screw - Vise clamp	1	AB	
-59	601756								. Screw - Vise clamp	1	CD	
-60	601762								. Slide - Vise clamp	1	AB	
-60	601752								. Slide - Vise clamp	1	CD	
-61	601763								. Plate - Vise clamp	2	AB	
-61	601753								. Plate - Vise clamp	2	CD	
		Attaching Parts										
-62	3218								. Screw - Socket head cap	4	AB	
-62	3218								. Screw - Socket head cap	6	CD	
		- - - - - * - - - - -										
-63	601764								. Jaw - Vise, upper	1	AB	
-63	601754								. Jaw - Vise, upper	1	CD	
		Attaching Parts										
-64	3396								. Screw - Socket head cap	2	All	
		- - - - - * - - - - -										
-65	601765								. Jaw - Vise, lower	1	AB	
-65	601755								. Jaw - Vise, lower	1	CD	
		Attaching Parts										
-66	3227								. Screw - Socket head cap	2	AB	
-66	3217								. Screw - Socket head cap	2	CD	
		- - - - - * - - - - -										
25-		Collet Rack										
-67	1874-T								. Screw - Hex head dog point	1	AB	
-67	676-T								. Screw - Hex head dog point	1	CD	
-68	601807								. Clamp - Collet rack bracket	1	A	
-68	601808								. Clamp - Collet rack bracket	1	B	
-68	601809								. Clamp - Collet rack bracket	1	C	
-68	604218								. Clamp - Collet rack bracket	1	D	
-69	604310								. Bracket - Support	1	AB	
-69	604219								. Bracket - Support	1	CD	
		Attaching Parts										
-70	3399								. Screw - Socket head cap	2	AB	
-70	3266								. Screw - Socket head cap	2	CD	
		- - - - - * - - - - -										
-71	601812								. Bracket - Tube	1	AB	
-71	604843								. Bracket - Tube	1	CD	
		Attaching Parts										
-72	3266								. Screw - Socket head cap	2	All	
		- - - - - * - - - - -										
-73	601813								. Tube - Collet rack support	1	AB	
-73	604845								. Tube - Collet rack support	1	CD	
-74	601814								. Bracket - Board	1	AB	
-74	604844								. Bracket - Board	1	CD	
		Attaching Parts										
-75	1911								. Screw - Hex head flat point	1	All	
		- - - - - * - - - - -										
-76	604848								. Board - Collet rack (# 1-AM)	1	A	
-76	601815								. Board - Collet rack (# 1-J)	1	A	
-76	601818								. Board - Collet rack (# 6-H)	1	ABC	
-76	601816								. Board - Collet rack (# 2-J)	1	CD	
-76	604850								. Board - Collet rack (# 3-J)	1	CD	
-76	604849								. Board - Collet rack (# 2-J)	1	All	
-76	604855								. Board - Rubber flex collet	1	All	
		Attaching Parts										
-77	Coml								. Screw - Wood #8	5	All	

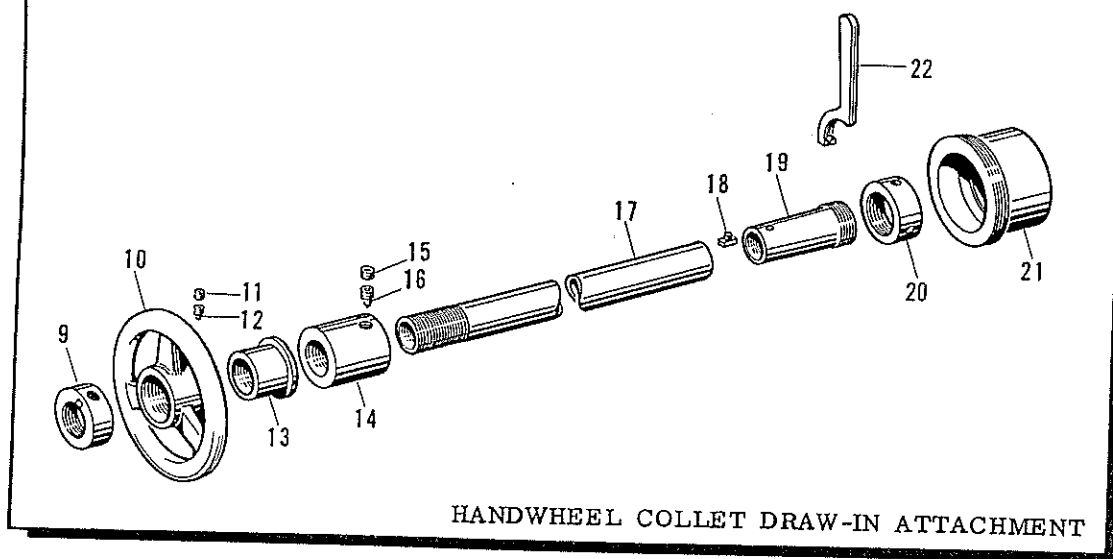
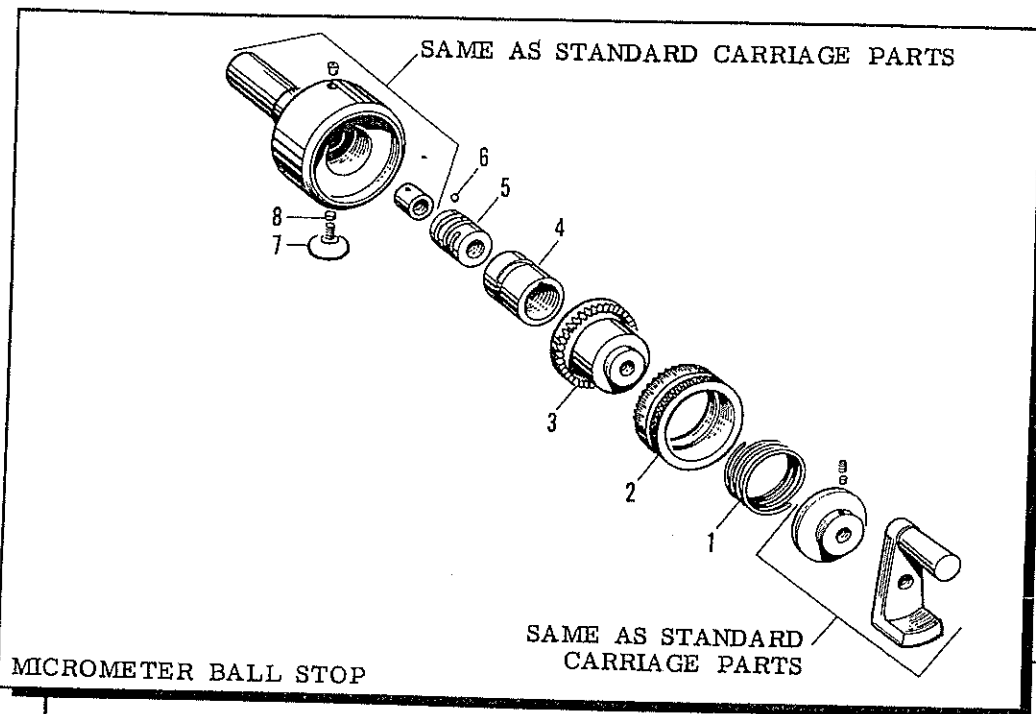

Figure 26. Accessory Equipment

Figure and Index No.	Part No.	1	2	3	4	5	6	7	Nomenclature	Units Per Assy	Application Code
ACCESSORY EQUIPMENT (SEE FIGURE 26)											
26-									Micrometer Ball Stop		
26-1	602675								. Spring - Compression	1	AB
-1	602663								. Spring - Compression	1	CD
-2	602669								. Dial - Cross feed, American	1	AB
-2	602670								. Dial - Cross feed, Metric	1	AB
-2	602659								. Dial - Cross feed, American	1	CD
-2	602660								. Dial - Cross feed, Metric	1	CD
-3	604583								. Clutch - Dial, cross feed, American	1	AB
-3	604584								. Clutch - Dial, cross feed, Metric	1	AB

Figure and Index No.	Part No.	1	2	3	4	5	6	7	Nomenclature	Units Per Assy	Application Code
ACCESSORY EQUIPMENT (SEE FIGURE 26) (CONT'D)											
26-3	602661	.							Clutch - Dial, cross feed	1	CD
-4	604556	.							Retainer - Ball	1	AB
-4	602668	.							Retainer - Ball	1	CD
-5	604581	.							Stop - Ball	1	AB
-5	602059	.							Stop - Ball	1	CD
-6	2290	.							Ball - Steel	1	AB
-6	30060	.							Ball - Steel	1	CD
-7	62	.							Screw - Thumb	1	AB
-7	59	.							Screw - Thumb	1	CD
-8	2008	.							Plug	1	AB
-8	605099	.							Plug	1	CD
26-									Collet Draw - In Attachment		
-9	4245	.							Nut - Lock (L00 Spindle)	1	A
-9	4247	.							Nut - Lock (L0 Spindle)	1	ABC
-9	4249	.							Nut - Lock (L1 Spindle)	1	CD
-10	604176	.							Handwheel	1	All
									Attaching Parts		
-11	2353	.							Screw - Low socket set	1	All
-12	103323	.							Screw - Hex socket dog point set	1	All
									- - - - - * - - - - -		
-13	604169	.							Bushing - Threaded (L00 Spindle)	1	A
-13	604822	.							Bushing - Threaded (L0 Spindle)	1	ABC
-13	604823	.							Bushing - Threaded (L1 Spindle)	1	CD
-14	604821	.							Sleeve - Thrust (L00 Spindle)	1	A
-14	604820	.							Sleeve - Thrust (L0 Spindle)	1	AB
-14	604168	.							Sleeve - Thrust (L0 Spindle)	1	C
-14	604171	.							Sleeve - Thrust (L1 Spindle)	1	CD
									Attaching Parts		
-15	2354	.							Screw - Hollow hex lock	1	AB
-15	2356	.							Screw - Hollow hex lock	1	CD
-16	103128	.							Screw - Hex head dog point set	1	AB
-16	105147	.							Screw - Hex head dog point set	1	CD
									- - - - - * - - - - -		
-17	604825	.							Sleeve - L00 Spindle	1	A
-17	604824	.							Sleeve - L0 Spindle	1	AB
-17	604170	.							Sleeve - L0 Spindle	1	C
-17	604175	.							Sleeve - L1 Spindle	1	CD
-18	109203	.							Key - Sleeve, draw in collet	1	All
-19	601970	.							Adapter - Collet (L00 Spindle)	1	A
-19	601720	.							Adapter - Collet (L0 Spindle)	1	ABC
-19	604173	.							Adapter - Collet (L1 Spindle)	1	CD
-20	601715	.							Nut - Adapter draw out (L00 Spindle)	1	A
-20	601723	.							Nut - Adapter draw out (L0 Spindle)	1	ABC
-20	604172	.							Nut - Adapter draw out (L1 Spindle)	1	CD
-21	601713	.							Guard - Spindle nose (L00 Spindle)	1	A
-21	601721	.							Guard - Spindle nose (L0 Spindle)	1	ABC
-21	604174	.							Guard - Spindle nose (L1 Spindle)	1	CD
-22	601924	.							Wrench - Pin, spanner (L00 Spindle)	1	A
-22	601923	.							Wrench - Pin, spanner (L0 Spindle)	1	ABC
-22	603906	.							Wrench - Pin, spanner (L1 Spindle)	1	CD