

Boley

In the micron range

517

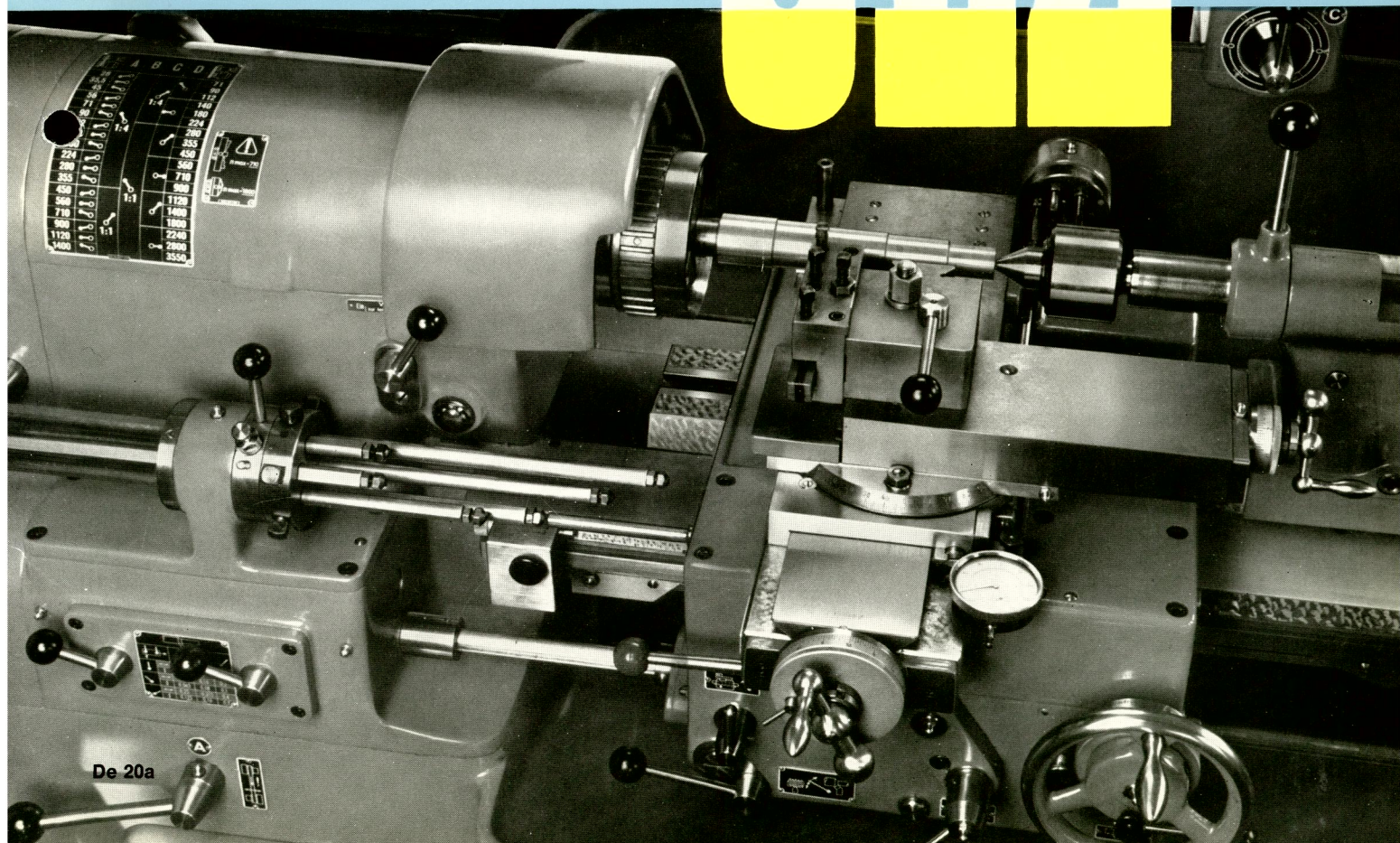

De 20a

Sliding, Surfacing and Screw Cutting Lathe

Outstanding Features

Consistently maintained accuracy – even with heavy cuts

A wide spindle speed range: 22 speeds from 28 to 3550 r.p.m., with uniform close play maintained in bearings

Stop turning against a six-station longitudinal stop and a six-station facing stop – high releasing accuracy by a drop worm.

All operating controls within easy reach. The machine is exceptionally practical

Short times for tool and component change

High cutting capacity using the hydraulic profiling attachment

Handling times for controlling and indexing considerably reduced

9 longitudinal feeds from .063 to .4 mm. (.0025 to .016") per rev., **9 facing feeds** from .032 to .2 mm. (.0013 to .008") per rev.; also fine feeds down to .01 mm. (.0004") per rev.

Leadscrew and feed spindle, i. e. pitches and feeds can be set independently of each other. Automatic drop-nut release

Rapid change-over from turning to screwcutting and vice versa

Directions of feed to saddle – right or left – **and to facing slide** – forwards or backwards – are also adjustable independently of each other

Large space for change-gears, so that unusual pitches can also be cut

Ample space for swarf. Longitudinal and facing stops out of reach of swarf

Semi-automatic screwcutting attachment with quadrupled return speed, resulting in considerable time saving

High frequency of reversals for screwcutting

Sturdily built saddle suitable for accommodating rear toolholders

Hardened saddle slideways – ensuring low rate of wear

Machine bed of special casting with long covered carriage slideways. This arrangement makes the slide-ways resistant to wear

The leadscrew arranged in the middle of the bed engages the slide at the focal point of resistance, ensuring smooth traversing

The machine is pleasing in appearance and is smooth, so that it is easy to clean and maintain

The 5 LZ is **so rigidly built** that tests undertaken by the Technical College in Aachen failed to make it chatter.

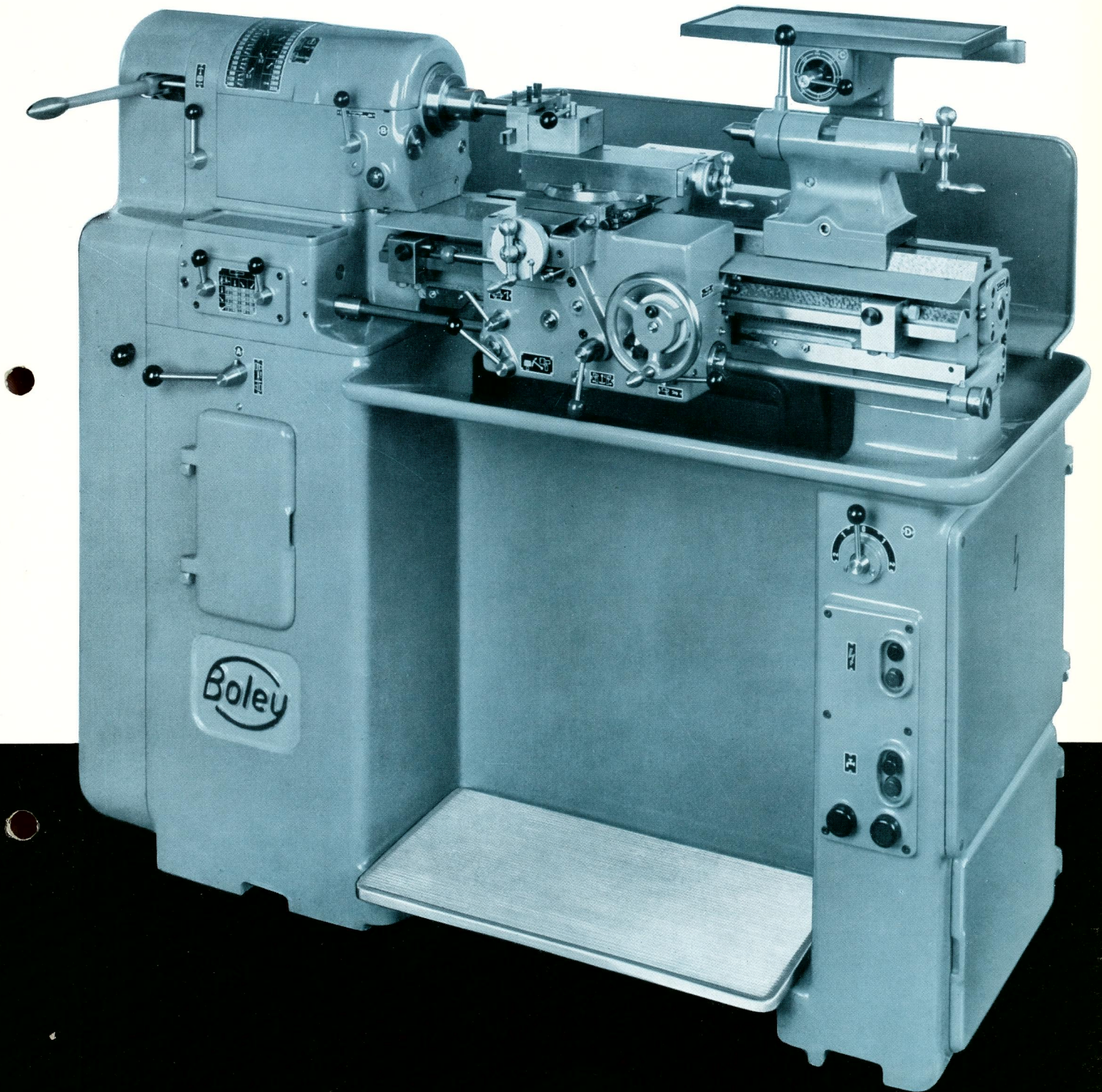

So handy — so conveniently arranged for the operator

The lathe for high demands

5 LZ

The BOLEY 5 LZ sliding, facing and screwcutting lathe, developed in accordance with the very latest working physiological knowledge, is an exceptionally useful machine. It attracts attention by its external appearance alone, its elegant lines, its exceptional stability and its impressive design. Whole decades of experience in building lathes have been incorporated in this model.

Especially when used as a production machine, the 5 LZ proves highly efficient, as it can utilise tungsten carbide tools to their full capacity. This is corroborated by the fact that it is used in the production lines of many of the leading German and foreign firms. Its versatility also makes it especially suitable for use in tool-rooms and research workshops.

Hundreds of satisfied customers at home and abroad testify to this. Amongst these, there are some who make very high demands, such as jig boring firms, firms engaged in precision mechanics and in the optical industry. The car industry, electrical engineering, laboratories and scientific experimental establishments, as, indeed, nearly all branches of industry where great turning accuracy and economic production are essential, are amongst the users of this machine.

Arrangement to German DIN Standards.
Acceptance conditions to DIN 8605 and BON 320/3 E.

Capacity data

		mm	ins.
Height of centres		130	5 ¹ / ₈
Maximum swing	over carriage	200	8
Maximum turning diameter	over bed	250	10
Maximum turning diameter	over carriage	200	8
Maximum turning diameter	over bottom slide	140	5 ¹ / ₂
Maximum length turned in one pass		500	20
Maximum length of thread cut	without autom. device	430	16
Maximum distance between centres		500	20
Maximum carriage traverse		500	20
Traverse of longitudinal slide		95	3 ³ / ₄
Traverse of facing slide		150	6

Spindle

Working height above floor		1150	46
Spindle nose suitable for collets a 12, size 4 (see page 6)			—
Spindle nose, on request, with external steep taper internal Morse taper			3 DIN 55 022 4
Spindle bore diameter		23	7 ⁷ / ₈
Front bearing: plain			GL
Rear bearing: plain			GL
Step bearing: roller			WL

Chucking Parts

Faceplate diameter		240	9 ¹ / ₂
Clamping capacity (clamped externally)		from 34 to 200	1 ³ / ₈ to 8
Chuck diameter, standard/maximum		110/137	4 ³ / ₈ to 5 ³ / ₈
Clamping capacity (clamped externally)		3 to 50	1 ¹ / ₈ to 2
Collet a 12, size 4			
Maximum diameter clamped	with through bores	16	5 ⁵ / ₈
	with blind bores	20	3 ³ / ₄
Steady			
Maximum capacity	fixed	60	2 ³ / ₈
	travelling	60	2 ³ / ₈
Toolholder			
Maximum tool cross section		16 × 16	5 ⁵ / ₈ × 5 ⁵ / ₈
Tailstock			
Inside taper of sleeve		Morse 3	
Longitudinal movement of sleeve		80	3 ¹ / ₈
Lateral adjustment	left-hand and right-hand	10	3 ³ / ₈

Spindle speeds as per DIN 804

Step $\varphi = 1.25$	22 steps	from 28 to 3550 r.p.m.
Countershaft in headstock, ratio		1:4
Gear box, ratio		1:4

6 | Floor Plan

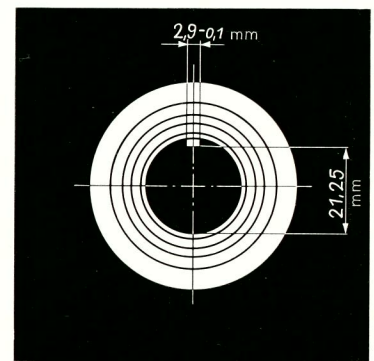
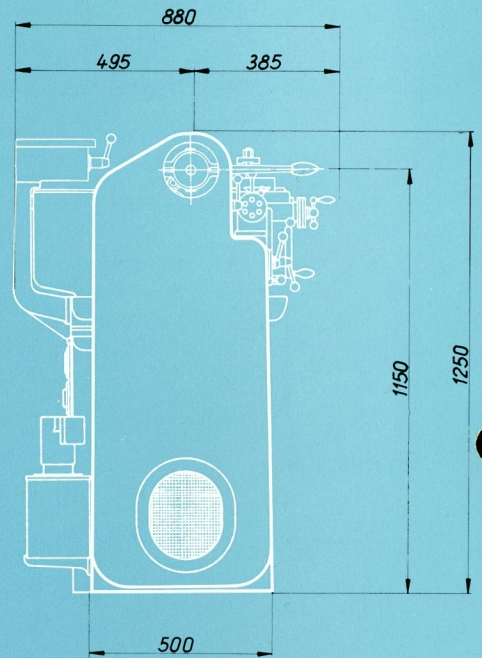
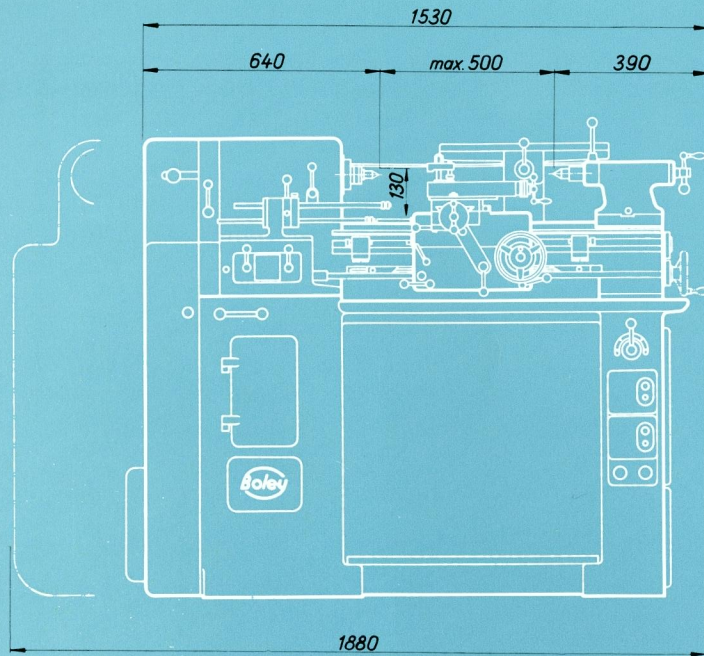

Top view of spindle nose
On request,
external steep taper 3 DIN 55022,
internal Morse taper No. 4

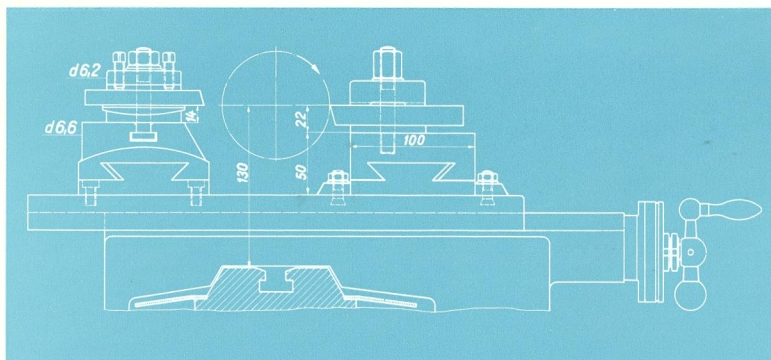

Working area over the saddle
(measurements in mm.)

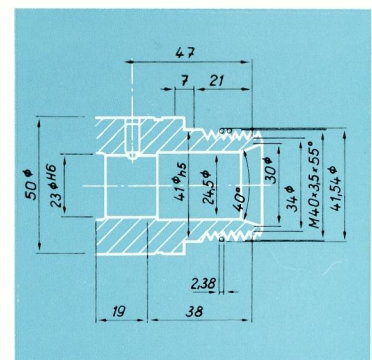

Longitudinal section through the spindle nose
(measurements in mm.)

Feeds as per DIN 803

			mm	ins.
Longitudinal	Step $\varphi = 1.25$	No. of steps 9	per rev. / .063 to .4	(.0025 – .016)*
Facing	Step $\varphi = 1.25$	No. of steps 9	per rev. / .032 to .2	(.0013 – .008)*
	Micro feeds for superfine turning		per rev. / .01 to .05	(.0004 – .002)
Finer feeds can be provided if required:				
Longitudinal	Step $\varphi = 1.25$	No. of steps 9	per rev. / .04/.25 or .022/.14	(.0016/.0098 or .00086/.055)
Facing	Step $\varphi = 1.25$	No. of steps 9	per rev. / .02/.125 or .011/.07	(.0008/.0049 or .00044/.0028)

* (Spindles of machine, normally with metric threads, are also available with inch threads)

Thread pitches

With change gears			
Metric threads	No. of threads 35		from .2 to, 24 mm
Inch threads	No. of threads 34		from 80 to 4 T.P.I.
Module threads	No. of threads 36		from .3 to 8 module
Leadscrew pitch to DIN 113			36 × 6 mm. Trapezoid

Drive

Drive capacity		1.3/2.2 kw.
Diving motor	Build to DIN 42950	Form B 5
	Casing to DIN 40050	P 33
	Speeds	750/1500 r.p.m.
	Arranged for	A.C., 3 phase
	Voltage (special voltages on request)	220 or 380 volts
	Frequency	50 cycles

Floor and space requirements

Basis space	length × width	1500 × 900 mm.	5 × 3 ft.
Height of machine		1250 mm.	4 ft.
Case dimensions		1.7 × 1.1 × 1.6 metres	5½ × 3½ × 5½ ft.
Shipping dimensions		approx. 3.0 cbm.	107 cu.ft.

Weights

Nett,	including electrical equipment	approx.	1000 KG = 1 ton
	without electrical equipment	approx.	950 KG = 19 cwt.
Gross,	packed for rail transport	approx.	1150 KG = 1 t. 3 cwt.
	packed for shipment	approx.	1200 KG = 1 t. 4 cwt.

Standard Equipment

included in the machine price

- 25 Pick-off gears with 25, 26, 27, 30, 30, 35, 40, 45, 50, 55, 60, 65 70, 75, 80, 85, 87, 90, 95, 100, 105, 110, 120, 125 and 127 teeth (for standard and odd pitches)
- 1 Driver plate a 48 m A
- 1 Centre adaptor a 24 with centre a 25
 - 1 Protecting nut for spindle thread
 - 1 Tungsten carbide tipped centre b 29,4 for tailstock
 - 1 Glass tube with 10 shear pins a Zt 1/54a
 - Tool kit, 2 Tins = 2 litres lubrication oil "Mobil Velocite Oil No. 4"
 - 1 Grease gun BON 417/1 for headstock
 - 1 Measuring device on lower slide
 - 1 Belt changing device
 - 1 Screw-operated tailstock b 5, with lateral adjustment
 - 2 Operating instructions

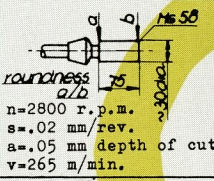
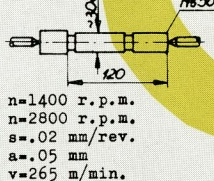
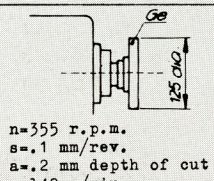
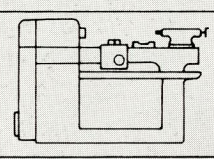
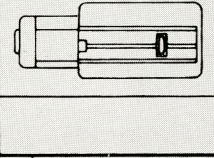
 Inspection procedure for BOLEY 5 LZ Sliding, Surfacing and Screwcutting Lathes. Acceptance directives for the working accuracy of the machine.		BON 320/3e Sheet 3		
The following measurements are required for use <u>within our own works</u> . Only extracts from these figures are entered in the Test Sheet BON 320/3e, Sheet 1, under Items 14-16, for the customer's use.				
Customer: Machine No. 60 635 NS 58 764 Date 30/11/61 Tester Dr.				
No.	Operation and measurements	Illustration	Permissible error mm	Actual error mm
1.	Turn bronze or brass pin without centres with diamond tool. Check <u>roundness</u> and <u>centricity</u> .	 <p> $n=2800$ r.p.m. $s=.02$ mm/rev. $a=.05$ mm depth of cut $v=265$ m/min. </p>	Roundness: at a: .005 at b: .005 Centricity: .005 in 75 mm	.002 .002 .002 in 75 mm
2.	Turn mild steel cylinder with diamond, radius 1 mm, held between centres. Check <u>finish</u> (roughness). Turn without using intermediate gears.	 <p> $n=1400$ r.p.m. $n=2800$ r.p.m. $s=.02$ mm/rev. $a=.05$ mm $v=265$ m/min. </p>	at 1400 r.p.m.: $R=.60$ μ m at 2800 r.p.m.: $R=.70$ μ m	$R=.28$ μ m $R=.45$ μ m
3.	Face driving plate, if included in Works Order. If not, face slave driving plate. Check flatness of face (only hollow).	 <p> $n=355$ r.p.m. $s=.1$ mm/rev. $a=.2$ mm depth of cut $v=140$ m/min. </p>	.015 in 120 mm	.01 in 120 mm
3a.	Bed straight longitudinally (convex only).		0 - .02 in 1000 mm	.01 in 1000 mm
3b.	Bed flat back to front. No distortion (\pm) permissible.		+ .02 or - .02 mm in 1000 mm	+ .01 in 1000 mm
4.	Release pressure max. 330 lbs.		Release pressure set to 330 lbs.	
Boley, Eblingen a.N.		Ersatz für Ersatz durch	Gez. 12. 1. 1967 <i>W. Gepr.</i> AV bearb. ges.	

Inspection card for turning test components at our works. All dimensions are in millimetres. Corresponding dimensions in inches: Roundness .00008" Centricity .00008" Surface finish: 2-4 micro-inches (at 1400 r.p.m.) 3-7 micro-inches (at 2800 r.p.m.)

Before any 5 LZ leaves our works, we must have a record of its working accuracy. The figures given by measurements made with the machine stationary and recorded in the inspection sheet are not sufficient for us. The actual running

accuracy figures are obtained by the methods shown alongside and the records are kept by the Works Management, so that the condition of the machine on delivery can be determined at any time.

When turning up to the six-station longitudinal stop d 31, the cut-out accuracy is .02 mm (about .0008").

Each machine is accompanied by an inspection card. Quite apart from the various inspections that take place in the course of making the machine, each machine is subjected to a general inspection after it is completed. Having carried out the inspection as outlined in the test book for machine tools (lathes with toolmakers' accuracy), the machine is used for turning test pieces, which reveal the working accuracy and the surface finish that can be achieved in turning and facing operations. The readings thus obtained are nearly always well within the permissible tolerances.

A well-known technical college carried out vibration tests on the machine on our behalf. Vibration forms and resonance curves were registered during dynamic tests with alternating stresses. Moreover, vibration measurements were taken during turning experiments, which included rough as well as fine turning. The report has confirmed that there are no visible chatter marks even during the heaviest load on the driving motor. The machine was stated to be **dynamically stable**.

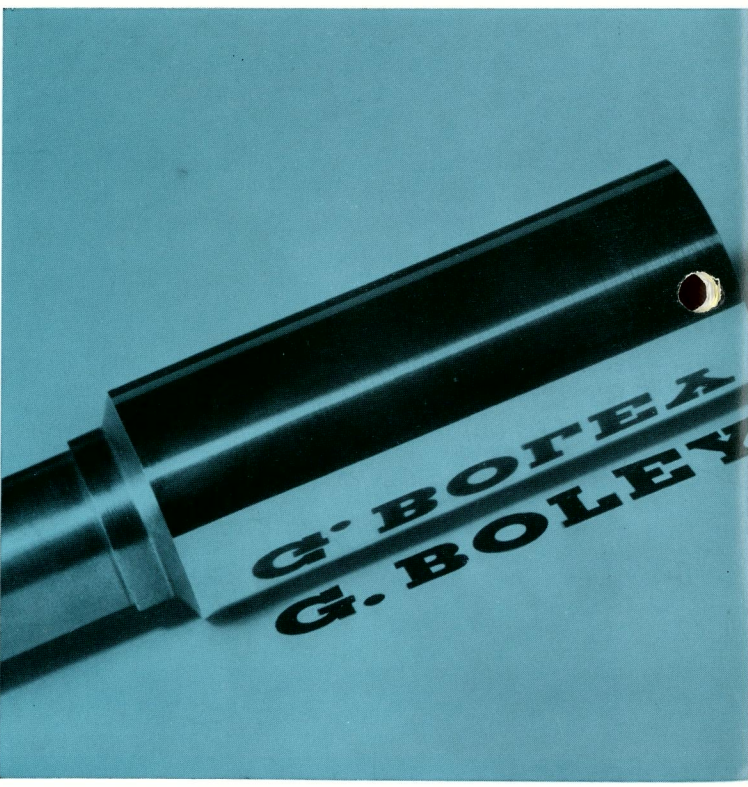

The sharp outlines of the mirror image give clear optical proof of the high finish of this test piece turned with a diamond tool.

This is a characteristic of BOLEY design, maintained throughout the years, combined with first-class workmanship.

The faces are turned to high accuracy and finished with minimum deviation from the geometric form. The excellent finish is achieved by a careful arrangement of bearings.

The diagram given below shows a surface finish curve of a test component, turned on a 5 LZ machine, selected at random (measurements taken on a Perth-O-Meter in our laboratory).

The measuring data are indicated in the diagram.

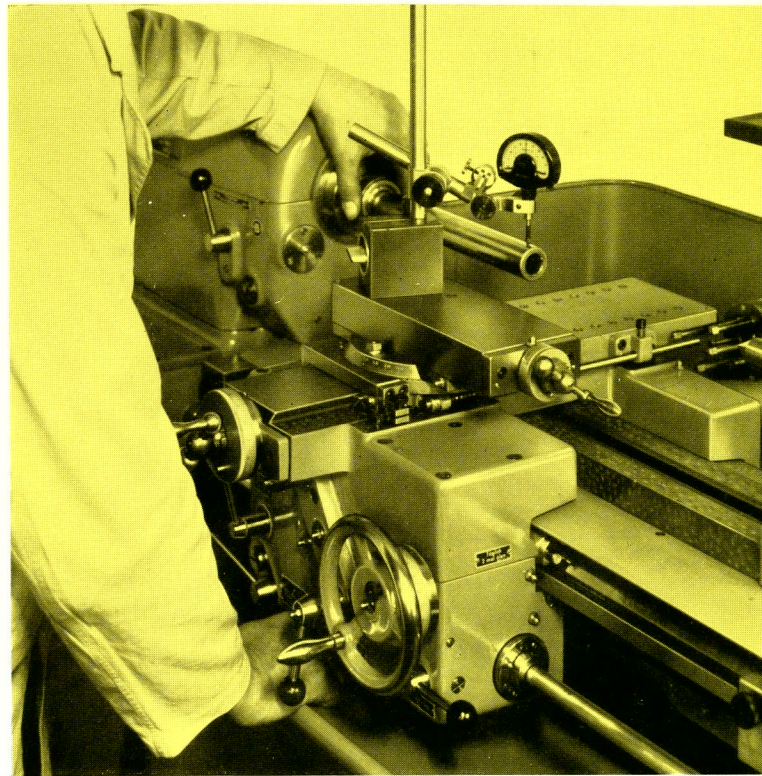

Material: Brass

Cutting tool: Diamond

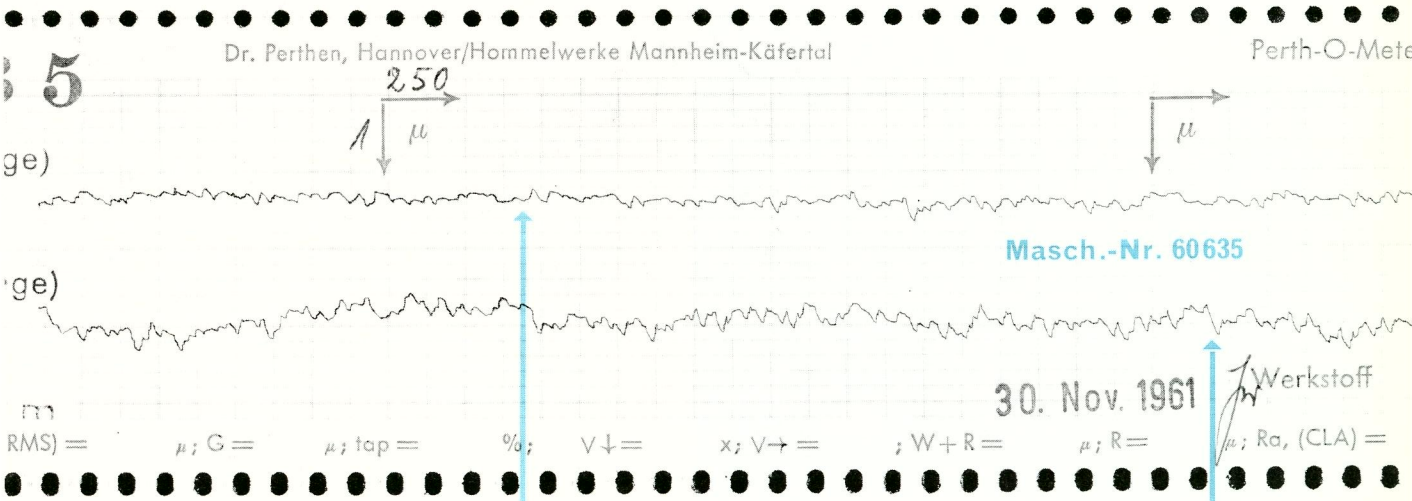
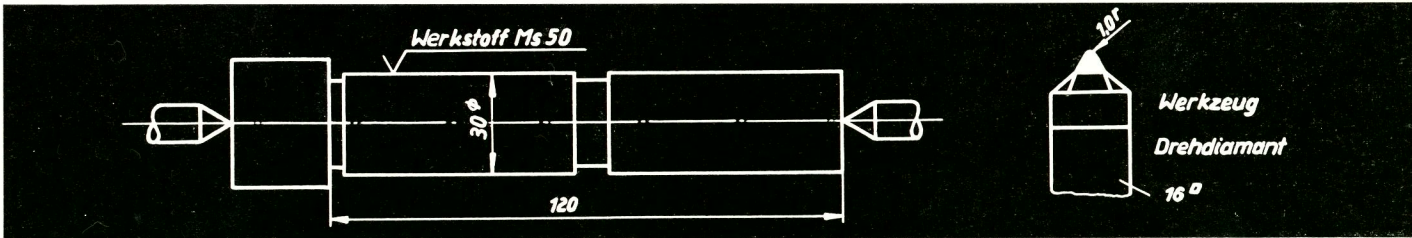

Surface-finish diagram of the test piece illustrated above

Details of Machining tolerances:
n = 1400 r.p.m. (without countershaft)

R = 0,28 μm or
RMS = 2-4 micro-inches

n = 2800 r.p.m. (without countershaft)
Feed = .02 mm. p. rev. (through
leadscrew) cutting depth = .05 mm.

R = 0,45 μm or
RMS = 3-7 micro-inches

Symmetrical in design
Easily reversed
Easily replaced

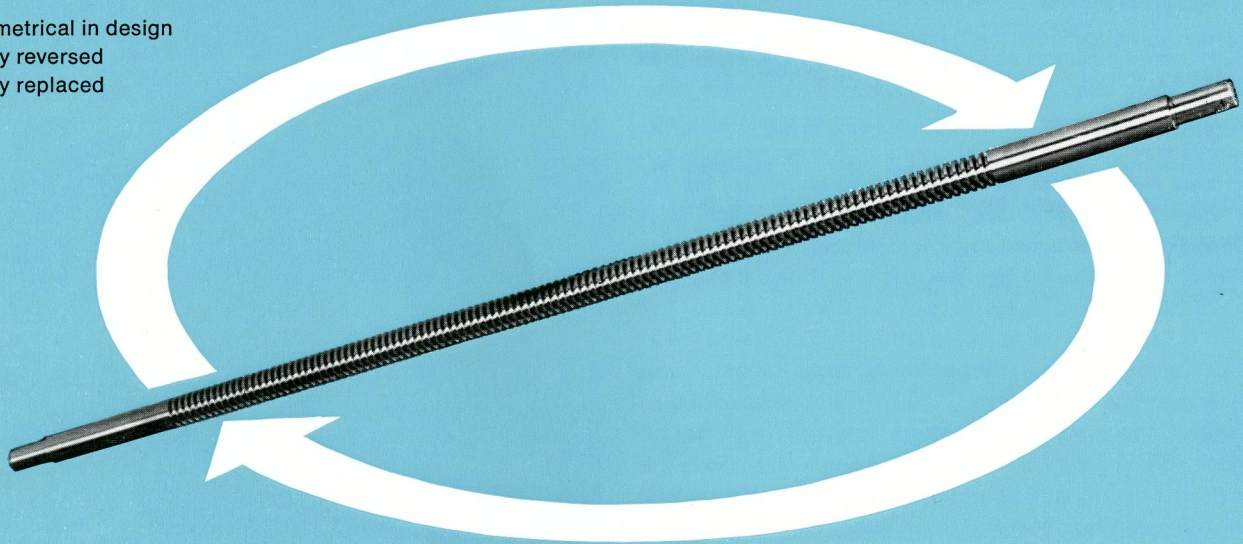

Guaranteed pitch accuracy of leadscrew when fitted in the machine: .02 mm. (about .0008") in 300 mm. (about 12").

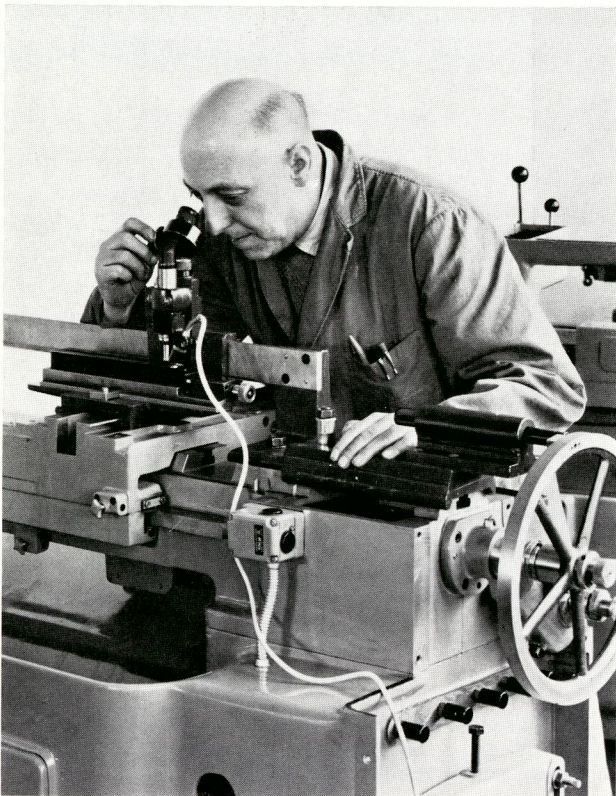

The leadscrew engages in the centre point of resistance in the saddle and obviates canting. It is driven through a reversing lobe and change-gears. When one flank of the leadscrew thread is worn and accurate threads can no longer be cut with it, the spindle can easily be reversed. The pitch accuracy, with the leadscrew fitted in the machine, is checked with super-precision optical instruments.

The machine is suitable for various methods of chucking:

Draw-in collet a 12, size 4, located direct in the spindle, the clamping being effected by means of a hand lever. Through bores up to 16 mm., blind bores up to 20 mm. If it is necessary to clamp components to exact identical lengths, an adjustable internal stop a 16 can be inserted in the collet.

Oversize collet a 18,4 and a 18,6, size 4, for short components with large diameters exceeding the clamping capacity of standard collets. The enlarged collets are supplied rough-machined and are finished by the users. They can be hardened after slotting. Special collets with spring ejector can be supplied, if required.

Expanding mandrels. Where the components are to be held in the bore, the expanding mandrels a 20 or expanding adaptors a 20,2, size 4, can be used, provided the eccentricity between bore and outside diameter of the component permits. Where concentricity must be very accurately maintained, the use of special chucks and expanding mandrels is recommended, e. g. "Stieber" roller clutch, or a similar clamping device.

For turning between centres, the driver a 33 with automatic clamping is used instead of dogs, which are not altogether safe and in any case, rather cumbersome. (No key is required for the driver.) The reliable and safe drive of the components is effected by means of three eccentric holding jaws, moved quickly by a tooth rim. A safety device is provided to prevent slipping when the gear-box brake is actuated.

Chucks of all types are available, but three-jaw or four-jaw chucks with a retaining device, are predominantly used.

Steadies. The travelling steady c 17,1 which is fixed on the carriage and has a maximum capacity of 58 mm., or the fixed steady c 19,1, whose jaws open to facilitate component unloading, with plain or roller jaws, can be employed.

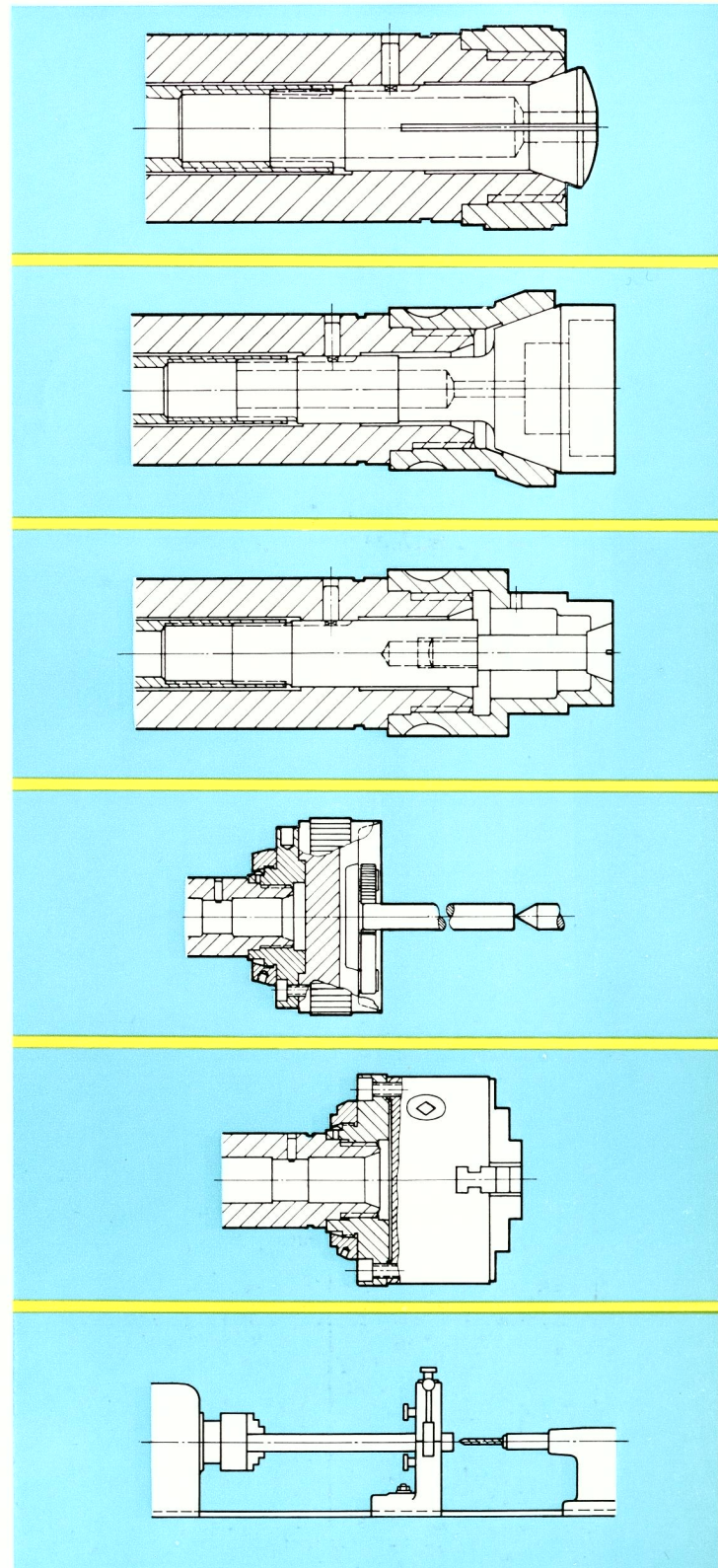

12 | Description of Machine

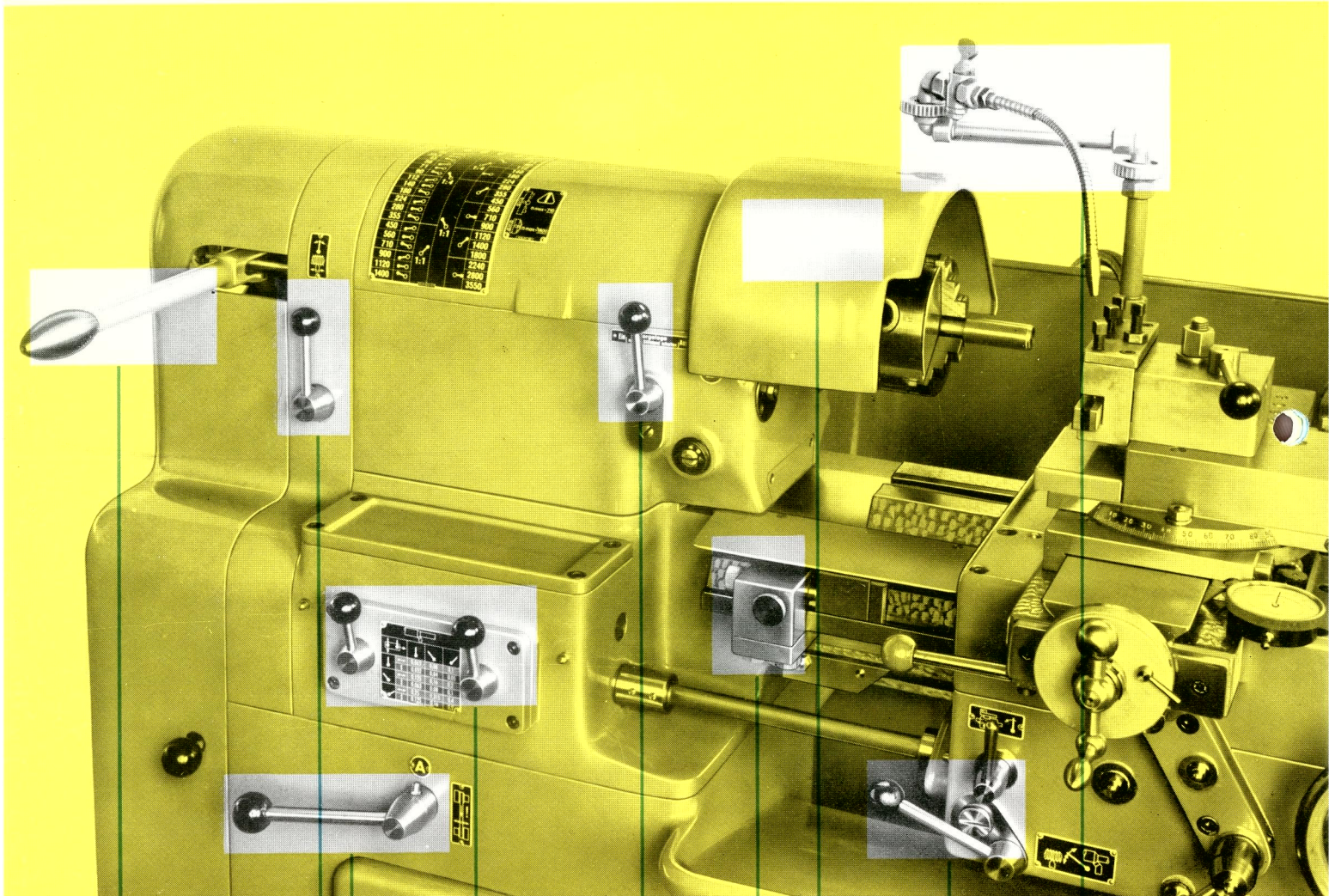

Hand-lever clamping

Reversing lever
for L.H. and R.H. threads

Sliding gear box
for 9 longitudinal
and 9 facing feeds

Belt-change
for altering speeds

Countershaft 1:4

L.H. longitudinal stop
for feed screw

Adjustable
splashguard g 89

Control lever for lead and feed screws
Automatic drop-nut release

Adjustable
coolant pipe

Headstock

The work spindle — not subject to the belt pull — runs in adjustable plain bearings of hardened bronze. The countershaft is controlled by a lever. Quick hand lever clamping is available when using collets.

When the motor is switched off, the spindle is immediately braked. On request, the spindle can be provided with an external steep taper to 3 DIN 55022 and an internal Morse taper No. 4 (together with spindle adaptor a 23, for use of collets a 12).

Drive and Spindle Speeds

The spindle speed wanted is quickly selected by switch. No drop of spindle speeds. Efficient drive.

The motor is arranged on an adjustable rocker, and the drive is transmitted to a gear-box 1:4 through a two-step vee-pulley. From here, the drive to the headstock is by means of a three-step flat belt pulley with a belt-changing device. The machine has 22 different spindle speeds in all, 18 spindle speeds in a lower, and 18 in a higher speed range.

Spindle speed range with lower speeds:

28 — 35 — 45 — 56 — 71 — 90 — 112 — 140 — 180 — 224 — 280 — 355 — 450 — 560 — 710 — 900 — 1120 — 1400 r.p.m.

Spindle speed range with higher speeds:

71 — 90 — 112 — 140 — 180 — 224 — 280 — 355 — 450 — 560 — 710 — 900 — 1120 — 1400 — 1800 — 2240 — 2800 — 3550 r.p.m.
The speed step for both ranges is 1.25.

Both speed ranges are available on the machine by shifting the vee-belt between the motor and the gear-box, and for this type of machine the number of speeds is unusually great. Most of the speeds can be engaged while the machine is running. Only while the spindle countershaft is engaged (the motor continues running) is the spindle temporarily stopped by means of an automatic brake. One lever only, conveniently arranged, is used for controlling the multi-disc clutches and brake. This hand lever is also used for controlling the forward and return traverse of the carriage when threading individual components and for setting the semi-automatic or fully automatic carriage cycle for threading in batch production.

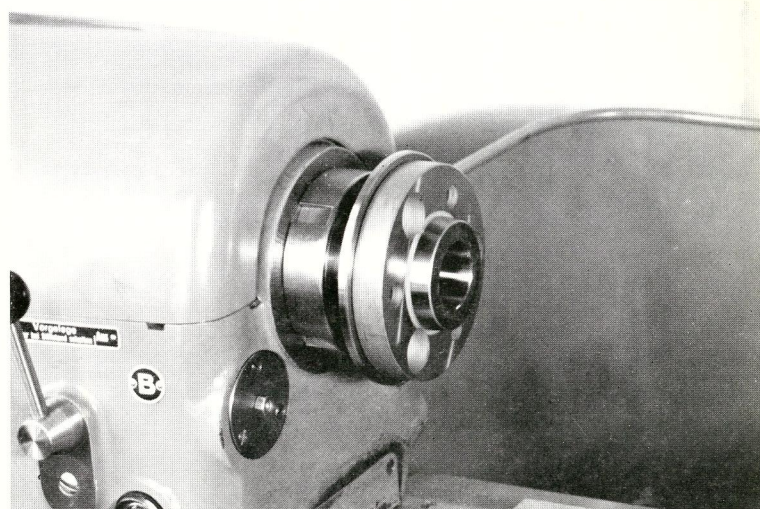

Special design of spindle nose

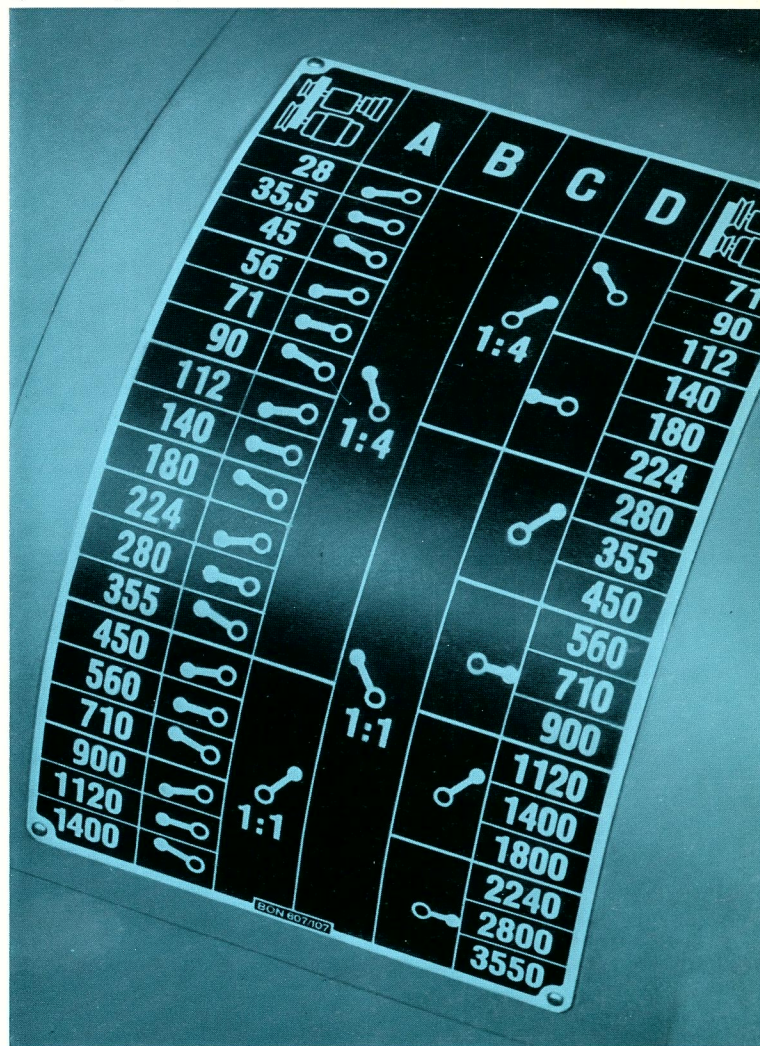

- A Belt shift.
- B Layshaft.
- C Control switch.
- D Pole-change reversing switch.

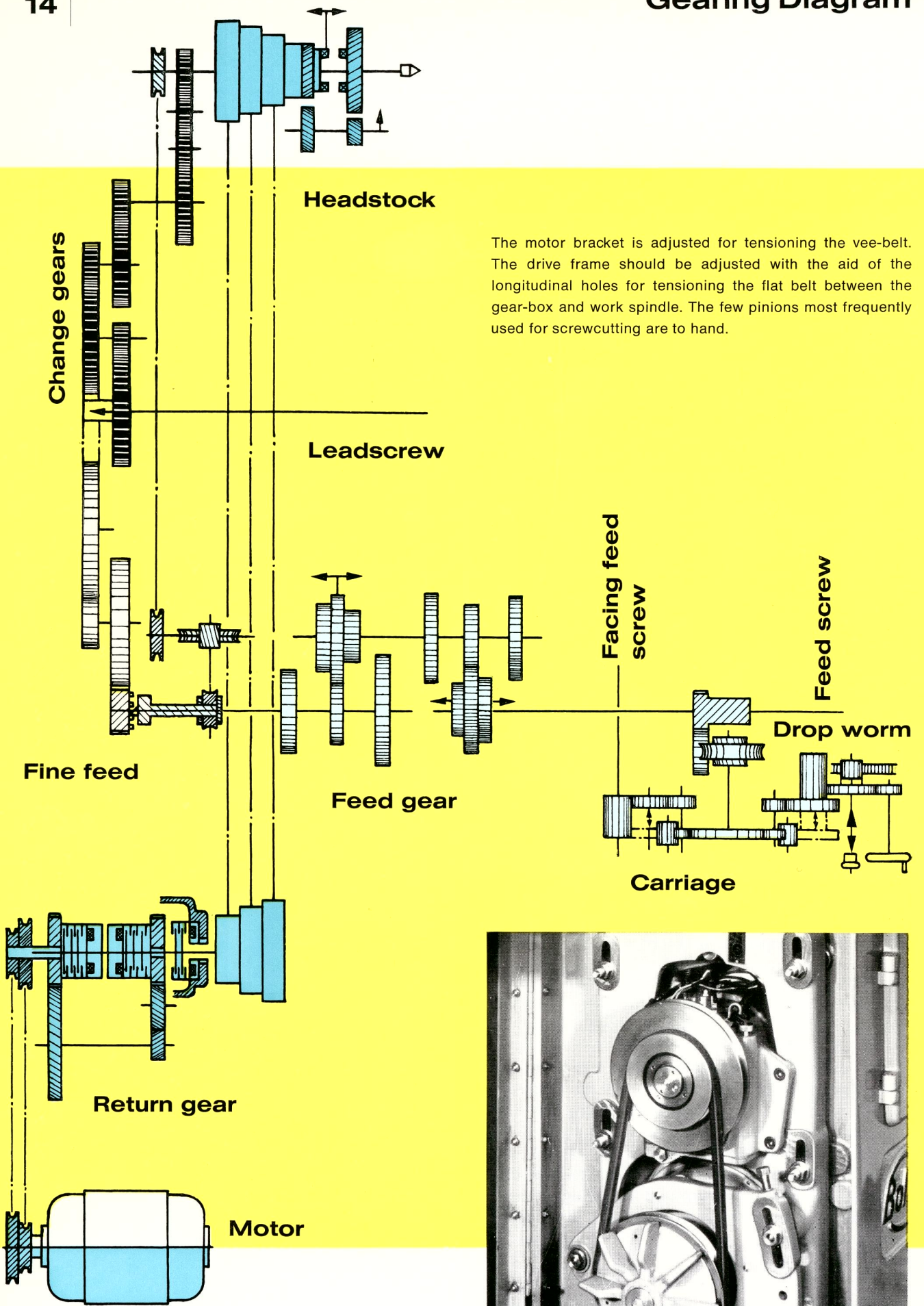

The motor bracket is adjusted for tensioning the vee-belt. The drive frame should be adjusted with the aid of the longitudinal holes for tensioning the flat belt between the gear-box and work spindle. The few pinions most frequently used for screwcutting are to hand.

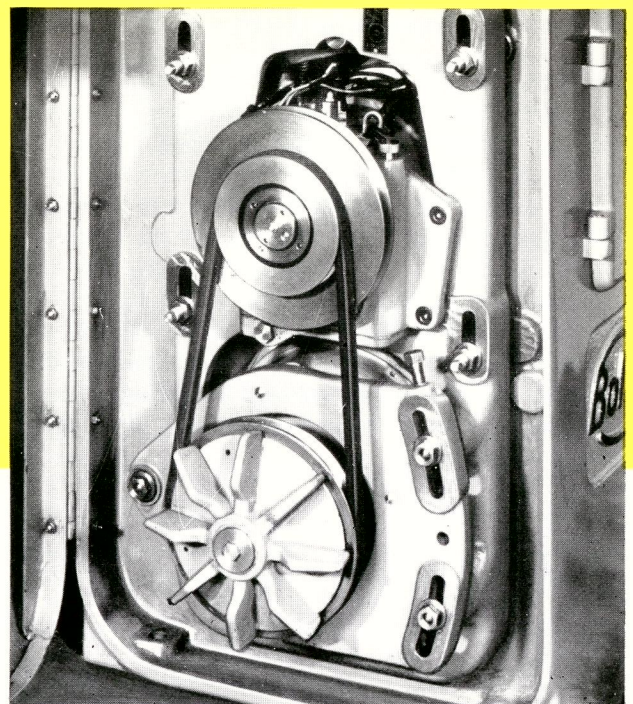

Driving motor and gear box

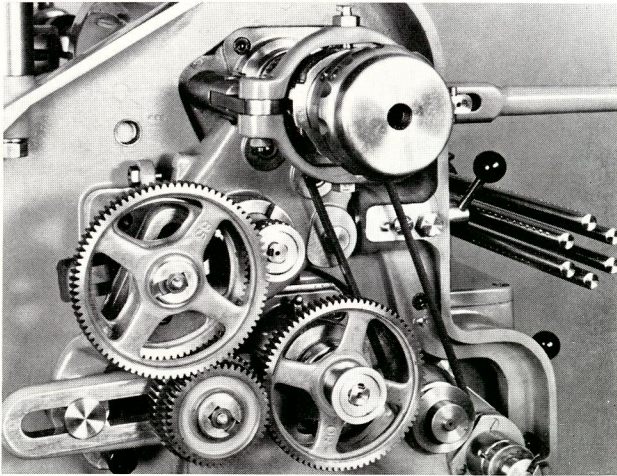

Auxiliary shears for unusual threads

The fewer change-gears are in mesh, the more accurate are the threads. Only 3 change-gears are required for pitches from 1 to 7 mm. Practically every pitch can be set with sufficient accuracy.

Example:

To change over from 1.25 to 3 mm. pitch, **only one** pinion has to be changed, a 25-tooth pinion being replaced by one with 60 teeth, as can be seen from the change-gear table below.

The space provided for the change-gears is so ample that additional auxiliary shears and change-gears can be utilised to produce the most unusual pitches with a high degree of accuracy.

mm	a	b	c	d
0,01	30	120	25	127
0,0125	40	120	25	127
0,016	50	120	25	127
0,02	65	120	25	127
0,025	50	120	40	127
0,0315	30	85	60	127
0,04	30	60	55	127
0,05	50	60	40	127

BON 377/92b

Superfine feeds for fine turning

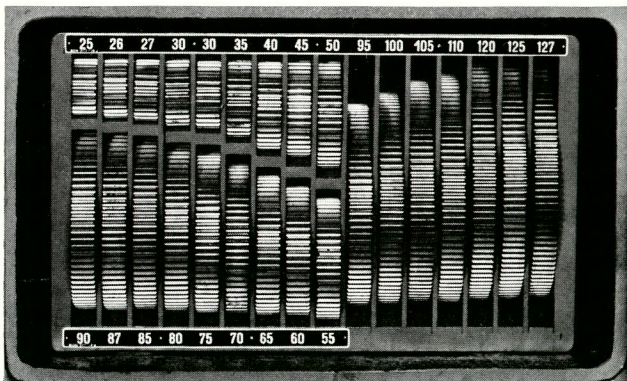

This is how the change-gears are stored in the righthand side of the front of the machine.

Change-gear Table

G. BOLEY Werkzeug- u. Maschinenfabrik Eßlingen/Neckar

$\frac{a \cdot c \cdot e}{b \cdot d \cdot f} = \frac{\text{mm}}{4}$

mm	Zoll - INCH - Pouce				Modul											
	a	b	c	d	a	b	c	d	e	f						
0,2	30	120	25	125	80	30	90	25	105	0,3	26	120	87	80		
0,25	30	100	25	120	72	30	85	30	120	0,4	26	120	87	60		
0,3	25	120	45	125	64	25	85	27	80	0,5	50	80	87	40	26	90
0,35	25	80	35	125	60	25	85	45	125	0,6	65	120	87	100		
0,4	25	60	30	125	56	25	70	27	85	0,7	26	60	87	30	35	80
0,45	30	80	30	100	48	25	85	45	100	0,8	26	90	87	40		
0,5	25	60	30	100	44	25	65	45	120	0,9	26	80	87	40		
0,6	30	60	30	100	42	45	85	30	105	1	26	60	87	30	50	80
0,7	35	60	30	100	40	40	70	25	90	1,2	26	40	60	80	87	45
0,75	25	40	30	100	36	25	85	60	100	1,25	25	40	65	80	87	45
0,8	40	60	30	100	32	50	85	27	80	1,4	35	40	87	50	65	90
1	25	120		100	30	50	85	45	125	1,5	26	40	87	80	100	60
1,25	25	120	80		28	30	85	45	70	1,6	26	45	87	30	60	80
1,5	30	120		80	26	30	65	45	85	1,75	35	30	87	60	65	80
1,75	35	120		80	24	35	70	45	85	1,8	26	40	87	80	120	60
2	40	120		80	22	30	55	45	85	2	26	40	75	60	87	45
2,5	50	120		80	20	30	120	127	100	2,1	26	30	87	80	105	60
3	60	120	80		19	30	120	127	95	2,25	45	30	65	60	87	80
3,5	35	120		40	18	30	120	127	90	2,4	26	30	87	45	90	80
4	30	120		30	17	30	120	127	85	2,5	50	30	65	60	87	80
4,5	45	120		40	16	25	100	127	80	2,7	26	30	90	40	87	80
5	50	120		40	15	25	125	127	60	2,75	55	30	65	60	87	80
5,5	55	120		40	14	30	120	127	70	3	30	30	65	60	87	40
6	60	120		40	13	30	120	127	65	3,25	27	45	90	25	65	55
7	70	120		40	12	25	80	127	75	3,5	35	30	65	60	87	40
8	40	30	90	60	11	25	110	127	50	3,75	50	30	65	80	87	40
9	45	30	90	60	10	45	120	127	75	4	50	30	65	75	87	40
10	50	30	90	60	9	35	70	127	90	4,5	45	30	65	60	87	40
12	60	30	75	50	8	35	80	127	70	5	50	30	65	60	87	40
14	70	30	75	50	7	40	80	127	70	5,25	65	30	70	80	87	40
16	40	30	90	30	6	35	70	127	60	5,5	65	30	55	80	87	30
18	45	30	90	30	5	35	70	127	50	6	65	40	90	60	87	45
20	50	30	90	30	4 1/2	35	70	127	45	6,75	65	40	87	80	90	30
22	55	30	90	30	4	30	80	127	30	7	70	40	87	30	65	60
24	60	30	90	30						7,5	65	30	75	60	87	40
										8	65	30	80	60	87	40

25-26-27-30-30-35-40-45-50-55-60-65-70-75-80-85
87-90-95-100-105-110-120-125-127

BON 377/93a

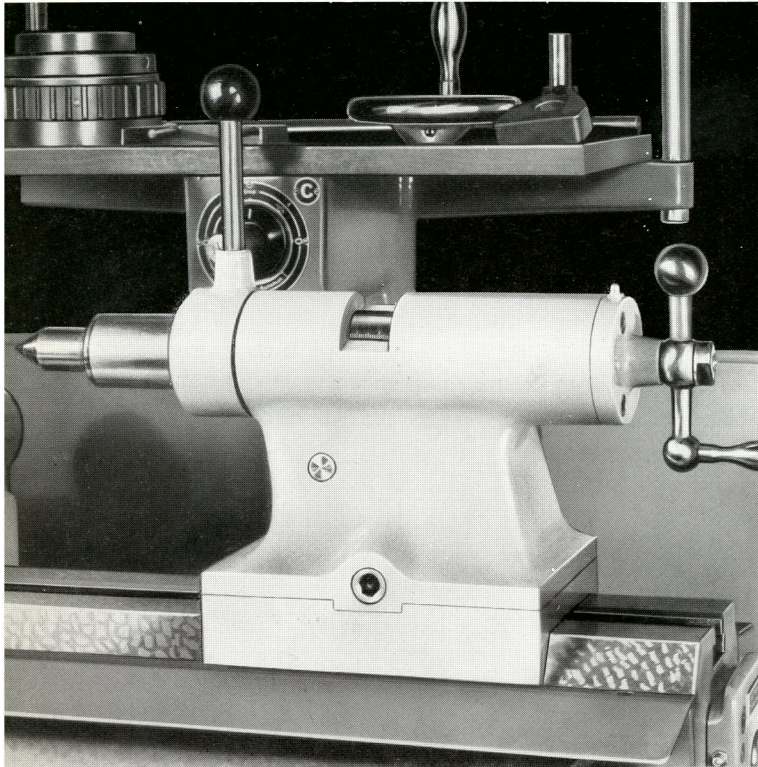

Tailstock

Sleeve with 40 mm. diameter, hardened, Morse Taper 3. Sleeve movement 80 mm. This can be read off a scale on the tailstock body. The sleeve can be fixed concentrically (no centre line displacement). The tailstock can be adjusted for taper turning 10 mm. to either side.

Special tailstock with a dividing ring can be supplied, if required.

Machine base

Made from one casting. The weight of the machine, in conjunction with vibration-eliminating properties of cast iron, ensure quiet running of this high-speed machine. To facilitate cleaning, the machine is smooth.

It is suitable for operating from a sitting or a standing position, so that it is best suited for batch production and can be operated by personnel with leg disabilities.



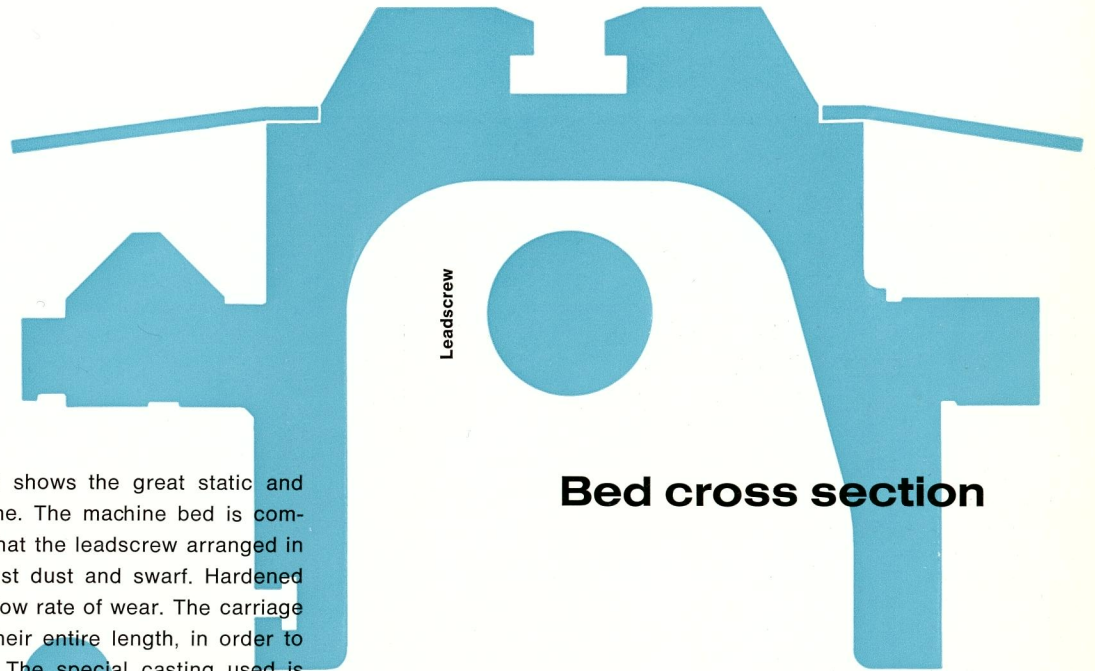

Bed cross section

The section through the bed shows the great static and dynamic rigidity of the machine. The machine bed is completely closed at the top, so that the leadscrew arranged in the middle is protected against dust and swarf. Hardened saddle slideways — ensuring low rate of wear. The carriage slideways are covered over their entire length, in order to keep out swarf and coolant. The special casting used is highly resistant to wear. The original accuracy is maintained for many years if the machine is properly serviced.

The leadscrew engages in the centre of resistance of carriage

Feedscrew



Assembling the bed and carriage

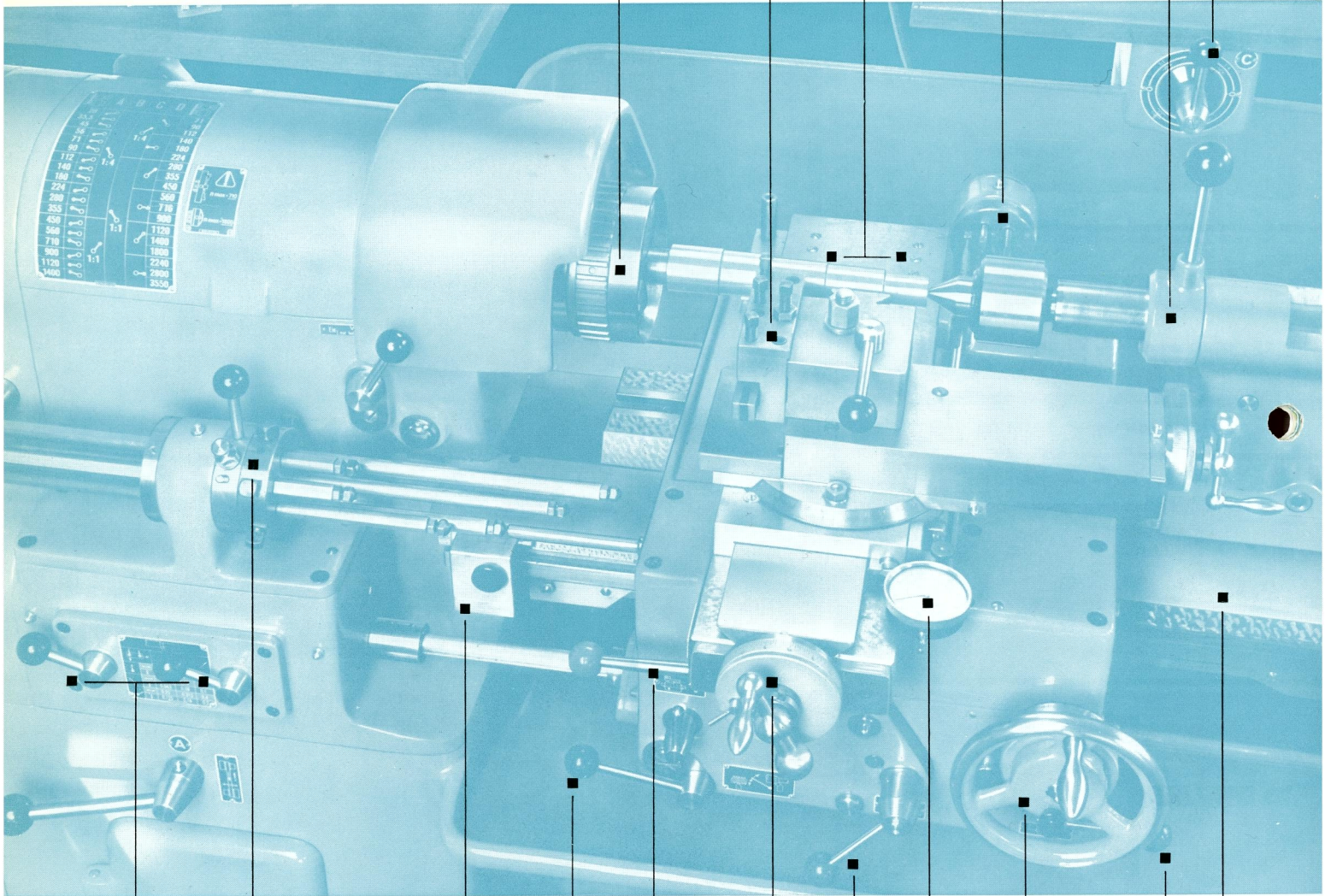

1

2

3

4

5

6

7

8

9

10

11

12

13

14

15

16

17

- 1** Automatic driver a 33
- 2** Quick-change toolholder d 30
- 3** Mounting bores for rear toolholders
- 4** 6-Station facing stop b 34
- 5** Concentric sleeve clamping device
- 6** Control switch for spindle and carriage movement when screw-cutting (for electro-magnetic clutches in the gear box)
- 7** Sliding gear for 9 longitudinal and 9 cross feeds
- 8** 6-Station longitudinal stop d 31
- 9** L. H. longitudinal stop for feed screw
- 10** Control lever for lead and feed screws
- 11** Selector lever for facing "forwards" or "return"
- 12** Large chromium-plated scale ring
- 13** Selector lever for longitudinal turning "left" or "right"
- 14** Clock gauge for accurate cross positioning
- 15** Handwheel with scale ring for quick carriage adjustment
- 16** Disengaging lever for feed screw
- 17** Slideways, covered over the entire length

Longitudinal turning and facing by means of feed screw can be done in both directions, employing adjustable stops. The longitudinal stop is provided with a fine adjustment screw and can take a slip gauge. If required, a six-station turret stop can be supplied for carriage and facing slide. Moreover, a clock gauge can be arranged on the facing slide. The drive of the feed screw from the headstock is by means of vee-belts, and not gears, so as to eliminate vibration. Nine different feeds can be set while the machine is running, with the aid of two levers on the sliding gear box. When the feed screw is used for turning against the hardened stop, a drop worm is released. The releasing pressure can be easily adjusted. The carriage can be clamped for facing. When precision turning with a very small feed (less than .05 mm. or .0019") the feed screw can drive the leadscrew by means of pick-off gears. The minimum feed is .01 mm. per rev. (= .0004"). The handwheel on the righthand end of the feed-shaft and the overrun clutch make rapid adjustment possible with the spindle nut closed. The leadscrew is arranged in the centre line of the bed and engages the carriage at the focal point of resistance. It is completely protected against coolant and swarf. The arrangement prevents canting. The handwheel on the apron, conveniently arranged, serves for easy adjustment of carriage, with the aid of its scale (one division mark = .1 mm. or .004"). This is of great advantage for drilling and boring work. The depth adjustment is by means of a graduated ring. The handwheel can be fixed for screw-cutting. The feed and leadscrew are controlled by one and the same lever and are therefore interlocked.

The large scale ring, 80 mm. diameter (= 3 $\frac{1}{8}$ "), is used for exact readings on the carriage (one division = .05 mm. diameter or .025 mm. slide traverse. If required, the screw can be provided with a 2 mm. pitch [= .079 "] and a scale ring graduation of .02 mm. [= .0008"] in relation to the diameter). The sturdy screw, with 4 mm. (= .157") pitch in the longitudinal and cross slide, affords the advantage of quick adjustment. All slideways are provided with taper gibs. The top slide can be swivelled to either side through angles up to 90°. The graduation is clearly visible from the operator's position. Rear toolholders can be supplied for parting-off and recessing tools, edge-breaking tools, etc. The adjustable toolpost d 6,6, or the rear facing slide d 6,71 described in catalogue De 25, are used for this purpose.

Screwcutting with automatic II and attachment d 32
(Description of d 32 on Page 22)

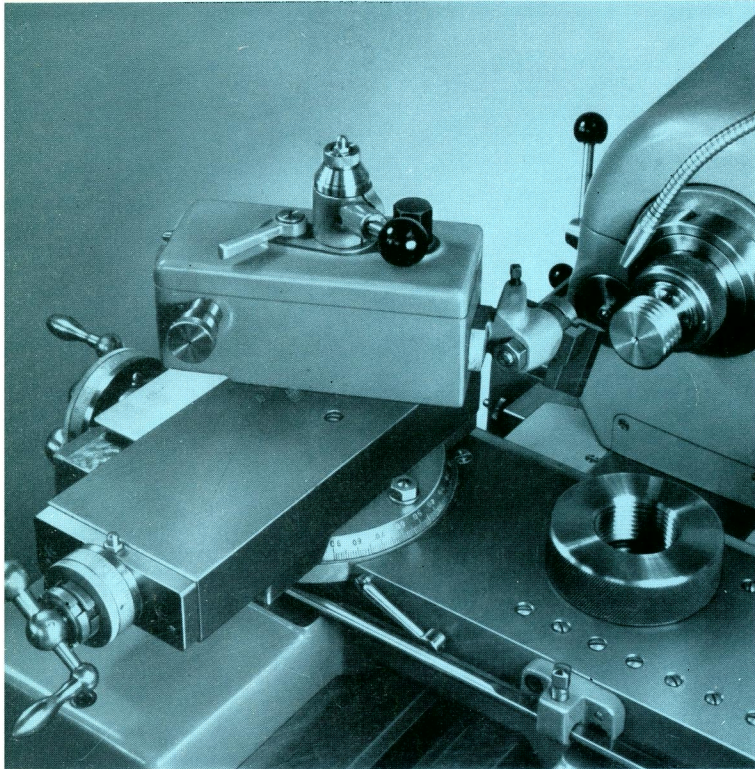

Screwcutting

With the set of change-gears supplied (25 gears in all, accommodated in the machine base) it is possible to cut all the usual millimetre and inch threads with pitches from .2 to 20 mm. and from 80 to 4 T.P.I. L.H. and R.H. Module threads from .3 to module 8 can be cut. The return traverse has quadruple acceleration by electric reversal of the gear-box whilst the motor is running. When producing single components, the forward and return traverse of the carriage is controlled with the aid of a manually-operated lever (see No. 6 as illustrated on page 18). Even with small batches of components, it is economical to use the automatics I or II (German patent applied for).

Automatic I

The control lever (No. 6, page 18) is set for automatic reversal. The carriage moves to the left towards the limit switch at screwcutting speed. On reaching the limit switch, the return traverse speed is quadrupled. The carriage then moves to the right towards a second limit switch, which cuts out the work spindle and carriage movement, thus bringing them to a stop.

Automatic II

Here, the forward and return traverse of the carriage is carried out automatically. Normally, the fully automatic control mechanism can be used for right-hand threads only, but it can be arranged for cutting left-hand threads, if required.

Fully automatic control mechanism

Automatic Operation

High frequency of reversal for screwcutting. The automatic mechanisms I and II can be fully utilised with the aid of the screwcutting attachment d 32, illustrated and described on page 23. All the operator has to do is to move the lever of the screwcutting attachment against the stop at each pass. This method of operation – the use of automatic mechanisms with the screwcutting attachment – accelerates screwcutting considerably as compared with the usual methods. Screwcutting is made so simple that even unskilled labour can be employed for faultless operation, once the machine has been set.

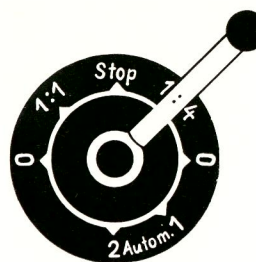

Control switch for spindle rotation and carriage movement

Slow forward traverse for screwcutting, automatic reversal by means of limit switches to four times accelerated rapid return. Standstill

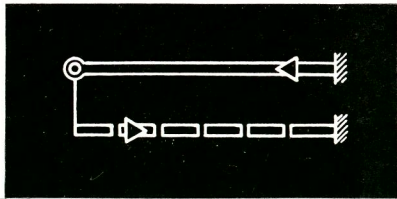

Automatic reversal by means of limit switches

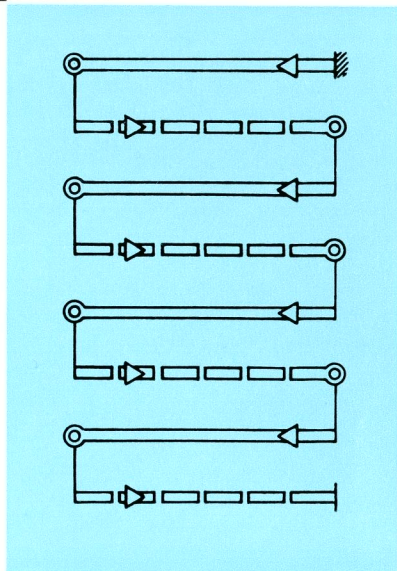
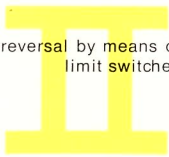

We give below a brief comparison between the change-gears and the Norton gear-box: More gears engage in the Norton gear-box than on the 5 LZ machine. However, the fewer the gears, the higher the accuracy. If, for example, a thread with 7 mm. pitch is to be cut after a thread with 1.25 mm. pitch, only one or, at the most, two gears have to be changed. The gear change is effected quickly and without the aid of any keys, as the gears are secured in position by locking discs. — As already mentioned, the leadscrew is driven through change-gears and the feed screw through the feed gear-box. **The thread pitch and feed are set once, independent of each other**, so that components can be turned rationally in one setting with any desired feed and any pitch of thread. For turning operations, **a single lever is used** for starting the feed screw. The same lever is used to start the leadscrew for screwcutting. It will be seen, therefore, that only **one** lever has to be operated, this being yet another advantage over the Norton gear-box.

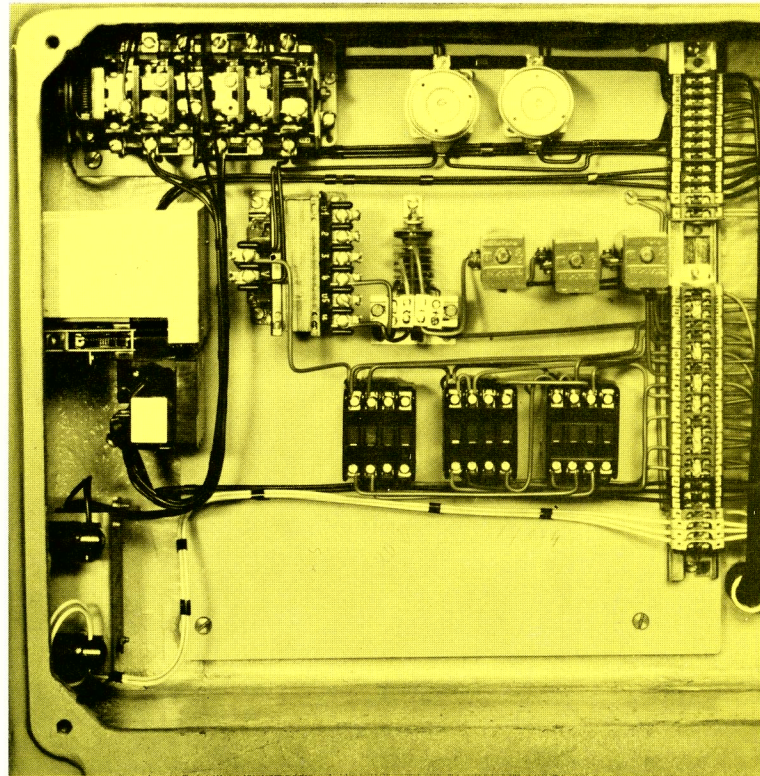

Electric Equipment

Double pole-change flange-type motor, main motor and immersion pump protected by separate motor overloads. Power points for lighting and for connecting various attachments (grinding, milling, etc.), tell-tale lights for main motor and pump. Switchgear clearly arranged and easily accessible at the right-hand end in the machine base.

The illustration shows the accessibility and clear arrangement of the switchgear. The change-gears not required are kept in a compartment under the switchgear.

The switchgear is included in the price of the machine.

Quick-change toolholder d 30

No lathe should be without this equipment. The quick-change toolholder is equally suitable for production of single components or for mass production. Here, any number of tools can be set and used in any sequence. The purpose of the toolholder is to facilitate the change of tools and to speed up the process. It consists of a fixed clamping body with hardened and ground guides and of various holders, easily interchangeable. The holders are arranged and fixed in the guides of the clamping body, in a horizontal or vertical position, according to the type of work to be done. A lever is used for clamping the holders in position.

The height of the turning tool can be set with a stop screw. When a tool is changed, no re-adjustment of the height is required and no re-setting of the calibrated ring necessary. For centre and twist drills special toolholders are provided. As the holders can be removed, the tools can be easily reground whilst remaining clamped in the holder. Special holders are used for centring tools and twist drills, so that the automatic feeds to the carriage can be utilised for the drilling operations. A swivelling toolpost is also available where this is preferred.

Screwcutting Attachment d 32

(description on page 20) (German patent applied for).

This incorporates semi-automatic infeed and is used instead of the ordinary toolholder. The screwcutting tool is moved backwards and forwards by means of a lever, and the tool infeed is effected automatically. The overall infeed can be pre-set to scale with the aid of a rotary button (max. 4 mm.). The infeed cam is so arranged that the finishing cuts are carried out with a reduced infeed until this finally reaches zero. Moreover, it is possible to determine beforehand the number of cuts (6 to 24), according to the material machined and depth of thread required. The cutting tool is fed in at an angle of 26°. Thus, the stock is removed mainly at the left thread flank, whereas the right flank is only lightly scraped.

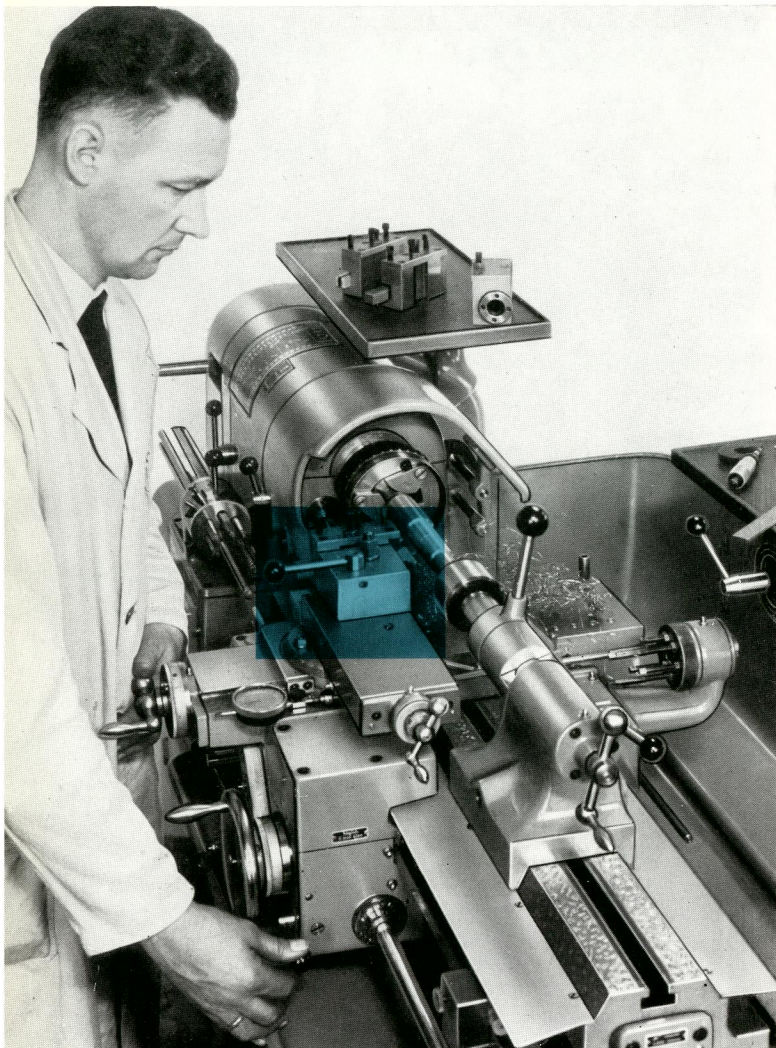

Turning with the quick-change toolholder

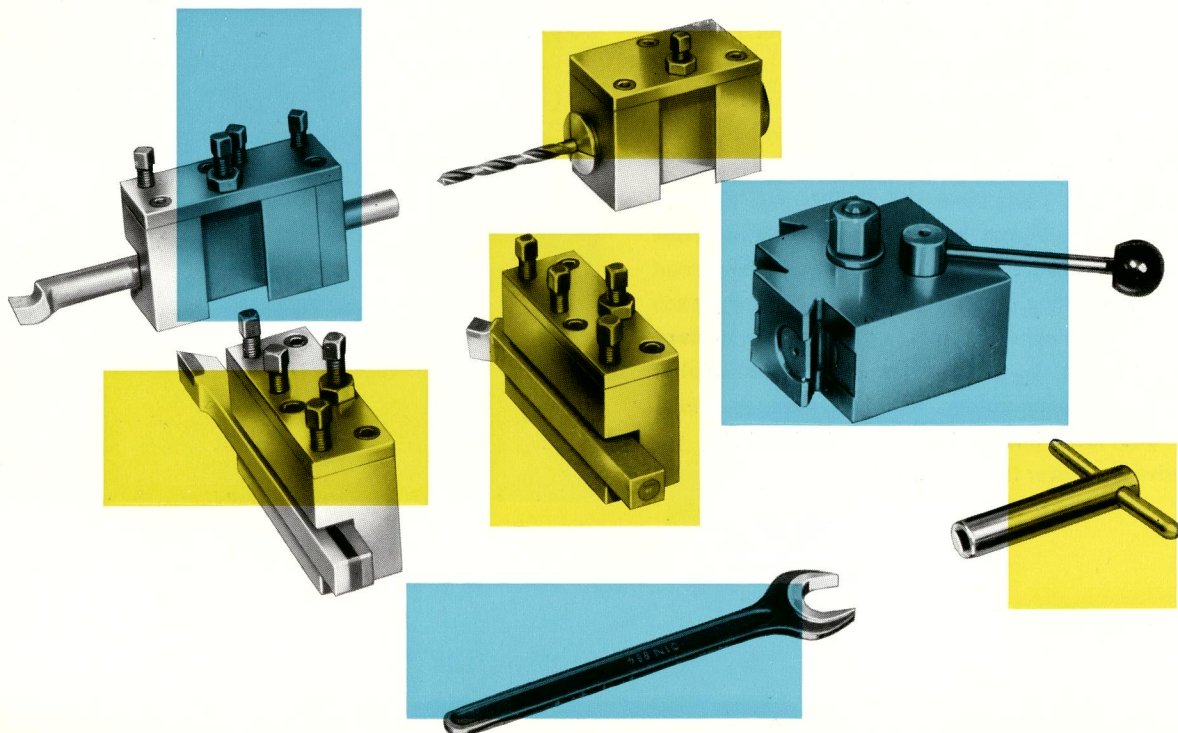

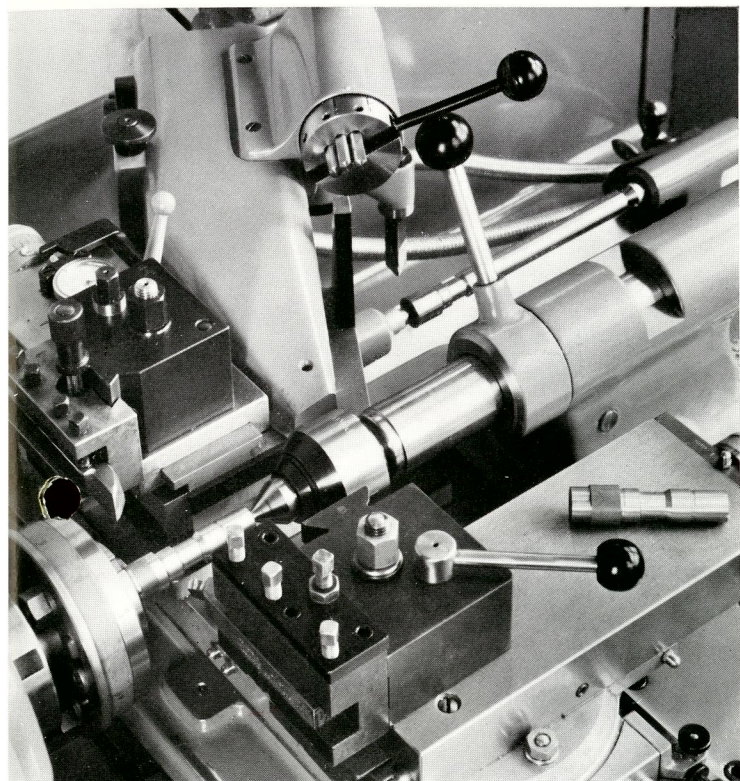

Hydraulic Copying Attachment d 35

comprising the copying unit, the anchorage for the master shafts and the hydraulic drive.

Maximum cross-section of cut	1 sq. mm.	.00155 sq. inch.
Diameter of plunger	50 mm.	2"
Stroke of plunger	60 mm.	2 ³ / ₈ "
Maximum difference in diameters	100 mm.	4"
Copying length	500 mm.	20"

The copying attachment is designed for longitudinal copying and works to master shafts. It is mounted at the back of the facing slide at an angle of 60° to the centreline. This still enables facing to be done entirely satisfactorily and also profiles to be turned, which drop off at angles up to 30° towards the back. Components with an angle of drop larger than 30°, for instance 90°, must be finish copy-turned in a second operation, after turning the component round, as is customary with standard turning. These portions of the component, which are not to be copy-turned, can be machined with the standard front toolholder. In many cases, outside diameters can be roughed out with the front tool or an inside diameter bored out, while the component is being copy-turned from the back.

For heavier cuts, multi-cut attachment with turret for three roughing cuts and one finishing cut.

The control accuracy is 5 to 7 microns. This is also affected by other factors such as, for example, tool wear, build-up on the cutting edge, heating and deflection of the component.

The master shaft is held between the centres of two tailstocks, the guide for which is mounted on two bearers. Both bearers are fitted at the back of the lathe bed and firmly bolted to the boxtype base.

For longitudinal adjustment, one of the tailstock centres is easily adjustable by means of a spindle and calibrated knob, while the other tailstock has built-in plate type thrust springs. Cross adjustment to ensure parallelism of the component can also be effected by setting the guide for the tailstocks by means of a spindle and calibrated knob. As follower, a double-edged stylus is built into the copying slide. The hydraulic unit, working at a pressure between 210 and 485 lbs. per sq. inch, is arranged alongside the machine. It is connected up to the copying attachment by two hoses.

A quick-change toolholder is used to ensure rapid interchange of copying tools and is included in price.

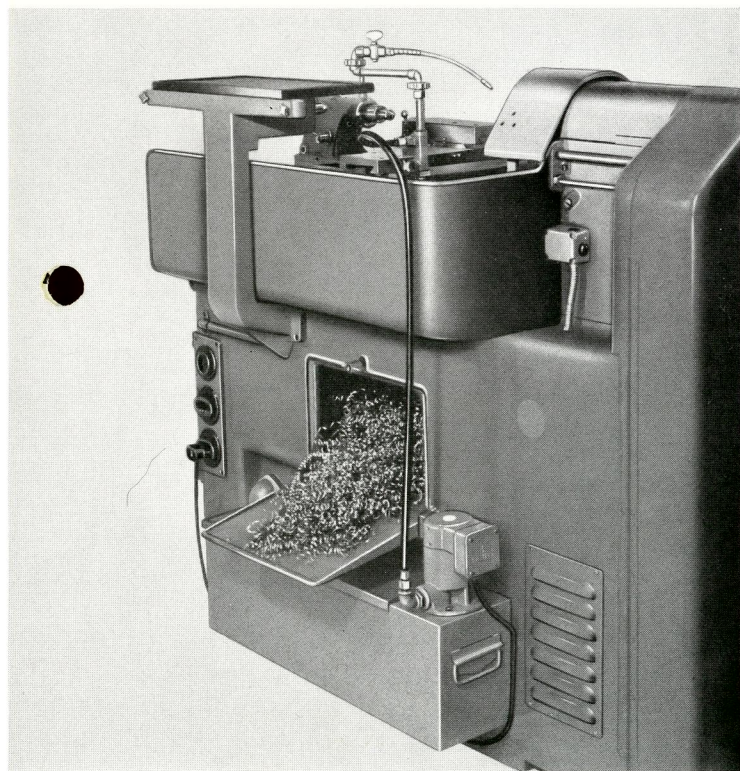

Coolant attachment g 65,2

This consist of: electric pump with motor overload and tell-tale lights on the right leg of the machine base, coolant tank, metal hose, including travelling coolant jet. The coolant tank, which holds about 6³/₄ gallons and also accommodates the pump, is arranged at the rear of the machine and is easily accessible. For cleaning purposes, the tank can be easily lifted out, with the aid of two handles. The flexible metal coolant hose is adjustable, so that the coolant can be conveyed to the bore for internal turning or drilling.

5 LZ

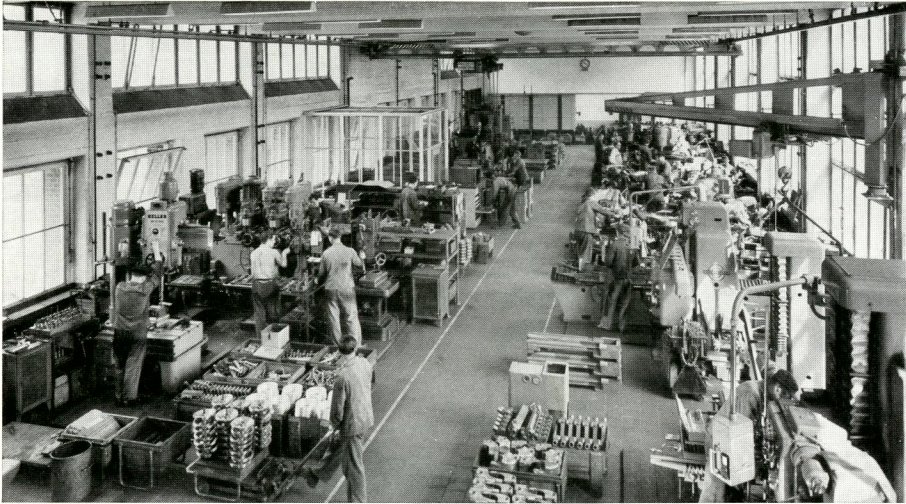

Machining individual components on modern high-duty machines



Assembly line
Bed and carriage assembly
Testing the reversing gear



Assembly and inspection of finished machines

- b 22 Self-releasing dieholder for b 20, for dies
16 mm. dia. × 5 mm.
- b 22,1 20 mm. dia. × 5 mm.
- b 22,2 20 mm. dia. × 7 mm.
- b 22,4 25 mm. dia. × 9 mm.
- b 22,6 30 mm. dia. × 11 mm.
- b 22,7 38 mm. dia. × 10 mm.
- b 22,8 38 mm. dia. × 14 mm.
- b 25,1 Live centre
- b 27,5 Drill chuck, 0–10 mm. dia., for screw-operated tailstock
- b 29 Centre (= a 25) with a 24 for headstock and lever-operated tailstock b 4
- b 29,2 Half centre, MT 3
- b 29,4 Tungsten carbide centre MT 3
- b 29,5 Centre MT 3
- b 30 Female centre MT 3

- c 14,2 Handrest, collapsible
- c 17,1 Travelling steady
- c 19,3 Fixed steady, collapsible
- c 19,4 Roller jaws for c 19,3

- d 6,3 Double toolholder
- d 6,6 Adjustable toolpost
- d 6,71 Rear facing slide
- d 6,8k Swivelling lever-operated slide
- d 8,1 Four-sided swivelling toolholder, for operation by one hand (special mounting holes)
- d 8,5 Four-station turret
- d 12 Vertical slide

- d 30 Quick-change toolholder (see illustration on page 22), consisting of:
d 30,1 – clamping body
d 30,2 – three holders for turning tools
d 30,3 – Holder for collet a 12, size 4 (without collet), to take drills, reamers, etc.
d 30,4 – Vee-shaped insert for d 30,2
- d 31 6-station longitudinal stop (see illustration on page 18)
- d 32 Screwcutting attachment with semi-automatic infeed (illustration and description on page 23)
- d 32a Toolholder for internal thread cutting with d 32
- d 34 6-station facing stop (see illustr. on page 18)
- d 35 Hydraulic copying attachment with multi-cut attachment (see page 23)

- g 65,2 Coolant attachment
- g 77a Drawing holder
- g 80 Workpiece tray
- g 83,1 Operator's stool with backrest, sitting height 70 cm.
- g 88 Lighting
- g 89 Adjustable splash guard

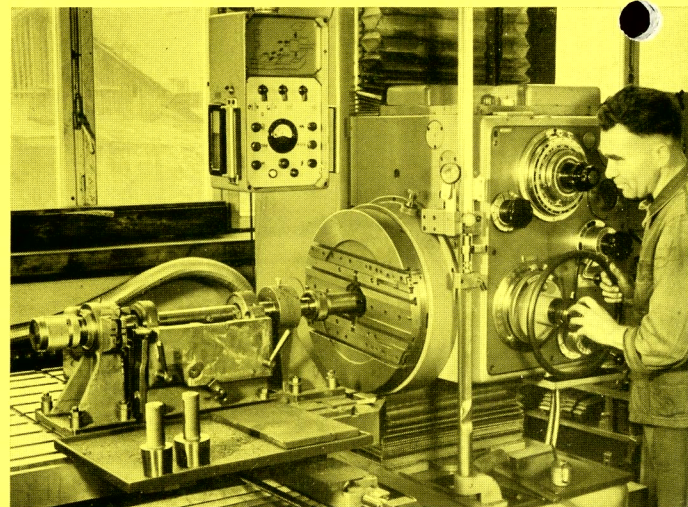

Machining headstock bodies on a broaching mill.



Assembly of parts
The slide assembly can
be seen in the foreground

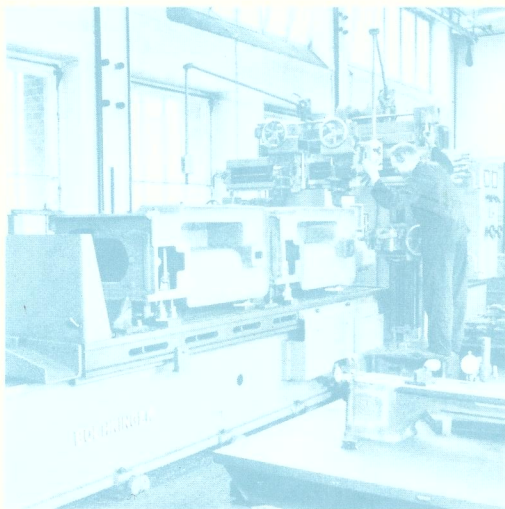

Planing the massive machine bases

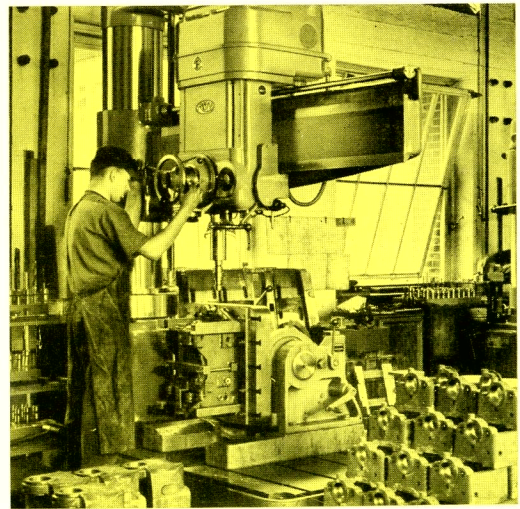

Drilling headstock bodies

We reserve the right of making modifications without prior notification. Illustrations and principal dimensions without engagement.



Small Precision Lathes

Mechanics' Lathes

Finish-turning Lathes

**Semi-Automatic Finish-turning Machines
with cam-controlled saddle**



G. BOLEY - 73 ESSLINGEN

Finest Turning Lathes

Turret Lathes

Automatic Capstans

Small Fine-drilling Machines

Multi-spindle Drilling and Tapping Machines

Watchmakers' Tools and Parallel Vices