

Steigungstabellen am Spindelstock
 Z = 30 - 60
 Millimeter-Gewinde
 Zwischenrad Wahlweise

Z = 24-120-127-z
 Zollgewinde

Z = 44 - 56
 Millimeter-Gewinde
 Zwischenrad Wahlweise

Steigung der Leitspindel : 6 mm

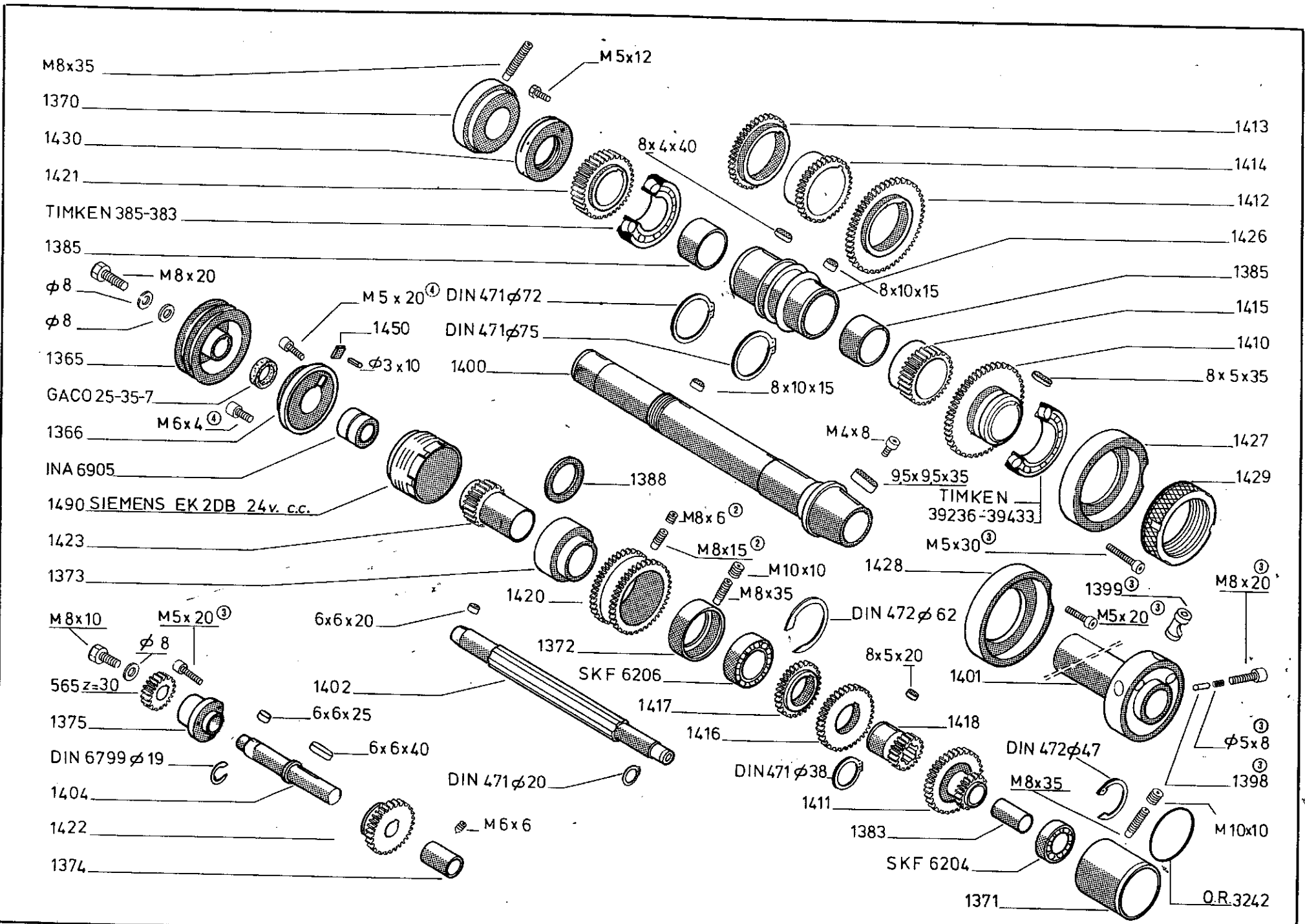

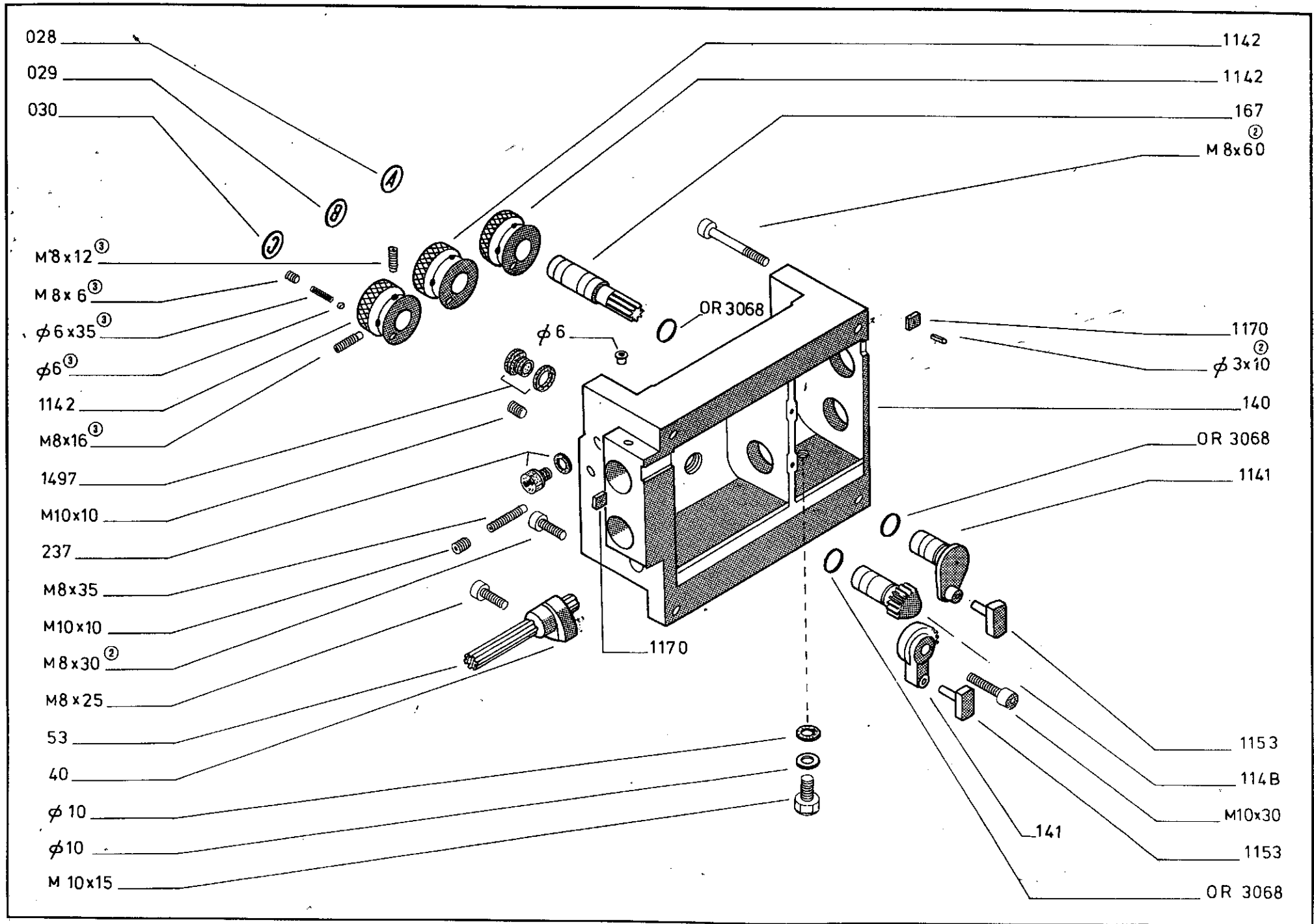

SCATOLA A FILETTARE E TORNIRE

BOITE DE FILETAGE ET CHARIOTAGE

GEWINDERÄDER- UND VORSCHUBKASTEN

THREADING AND TURNING BOX

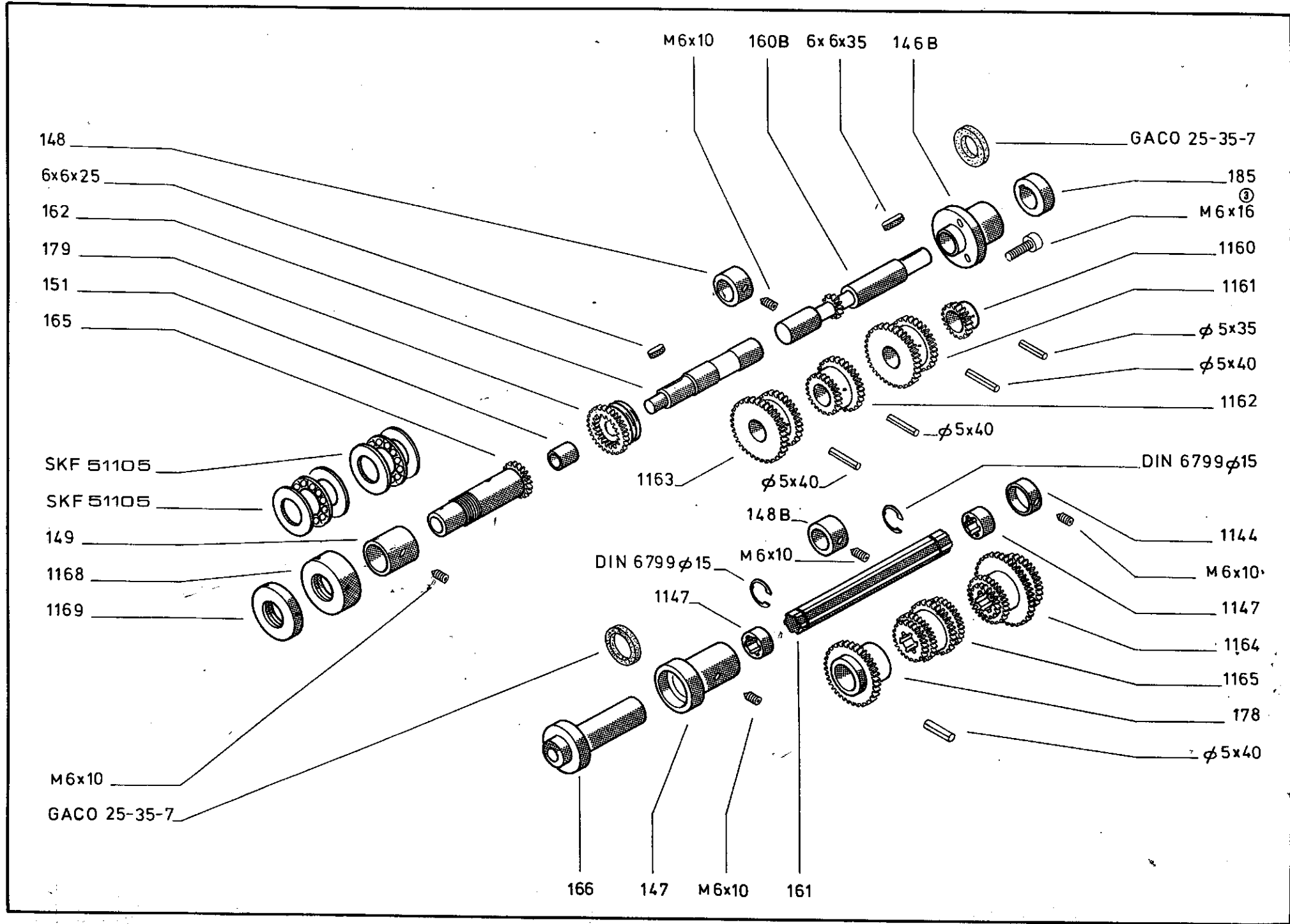

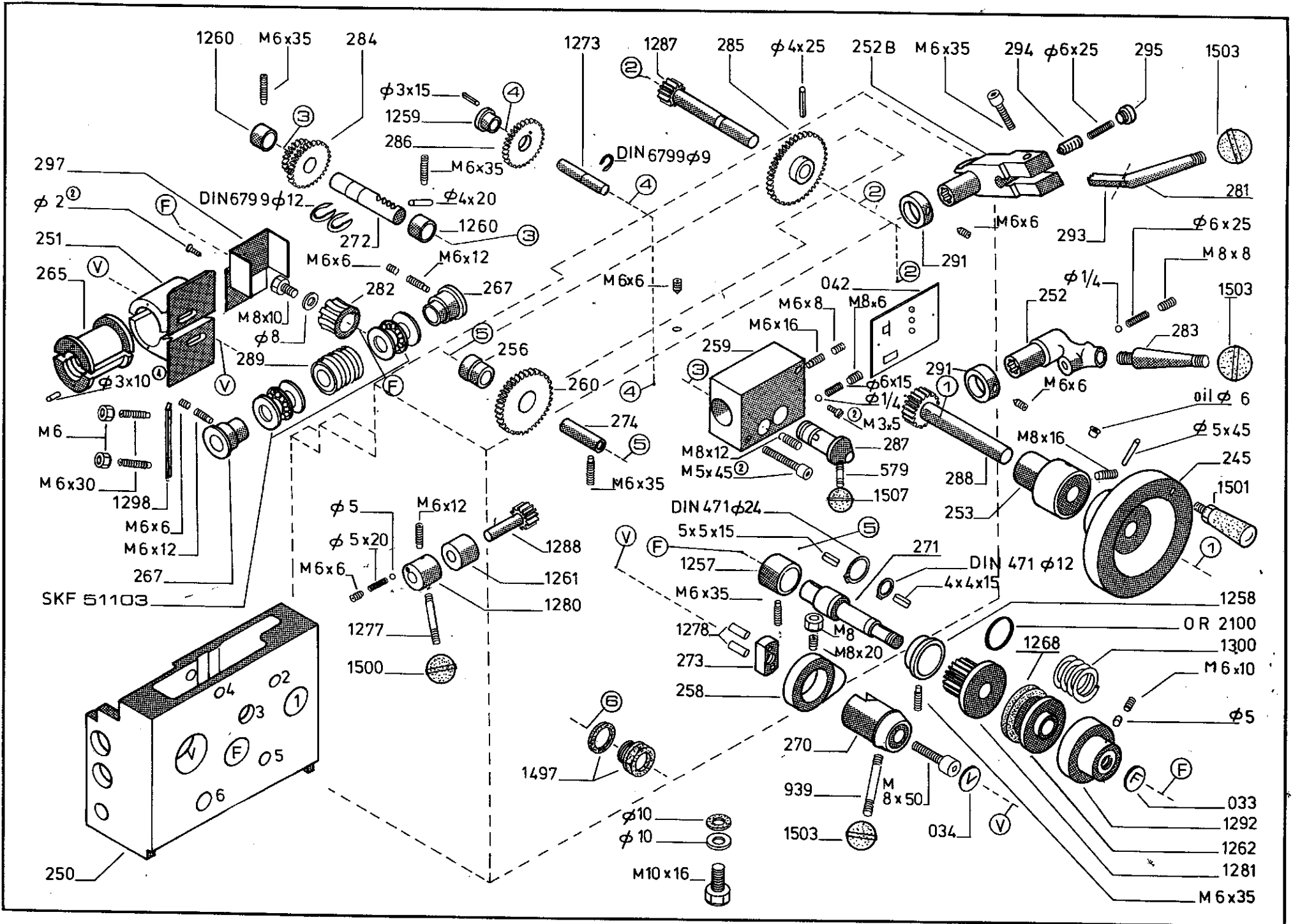

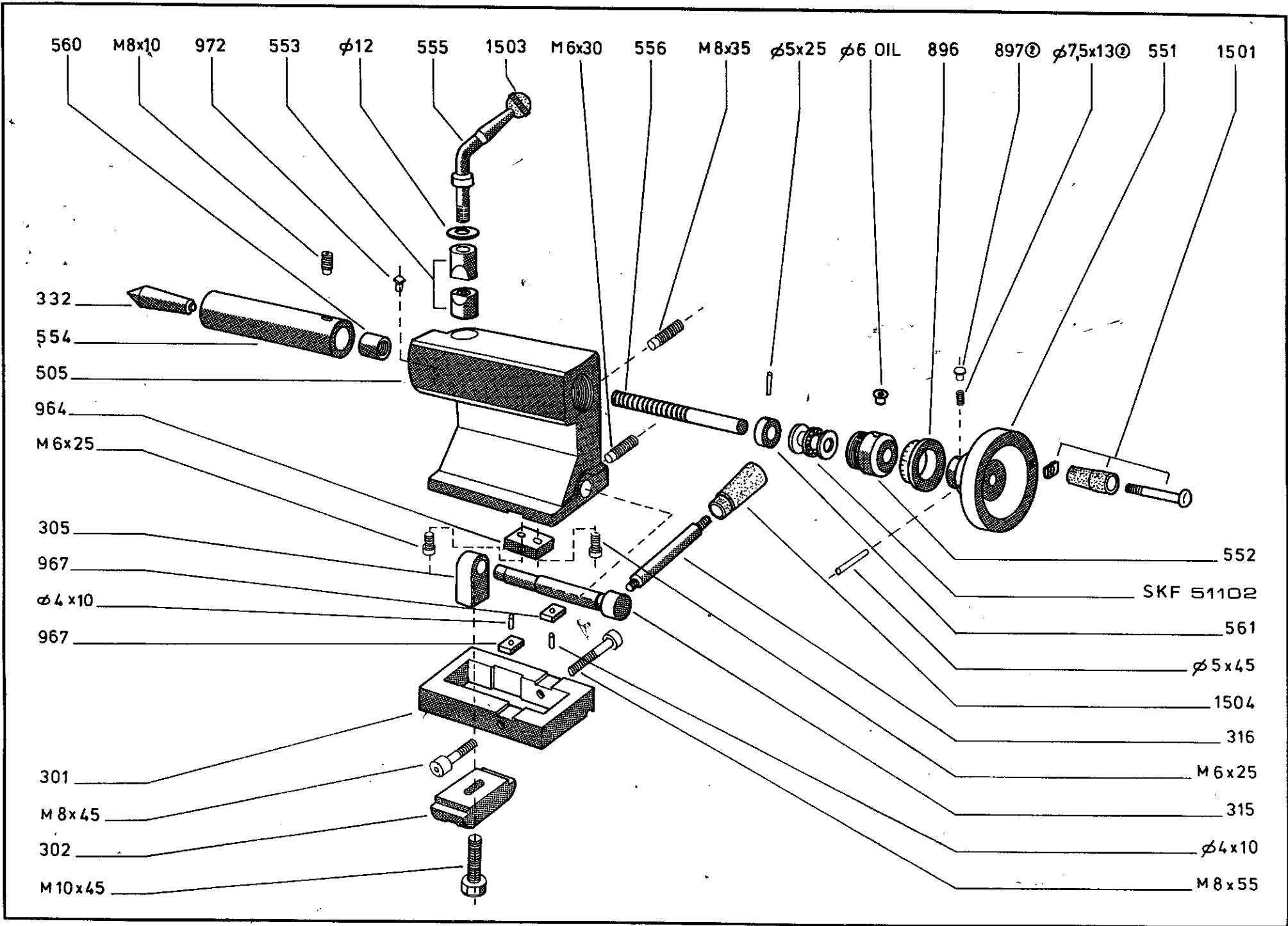

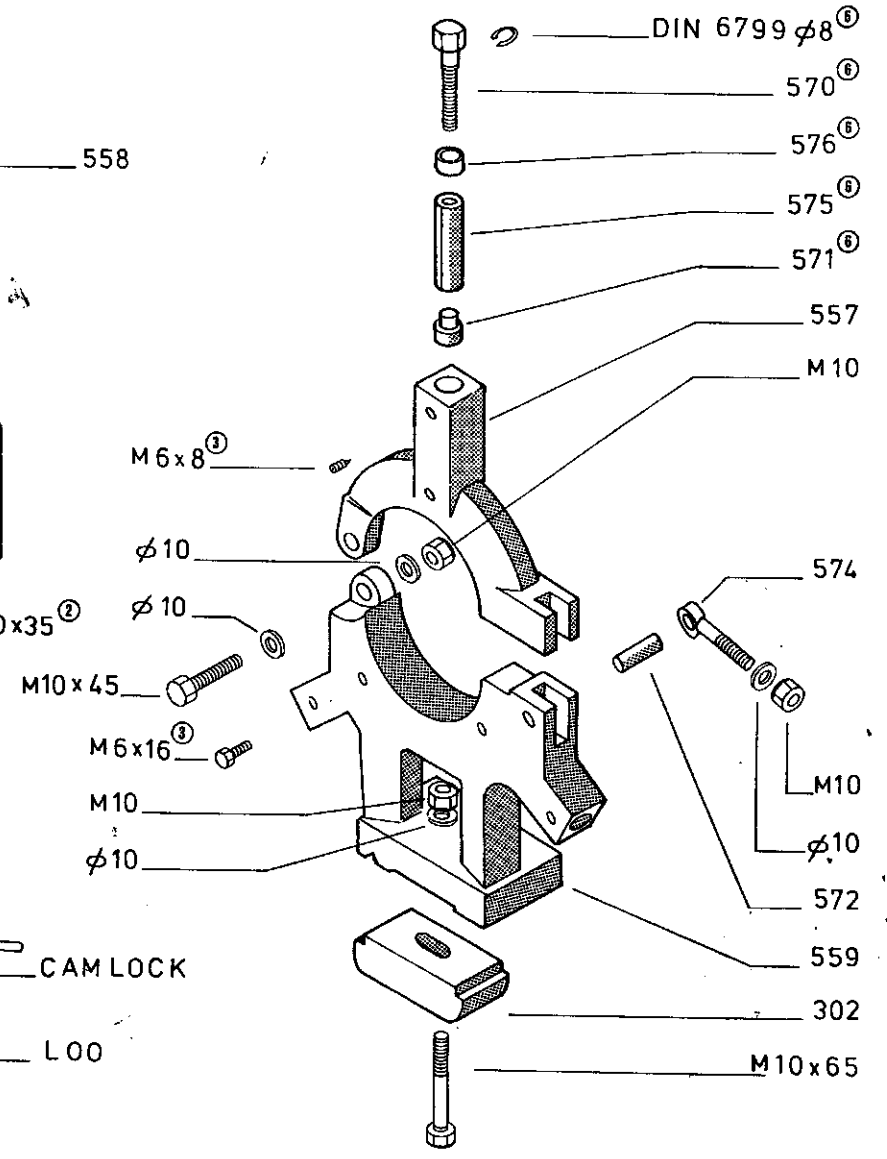
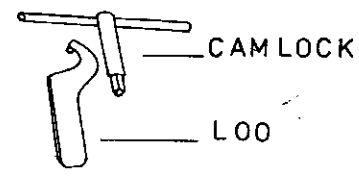
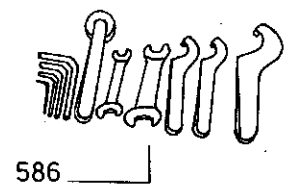
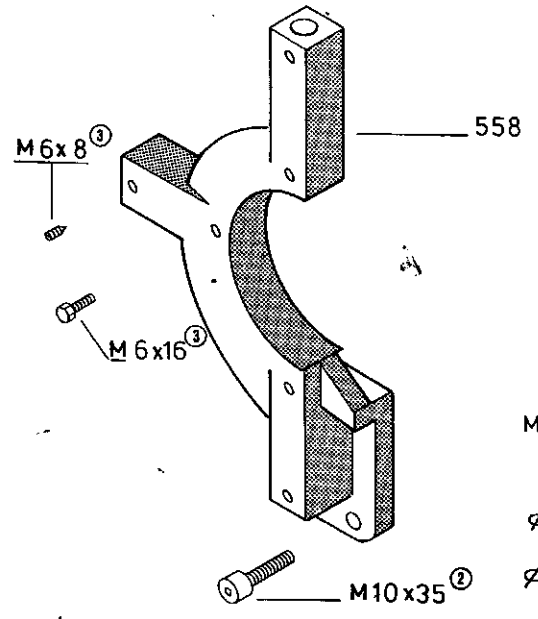
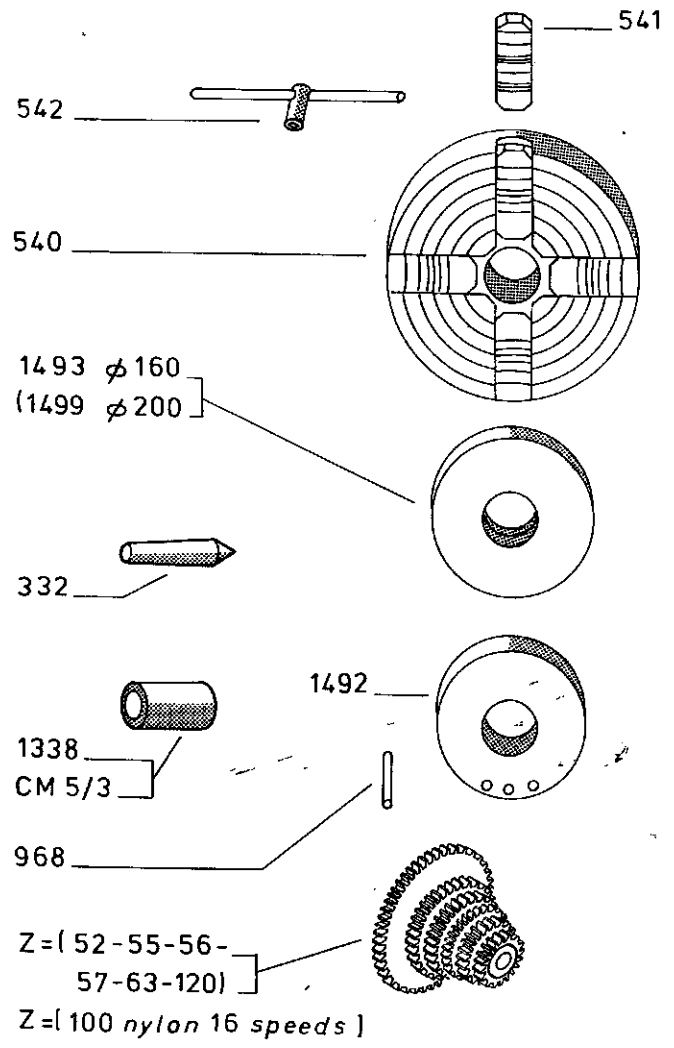

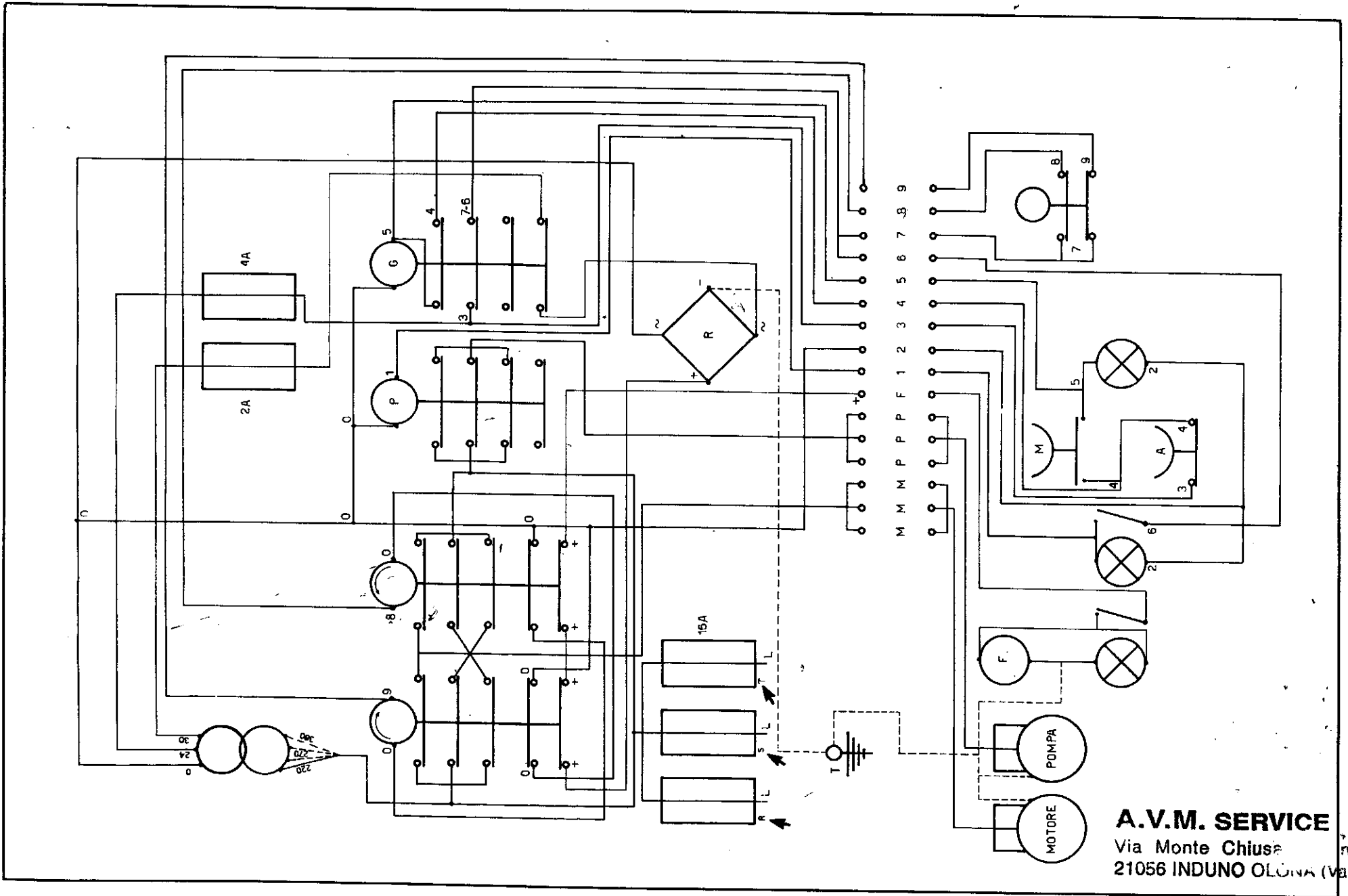

A.V.M. SERVICE
 Via Monte Chiusa n. 31
 21056 INDUNO OLGINA (Varese)

SCHEMA IMPIANTO ELETTRICO

SCHEMA DE L'INSTALLATION ELECTRIQUE

SCHEMA ELEKTRISCHE INSTALLATION

SKETCH OF ELECTRICAL EQUIPMENT

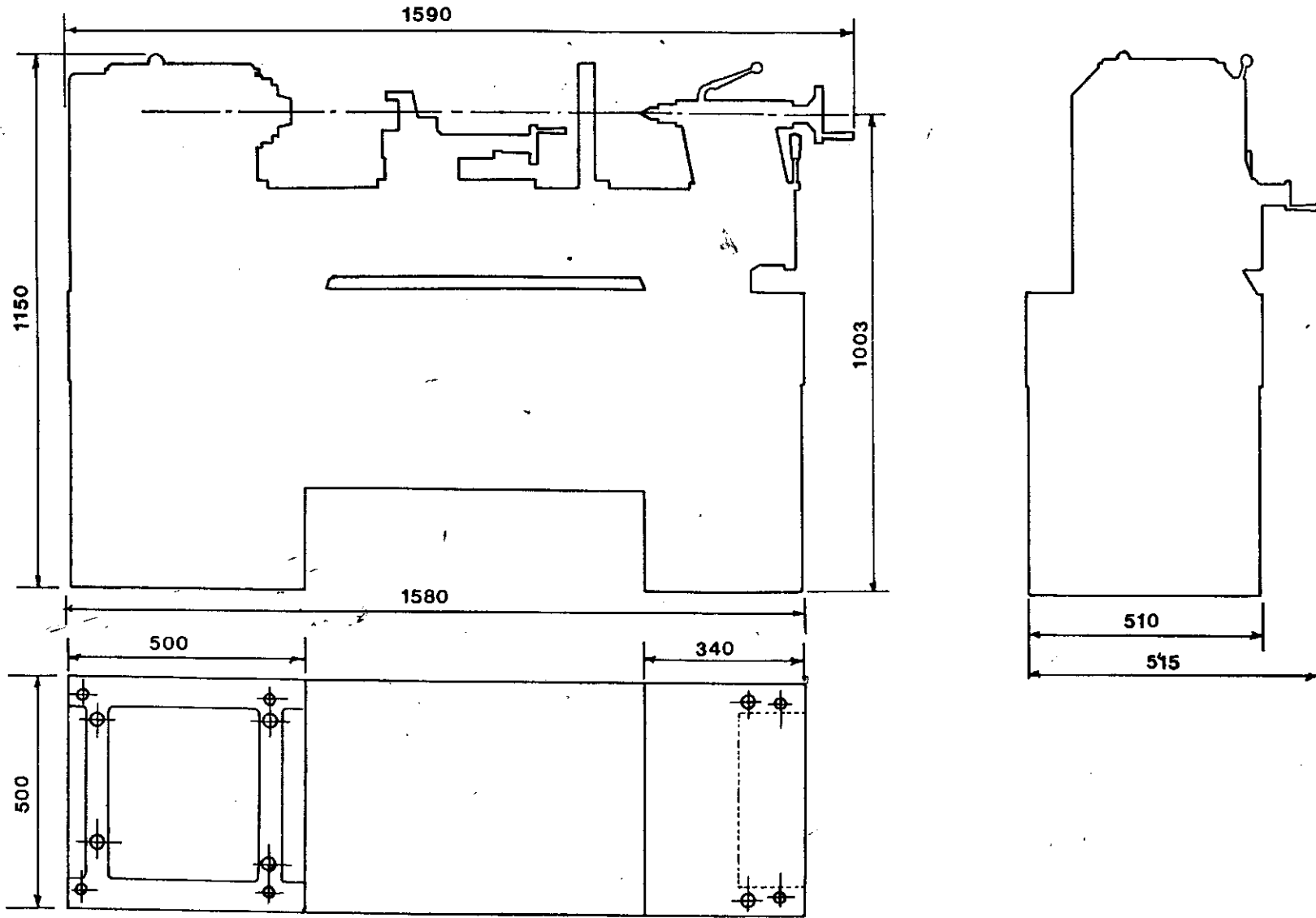

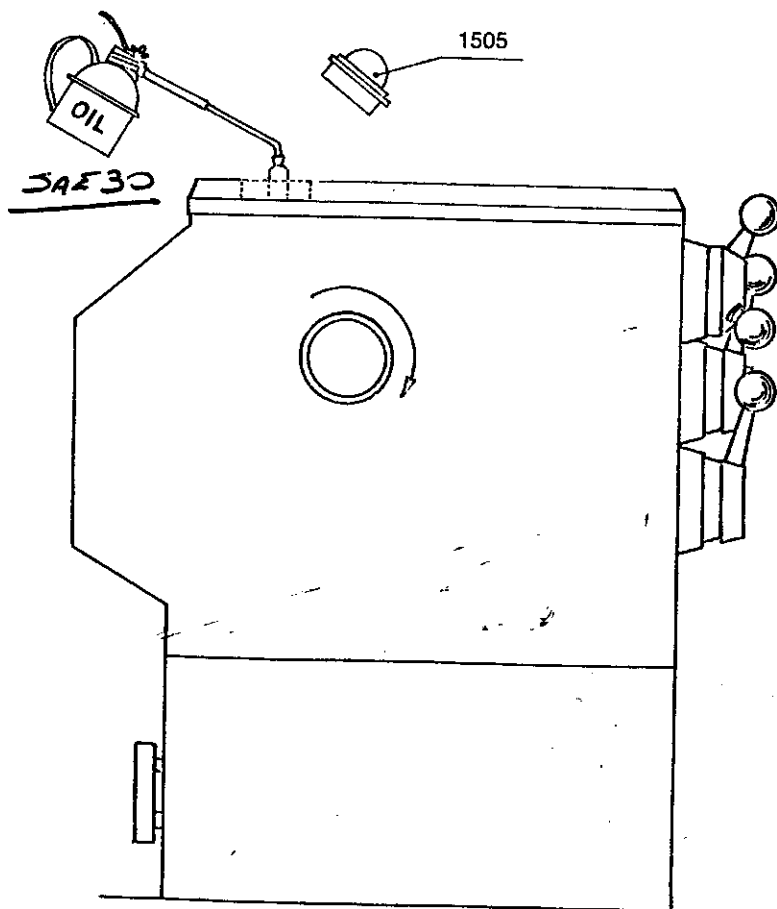

A.V.M. SERVICE

Via Monte Chiusarella, n. 31
21056 INDUNO OLONA (Varese)

Sortir pour my late --



BTST-RELAIS.

Colombo. L.

- 1 - Togliere il tappo spia n. 1505.
 - 2 - Pressare l'olio nel foro di emissione tenendo la macchina in movimento.
 - 3 - Controllare il livello sulla spia posteriore.
- 1 - Contrôler le niveau de l'huile.
 - 2 - Sortir le voyant 1505 qui est seulement coincé par un joint conique.
 - 3 - Faire fonctionner le tour et, à l'aide d'une burette, envoyer un peu d'huile par le petit trou central de la pièce fileté.
- 1 - Deckel nr. 1505 ab schrauben.
 - 2 - Das Öl in die Öffnung pressen die Maschine soll während dem laufen.
 - 3 - Den Stand des Öles Kontrollieren.



MAS 165 "S"

	1	2	3	4
	45	78	132	225
	335	570	960	1620

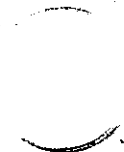
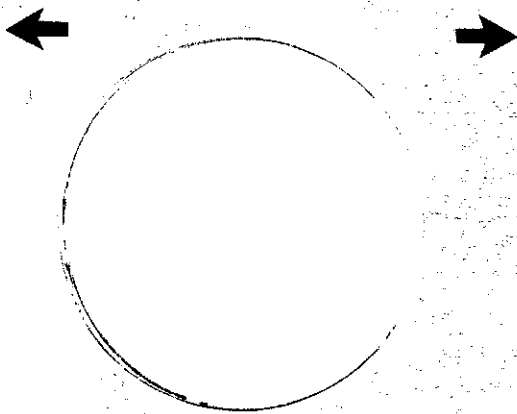
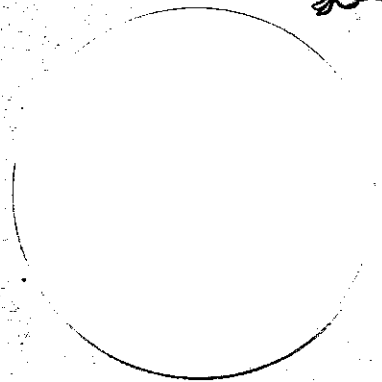
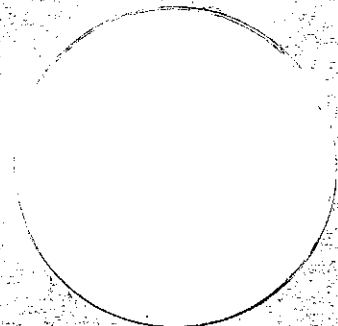

OF



OF

								WHITWORTH												
I	II	III	IV					I	II	III	IV	I	II	III	IV					
0,5	0,625	0,75	0,875	A				60	52	56	48	44	40	38	36	32	0,25	-	-	-
1	1,25	1,5	1,75	B				30	26	28	24	22	20	19	18	16	0,5	-	0,75	-
2	2,5	3	3,5	C				15	13	14	12	11	10	9,5	9	8	1	1,25	1,5	1,75
4	5	6	7	D				7½	6½	7	6	5½	5	4¾	4½	4	2	2,5	3	3,5
								Z												
				60				52	56	60	55	60	57	63	56	127-120-60 63-56-55 57-52-44 30-24				

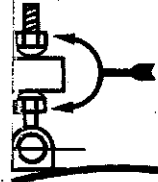

C A B

II IV III I



TIMKEN

385/383

39236/39433

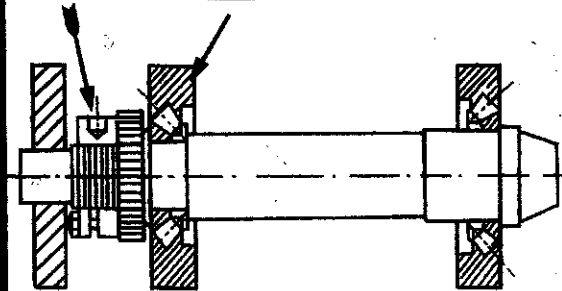

A.V.M. SERVICE
Via Monte Chiusarella, n. 31
21056 INDUNO OLONA (Varese)